

CMD

OPTISOUND 3030 C-3050 C Ultrasonic Level Gauge

for solids

- Level measurement during processing and storage of solids
- Level indication of solids in silos and hoppers
- Level measurement in stone crushes
- Profile measurement on conveyor belts



Electromagnetic flowmeters
Variable area flowmeters
Mass flowmeters
Ultrasonic flowmeters
Vortex flowmeters
Flow controllers

Level measuring instruments

Pressure and temperature
Heat metering
Communications technology
Switches, counters, displays and recorders
Engineering systems & solutions

Contents

1 Description of the measuring principle	3
2 Type overview	6
3 Mounting information	8
4 Electrical connection	
4.1 General requirements	14
4.2 Supply voltage	14
4.3 Connection cable	14
4.4 Connection of the cable screen and grounding	14
4.5 Wiring plans OPTISOUND 3030 C	15
4.6 Wiring plans OPTISOUND 3040 C and 3050 C	16
5 Adjustment	
5.1 Adjustment, general	17
5.2 Compatibility acc. to NAMUR NE 53	17
5.3 Adjustment with the indicating/adjustment module	18
6 Technical data	19
7 Dimensions	27

Take note of safety instructions for Ex application



Please note the Ex specific safety information which you will find on our homepage www.krohne-mar.com and which come with the appropriate instrument. In hazardous areas you should take note of the appropriate regulations, conformity and type approval certificates of the sensors and power supply units. The sensors must only be operated on intrinsically safe circuits. The permissible electrical values are stated in the certificate.

1 Description of the measuring principle



Measuring principle

Short ultrasonic pulses in the range of 18 kHz to 35 kHz are emitted by the transducer to the product surface, reflected there and received by the transducer. The pulses travel at the speed of sound - the elapsed time from emission to reception of the signals depends on the level in the vessel.

The latest microcomputer technology and the proven processing software select the level echo from among any number of false echoes and calculate the exact distance to the product surface. An integrated temperature sensor detects the temperature in the vessel and compensates the influence of temperature on the signal running time.

By simply entering the vessel dimensions, a level-proportional signal is generated from the distance. It is not necessary to fill the vessel for adjustment.

Wide application range

OPTISOUND 3030 C, 3040 C and 3050 C ultrasonic sensors are especially suitable for level measurement of solids, but are also good for liquids. The instruments differ in the measuring range, the transducer version and the process fitting. Through different, adapted emitting frequencies and efficient transducers, levels in a measuring range of 15 ... 45 m (49.2 ... 147.6 ft) can be measured. Resistant materials for the transducers and process fittings also allow applications in corrosive products (depending on the model).

A version suitable for each application

Adaptable sensors are a must for the wide variety of product characteristics and installation conditions. OPTISOUND ultrasonic sensors meet this requirement with versions suitable for all applications.

A practical mounting strap (option) enables flexible orientation of OPTISOUND 3030 C.

Four different versions of OPTISOUND 3040 C and 3050 C enable installation in virtually all vessels and optimum orientation to the product cone:

- Version A compact in flange version
- Version B compact with swivelling holder
- Version C separate with swivelling holder
- Version D separate with thread fitting.

Unaffected by product properties

Fluctuations in product composition or even complete product changes do not influence the measuring result. A fresh adjustment is not necessary.

Service and maintenance friendly

Thanks to the non-contact measuring principle, OPTISOUND sensors are particularly easy to service and maintain.

1.1 Application examples

Conveyor belt with sugar beets

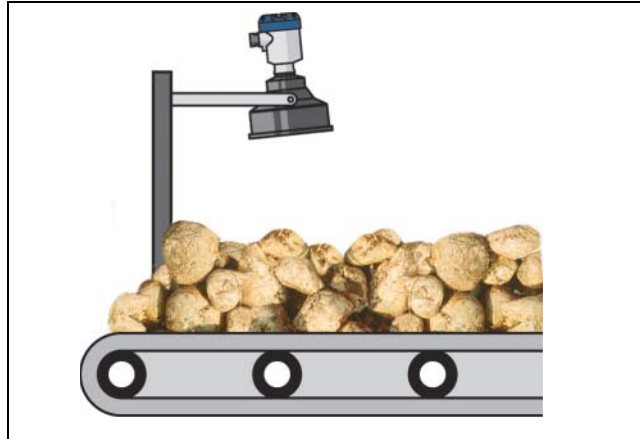

Fig. 1: Profile measurement on a conveyor belt with OPTISOUND 3030 C

The sugar beets used for sugar production are poured from trucks onto conveyor belts on which they are transported for further processing. OPTISOUND sensors are an economic solution for profile monitoring. Ultrasonic waves are reflected by the medium, the integrated electronics detects the charging height of the conveyor belt. By means of the mounting strap, OPTISOUND 3030 C can be optimally oriented to the medium. Thanks to its high emitting power, fog, wind and moisture do not affect measurement reliability.

Plastic granules

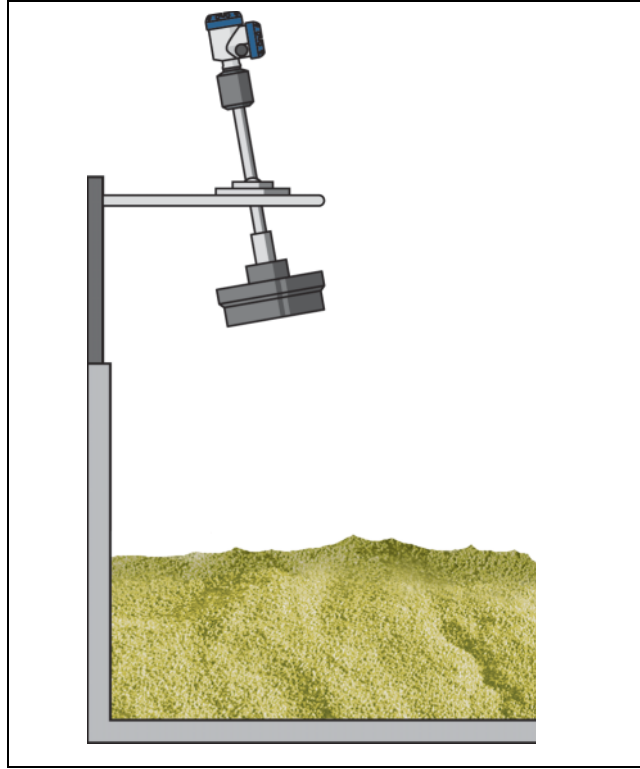

Fig. 2: Level measurement in a plastic granules silo with OPTISOUND 3040 C

Plastic granules are often stored in high, narrow silos that are filled pneumatically. OPTISOUND ultrasonic sensors are particularly suitable for level measurement of plastic granules. They are equipped with powerful transducers and optimised signal processing. A swivelling holder on the mounting flange ensures optimum orientation to the product, also when material cones form.

2 Type overview

OPTISOUND 3030 C



OPTISOUND 3040 C



Preferred application:	liquids and solids	Solids
Measuring range:	liquids: 0.6 ... 15 m (2 ... 49.2 ft) solids: 0.6 ... 7 m (2 ... 23 ft)	liquids: 1 ... 25 m (3.3 ... 82 ft) solids: 1 ... 15 m (3.3 ... 49.2 ft)
Process fitting:	compression flange DN 100 or mounting strap	flange DN 200, with swivelling holder from DN 50
Process temperature:	-40 ... +80°C (-40 ... +176°F)	-40 ... +80°C (-40 ... +176°F)
Process pressure:	-20 ... 100 kPa (-0.2 ... 1.0 bar/-2.9 ... 14.5 psi)	-20 ... 150 kPa (-0.2 ... 1.5 bar/-2.9 ... 21.8 psi)
Signal output	two-wire/four-wire 4 ... 20 mA/HART	four-wire 4 ... 20 mA/HART

OPTISOUND 3050 C



Preferred application:	Solids
Measuring range:	liquids: 0.8 ... 45 m (2.6 ... 147.6 ft) solids: 0.8 ... 25 m (2.6 ... 82 ft)
Process fitting:	flange DN 250, with swivelling holder from DN 50
Process temperature:	-40 ... +80°C (-40 ... +176°F)
Process pressure:	-20 ... 150 kPa (-0.2 ... 1.5 bar/-2.9 ... 21.8 psi)
Signal output	four-wire 4 ... 20 mA/HART

Indicating and adjustment module

Housing

Plastic



Stainless steel



Aluminium

Aluminium
(double chamber)

Electronics
4 ... 20 mA/
HART four-wire

Sensors
Transducer
15 mTransducer
25 mTransducer
45 m

Approvals
Dust explosion
protection

3 Mounting information

Measuring range

The reference plane for the measurement depends on the version. For the OPTISOUND 3040 C and 3050 C in flange version (version A) the lower edge of the flange is the reference plane. For the versions with swivelling holder (versions B and C), with threaded fitting (version D) as well as for OPTISOUND 3030 C, the lower edge of the transducer is the reference plane. All statements concerning the measuring range as well as the internal signal relate to this plane.

With all instruments, a min. distance from the lower edge of the flange - the so-called dead zone, in which measurement is not possible - must be maintained. The exact value of the dead zone, depending on the instrument version, is stated in the Technical data.

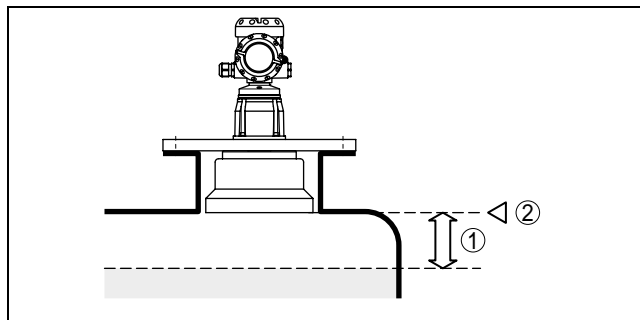

Fig. 3: Min. distance to the max. level on the example of an OPTISOUND 3030 C

- 1 Dead zone
- 2 Reference plane for the measurement



Note:

If the product reaches the transducer, buildup can form on it over a period of time and later cause measurement errors.

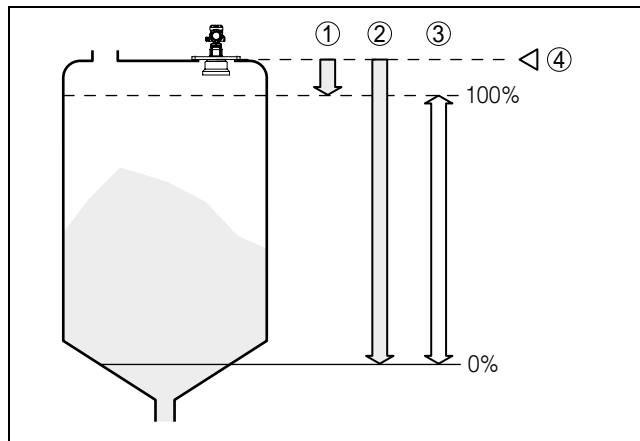

Fig. 4: OPTISOUND 3040 C and 3050 version A – Measuring range (operating range) and max. measuring distance

- 1 full (dead zone)
- 2 empty (max. measuring distance)
- 3 Measuring range
- 4 Reference plane

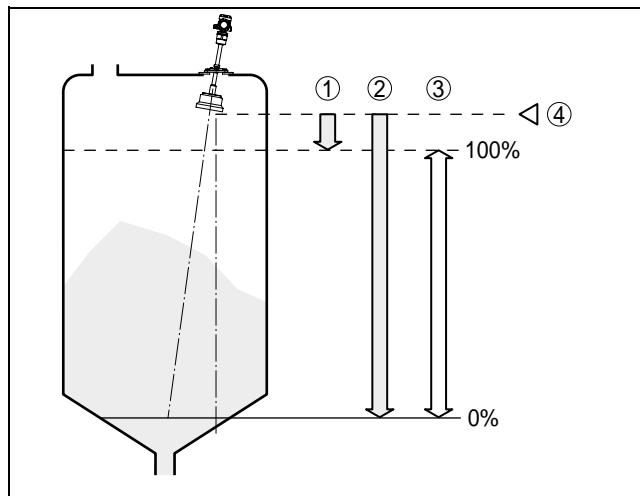

Fig. 5: OPTISOUND 3030 C ... 3050 C version B, C, D – Measuring range (operating range) and max. measuring distance

- 1 full (dead zone)
- 2 empty (max. measuring distance)
- 3 Measuring range
- 4 Reference plane

Pressure/Vacuum

Gauge pressure in the vessel does not influence OPTISOUND. Low pressure or vacuum, however damp the ultrasonic pulses. This influences the measuring result, particularly if the level is very low. With pressures under -0,2 bar (-20 kPa) use a different measuring principle, e.g. radar or guided radar (TDR).

Installation position

The mounting position of OPTISOUND 3030 C must be at least 200 mm (OPTISOUND 3040 C and 3050 C - at least 500 mm) from the vessel wall. If the sensor is installed in the center of dished or spherical vessel tops, multiple echoes can result. These can be faded out, however, through an appropriate adjustment.

If you cannot keep this distance, a false echo storage should be carried out during setup. This applies particularly if buildup on the vessel wall is expected. In this case, we recommend repeating the false echo storage later on with existing buildup.

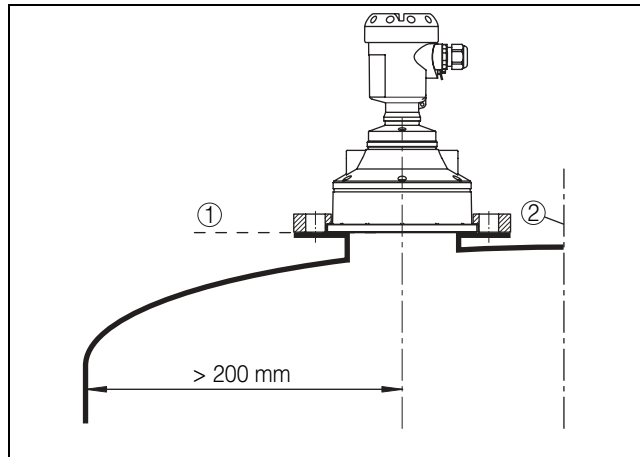

Fig. 6: Mounting of OPTISOUND 3030 C on round vessel tops

- 1 Reference plane
- 2 Vessel center or symmetry axis

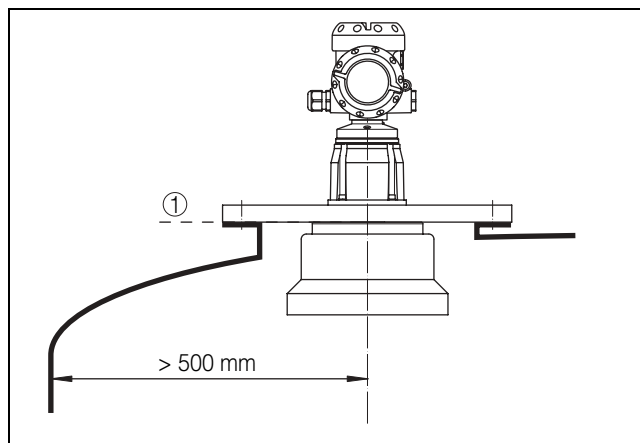

Fig. 7: Mounting of OPTISOUND 3040 C and 3050 C on round vessel tops

- 1 Reference plane

In vessels with conical bottom it can be advantageous to mount the sensor in the center of the vessel, as measurement is then possible down to the lowest point of the vessel bottom.

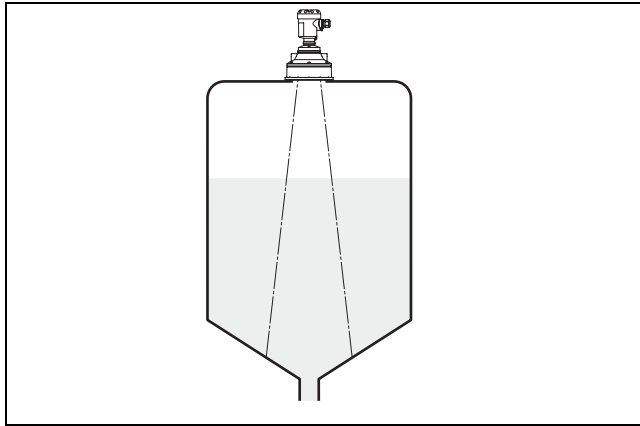

Fig. 8: OPTISOUND 3030 C on a vessel with conical bottom – Medium liquid

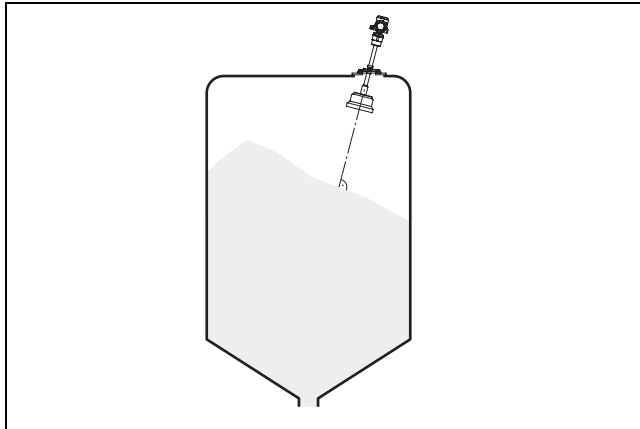

Fig. 9: OPTISOUND 3040 C on a vessel with conical bottom – Medium solid

Socket

The transducer should be mounted preferably without socket, flush with the vessel top.

If the reflective properties of the medium are good, you can mount OPTISOUND on a socket piece higher than the transducer length. The socket end should be smooth and burr-free, if possible, also rounded. A false echo storage is recommended.

Sensor orientation

With liquids, align the sensor as close to vertical as possible to achieve optimum measuring results.

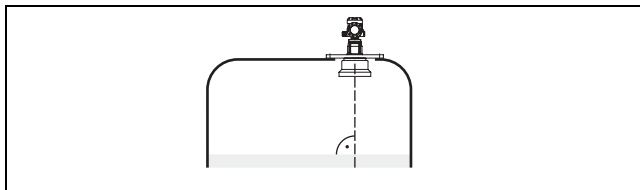

Fig. 10: Orientation in liquids

The version with swivelling holder is recommended for optimum orientation to solids.

Vessel installations

The ultrasonic sensor should be installed at a location where no installations cross the ultrasonic beam.

Vessel installations such as, for example, ladders, limit switches, heating spirals, struts, etc. can cause false echoes superimposed on the wanted echo. Make sure when planning your measuring location that the ultrasonic signals have "free access" to the measured product.

If there are existing vessel installations, a false echo storage should be carried out during setup.

If large vessel installations such as struts or supports cause false echoes, these can be attenuated through supplementary measures. Small, inclined sheet metal or plastic baffles above the installations scatter the ultrasonic signals and avoid direct false echoes.

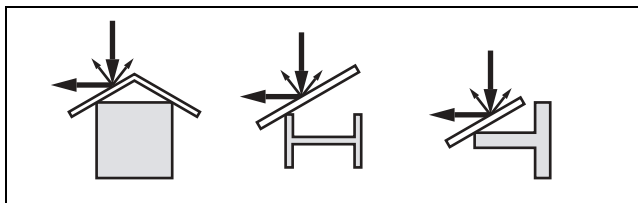

Fig. 11: Cover smooth profiles with deflectors

Material heaps

Large material heaps are detected with several sensors, which can be mounted on e. g. traverse cranes. For this type of application, it is best to direct the sensor perpendicularly to the solid surface.

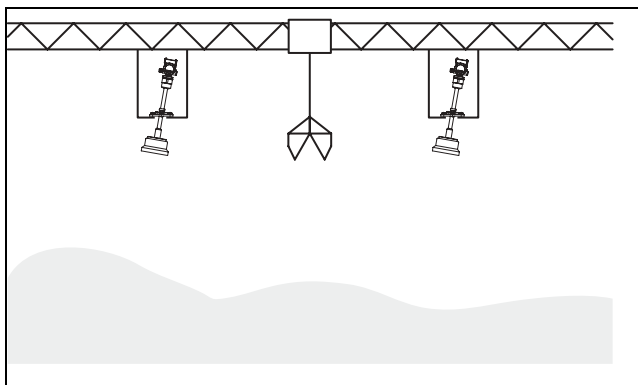

Fig. 12: Transducers on traverse crane

Inflowing material

The instruments must not be mounted in or above the filling stream. Make sure that the product surface and not the inflowing material is detected.

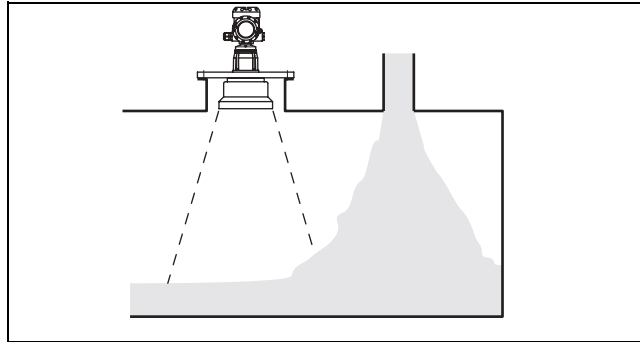

Fig. 13: Inflowing liquid

Foam

Through the action of filling, stirring and other processes in the vessel, dense foams which considerably damp the emitted signals may form on the product surface.

If foams are causing measurement errors, the sensor should be used in a standpipe or, alternatively, the more suitable sensors with guided radar (TDR) should be used.

Guided radar is not influenced by foam generation and is particularly suitable for such applications.

Air flow

If there are strong air currents in the vessel, e.g. due to strong winds in outdoor installations, or because of air turbulence, you should mount OPTISOUND in a standpipe or use a different measuring principle, e.g. radar or guided radar (TDR).

Heat fluctuations

Strong heat fluctuations, e.g. caused by the sun, can cause measurement errors. In this case, you should use a sun shield.

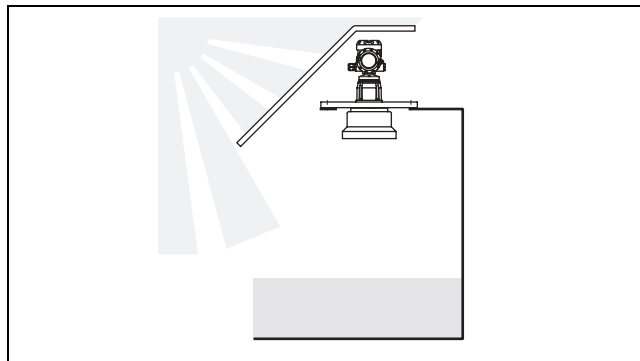

Fig. 14: Protection against the sun

4 Electrical connection

4.1 General requirements

The power supply range can differ depending on the instrument version. The exact range is stated in the Technical data.

Take note of country-specific installation standards (e.g. the VDE regulations in Germany) as well as prevailing safety regulations and accident prevention rules.



In hazardous areas you should take note of the appropriate regulations, conformity and type approval certificates of the sensors and power supply units.

4.2 Supply voltage

4 ... 20 mA/HART two-wire

Power supply and current signal are carried over the same two-wire connection cable. The requirements on the power supply are stated in the Technical data of this Product Information manual.

4 ... 20 mA/HART four-wire

Power supply and current output are carried on two separate connection cables.

The standard version can be operated with an earth-connected current output, the Exd version must be operated with a floating output.

The instrument is designed in protection class I. To maintain this protection class, it is absolutely necessary that the ground conductor be connected to the internal ground conductor terminal.

4.3 Connection cable

The sensors are connected with standard cable without screen. An outer cable diameter of 5 ... 9 mm ensures the seal effect of the cable entry.

If strong electromagnetic interference is expected, screened cable should be used for the signal lines.



In Ex applications, the corresponding installation regulations must be noted for the connection cable.

4.4 Connection of the cable screen and grounding

If screened cable is required, the cable screen must be connected on both ends to ground potential. If potential equalisation currents are expected, the connection on the evaluation side must be made via a ceramic capacitor (e.g. 1 nF, 1500 V).

4.5 Wiring plans OPTISOUND 3030 C

Single chamber housing

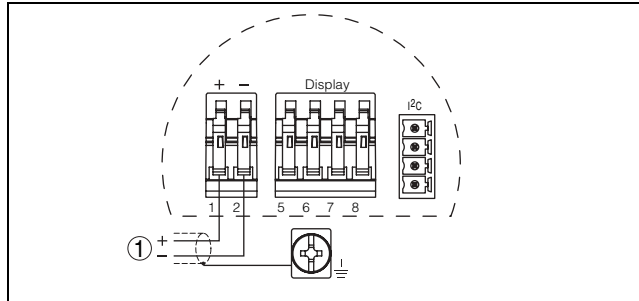

Fig. 15: Connection HART two-wire, Profibus PA, Foundation Fieldbus

1 Power supply and signal output

Double chamber housing – two-wire

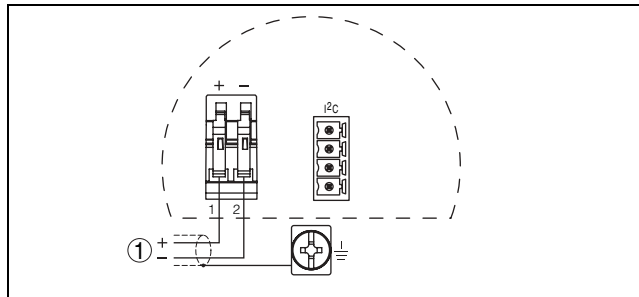

Fig. 16: Connection HART two-wire, Profibus PA, Foundation Fieldbus

1 Power supply and signal output

Double chamber housing – 4 ... 20 mA/HART four-wire

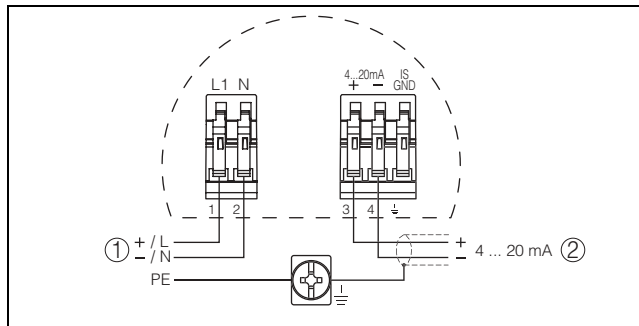

Fig. 17: Connection 4 ... 20 mA/HART four-wire

1 Supply voltage
2 Signal output

4.6 Wiring plans OPTISOUND 3040 C and 3050 C

Double chamber housing – 4 ... 20 mA/HART four-wire

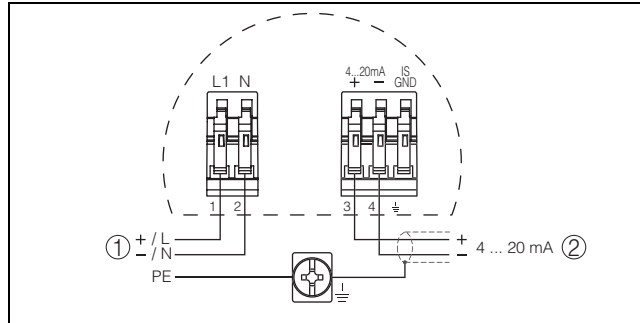

Fig. 18: Connection 4 ... 20 mA/HART four-wire

- 1 Supply voltage
- 2 Signal output

5 Adjustment

5.1 Adjustment, general

OPTISOUND can be adjusted with the following adjustment media:

- the indicating and adjustment module
- a HART handheld (4 ... 20 mA/HART)

The entered parameters are generally saved in OPTISOUND, optionally also in the indicating/adjustment module.

5.2 Compatibility acc. to NAMUR NE 53

OPTISOUND meet NAMUR recommendation NE 53.

The parameter adjustment of the basic sensor functions is independent of the software version. The range of available functions depends on the respective software version of the individual components.

5.3 Adjustment with the indicating/adjustment module

Setup and indication

The indication and adjustment module can be plugged into OPTISOUND sensors. It can be placed in four different positions on the instrument (each displaced by 90°). Indication and adjustment are made via four keys and a clear, graphic-capable dot matrix indication. The adjustment menu with language selection is clearly structured and enables easy setup. After setup, the indicating/adjustment module serves as indicating instrument: through the screwed cover with glass insert, measured values can be read directly in the requested unit and presentation.

Adjustment

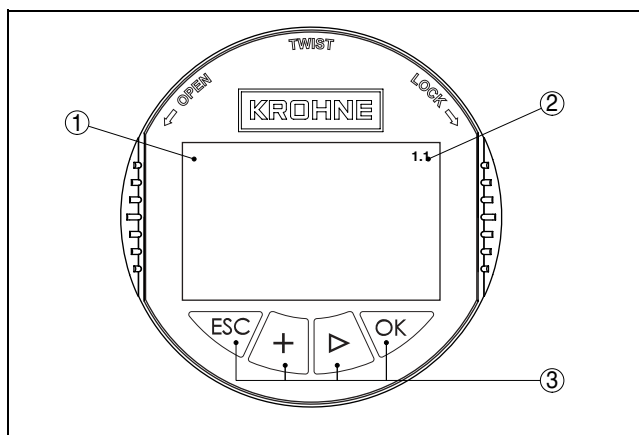

Fig. 19: Indicating and adjustment elements

- 1 LC display
- 2 Indication of the menu item number
- 3 Adjustment keys

Key functions

- **[OK]** key:
 - move to the menu overview
 - confirm selected menu
 - edit parameter
 - save value
- **[→]** key to select:
 - menu change
 - list entry
 - editing position
- **[+]** key:
 - modify value of a parameter
- **[ESC]** key:
 - interrupt input
 - jump to the next higher menu

6 Technical data

General data

OPTISOUND 3030 C

Materials, wetted parts	
– Mounting strap	1.4301
– Process fitting	UP
– transducer diaphragm	316Ti (1.4571)
– Seal transducer/process fitting	EPDM
Materials, non-wetted parts	
– Compression flange	PPH, 316L (1.4435)
– Housing	plastic PBT (Polyester), Alu-die casting powder-coated, 1.4435
– Seal ring between housing and housing cover	NBR (stainless steel housing), silicone (Alu/plastic housing)
– Inspection window in housing cover for indicating/adjustment module	Polycarbonate (UL746-C listed)
– Ground terminal	316Ti/316L (1.4571/1.4435)
Weight ¹⁾	2.7 ... 5.7 kg (6 ... 12.6 lbs)

OPTISOUND 3040 C and 3050 C

Materials, wetted parts	
– Flange	PP or Alu
– swivelling holder, threaded fitting	galvanized steel
– Transducer OPTISOUND 3040 C	PA (1.4301 with StEx)
– Transducer OPTISOUND 3040 C and 3050 C	UP
– Transducer diaphragm OPTISOUND 3040 C	316Ti (1.4571)
– Transducer diaphragm OPTISOUND 3050 C	Alu/PE foam rubber coating
Materials, non-wetted parts	
– Housing	Alu die-casting powder-coated
– Seal ring between housing and housing cover	silicone
– Inspection window in housing cover for indicating/adjustment module	Polycarbonate (UL746-C listed)
– Ground terminal	316Ti/316L (1.4571/1.4435)
– Transducer cable OPTISOUND 3040 C and 3050 C	PUR (1.1082)
Weight ²⁾ OPTISOUND 3040 C	
– Version A	5.6 ... 10.7 kg (12.3 ... 23.6 lbs)
– Version B	6.9 ... 9.7 kg (15.2 ... 21.4 lbs)
– Version C	7.5 ... 10.5 kg (16.5 ... 23.1 lbs)
– Version D	4.7 ... 6.9 kg (10.4 ... 15.2 lbs)
Weight ³⁾ OPTISOUND 3050 C	
– Version A	8.0 ... 13.3 kg (17.6 ... 29.3 lbs)
– Version B	8.7 ... 10.3 kg (19.2 ... 22.7 lbs)
– Version C	9.2 ... 11.1 kg (20.3 ... 24.5 lbs)
– Version D	6.5 ... 7.5 kg (14.3 ... 16.5 lbs)

1) Depending on the process fitting and housing.
 2) Depending on process fitting.
 3) Depending on process fitting.

Output variable

Output signal	4 ... 20 mA/HART
Resolution	1.6 μ A
Fault signal	current output unchanged; 20.5 mA; 22 mA; <3.6 mA (adjustable)
Current limitation	22 mA
Load	see load diagram in Power supply
Integration time (63 % of the input variable)	0 ... 999 s, adjustable
Rise time	500 ms (ti: 0 s, 0 ... 100 %)
Fulfilled NAMUR recommendation	NE 43
Integration time (63 % of the input variable)	0 ... 999 s, adjustable
Rise time	500 ms (ti: 0 s, 0 ... 100 %)

Input variable

Parameter	distance between lower edge of the transducer and product surface
Dead zone	
– OPTISOUND 3030 C	0.6 m (2 ft)
– OPTISOUND 3040 C	1 m (3.3 ft)
– OPTISOUND 3050 C	0.8 m (2.6 ft)
Measuring range	
– OPTISOUND 3030 C	up to 15 m (49.2 ft) liquid/up to 7 m (23 ft) solid
– OPTISOUND 3040 C	up to 25 m (82 ft) liquid/up to 15 m (49.2 ft) solid
– OPTISOUND 3050 C	up to 45 m (147.6 ft) liquid/up to 25 m (82 ft) solid

Accuracy (similar to DIN EN 60770-1)

Reference conditions acc. to DIN EN 61298-1	
– Temperature	18 ... 30°C (64 ... 86°F)
– Relative humidity	45 ... 75 %
– Atmospheric pressure	860 ... 1060 mbar (86 ... 106 kPa/ 12.5 ... 15.4 psi)

Characteristic curve deviation and measurement characteristics⁴⁾

Average temperature coefficient of the zero signal (temperature error)	0.06 %/10 K
Resolution, general	max. 1 mm

⁴⁾ Relating to the nominal range, incl. hysteresis and repeatability, determined acc. to the limit point method.

Ultrasonic frequency/Beam angle

- OPTISOUND 3030 C 35 kHz/5.5°
- OPTISOUND 3040 C 30 kHz/4°
- OPTISOUND 3050 C 18 kHz/5°

Interval >2 s (dependent on the parameter adjustment)

Adjustment time⁵⁾ >3 s (dependent on the parameter adjustment)

Accuracy better than 0.2 % or ±6 mm (see respective diagram)

OPTISOUND 3030 C

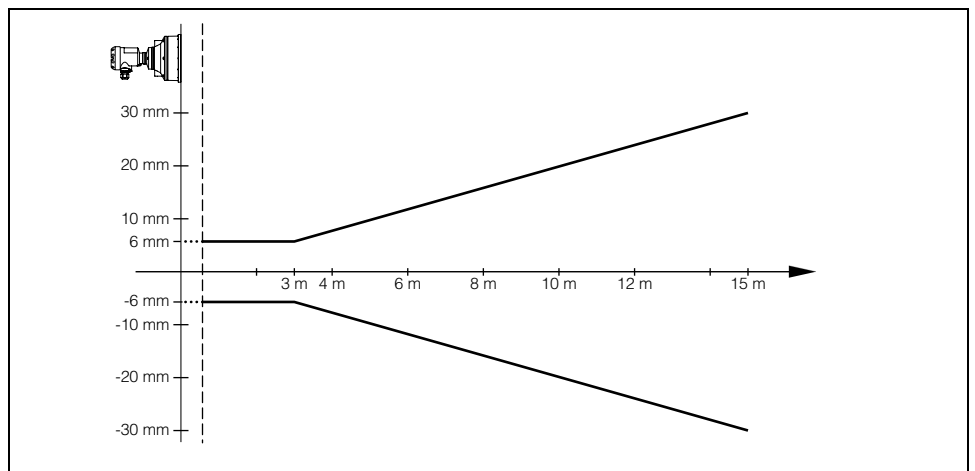

Fig. 20: Accuracy diagram OPTISOUND 3030 C

OPTISOUND 3040 C

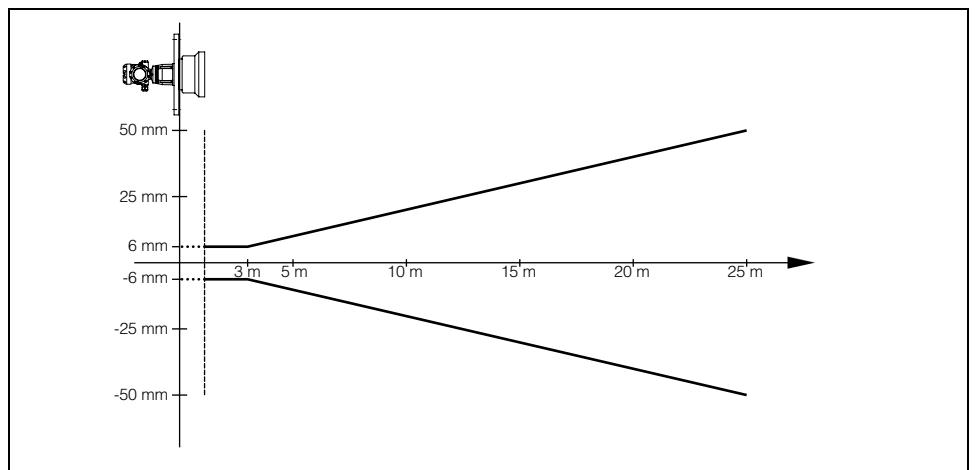

Fig. 21: Accuracy diagram OPTISOUND 3040 C – Version A

⁵⁾ Time to output the correct level (with max. 10 % deviation) after a sudden level change.

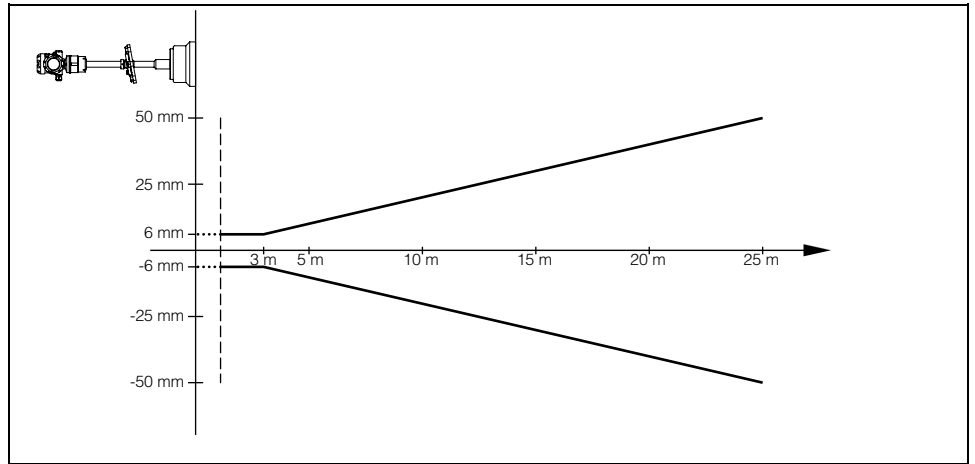

Fig. 22: Accuracy diagram OPTISOUND 3040 C – Versions B, C, D

OPTISOUND 3050 C

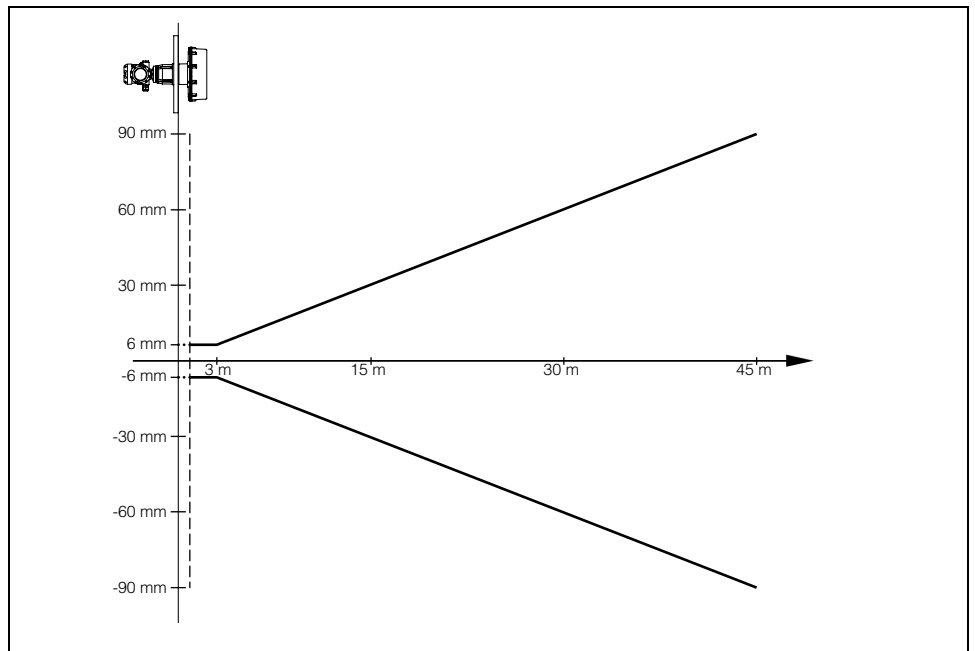

Fig. 23: Accuracy diagram OPTISOUND 3050 C – Version A

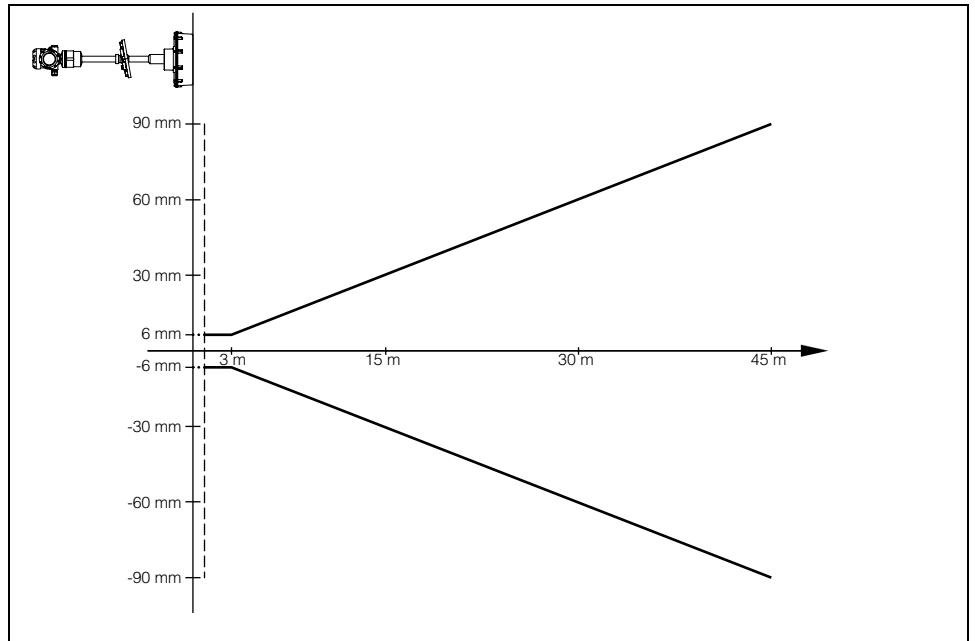

Fig. 24: Accuracy diagram OPTISOUND 3050 C – Versions B, C, D

Ambient conditions

Ambient, storage and transport temperature

- without indicating and adjustment module -40 ... +80°C (-40 ... +176°F)
- the indicating and adjustment module -20 ... +70°C (-4 ... +158°F)

Process conditions

Vessel pressure

- Input variable OPTISOUND 3030 C with compression flange -20 ... 100 kPa (-0.2 ... 1 bar/-2.9 ... 14.5 psi)
- OPTISOUND 3030 C with mounting strap 0 kPa (0 bar/0 psi), because no sealing possibility
- OPTISOUND 3040 C and 3050 C -20 ... 50 kPa (-0.2 ... 0.5 bar/-2.9 ... 7.3 psi)
- OPTISOUND 3040 C and 3050 C – Version A with PP flange 0 kPa (0 bar/0 psi)

Process temperature (transducer temperature) -40 ... +80°C (-40 ... +176°F)

Vibration resistance mechanical vibrations with 4 g and 5 ... 100 Hz⁶⁾

⁶⁾ Tested acc. to the regulations of German Lloyd, GL directive 2

Electromechanical data

Cable entry

– Single chamber housing

- 1x cable entry M20x1.5 (cable- \emptyset 5 ... 9 mm), 1x blind stopper M20x1.5

or:

- 1x closing cap $\frac{1}{2}$ NPT, 1x blind stopper $\frac{1}{2}$ NPT

– Double chamber housing

- 1x cable entry M20x1.5 (cable- \emptyset 5 ... 9 mm), 1x blind stopper M20x1.5

or:

- 1x closing cap $\frac{1}{2}$ NPT, 1x blind stopper $\frac{1}{2}$ NPT

Spring-loaded terminals

for wire cross sections up to 2.5 mm²

Indicating and adjustment module

Power supply and data transmission	through sensor via gold-plated sliding contacts (I ² C bus)
Indication	LC display in full dot matrix
Adjustment elements	4 keys
Protection	
– unassembled	IP 20
– mounted into the sensor without cover	IP 40
Materials	
– Housing	ABS
– Inspection window	Polyester foil

Supply voltage

Power supply – two-wire instrument	
– non-Ex instrument	14 ... 36 V DC
– EEx ia instrument	14 ... 30 V DC
Permissible residual ripple	
– < 100 Hz	U _{ss} < 1 V
– 100 Hz ... 10 kHz	U _{ss} < 10 mV
Load	see diagram

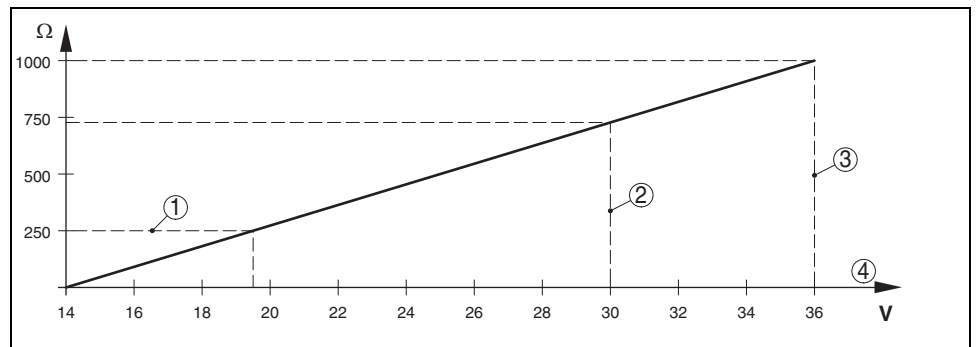

Fig. 25: Voltage diagram

- 1 HART load
- 2 Voltage limit EEx ia instrument
- 3 Voltage limit non-Ex instrument
- 4 Supply voltage

Supply voltage – four-wire instrument	20 ... 72 V DC, 20 ... 253 V AC, 50/60 Hz
Power consumption – four-wire instrument	max. 4 VA; max. 2.1 W

Electrical protective measures

Protection	
– Housing OPTISOUND 3030 C	IP 66/IP 68 (0.2 bar) ⁷⁾
– Housing OPTISOUND 3030 C - 3050 C	IP 66/IP 67
– Transducer	IP 68
Overvoltage category	III
Protection class	
– two-wire, Profibus PA, Foundation Fieldbus	II
– four-wire	I

Approvals OPTISOUND 3040 C and 3050 C⁸⁾⁹⁾

ATEX	ATEX II 1/2D IP66 T
------	---------------------

CE conformity

EMC (89/336/EWG)	Emission EN 61326: 1997 (class A), susceptibility EN 61326: 1997/A1: 1998
LVD (73/23/EWG)	EN 61010-1: 2001

⁷⁾ Requirement to maintain the housing protection is the suitable cable.
⁸⁾ Deviating data with Ex applications: see separate safety instructions.
⁹⁾ Depending on order specification.

7 Dimensions

Housing

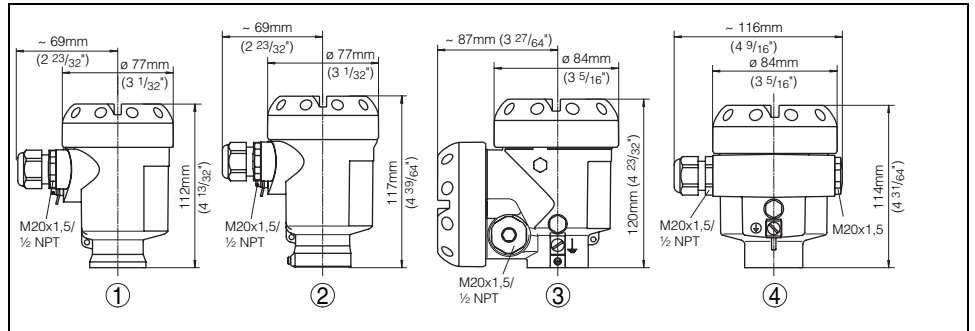

Fig. 26: Housing versions (with integrated indicating/adjustment module the housing height or width is increased by 9 mm/0.35 in)

- 1 Plastic housing
- 2 Stainless steel housing
- 3 Aluminium double chamber housing
- 4 Aluminium housing

OPTISOUND 3030 C

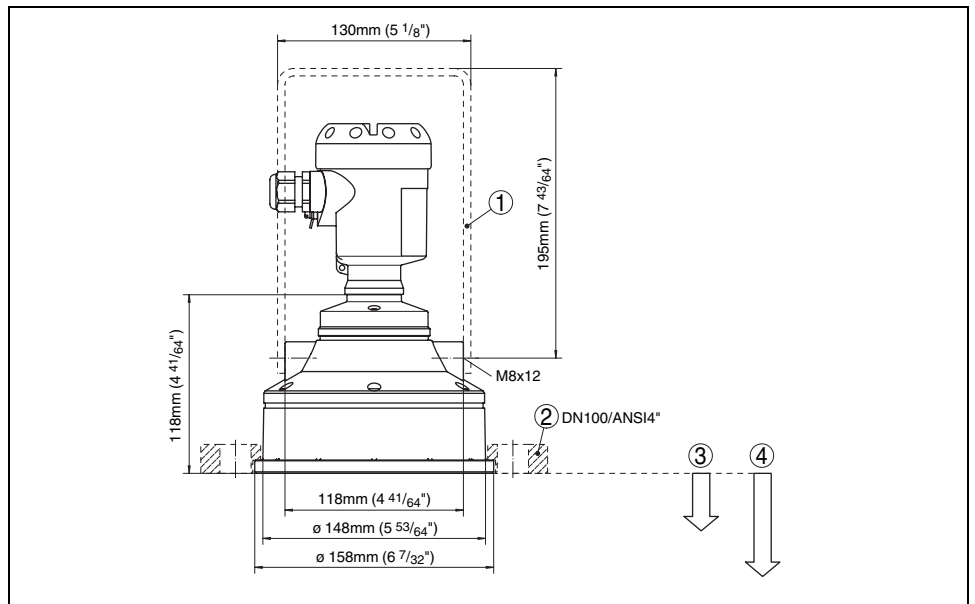

Fig. 27: OPTISOUND 3030 C

- 1 Mounting strap
- 2 Compression flange
- 3 Dead zone: 0.6 m (2 ft)
- 4 Meas. range: in liquids up to 15 m (49.2 ft), in solids up to 7 m (23 ft)

OPTISOUND 3040 C

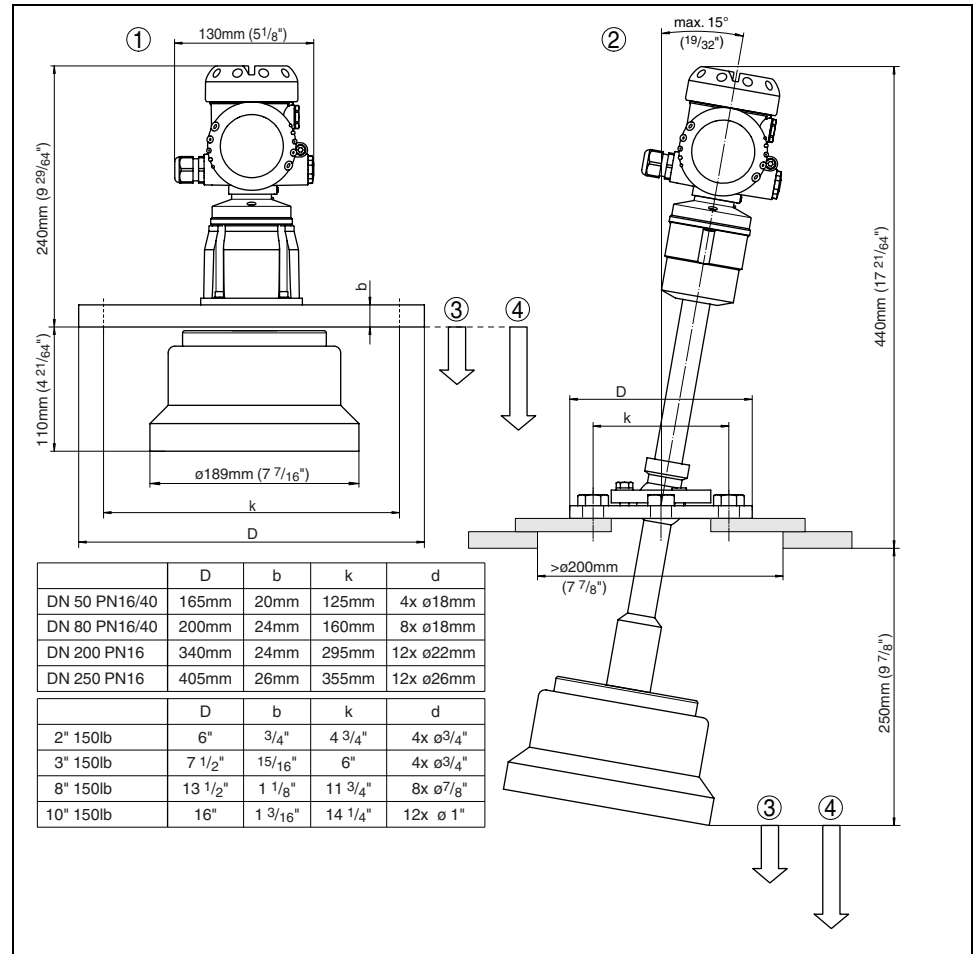

Fig. 28: OPTISOUND 3040 C

- 1 Version A
- 2 Version B
- 3 Dead zone: 1 m (3.3 ft)
- 4 Measuring range: with liquids up to 25 m (82 ft), with solids up to 15 m (49.2 ft)

OPTISOUND 3040 C

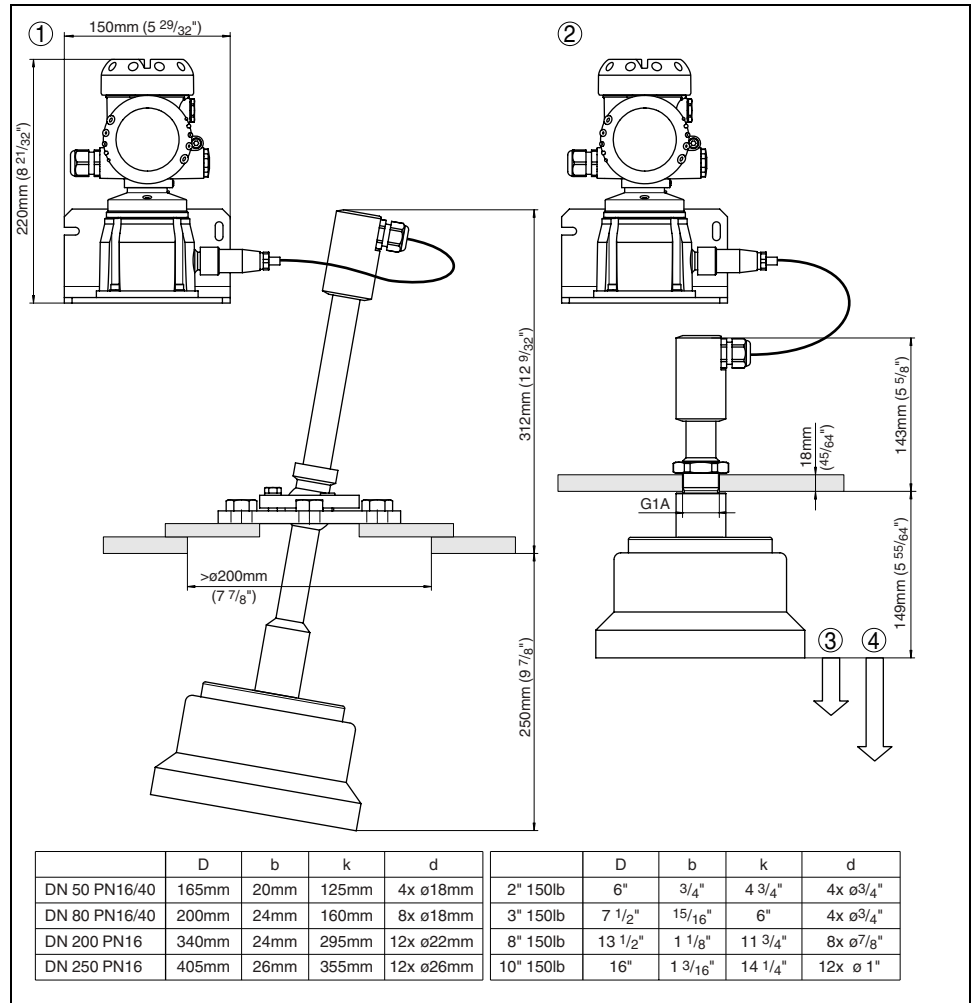

Fig. 29: OPTISOUND 3040 C

- 1 Version C
- 2 Version D
- 3 Dead zone: 1 m (3.3 ft)
- 4 Measuring range: with liquids up to 25 m (82 ft), with solids up to 15 m (49.2 ft)

OPTISOUND 3050 C

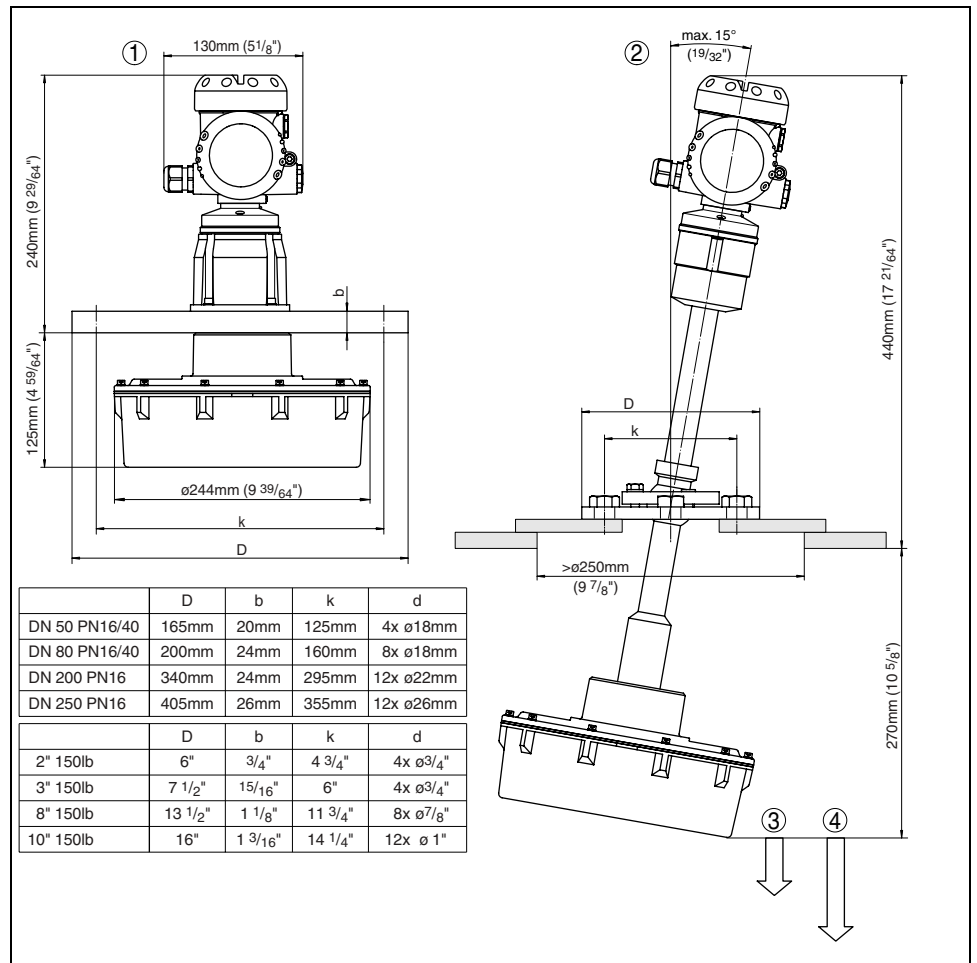

Fig. 30: OPTISOUND 3050 C

- 1 Version A
- 2 Version B
- 3 Dead zone: 0.8 m (2.6 ft)
- 4 Measuring range: with liquids up to 45 m (147.6 ft), with solids up to 25 m (82 ft)

OPTISOUND 3050 C

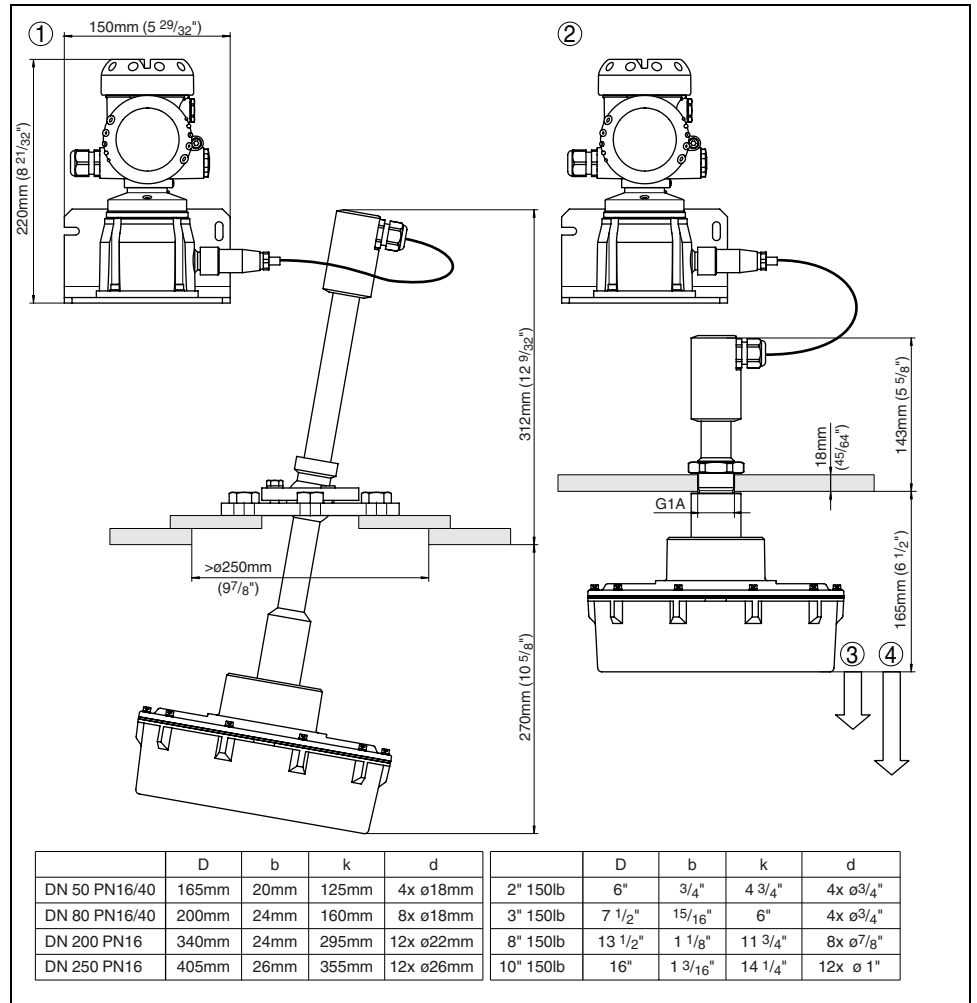

Fig. 31: OPTISOUND 3050 C

- 1 Version C
- 2 Version D
- 3 Dead zone: 0.8 m (2.6 ft)
- 4 Measuring range: with liquids up to 45 m (147.6 ft), with solids up to 25 m (82 ft)