



OPTISONIC 6300 Handbook

Ultrasonic clamp-on flowmeter

ER 3.4.0_

All rights reserved. It is prohibited to reproduce this documentation, or any part thereof, without the prior written authorisation of KROHNE Messtechnik GmbH & Co. KG.

Subject to change without notice.

Copyright 2009 by
KROHNE Messtechnik GmbH & Co. KG - Ludwig-Krohne-Straße 5 - 47058 Duisburg

1	Safety instructions	6
1.1	Software history	6
1.2	Intended use	6
1.3	Certification	6
1.4	Safety instructions from the manufacturer	8
1.4.1	Copyright and data protection	8
1.4.2	Disclaimer	8
1.4.3	Product liability and warranty	9
1.4.4	Information concerning the documentation	9
1.4.5	Warnings and symbols used	10
1.5	Safety instructions for the operator	10
2	Device description	11
2.1	Scope of delivery	11
2.2	Device description	12
2.3	Nameplates	13
2.3.1	Overview	13
2.3.2	Flow sensor	13
2.3.3	Signal converter	14
2.3.4	Electrical connection data of inputs/outputs (example of basic version)	15
3	Installation	16
3.1	Notes on installation	16
3.2	Storage	16
3.3	Transport	16
3.4	Pre-installation requirements	16
3.4.1	Environmental requirements	16
3.4.2	Installation requirements signal converter	17
3.5	Installation requirements sensor	17
3.5.1	Inlet, outlet and recommended mounting area	18
3.5.2	Long horizontal pipes	18
3.5.3	Open feed or discharge	19
3.5.4	Down going pipeline over 5 m /16 ft length	19
3.5.5	Position of control valve	19
3.5.6	Position of pump	20
3.5.7	Pipe diameters and sensor construction	20
3.5.8	Pipe and media parameters	20
3.6	Installation of the flowmeter	21
3.6.1	General mechanical installation	21
3.6.2	Installation instructions for small and medium version	23
3.6.3	Installation instructions for large version	25
3.7	Mounting of converter	27
3.7.1	Mounting of UFC 300 F	27
3.7.2	Turning the display of the field housing version	27
3.7.3	Mounting of UFC 300 W	28
4	Electrical connections	29

4.1	Safety instructions.....	29
4.2	Construction of the various housing versions	29
4.2.1	UFC 300 F	29
4.2.2	UFC 300 W	30
4.3	Electrical connection	31
4.3.1	Signal cable to flow sensor.....	31
4.3.2	Signal cable and power supply signal converter.....	33
4.3.3	Laying electrical cables correctly.....	35
4.4	Description of the electrical symbols	36
4.5	Basic inputs and outputs	37
4.5.1	Fixed, non-alterable input/output versions.....	38
4.5.2	Basic inputs/outputs	40
4.5.3	HART® connection	43
4.6	Modular Inputs and Outputs.....	44
4.6.1	Alterable input/output versions.....	44
4.6.2	Modular inputs/outputs and bus systems	46
4.6.3	HART® connection	54
5 Start-up		56
<hr/>		
5.1	General instructions for programming.....	56
5.2	Start measurement of small / medium version	60
5.3	Start measurement of large version.....	61
5.4	Mechanical installation for large version	63
6 Operation		73
<hr/>		
6.1	Menu overview	73
6.2	Menu structure	74
6.2.1	Quick setup.....	74
6.2.2	Test.....	76
6.2.3	Setup	78
6.2.4	Customize settings	85
6.3	Function description.....	86
6.4	Error messages	93
7 Service		95
<hr/>		
7.1	Periodic maintenance.....	95
7.1.1	Regreasing of transducers	95
7.2	Cleaning	96
7.3	Exchange of electronics unit	96
7.3.1	Field version.....	97
7.3.2	Wall version.....	99
7.4	Replacing the mains fuse	102
7.4.1	Field version.....	103
7.4.2	Wall version.....	103
7.5	Spare parts availability	104
7.6	Availability of services	104
7.7	Returning the device to the manufacturer.....	104
7.7.1	General information.....	104

7.7.2 Form (for copying) to accompany a returned device.....	105
7.8 Disposal	105
8 Technical data	106
<hr/>	
8.1 Measuring principle.....	106
8.2 Technical data.....	107
8.3 Dimensions and weights	115
8.3.1 Housing	115
8.3.2 Clamp-on sensor and cable box	116
8.3.3 Mounting plate, field housing	118
8.3.4 Mounting plate, wall-mounted housing	118
9 Notes	119
<hr/>	

1.1 Software history

For all GDC devices, the "Electronic Revision" (ER) is consulted to document the revision status of the electronics according to NE 53. It is easy to see from the ER whether any fault repairs or major changes to the electronic equipment have taken place and what effect they have had on compatibility.

Changes and effect on compatibility

1	Downwards compatible changes and fault repair with no effect on operation (e.g. spelling mistakes on display)	
2- _	Downwards compatible hardware and/or software change of interfaces:	
	H	HART®
	P	PROFIBUS
	F	Foundation Fieldbus
	M	Modbus
	X	all interfaces
3- _	Downwards compatible hardware and/or software change of inputs and outputs:	
	I	Current output
	F, P	Frequency / pulse output
	S	Status output
	C	Control input
	CI	Current input
	X	all inputs and outputs
4	Downwards compatible changes with new functions	
5	Incompatible changes, i.e. electronic equipment must be changed.	



INFORMATION!

In the table below, "x" is a placeholder for possible multi-digit alphanumeric combinations, depending on the available version.

1.2 Intended use

The overall functionality of the clamp-on flowmeter is the continuous measurement of actual volume flow, mass flow, flow speed, velocity of sound, gain, SNR and diagnosis value.

1.3 Certification



In accordance with the commitment to customer service and safety, the device described in this document meets the following safety requirements:

- EMC Directive 89 / 336 / EEC and 93 / 68 / EEC in conjunction with EN 61326-1 (1997) and A1 (1998), A2 (2001)
- Low-Voltage Directives 73 / 23 / EEC and 93 / 68 / EEC in conjunction with EN 61010-1 (2001)

All devices are based on the CE marking and meet the requirements of NAMUR Guideline NE 21 / 04.



DANGER!

For devices used in hazardous areas, additional safety notes apply; please refer to the Ex documentation.

1.4 Safety instructions from the manufacturer

1.4.1 Copyright and data protection

The contents of this document have been created with great care. Nevertheless, we provide no guarantee that the contents are correct, complete or up-to-date.

The contents and works in this document are subject to German copyright. Contributions from third parties are identified as such. Reproduction, processing, dissemination and any type of use beyond what is permitted under copyright requires written authorisation from the respective author and/or the manufacturer.

The manufacturer tries always to observe the copyrights of others, and to draw on works created in-house or works in the public domain.

The collection of personal data (such as names, street addresses or e-mail addresses) in the manufacturer's documents is always on a voluntary basis whenever possible. Whenever feasible, it is always possible to make use of the offerings and services without providing any personal data.

We draw your attention to the fact that data transmission over the Internet (e.g. when communicating by e-mail) may involve gaps in security. It is not possible to protect such data completely against access by third parties.

We hereby expressly prohibit the use of the contact data published as part of our duty to publish an imprint for the purpose of sending us any advertising or informational materials that we have not expressly requested.

1.4.2 Disclaimer

The manufacturer will not be liable for any damage of any kind by using its product, including, but not limited to direct, indirect, incidental, punitive and consequential damages.

This disclaimer does not apply in case the manufacturer has acted on purpose or with gross negligence. In the event any applicable law does not allow such limitations on implied warranties or the exclusion of limitation of certain damages, you may, if such law applies to you, not be subject to some or all of the above disclaimer, exclusions or limitations.

Any product purchased from the manufacturer is warranted in accordance with the relevant product documentation and our Terms and Conditions of Sale.

The manufacturer reserves the right to alter the content of its documents, including this disclaimer in any way, at any time, for any reason, without prior notification, and will not be liable in any way for possible consequences of such changes.

1.4.3 Product liability and warranty

The operator shall bear responsibility for the suitability of the device for the specific purpose. The manufacturer accepts no liability for the consequences of misuse by the operator. Improper installation and operation of the devices (systems) will cause the warranty to be void. The respective "Standard Terms and Conditions" which form the basis for the sales contract shall also apply.

1.4.4 Information concerning the documentation

To prevent any injury to the user or damage to the device it is essential that you read the information in this document and observe applicable national standards, safety requirements and accident prevention regulations.

If this document is not in your native language and if you have any problems understanding the text, we advise you to contact your local office for assistance. The manufacturer can not accept responsibility for any damage or injury caused by misunderstanding of the information in this document.

This document is provided to help you establish operating conditions, which will permit safe and efficient use of this device. Special considerations and precautions are also described in the document, which appear in the form of underneath icons.

1.4.5 Warnings and symbols used

Safety warnings are indicated by the following symbols.



DANGER!

This information refers to the immediate danger when working with electricity.



DANGER!

This warning refers to the immediate danger of burns caused by heat or hot surfaces.



DANGER!

This warning refers to the immediate danger when using this device in a hazardous atmosphere.



DANGER!

These warnings must be observed without fail. Even partial disregard of this warning can lead to serious health problems and even death. There is also the risk of seriously damaging the device or parts of the operator's plant.



WARNING!

Disregarding this safety warning, even if only in part, poses the risk of serious health problems. There is also the risk of damaging the device or parts of the operator's plant.



CAUTION!

Disregarding these instructions can result in damage to the device or to parts of the operator's plant.



INFORMATION!

These instructions contain important information for the handling of the device.



LEGAL NOTICE!

This note contains information on statutory directives and standards.



• **HANDLING**

This symbol designates all instructions for actions to be carried out by the operator in the specified sequence.

➔ **RESULT**

This symbol refers to all important consequences of the previous actions.

1.5 Safety instructions for the operator



WARNING!

*In general, devices from the manufacturer may only be installed, commissioned, operated and maintained by properly trained and authorized personnel.
This document is provided to help you establish operating conditions, which will permit safe and efficient use of this device.*

2.1 Scope of delivery



INFORMATION!

Check the packing list to check if you received completely all that you ordered.



INFORMATION!

Inspect the cartons carefully for damage or signs of rough handling. Report damage to the carrier and to the local office of the manufacturer.



INFORMATION!

The device will arrive in two cartons. The square carton contains the converter. The rectangular carton contains the transducer set.

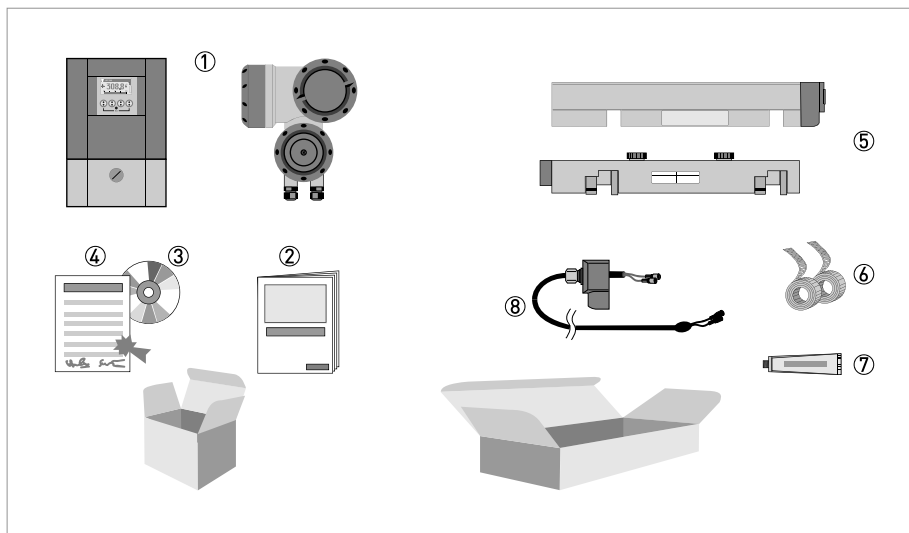
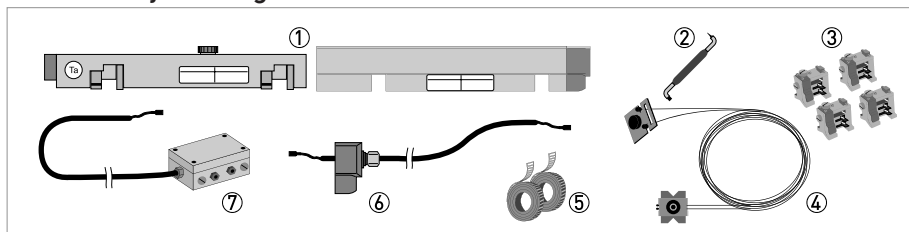

Figure 2-1: Scope of delivery

- ① Signal converter, wall version or field version
- ② Quick Start
- ③ CD-ROM (including Handbook, Quick Start, Technical Datasheet, Support database, movie)
- ④ Factory calibration report
- ⑤ Sensor plus cover (stainless steel / XT version without cover)
- ⑥ Metal strap
- ⑦ Mineral coupling grease (standard versions) or high temperature contactgel Pyrogel® (XT versions)
- ⑧ Signal cable plus connector cap (XT versions have a protection sleeve around the signal cable).

Additionally for large version:



- ① 2nd sensor plus cover
- ② 90 degree screw driver
- ③ 4 fixing units
- ④ Positioning tool
- ⑤ 2 metal straps
- ⑥ Signal cable plus connector cap
- ⑦ Cable box plus signal cable

**INFORMATION!**

No special tools, no training required!

2.2 Device description

The ultrasonic clamp-on flowmeter can be fitted on the outside of piping to measure the flow rate of liquids.

The device is a combination of one up to two clamp-on sensor(s) and one ultrasonic flow converter.

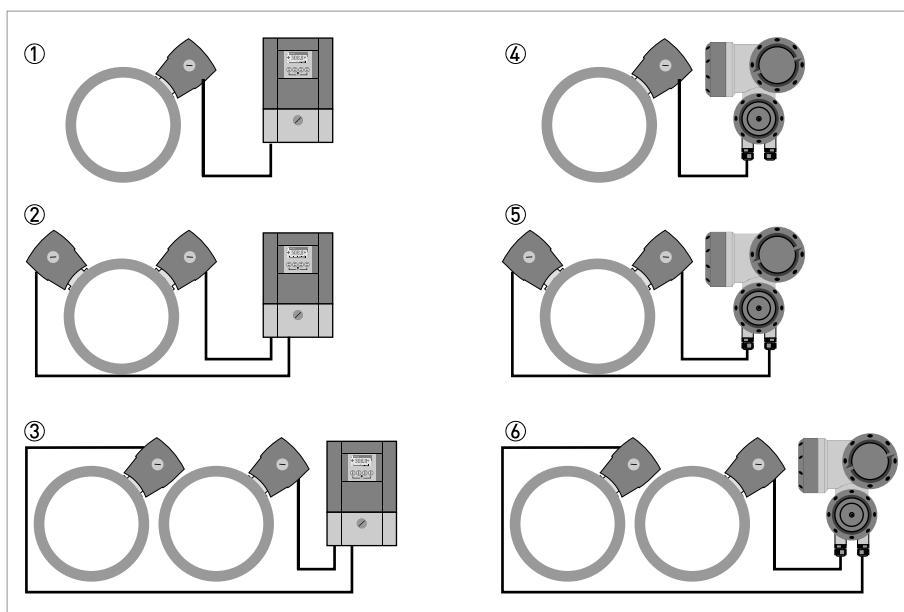

Figure 2-2: System configuration possibilities

The underneath accessories can be ordered optionally:

- GDC interface set
- SoundCheck
- Coupling grease; mineral (standard versions)
- High temperature contact gel Pyrogel® (XT versions)

2.3 Nameplates



INFORMATION!

Look at the device nameplate to ensure that the device is delivered according to your order. Check for the correct supply voltage printed on the nameplate.

2.3.1 Overview

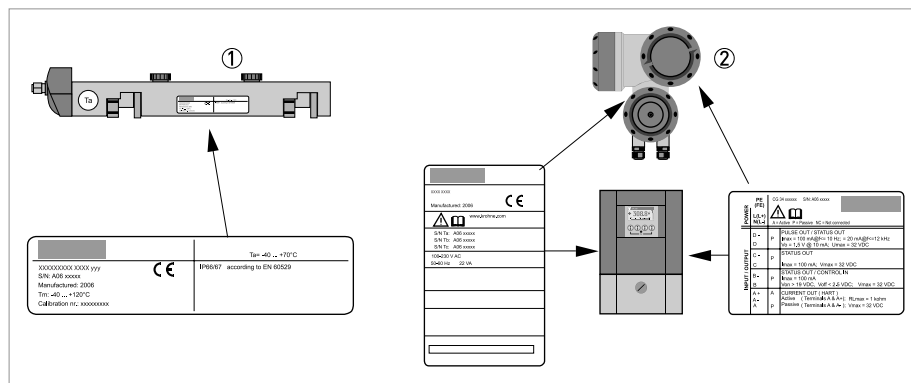

Figure 2-3: Visual check

- ① Flow sensor
- ② Signal converter

2.3.2 Flow sensor

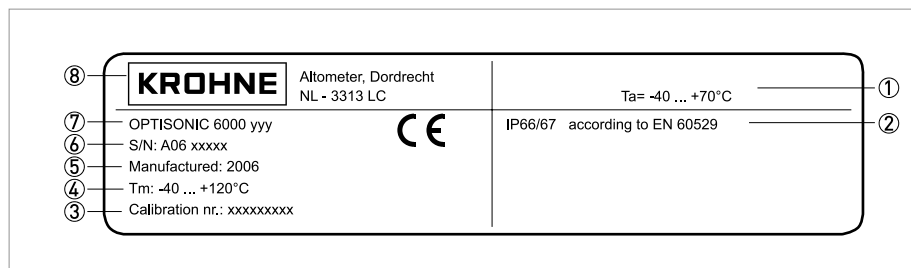

Figure 2-4: Nameplate flow sensor

- ① Ambient temperature operating range
- ② Protection category
- ③ Calibration number
- ④ Process temperature [-40...+200°C for XT version]
- ⑤ Manufacturing year
- ⑥ Serial number
- ⑦ Device type (yyy = small, medium or large)
- ⑧ Manufacturer

2.3.3 Signal converter

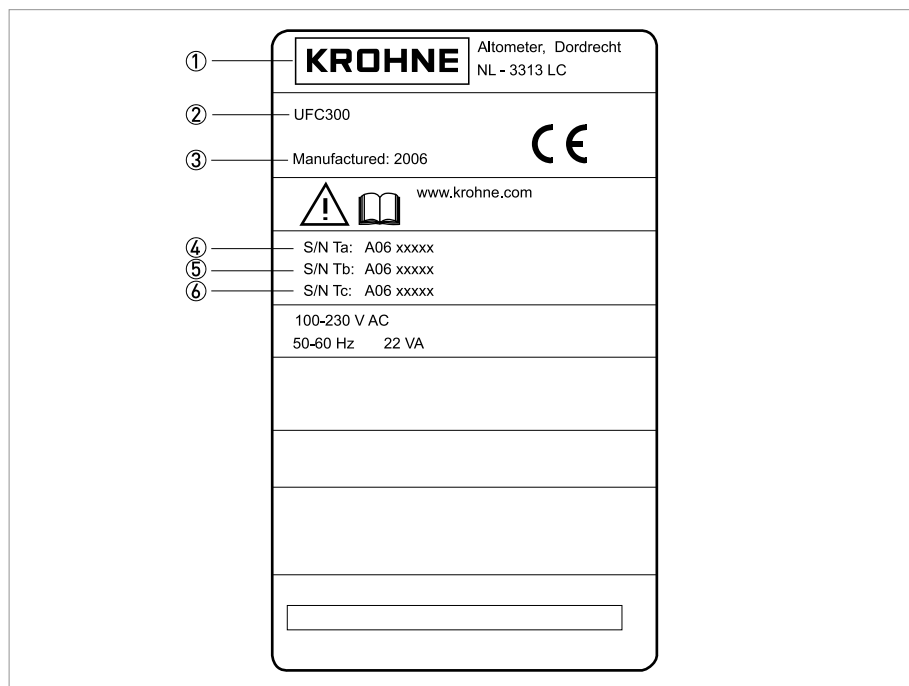

Figure 2-5: Nameplate

- ① Manufacturer
- ② Device type
- ③ Manufacturing year
- ④ Serial number sensor 1 + short code flow sensor
- ⑤ Serial number sensor 2 + short code flow sensor
- ⑥ Empty

2.3.4 Electrical connection data of inputs/outputs (example of basic version)



①	POWER	PE (FE)	CG 3x xxxxxx S/N: A06 xxxxx	
		L(L+) N(L-)	  A = Active P = Passive NC = Not connected	
②	INPUT / OUTPUT	D -	P	PULSE OUT / STATUS OUT
		D		$I_{max} = 100 \text{ mA}@f \leq 10 \text{ Hz}; = 20 \text{ mA}@f \leq 12 \text{ kHz}$ $V_o = 1,5 \text{ V @ } 10 \text{ mA}; U_{max} = 32 \text{ VDC}$
③	INPUT / OUTPUT	C -	P	STATUS OUT
		C		$I_{max} = 100 \text{ mA}; V_{max} = 32 \text{ VDC}$
④	INPUT / OUTPUT	B -	P	STATUS OUT / CONTROL IN
		B		$I_{max} = 100 \text{ mA}$ $V_{on} > 19 \text{ VDC}, V_{off} < 2,5 \text{ VDC}; V_{max} = 32 \text{ VDC}$
⑤	INPUT / OUTPUT	A +	A	CURRENT OUT (HART)
		A - A	P	Active (Terminals A & A+); $R_{Lmax} = 1 \text{ kohm}$ Passive (Terminals A & A-); $V_{max} = 32 \text{ VDC}$

Figure 2-6: Example of a nameplate for electrical connection data of inputs and outputs

- ① Power supply (AC: L and N; DC: L+ and L-; PE for $\geq 24 \text{ VAC}$; FE for $\leq 24 \text{ VAC}$ and DC)
- ② Connection data of connection terminal D/D-
- ③ Connection data of connection terminal C/C-
- ④ Connection data of connection terminal B/B-
- ⑤ Connection data of connection terminal A/A-; A+ only operable in the basic version

- A = active mode; the signal converter supplies the power for connection of the subsequent devices
- P = passive mode; external power supply required for operation of the subsequent devices
- N/C = connection terminals not connected

3.1 Notes on installation

**INFORMATION!**

Inspect the cartons carefully for damage or signs of rough handling. Report damage to the carrier and to the local office of the manufacturer.

**INFORMATION!**

Check the packing list to check if you received completely all that you ordered.

**INFORMATION!**

Look at the device nameplate to ensure that the device is delivered according to your order. Check for the correct supply voltage printed on the nameplate.

3.2 Storage

- Store the flowmeter in a dry and dust-free location.
- Avoid lasting direct exposure to the sun.
- Store the flowmeter in its original packing.

3.3 Transport

No special requirements.

3.4 Pre-installation requirements

**INFORMATION!**

To assure a quick, safe and uncomplicated installation, we kindly request you to make provisions as stated below.

3.4.1 Environmental requirements

- Pollution degree 2
- Protection class I
- Humidity: 5...80 % RH
- Temperature: $-40...+60^{\circ}\text{C}$ / $-40...+140^{\circ}\text{F}$ operating and $-50...+70^{\circ}\text{C}$ / $-58...+158^{\circ}\text{F}$ storage
- Suitable for indoor and outdoor use and certified for operating up to an altitude of 2000 m / 6562 ft
- IP class 66/67

**CAUTION!**

The device should be protected from corrosive chemicals or gases and dust / particles accumulation.

3.4.2 Installation requirements signal converter

- Allow 10...20 cm / 3.9...7.9" of space at the sides and rear of the signal converter to permit free air circulation.
- Protect signal converter against direct solar radiation, install a sunshield if necessary.
- Signal converters installed in switchgear cabinets require adequate cooling, e.g. by fan or heat exchanger.
- Do not expose the signal converter to intense vibration.

**INFORMATION!**

For detailed information please also refer to Housing on page 115.

3.5 Installation requirements sensor

**INFORMATION!**

To avoid measuring errors and malfunctioning of the flowmeter due to gas or air inclusions or an empty pipe, please observe the following precautions.

**CAUTION!**

Since gas will collect at the highest point of a pipe, installation of the flowmeter at that location should be avoided at all times. Also installation in a down going pipe should be avoided since a completely filled pipe may not be guaranteed due to cascading effects. Additionally flow profile distortion is possible.

**CAUTION!**

If you program the diameter, please note that you use the outer diameter of the pipe.

3.5.1 Inlet, outlet and recommended mounting area

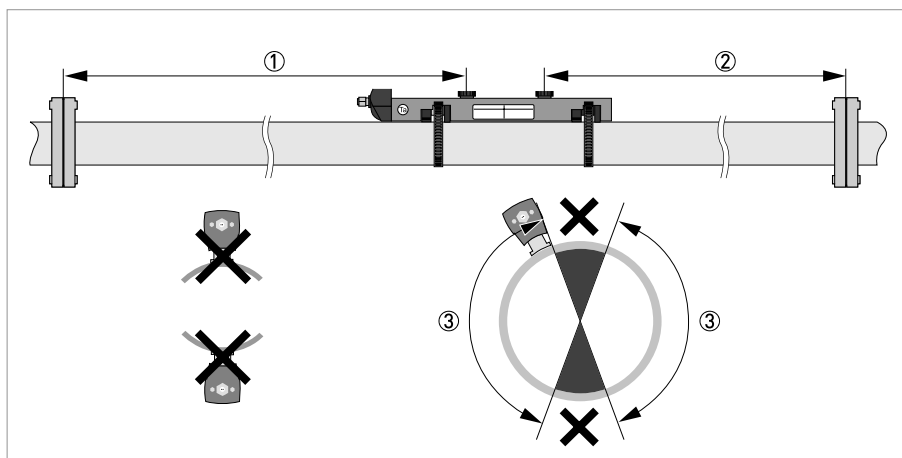

Figure 3-1: Inlet, outlet and recommended mounting area

- ① Min. 10 DN
- ② Min. 5 DN
- ③ OK, 120°

**CAUTION!*****Especially for XT (eXtended Temperature) versions:***

- *Always install the sensor at a non-insulated part of the pipe. Remove any insulation if necessary!*
- *Bend radius of cable plus connection box needs 10 cm / 4" additional non insulated pipe section.*
- *Always wear protection gloves.*

3.5.2 Long horizontal pipes

- Install on slightly ascending pipe section.
- If not possible, ensure adequate velocity to prevent air, gas or vapor from collecting in upper part.
- In partially filled pipes, the clamp-on flowmeter will report incorrect flow rates, or not measure.

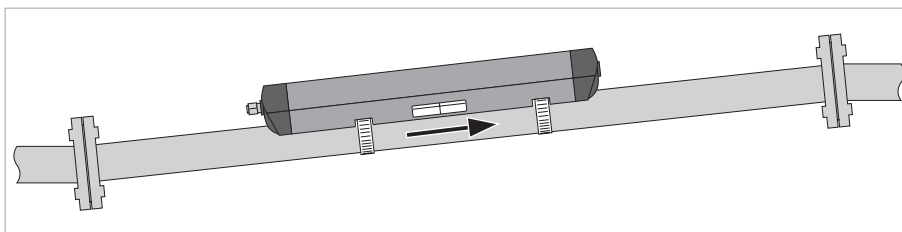

Figure 3-2: Long horizontal pipes

3.5.3 Open feed or discharge

Install meter on a lowered section of the pipe to ensure a full pipe condition through the meter.

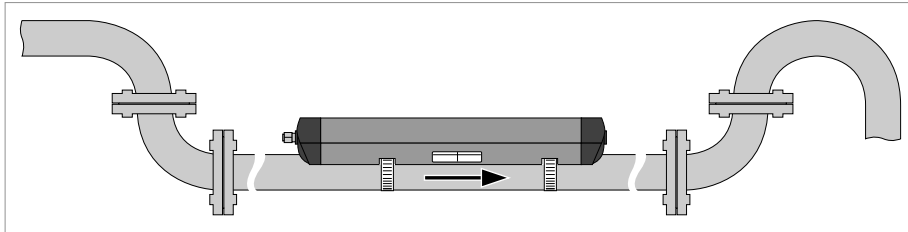

Figure 3-3: Open feed or discharge

3.5.4 Down going pipeline over 5 m /16 ft length

Install air vent downstream of the flow meter to prevent vacuum. Although this will not harm the meter, it may cause gases to come out of solution (cavitate) and interfere with proper measurements.

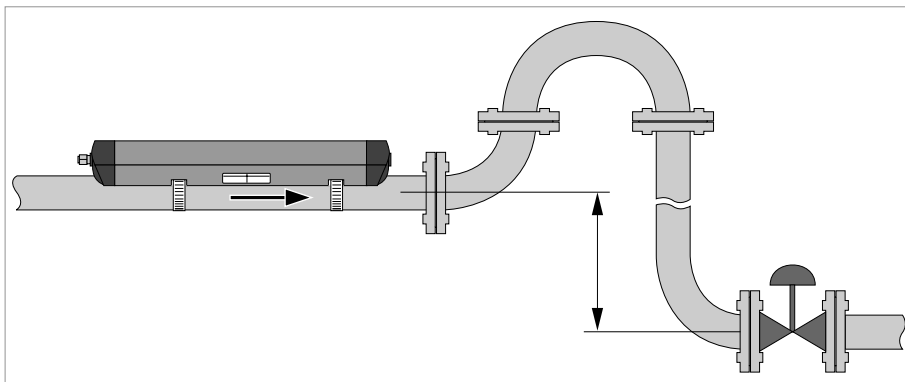

Figure 3-4: Down going pipeline over 5 m /16 ft length

3.5.5 Position of control valve

Always install control valves downstream of flowmeter in order to avoid cavitation or distortion of flow profile.

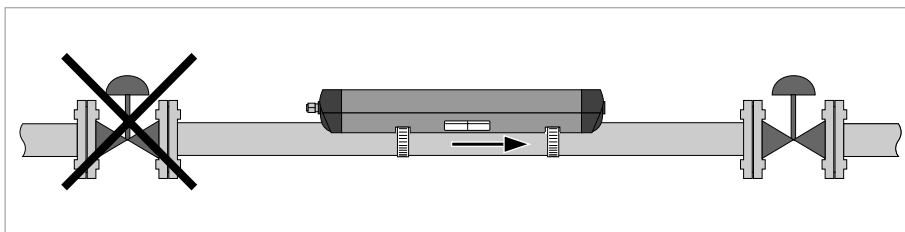

Figure 3-5: Position of control valve

3.5.6 Position of pump



CAUTION!

Never install flowmeter at a pump suction side in order to avoid cavitation or flashing in the flowmeter.

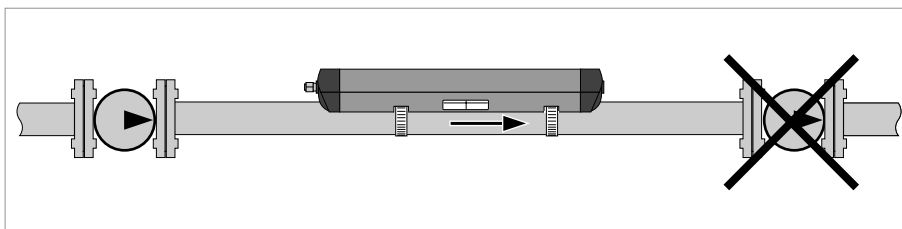

Figure 3-6: Position of pump

3.5.7 Pipe diameters and sensor construction

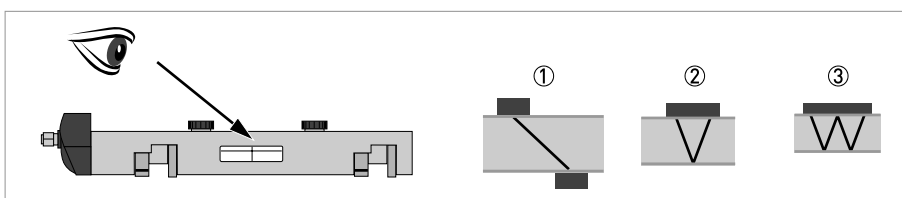

Figure 3-7: Measuring modes

- ① Z-mode
- ② V-mode
- ③ W-mode

3.5.8 Pipe and media parameters



INFORMATION!

Detailed databases of most pipe and media parameters are on the supplied CD.

3.6 Installation of the flowmeter

3.6.1 General mechanical installation

Installation of the rails with the metal straps

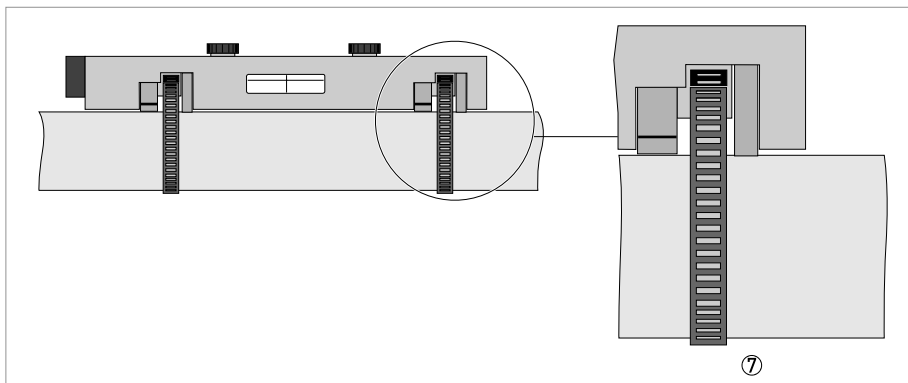
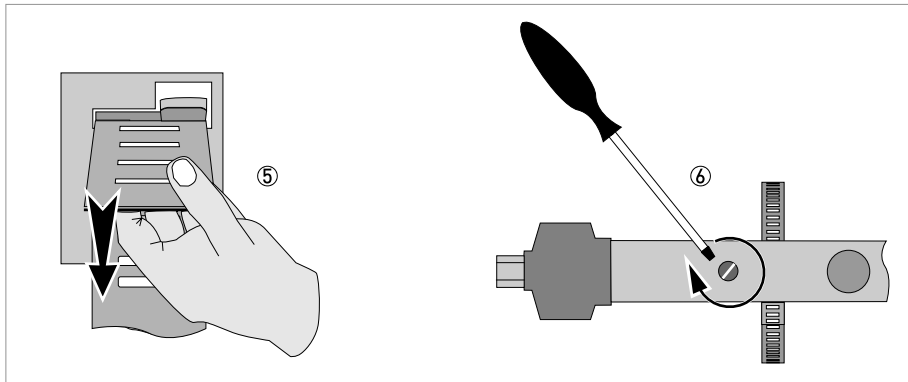
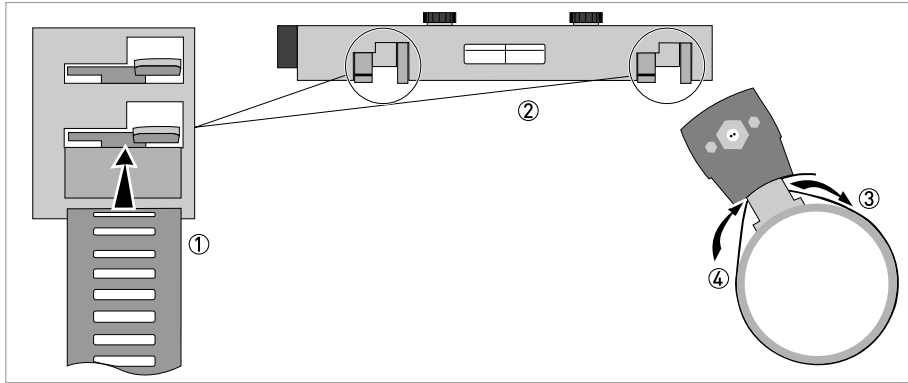

- ⑧: Repeat steps ①...⑦ at the other side of the rail.

Change the position of the transducer

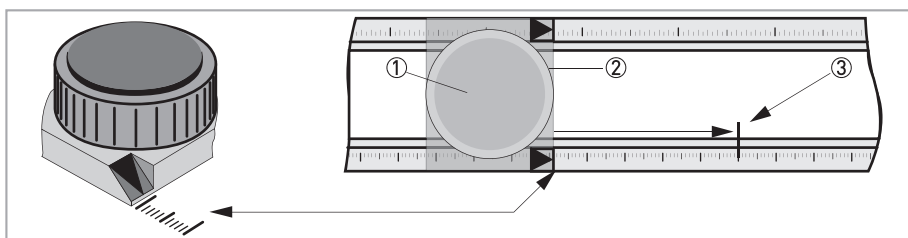

- Unlock the floating transducer ② by turning the locking knob ① counter clockwise.
- Slide the transducer ② to the advised mounting distance ③ (menu X9.4).
- Lock the transducer by turning the locking knob ① clockwise.

Greasing the transducer surfaces

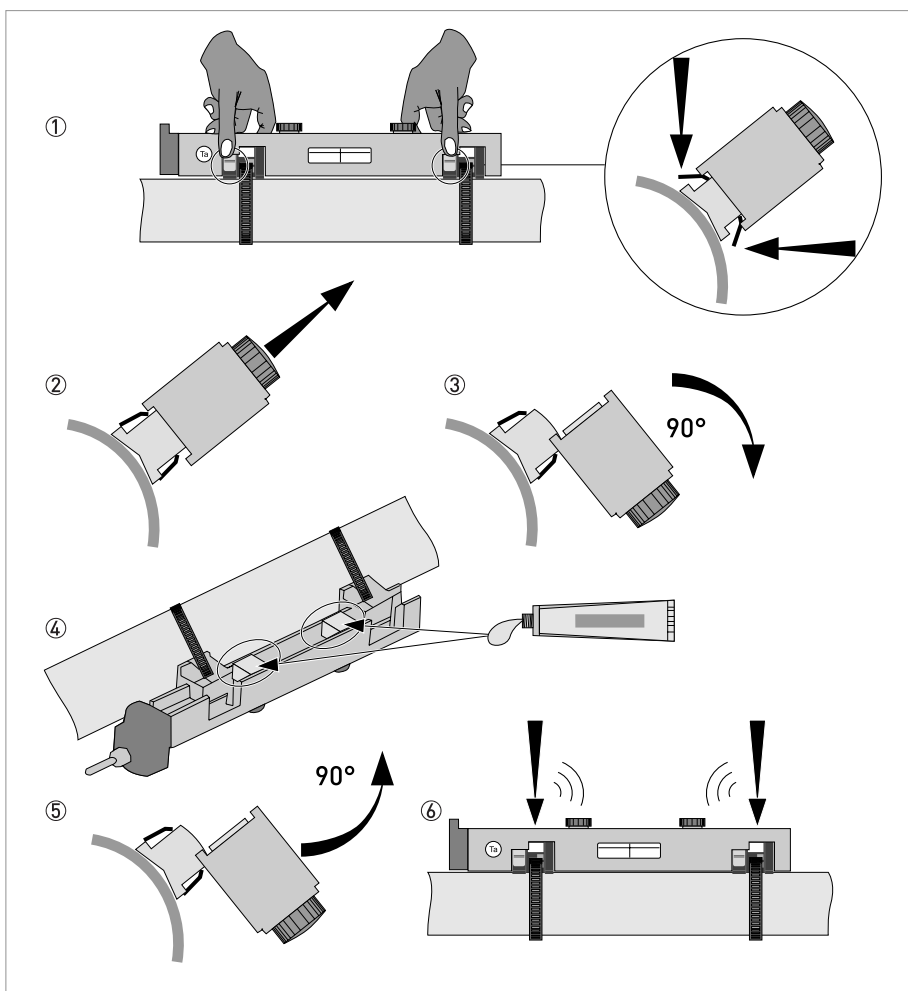

**INFORMATION!**

Not applicable for stainless steel / XT versions. These are delivered without cover.

Mounting the cover**3.6.2 Installation instructions for small and medium version**

Figure 3-8: Procedure for installation of small or medium version

- ① Rail, small version
- ② Rail, medium version
- ③ Choose for V-mode or ...
- ④ Choose for W-mode
- ⑤ Make settings in converter

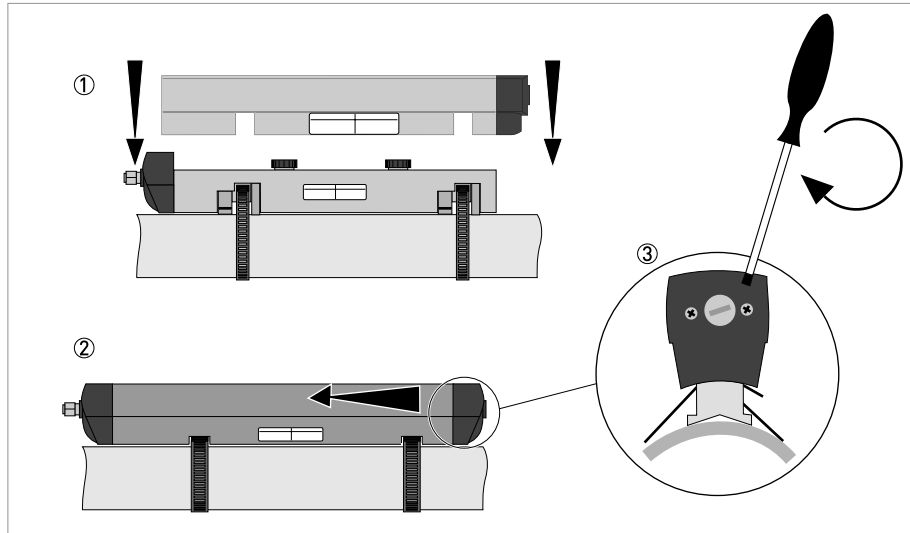
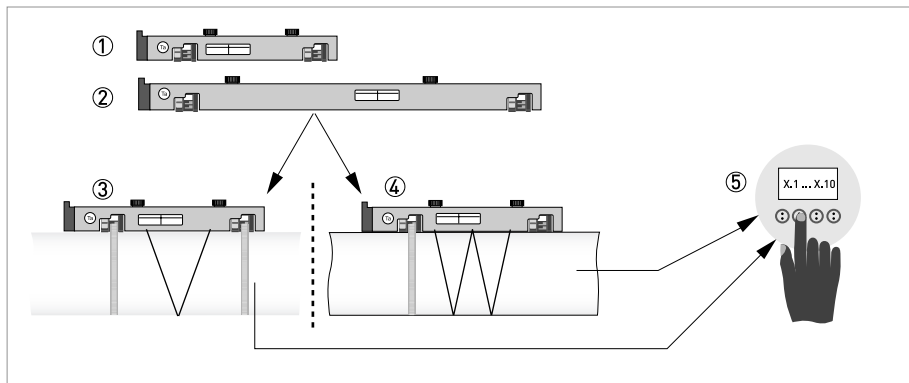
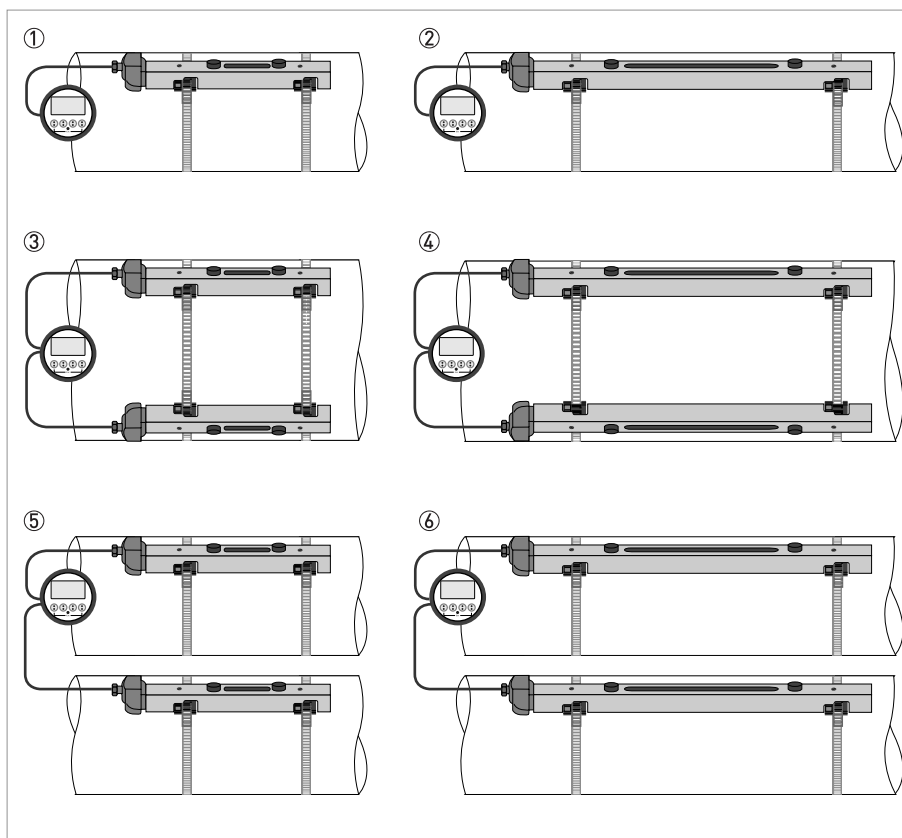

Figure 3-9: Device versions

- ① Small version: single pipe / single path
- ② Medium version: single pipe / single path
- ③ Small version: single pipe / dual path
- ④ Medium version: single pipe / dual path
- ⑤ Small version: dual pipe / single path
- ⑥ Medium version: dual pipe / single path

3.6.3 Installation instructions for large version

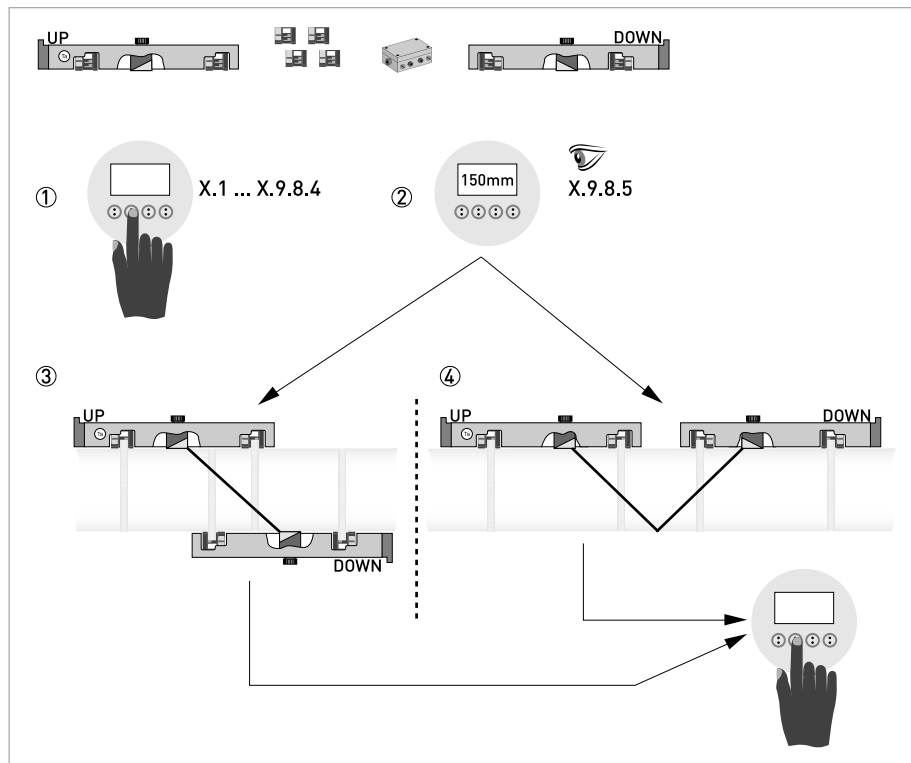

Figure 3-10: Procedure for installation of large version

- ① Enter the values for the installation menu, X1...X9.8.4
- ② Read the advised mounting distance in menu X9.8.5
- ③ Choose for Z-mode (default) or ...
- ④ Choose for V-mode
- ⑤ Finish the installation menu

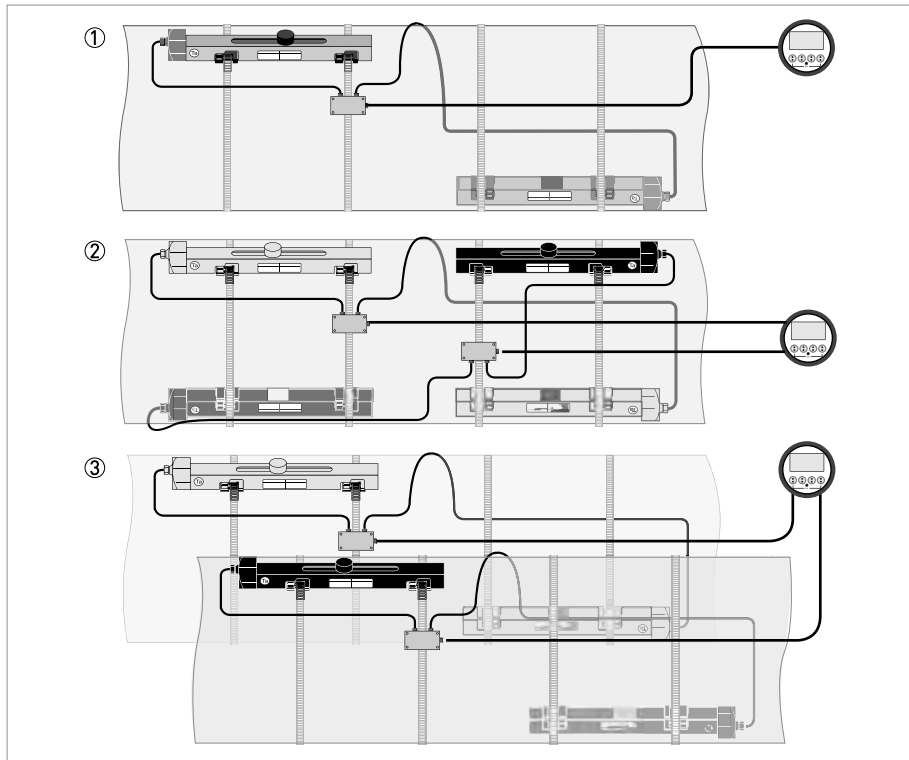

Figure 3-11: Device versions

- ① Single pipe, single path
- ② Single pipe, dual path
- ③ Dual pipe

3.7 Mounting of converter



CAUTION!

Always use the supplied signal cable. Keep the distance between the sensor and the signal converter as short as possible.

3.7.1 Mounting of UFC 300 F



Perform the following procedures:

- Mount converter with mounting plate on wall or standpipe.
- Observe maximum allowed length of 30 m / 98.4 ft for the signal cable

3.7.2 Turning the display of the field housing version

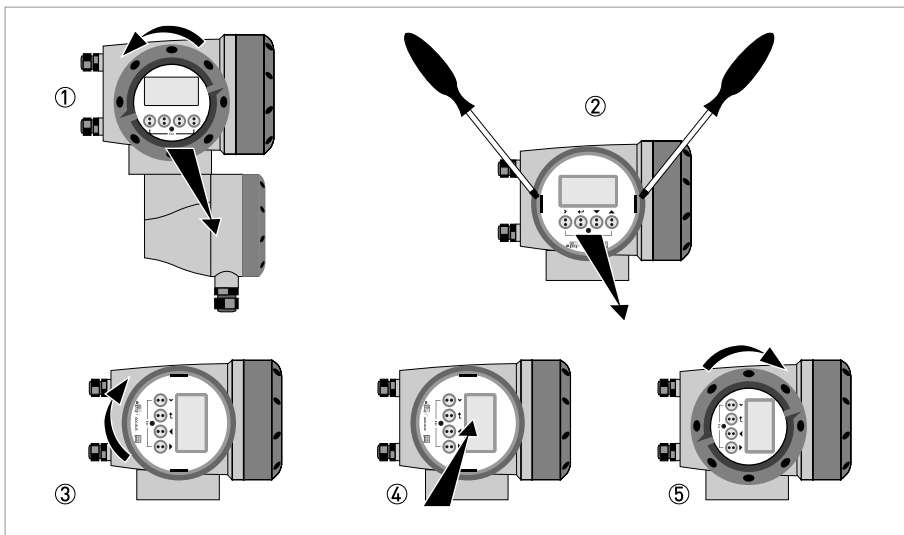

Figure 3-12: Turning the display of the field housing version



The display of the field housing version can be turned in 90° increments.

- ① Unscrew the cover from the display and operation control unit.
- ② Using a suitable tool, pull out the two metal puller devices to the left and right of the display.
- ③ Pull out the display between the two metal puller devices and rotate it to the required position.
- ④ Slide the display and then the metal puller devices back into the housing.
- ⑤ Re-fit the cover and tighten it by hand.



CAUTION!

The ribbon cable of the display must not be folded or twisted repeatedly.



INFORMATION!

Each time a housing cover is opened, the thread should be cleaned and greased. Use only resin-free and acid-free grease.

Ensure that the housing gasket is properly fitted, clean and undamaged.

3.7.3 Mounting of UFC 300 W



Perform the following procedures:

- Remove aluminium mounting plate from rear of the signal converter, and attach to wall or standpipe.
- Mount signal converter.
- Position lock washers and nuts on the housing bolts, tighten nuts slightly.
- Align housing, tighten nuts firmly.
- Observe max. allowed length of 30 m / 98.4 ft for the signal cable.

4.1 Safety instructions



DANGER!

All work on the electrical connections may only be carried out with the power disconnected. Take note of the voltage data on the nameplate!



DANGER!

Observe the national regulations for electrical installations!



DANGER!

For devices used in hazardous areas, additional safety notes apply; please refer to the Ex documentation.



WARNING!

Observe without fail the local occupational health and safety regulations. Any work done on the electrical components of the measuring device may only be carried out by properly trained specialists.



INFORMATION!

Look at the device nameplate to ensure that the device is delivered according to your order. Check for the correct supply voltage printed on the nameplate.

4.2 Construction of the various housing versions

4.2.1 UFC 300 F

The terminal compartments are accessible after unscrewing cover ② and ⑥.

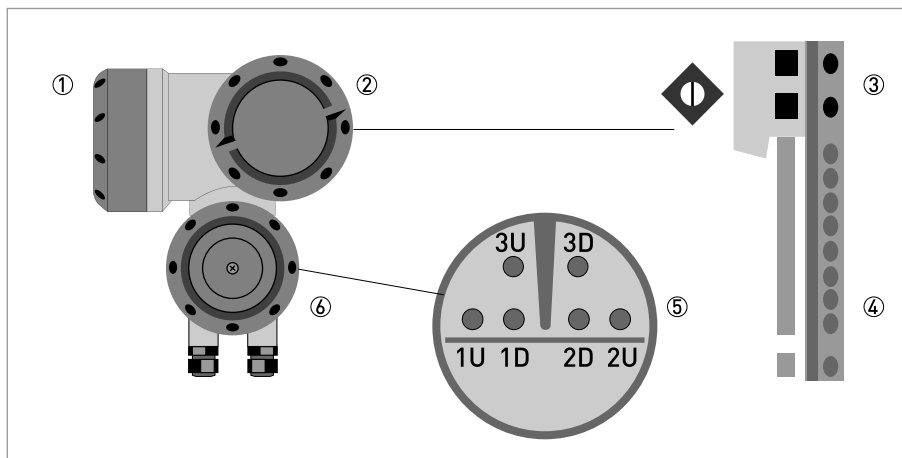

Figure 4-1: Construction (field version)

- ① Cover, electronics compartment
- ② Cover, terminal compartment for power supply and inputs/outputs
- ③ Cable entry for power
- ④ Cable entry for inputs/outputs
- ⑤ Cable entry for sensor cable
- ⑥ Cover, sensor terminal compartment

4.2.2 UFC 300 W

The terminal compartments are accessible after opening cover ②.

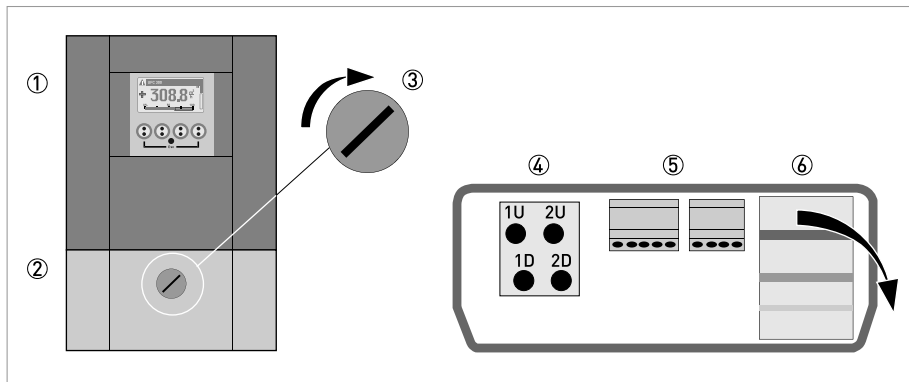

Figure 4-2: Construction of remote version

- ① Cover, electronics compartment
- ② Cover for the three separate terminal compartments for power, sensor connection and inputs/outputs
- ③ Locking screw, 1/2 turn left/right to open/close cover ②
- ④ Sensor terminal compartment
- ⑤ Terminal compartment for inputs/outputs
- ⑥ Power terminal compartment, open separate shock-hazard protection cover

4.3 Electrical connection



CAUTION!

To ensure smooth functioning, always use the signal cables included in the delivery.

The flow sensor is connected to the signal converter via the single signal cable.

4.3.1 Signal cable to flow sensor

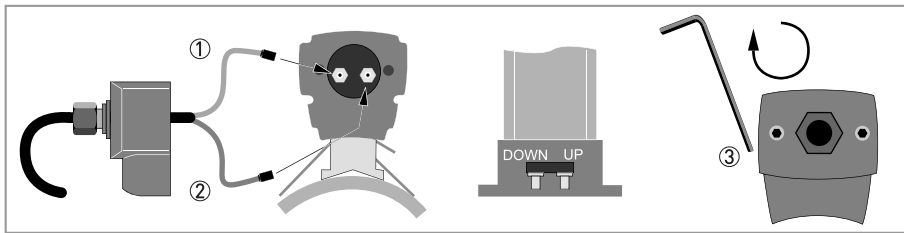

Figure 4-3: Connecting the signal cable to the rail (small and medium version)

- ① Connect the green cable to "DOWN"
- ② Connect the blue cable to "UP"
- ③ Turn the screws clockwise to secure the cap

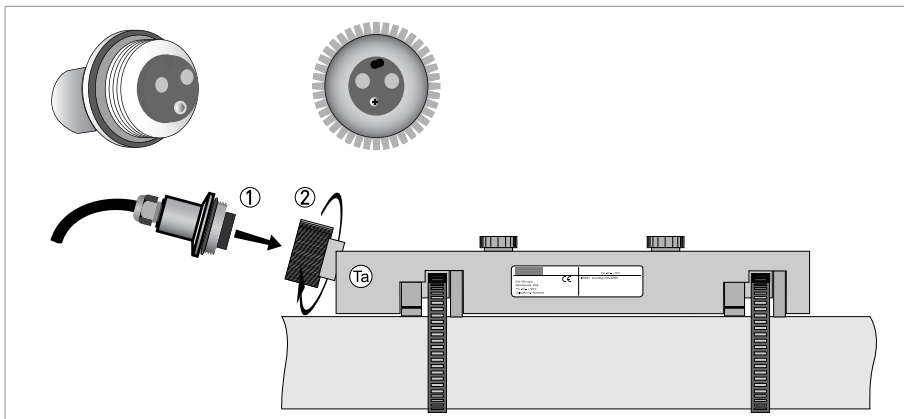

Figure 4-4: Connect the signal cable in case of stainless steel / XT version.

- ① Put in the connector.
- ② Turn knob to secure the connector.



CAUTION!

For XT versions: check if the signal cable is heat protected with the protection sleeve of 1 meter / 40".

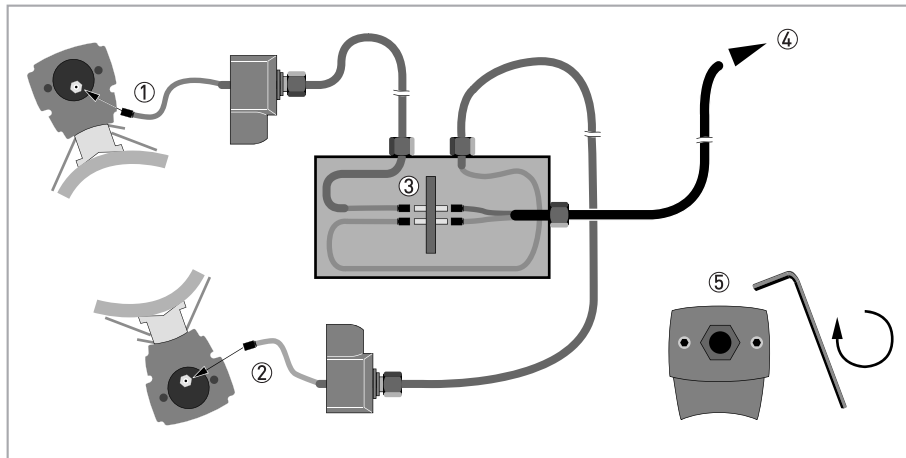

Figure 4-5: Connections in cable box (large version)

- ① Connect the blue cable to the UP rail.
- ② Connect the green cable to the DOWN rail.
- ③ Make connections in cable box.
- ④ Cable to converter
- ⑤ Turn the screws clockwise to secure the caps.

4.3.2 Signal cable and power supply signal converter



INFORMATION!

The power terminals in the terminal compartments are equipped with additional hinged lids to prevent accidental contact.



DANGER!

The device must be grounded in accordance with regulations in order to protect personnel against electric shocks.

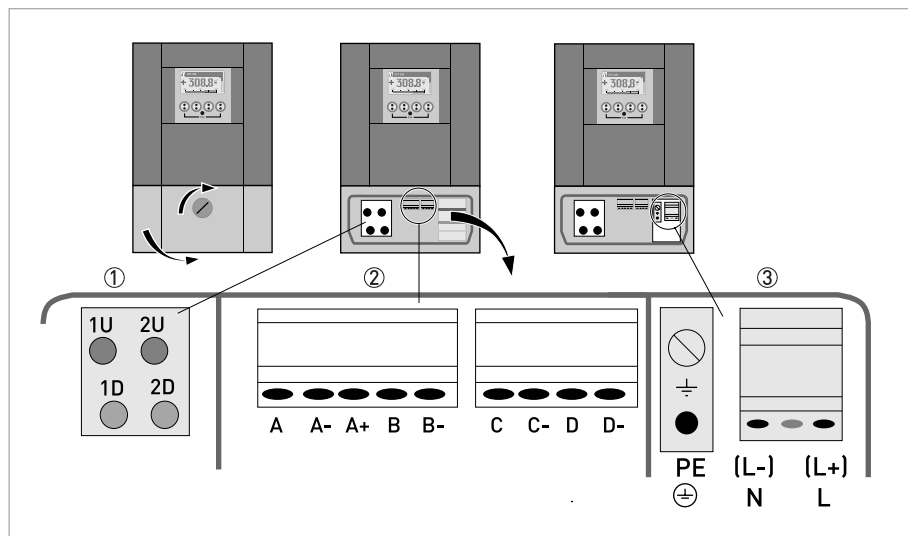

Figure 4-6: Construction of wall version

- ① Connect blue cable to 1U (to 2U for 2nd sensor) and the green cable to 1D (2D for 2nd sensor)
- ② Communication I/O
- ③ Power supply: 24 VAC/DC or 100...240 VAC

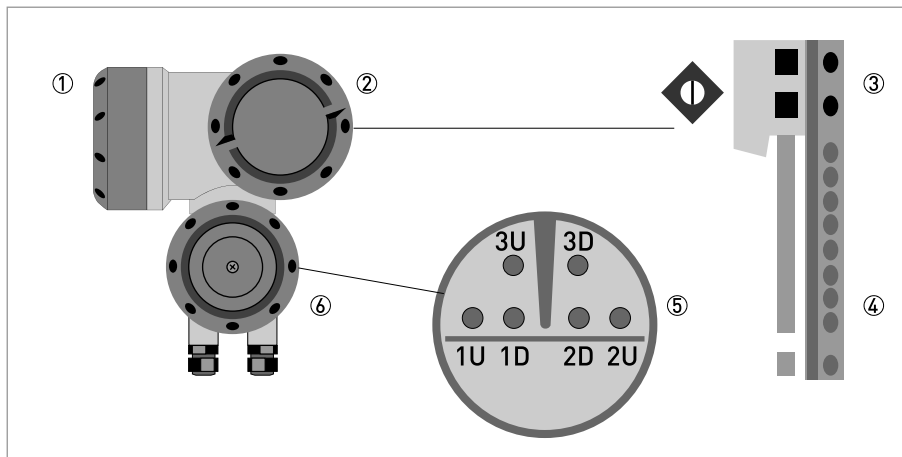

Figure 4-7: Construction (field version)

- ① Cover, electronics compartment
- ② Cover, terminal compartment for power supply and inputs/outputs
- ③ Cable entry for power
- ④ Cable entry for inputs/outputs
- ⑤ Cable entry for sensor cable
- ⑥ Cover, sensor terminal compartment

100...230 VAC (-15% / +10%)

- Connect the protective ground conductor PE of the mains power supply to the separate terminal in the terminal compartment of the signal converter.
- Connect the live conductor to the L terminal and the neutral conductor to the N terminal.

24 VAC/DC (-15% / +10%)

- For reasons to do with the measurement process, connect a functional ground FE to the separate U-clamp terminal in the terminal compartment of the signal converter.
- When connecting to functional extra-low voltages, provide a facility for protective separation (PELV) (VDE 0100 / VDE 0106 and/or IEC 364 / IEC 536 or relevant national regulations).

4.3.3 Laying electrical cables correctly

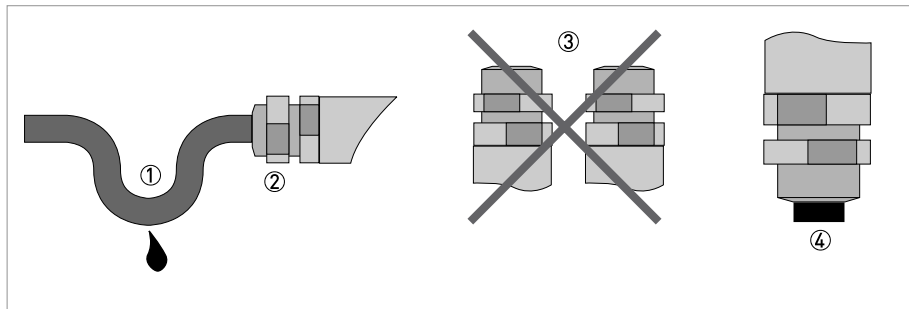

Figure 4-8: Protect housing from dust and water



- ① Lay the cable in a loop just before the housing.
- ② Tighten the screw connection of the cable entry securely.
- ③ Never mount the housing with the cable entries facing upwards.
- ④ Seal cable entries that are not needed with a plug.

4.4 Description of the electrical symbols



	mA meter 0...20 mA or 4...20 mA and other R_L is the internal resistance of the measuring point including the cable resistance
	DC voltage source (U_{ext}), external power supply, any connection polarity
	DC voltage source (U_{ext}), observe connection polarity according to connection diagrams
	Internal DC voltage source
	Controlled internal power source in the device
	Electronic or electromagnetic counter At frequencies above 100 Hz, shielded cables must be used to connect the counters. R_i Internal resistance of the counter
	Button, NO contact or similar

Table 4-1: Description of symbols

4.5 Basic inputs and outputs

The signal converter has several in / output ports, accessible via the terminal compartment for interfacing with external devices. The terminal compartment is accessible after unscrewing the cover.

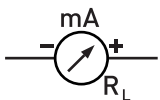
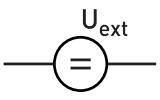
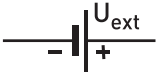
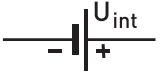
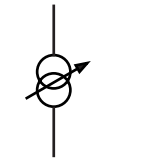
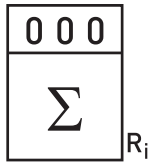
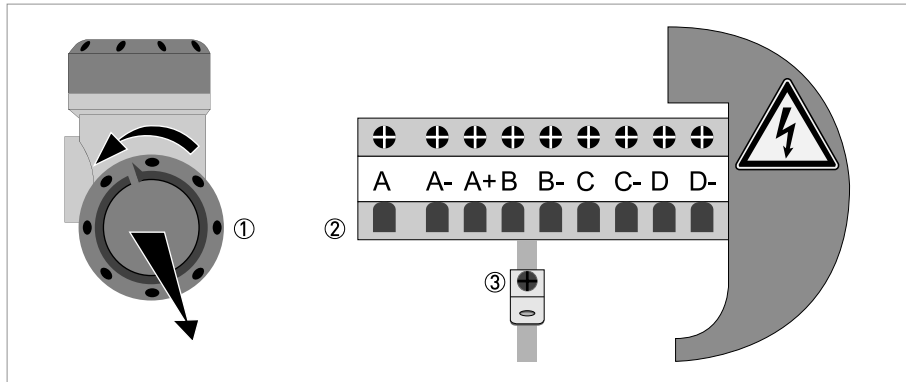

Figure 4-9: Field housing, I/O terminals

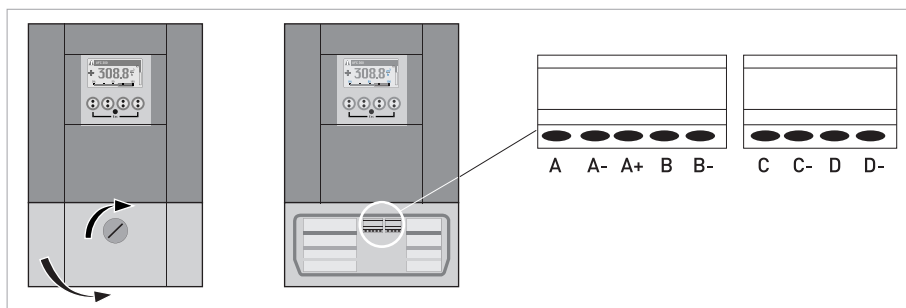

Figure 4-10: Wall housing, I/O terminals

The input / output ports are galvanic separated from each other and from all other input and output circuits.

- **Active I/O:** the UFC 300 signal converter supplies the power for operation
- **Passive I/O:** an external power supply is required

Basic I/O consisting of:

- 1 current output,
- 1 pulse output,
- 1 status output,
- 1 control input.

The pulse output can also be set as a status output. One of the status outputs can be set as a control input.

4.5.1 Fixed, non-alterable input/output versions

This measuring transducer is available with various input/output combinations.

CG-No.	Connection terminals								
	A+	A	A-	B	B-	C	C-	D	D-

Basic input/output (I/O) standard

1 0 0		$I_p + \text{HART}^{\text{®}}$ passive ①	S_p / C_p passive ②	S_p passive	P_p / S_p passive ②
	$I_a + \text{HART}^{\text{®}}$ active ①				

EEx-i inputs/outputs (I/Os) option

2 0 0				$I_a + \text{HART}^{\text{®}}$ active	P_N / S_N NAMUR ②
3 0 0				$I_p + \text{HART}^{\text{®}}$ passive	P_N / S_N NAMUR ②
2 1 0		I_a active	P_N / S_N NAMUR C_p passive ②	$I_a + \text{HART}^{\text{®}}$ active	P_N / S_N NAMUR ②
3 1 0		I_a active	P_N / S_N NAMUR C_p passive ②	$I_p + \text{HART}^{\text{®}}$ passive	P_N / S_N NAMUR ②
2 2 0		I_p passive	P_N / S_N NAMUR C_p passive ②	$I_a + \text{HART}^{\text{®}}$ active	P_N / S_N NAMUR ②
3 2 0		I_p passive	P_N / S_N NAMUR C_p passive ②	$I_p + \text{HART}^{\text{®}}$ passive	P_N / S_N NAMUR ②

① function changed by reconnection

② changeable

- The grey boxes in the tables denote unassigned or unused connection terminals.
- Connection terminal A+ is only operable in the basic input/output version.

Description of abbreviations and CG identifier for possible optional modules on terminals A and B

Abbreviation	Identifier for CG No.	Description
I _a	A	Active current output (including HART = HART [®] capability)
I _p	B	Passive current output (including HART = HART [®] capability)
P _a / S _a	C	Active pulse, frequency, status output or limit switch (changeable)
P _p / S _p	E	Passive pulse, frequency, status output or limit switch (changeable)
P _N / S _N	F	Passive pulse, frequency, status output or limit switch according to NAMUR (changeable)
C _a	G	Active control input
C _p	K	Passive control input
C _N	H	Active control input to NAMUR Signal converter monitors cable breaks and short circuits as per EN 60947-5-6. Errors indicated on LCD display. Error messages possible via status output.
IIn _a	P	Active current input
IIn _p	R	Passive current input
-	8	No additional module installed
-	0	No further module possible

4.5.2 Basic inputs/outputs



CAUTION!
Observe connection polarity.

Current output active (HART®), basic I/Os

- $U_{\text{int,nom}} = 24 \text{ VDC}$ nominal
- $I \leq 22 \text{ mA}$
- $R_L \leq 1 \text{ k}\Omega$

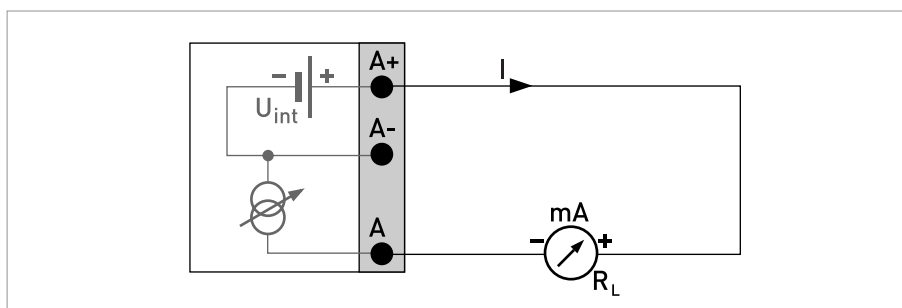
Figure 4-11: Current output active I_a

Current output passive (HART®), basic I/Os

- $U_{\text{int,nom}} = 24 \text{ VDC}$ nominal
- $U_{\text{ext}} \leq 32 \text{ VDC}$
- $I \leq 22 \text{ mA}$
- $U_0 \geq 1.8$
- $R_L \leq (U_{\text{ext}} - U_0) / I_{\text{max}}$

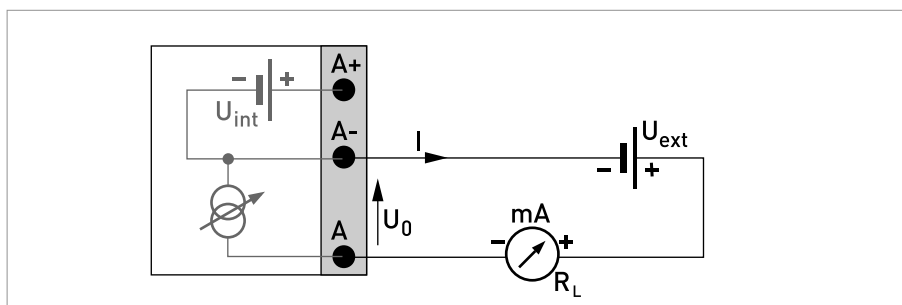
Figure 4-12: Current output passive I_p

**INFORMATION!**

- For frequencies above 100 Hz, shielded cables are to be used in order to reduce radiation from electrical interferences (EMC).
- **Compact and field housing versions:** Shield connected via the cable terminals in the terminal compartment.
- **Wall-mounted version:** Shield connected using 6.3 mm / 0.25" push-on connectors (insulation to DIN 46245) in the terminal compartment.
- Any connection polarity.

Pulse/frequency output passive, basic I/Os

- $U_{\text{ext}} \leq 32 \text{ VDC}$
- f_{max} in operating menu set to $f_{\text{max}} \leq 100 \text{ Hz}$:
 $I \leq 100 \text{ mA}$
 open:
 $I \leq 0.05 \text{ mA}$ at $U_{\text{ext}} = 32 \text{ VDC}$
 closed:
 $U_{0, \text{max}} = 0.2 \text{ V}$ at $I \leq 10 \text{ mA}$
 $U_{0, \text{max}} = 2 \text{ V}$ at $I \leq 100 \text{ mA}$
- f_{max} in the operating menu set to $100 \text{ Hz} < f_{\text{max}} \leq 10 \text{ kHz}$:
 $I \leq 20 \text{ mA}$
 open:
 $I \leq 0.05 \text{ mA}$ at $U_{\text{ext}} = 32 \text{ VDC}$
 closed:
 $U_{0, \text{max}} = 1.5 \text{ V}$ at $I \leq 1 \text{ mA}$
 $U_{0, \text{max}} = 2.5 \text{ V}$ at $I \leq 10 \text{ mA}$
 $U_{0, \text{max}} = 5.0 \text{ V}$ at $I \leq 20 \text{ mA}$
- If the following maximum load resistance $R_{L, \text{max}}$ is exceeded, the load resistance R_L must be reduced accordingly by parallel connection of R :
 $f \leq 100 \text{ Hz}$: $R_{L, \text{max}} = 47 \text{ k}\Omega$
 $f \leq 1 \text{ kHz}$: $R_{L, \text{max}} = 10 \text{ k}\Omega$
 $f \leq 10 \text{ kHz}$: $R_{L, \text{max}} = 1 \text{ k}\Omega$
- The minimum load resistance $R_{L, \text{min}}$ is calculated as follows:
 $R_{L, \text{min}} = (U_{\text{ext}} - U_0) / I_{\text{max}}$
- Can also be set as a status output; for the electrical connection, see status output connection diagram.

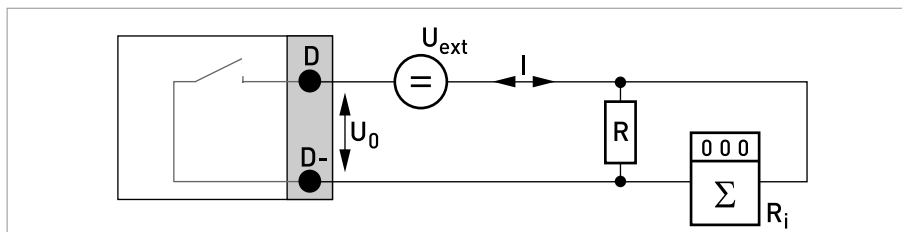
Figure 4-13: Pulse frequency output passive P_p

**INFORMATION!**

- Any connection polarity.

Status output / limit switch passive, basic I/Os

- $U_{\text{ext}} \leq 32 \text{ VDC}$
- $I \leq 100 \text{ mA}$
- $R_{L, \text{max}} = 47 \text{ k}\Omega$
 $R_{L, \text{min}} = (U_{\text{ext}} - U_0) / I_{\text{max}}$
- open:
 $I \leq 0.05 \text{ mA}$ at $U_{\text{ext}} = 32 \text{ VDC}$
 closed:
 $U_{0, \text{max}} = 0.2 \text{ V}$ at $I \leq 10 \text{ mA}$
 $U_{0, \text{max}} = 2 \text{ V}$ at $I \leq 100 \text{ mA}$
- The output is open when the device is de-energized.
- X stands for the terminals B, C or D. The functions of the connection terminals depend on the settings.

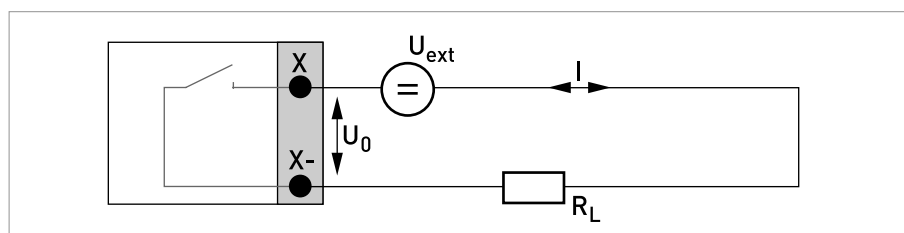
Figure 4-14: Status output / limit switch passive S_p **Control input passive, basic I/Os**

- $8 \text{ V} \leq U_{\text{ext}} \leq 32 \text{ VDC}$
- $I_{\text{max}} = 6.5 \text{ mA}$ at $U_{\text{ext}} \leq 24 \text{ VDC}$
 $I_{\text{max}} = 8.2 \text{ mA}$ at $U_{\text{ext}} \leq 32 \text{ VDC}$
- Set switching point for detection "Contact open or closed":
 Contact open (off): $U_0 \leq 2.5 \text{ V}$ with $I_{\text{nom}} = 0.4 \text{ mA}$
 Contact closed (on): $U_0 \geq 8 \text{ V}$ with $I_{\text{nom}} = 2.8 \text{ mA}$
- Can also be set as a status output; for the electrical connection, see status output connection diagram.

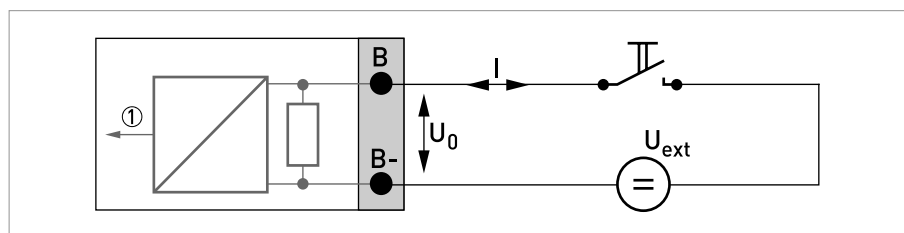
Figure 4-15: Control input passive C_p

- ① Signal

4.5.3 HART[®] connection



INFORMATION!

- In the basic I/O the current output at connection terminals A+/A-/A always has HART[®] capability.
- For modular I/O, only the current output module for the connection terminals has C/C-HART[®] capability.

HART[®] connection active (point-to-point)

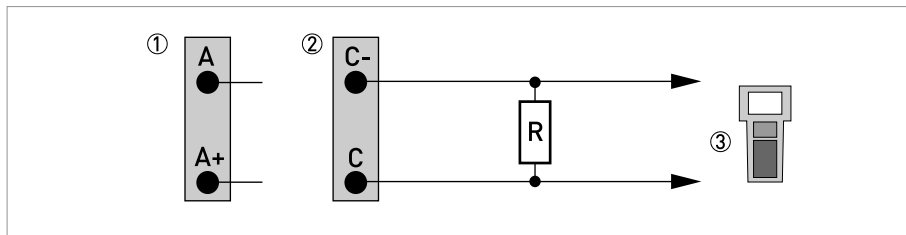

Figure 4-16: HART[®] connection active (I_a)

- ① Basic I/O: terminals A and A+
- ② Modular I/O: terminals C- and C
- ③ HART[®] communicator

The parallel resistance to the HART[®] communicator must be $R \geq 230 \Omega$.

HART® connection passive (multidrop mode)

- $I: I_{0\%} \geq 4 \text{ mA}$
- Multidrop mode I: $I_{\text{fix}} \geq 4 \text{ mA} = I_{0\%}$
- $U_{\text{ext}} \leq 32 \text{ VDC}$
- $R \geq 230 \Omega$

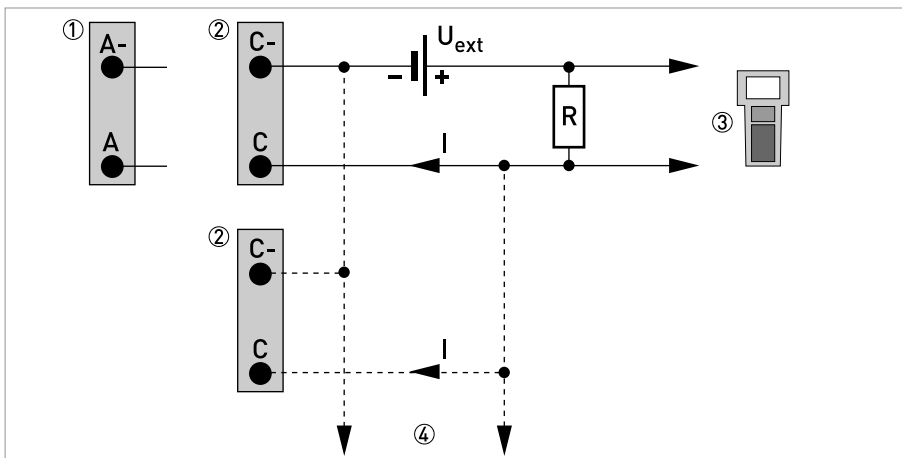

Figure 4-17: HART® connection passive (I_p)

- ① Basic I/O: terminals A- and A
- ② Modular I/O: terminals C- and C
- ③ HART® communicator
- ④ Other HART®-capable devices

4.6 Modular Inputs and Outputs



INFORMATION!

In the following connection diagrams, the terminals A, B, C or D (depending on the version of the UFC 300) are marked with a "X".

4.6.1 Alterable input/output versions

The signal converter is available with various input/output combinations.

CG-No.	Connection terminals							
	A+	A	A-	B	B-	C	C-	D

Modular inputs/outputs option

4 __		max. 2 option modules for term. A + B	$I_a + \text{HART}^\circledast$ active	P_a / S_a active ①
8 __		max. 2 option modules for term. A + B	$I_p + \text{HART}^\circledast$ passive	P_a / S_a active ①
6 __		max. 2 option modules for term. A + B	$I_a + \text{HART}^\circledast$ active	P_p / S_p passive ①
B __		max. 2 option modules for term. A + B	$I_p + \text{HART}^\circledast$ passive	P_p / S_p passive ①
7 __		max. 2 option modules for term. A + B	$I_a + \text{HART}^\circledast$ active	P_N / S_N NAMUR ①

CG-No.	Connection terminals								
	A+	A	A-	B	B-	C	C-	D	D-
C _ _		max. 2 option modules for term. A + B				I _p + HART [®] passive		P _N / S _N NAMUR ①	

① changeable

Description of abbreviations and CG identifier for possible optional modules on terminals A and B

Abbreviation	Identifier for CG No.	Description
I _a	A	Active current output (including HART = HART [®] capability)
I _p	B	Passive current output (including HART = HART [®] capability)
P _a / S _a	C	Active pulse, frequency, status output or limit switch (changeable)
P _p / S _p	E	Passive pulse, frequency, status output or limit switch (changeable)
P _N / S _N	F	Passive pulse, frequency, status output or limit switch according to NAMUR (changeable)
C _a	G	Active control input
C _p	K	Passive control input
C _N	H	Active control input to NAMUR Signal converter monitors cable breaks and short circuits as per EN 60947-5-6. Errors indicated on LCD display. Error messages possible via status output.
II _{n_a}	P	Active current input
II _{n_p}	R	Passive current input
-	8	No additional module installed
-	0	No further module possible

4.6.2 Modular inputs/outputs and bus systems



CAUTION!
Observe connection polarity.



INFORMATION!

- For the electrical connection of the bus systems, please refer to the separate documentation for the respective bus systems.

Current output active (only current output terminals C/C- have HART[®] capability), modular I/Os

- $U_{\text{int, nom}} = 24 \text{ VDC}$
- $I \leq 22 \text{ mA}$
- $R_L \leq 1 \text{ k}\Omega$
- X designates the connection terminals A, B or C, depending on the version of the signal converter.

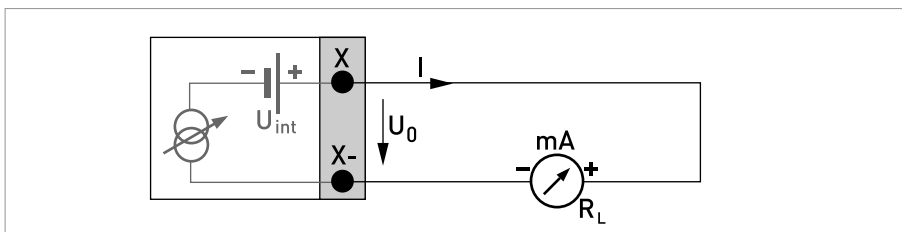

Figure 4-18: Current output active I_a

Current output passive (only current output terminals C/C- have HART[®] capability), modular I/Os

- $U_{\text{ext}} \leq 32 \text{ VDC}$
- $I \leq 22 \text{ mA}$
- $U_0 \geq 1.8 \text{ V}$
- $R_L \leq (U_{\text{ext}} - U_0) / I_{\text{max}}$
- X designates the connection terminals A, B or C, depending on the version of the signal converter.

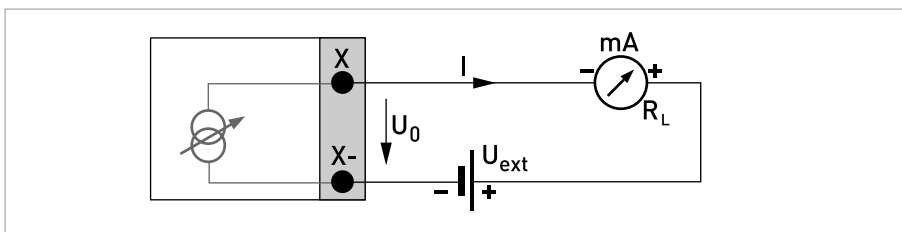

Figure 4-19: Current output passive I_p

**INFORMATION!**

- For frequencies above 100 Hz, shielded cables are to be used in order to reduce radiation from electrical interferences (EMC).
- **Compact and field housing versions:** Shield connected via the cable terminals in the terminal compartment.
- **Wall-mounted version:** Shield connected using 6.3 mm / 0.25" push-on connectors (insulation to DIN 46245) in the terminal compartment.
- Any connection polarity.

Pulse/frequency output active, modular I/Os

- $U_{nom} = 24$ VDC
- f_{max} in operating menu set to $f_{max} \leq 100$ Hz:
 $I \leq 20$ mA
 open:
 $I \leq 0.05$ mA
 closed:
 $U_{0,nom} = 24$ V at $I = 20$ mA
- f_{max} in the operating menu set to 100 Hz $< f_{max} \leq 10$ kHz:
 $I \leq 20$ mA
 open:
 $I \leq 0.05$ mA
 closed:
 $U_{0,nom} = 22.5$ V at $I = 1$ mA
 $U_{0,nom} = 21.5$ V at $I = 10$ mA
 $U_{0,nom} = 19$ V at $I = 20$ mA
- If the following maximum load resistance $R_{L,max}$ is exceeded, the load resistance R_L must be reduced accordingly by parallel connection of R:
 $f \leq 100$ Hz: $R_{L,max} = 47$ k Ω
 $f \leq 1$ kHz: $R_{L,max} = 10$ k Ω
 $f \leq 10$ kHz: $R_{L,max} = 1$ k Ω
- The minimum load resistance $R_{L,min}$ is calculated as follows:
 $R_{L,min} = (U_{ext} - U_0) / I_{max}$
- X designates the connection terminals A, B or D, depending on the version of the signal converter.

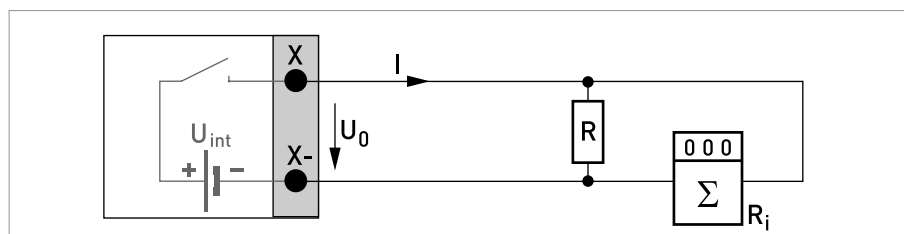
Figure 4-20: Pulse / frequency output active P_a

**INFORMATION!**

For frequencies above 100 Hz, shielded cables are to be used in order to reduce radiation from electrical interferences (EMC).

Pulse/frequency output passive, modular I/Os

- $U_{\text{ext}} \leq 32 \text{ VDC}$
- f_{max} in the operating menu set to $f_{\text{max}} \leq 100 \text{ Hz}$:
 $I \leq 100 \text{ mA}$
 open:
 $I \leq 0.05 \text{ mA}$ at $U_{\text{ext}} = 32 \text{ VDC}$
 closed:
 $U_{0, \text{max}} = 0.2 \text{ V}$ at $I \leq 10 \text{ mA}$
 $U_{0, \text{max}} = 2 \text{ V}$ at $I \leq 100 \text{ mA}$
- f_{max} in the operating menu set to $100 \text{ Hz} < f_{\text{max}} \leq 10 \text{ kHz}$:
 open:
 $I \leq 0.05 \text{ mA}$ at $U_{\text{ext}} = 32 \text{ VDC}$
 closed:
 $U_{0, \text{max}} = 1.5 \text{ V}$ at $I \leq 1 \text{ mA}$
 $U_{0, \text{max}} = 2.5 \text{ V}$ at $I \leq 10 \text{ mA}$
 $U_{0, \text{max}} = 5 \text{ V}$ at $I \leq 20 \text{ mA}$
- If the following maximum load resistance $R_{L, \text{max}}$ is exceeded, the load resistance R_L must be reduced accordingly by parallel connection of R :
 $f \leq 100 \text{ Hz}$: $R_{L, \text{max}} = 47 \text{ k}\Omega$
 $f \leq 1 \text{ kHz}$: $R_{L, \text{max}} = 10 \text{ k}\Omega$
 $f \leq 10 \text{ kHz}$: $R_{L, \text{max}} = 1 \text{ k}\Omega$
- The minimum load resistance $R_{L, \text{min}}$ is calculated as follows:
 $R_{L, \text{min}} = (U_{\text{ext}} - U_0) / I_{\text{max}}$
- Can also be set as a status output; see status output connection diagram.
- X designates the connection terminals A, B or D, depending on the version of the signal converter.

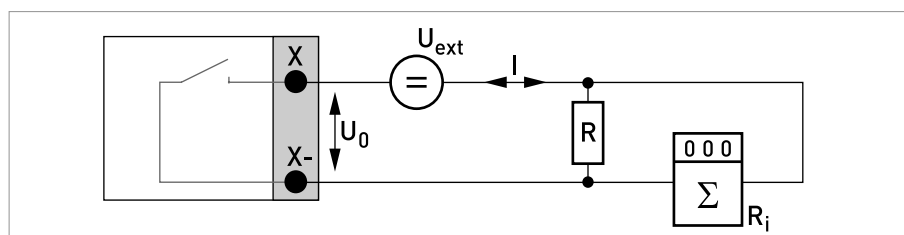

Figure 4-21: Pulse frequency output passive P_p

**INFORMATION!**

- For frequencies above 100 Hz, shielded cables are to be used in order to reduce radiation from electrical interferences (EMC).
- **Compact and field housing versions:** Shield connected via the cable terminals in the terminal compartment.
- **Wall-mounted version:** Shield connected using 6.3 mm / 0.25" push-on connectors (insulation to DIN 46245) in the terminal compartment.
- Any connection polarity.

Pulse and frequency output passive P_N NAMUR, modular I/O

- Connection in conformity with EN 60947-5-6
- open:
 $I_{nom} = 0.6 \text{ mA}$
- closed:
 $I_{nom} = 3.8 \text{ mA}$
- X designates the connection terminals A, B or D, depending on the version of the signal converter.

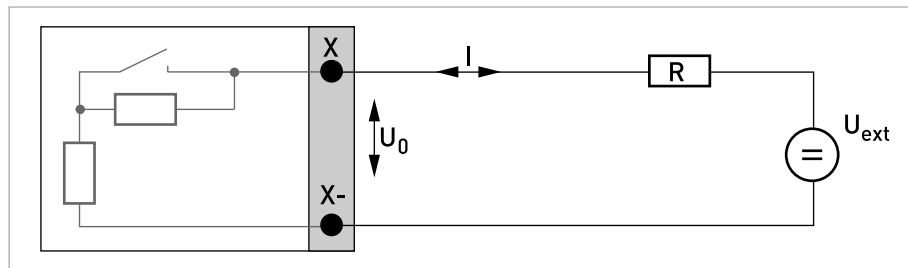
Figure 4-22: Pulse and frequency output passive P_N to NAMUR EN 60947-5-6

Status output / limit switch active, modular I/Os

- Observe connection polarity.
- $U_{\text{int}} = 24 \text{ VDC}$
- $I \leq 20 \text{ mA}$
- $R_L \leq 47 \text{ k}\Omega$
- open:
 $I \leq 0.05 \text{ mA}$
- closed:
 $U_{0, \text{nom}} = 24 \text{ V}$ at $I = 20 \text{ mA}$
- X designates the connection terminals A, B or D, depending on the version of the signal converter.

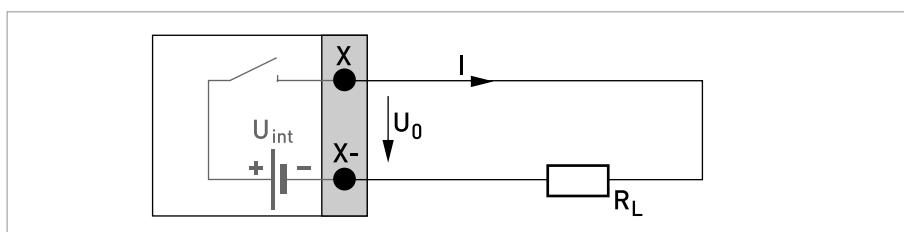
Figure 4-23: Status output / limit switch active S_a **Status output / limit switch passive, modular I/Os**

- Any connection polarity.
- $U_{\text{ext}} = 32 \text{ VDC}$
- $I \leq 100 \text{ mA}$
- $R_{L, \text{max}} = 47 \text{ k}\Omega$
 $R_{L, \text{min}} = (U_{\text{ext}} - U_0) / I_{\text{max}}$
- open:
 $I \leq 0.05 \text{ mA}$ at $U_{\text{ext}} = 32 \text{ VDC}$
- closed:
 $U_{0, \text{max}} = 0.2 \text{ V}$ at $I \leq 10 \text{ mA}$
 $U_{0, \text{max}} = 2 \text{ V}$ at $I \leq 100 \text{ mA}$
- The output is open when the device is de-energized.
- X designates the connection terminals A, B or D, depending on the version of the signal converter.

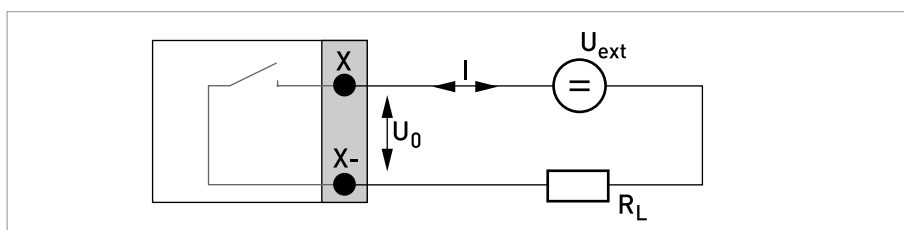
Figure 4-24: Status output / limit switch passive S_p

Status output / limit switch S_N NAMUR, modular I/Os

- Any connection polarity.
- Connection in conformity with EN 60947-5-6
- open:
 $I_{nom} = 0.6 \text{ mA}$
- closed:
 $I_{nom} = 3.8 \text{ mA}$
- The output is open when the device is de-energized.
- X designates the connection terminals A, B or D, depending on the version of the signal converter.

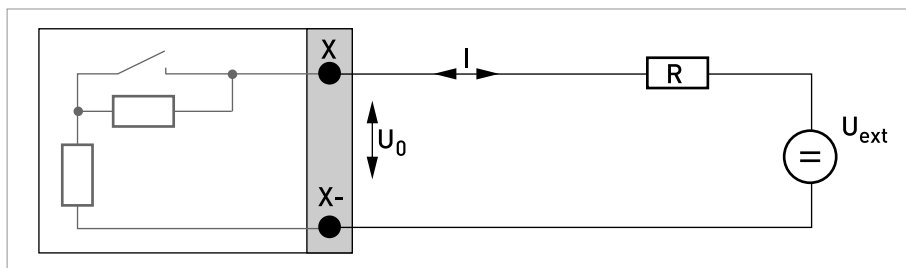

Figure 4-25: Status output / limit switch S_N to NAMUR EN 60947-5-6

**CAUTION!**

Observe connection polarity.

Control input active, modular I/Os

- $U_{\text{int}} = 24 \text{ VDC}$
- External contact open:
 $U_{0,\text{nom}} = 22 \text{ V}$
- External contact closed:
 $I_{\text{nom}} = 4 \text{ mA}$
- Set switching point for detection "Contact open or closed:
Contact open (off): $U_0 \leq 10 \text{ V}$ with $I_{\text{nom}} = 1.9 \text{ mA}$
Contact closed (on): $U_0 \geq 12 \text{ V}$ with $I_{\text{nom}} = 1.9 \text{ mA}$
- X designates the connection terminals A or B, depending on the version of the signal converter.

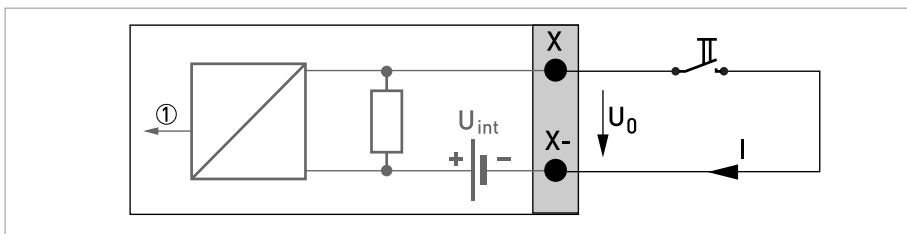

Figure 4-26: Control input active C_a

① Signal

Control input passive, modular I/Os

- $3 \text{ V} \leq U_{\text{ext}} \leq 32 \text{ VDC}$
- $I_{\text{max}} = 9.5 \text{ mA}$ at $U_{\text{ext}} \leq 24 \text{ V}$
 $I_{\text{max}} = 9.5 \text{ mA}$ at $U_{\text{ext}} \leq 32 \text{ V}$
- Set switching point for detection "Contact open or closed:
Contact open (off): $U_0 \leq 2.5 \text{ V}$ with $I_{\text{nom}} = 1.9 \text{ mA}$
Contact closed (on): $U_0 \geq 3 \text{ V}$ with $I_{\text{nom}} = 1.9 \text{ mA}$
- X designates the connection terminals A or B, depending on the version of the signal converter.

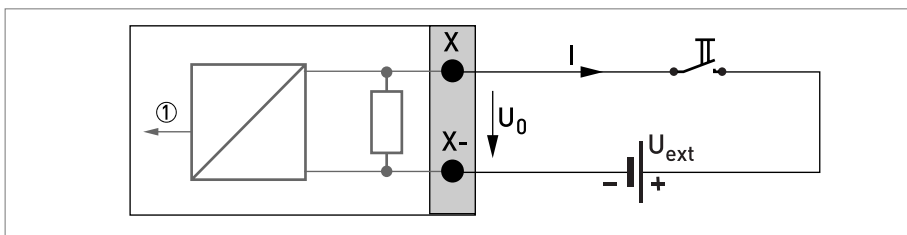

Figure 4-27: Control input passive C_p

① Signal



CAUTION!
Observe connection polarity.

Control input active C_N NAMUR, modular I/Os

- Connection in conformity with EN 60947-5-6
- Set switching point for detection "Contact open or closed":
Contact open (off): $U_{0, nom} = 6.3 \text{ V}$ with $I_{nom} < 1.9 \text{ mA}$
Contact closed (on): $U_{0, nom} = 6.3 \text{ V}$ with $I_{nom} > 1.9 \text{ mA}$
- Detection of cable break:
 $U_0 \geq 8.1 \text{ V}$ with $I \leq 0.1 \text{ mA}$
- Detection of cable short circuit:
 $U_0 \leq 1.2 \text{ V}$ with $I \geq 6.7 \text{ mA}$
- X designates the connection terminals A or B, depending on the version of the signal converter.

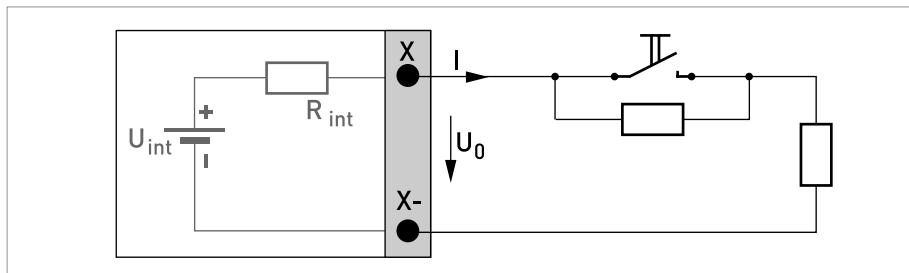
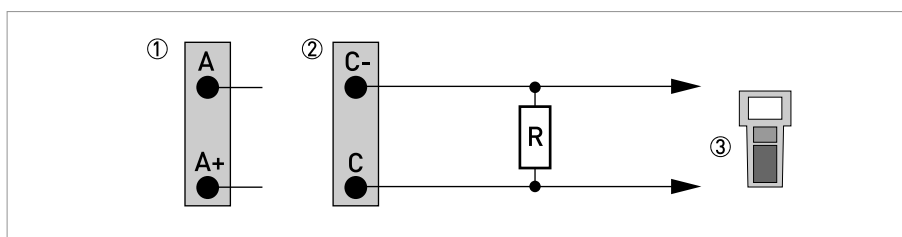

Figure 4-28: Control input active C_N to NAMUR EN 60947-5-6

4.6.3 HART[®] connection**INFORMATION!**

- In the basic I/O the current output at connection terminals A+/A-/A always has HART[®] capability.
- For modular I/O, only the current output module for the connection terminals has C/C-HART[®] capability.

HART[®] connection active (point-to-point)Figure 4-29: HART[®] connection active (I_a)

- ① Basic I/O: terminals A and A+
- ② Modular I/O: terminals C- and C
- ③ HART[®] communicator

The parallel resistance to the HART[®] communicator must be $R \geq 230 \Omega$.

HART[®] connection passive (multidrop mode)

- $I: I_{0\%} \geq 4 \text{ mA}$
- Multidrop mode I: $I_{\text{fix}} \geq 4 \text{ mA} = I_{0\%}$
- $U_{\text{ext}} \leq 32 \text{ VDC}$
- $R \geq 230 \ \Omega$

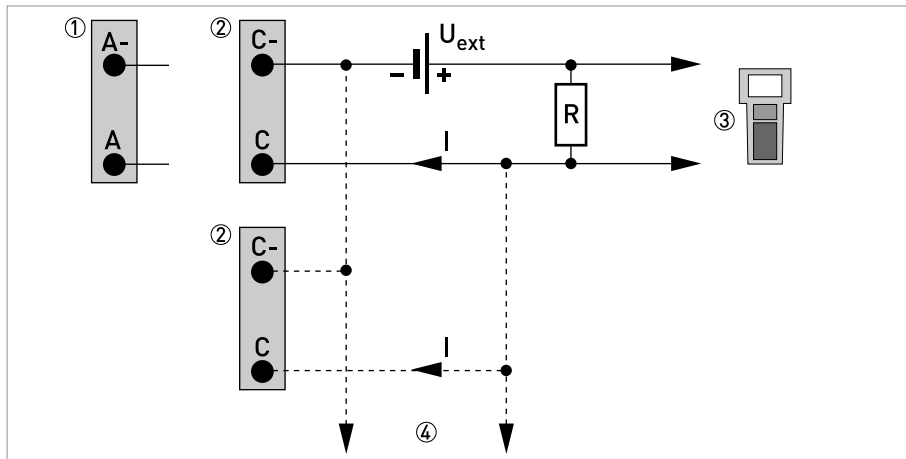

Figure 4-30: HART[®] connection passive (I_p)

- ① Basic I/O: terminals A- and A
- ② Modular I/O: terminals C- and C
- ③ HART[®] communicator
- ④ Other HART[®]-capable devices

5.1 General instructions for programming

Human machine interface (HMI)

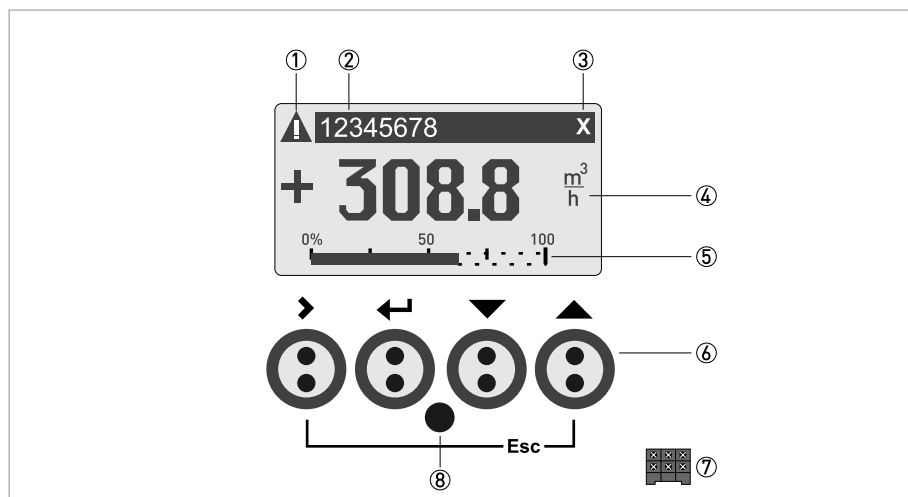

Figure 5-1: Display and operating elements (Example: flow indication with 2 measuring values)

- ① Indicates a possible status message in the status list
- ② Tag number (is only indicated if this number was entered previously by the operator)
- ③ Indicates when a key has been pressed
- ④ 1st measured variable in large depiction
- ⑤ Bargraph indication
- ⑥ Keys (see table below for function and depiction in text)
- ⑦ Interface to the GDC bus (not present in all signal converter versions)
- ⑧ Infrared sensor (not present in all signal converter versions)

Key	Measuring mode	Menu mode	Sub-menu or function mode	Parameter and data mode
>	Switch from measuring mode to menu mode; press key for 2.5 s, "quick start" menu is then displayed	Access to displayed menu, then 1st submenu is displayed	Access to displayed sub-menu or function	For numerical values, move cursor (highlighted in blue) one position to the right
←	-	Return to measuring mode but first ask whether the data should be saved	Press 1 to 3 times, return to menu mode, data saved	Return to sub-menu or function, data saved
↓ or ↑	Switch between display pages: measured value 1 + 2, trend page and status page(s)	Select menu	Select sub-menu or function	Use cursor highlighted in blue to change number, unit, setting and to move the decimal point
Esc (> + ↑)	-	-	Return to menu mode without acceptance of data	Return to sub-menu or function without acceptance of data

Table 5-1: Description of key functionality

Start installation menu



- Connect converter to power supply and power up converter.

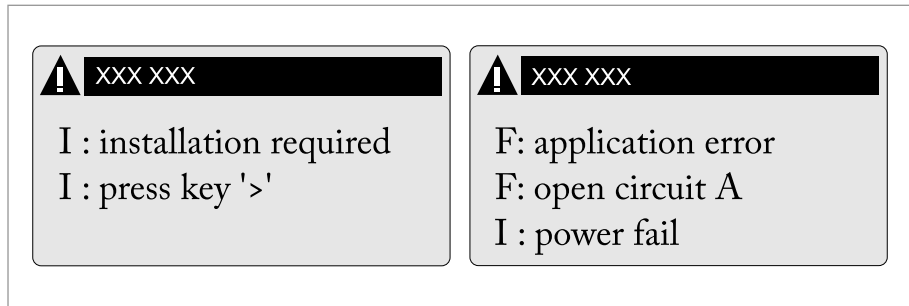

First and second page appear intermittently



- Keep left button ">" pressed, until in display appears "release key now".

Installation menu

**CAUTION!**

- If you program the diameter, use the outer diameter of the pipe.
- For improved accuracy fill in as much details as possible.
- Fill in the actual transducer distance at menu X9.7
- Run the optimization loop until the transducer distance changes no more than 0.5%.



- > ↓ ↑ ↵

X1...X7

X1	language	>	select from list using ↑ ↓ >		↵
X2	GDC IR interface	>	activate / cancel		↵
X3	units	>	X3.1, X3.2, ...	↑ ↓	
	X3.1	size	>	select from list using ↑ ↓ >	↵
	X3.2	volume flow	>	select from list using ↑ ↓ >	↵
	X3.3	velocity	>	select from list using ↑ ↓ >	↵
	X3.4	density	>	select from list using ↑ ↓ >	↵
	X3.5	viscosity	>	select from list using ↑ ↓ >	↵
X4	number of pipes	>	1 pipe / 2 pipes	↑ ↓	↵
[X5 becomes active if one pipe is selected in X4]					
X5	number of paths	>	1 path / 2 paths	↑ ↓	↵
[underneath X6 becomes active if one pipe is selected in X4]					
[Note: the measurement results of path 1 and path 2 are averaged !]					
[underneath X6 and X7 become active if two pipes are selected in X4]					
X6	pipe data / pipe data 1	>	X6.2, X6.3, ...	↑ ↓	
	X6.2	pipe tag	>	fill in 12 pos using ↑ ↓ >	↵
	X6.3	diameter	>	fill in using ↑ ↓ >	↵
	X6.4	pipe material	>	select from list using ↑ ↓ >	↵
	X6.5	VoS pipe material	>	read advise or fill in using ↑ ↓ >	↵
	X6.6	wall thickness	>	fill in using ↑ ↓ >	↵
	X6.7	liner material	>	select from list using ↑ ↓ >	↵
	X6.8	VoS liner material	>	read advise or fill in using ↑ ↓ >	↵
	X6.9	liner thickness	>	fill in using ↑ ↓ >	↵
	X6.10	fluid	>	select from list using ↑ ↓ >	↵
	X6.11	VoS fluid	>	read advise or fill in using ↑ ↓ >	↵
	X6.12	density	>	read advise or fill in using ↑ ↓ >	↵
	X6.13	viscosity	>	fill in using ↑ ↓ >	↵
X7	pipe data 2	>		↑ ↓	
	X7.1	copy pipe 1 data	>	start to copy ?	↑ ↓

				if no:	copy pipe 1 data appears Go to X7 Fill in menu X7.2 up to X7.13: is similar to X6.2 up to X6.13	←
				if yes:	copy pipe 1 data appears after copy process	←

X9...X10

X9	install transd. 1	>	X9.1, X9.2,...	↑ ↓	
	X9.1	transducer set	>	read preset Ta,Tb,Tc / confirm or overrule using ↑ ↓ >	
	X9.2	calibration number		read	←
	X9.3	number of traverses	>	read preset 1,2,4 / confirm or overrule using ↑ ↓ >	
	X9.4	mount transducers at		read advise	←
	please wait: decoupling 30 seconds				
	X9.5	act. flow, preliminary		read	←
	X9.6	check signal		read (0 - 100 %)	←
	X9.7	actual distance	>	fill in using ↑ ↓ >	←
	[start optimization loop]				
	X9.8.1	optimize distance ?		yes/no	←
				if no:	go to X9.9
				if yes:	continue with X9.8.2
	X9.8.2	act. VoS fluid		read	←
	X9.8.3	continue ?		yes/no	←
				if no:	go to X9.9
				if yes:	continue with X9.8.4
	X9.8.4	VoS fluid		read / confirm or overrule using ↑ ↓ >	←
	X9.8.5	mount transducers at		read advise	←
	[end optimization loop; next menu appearing is X9.8.1]				
	(underneath X10 becomes active if two pipes or two paths are selected in X4 or X5)				
X10	install transd. 2	>		↑ ↓	
				submenus identical to X9.1 up to X9.12	
					←

5.2 Start measurement of small / medium version



- Power up the converter (do not mount and/or connect the rails yet)
- Fill in menu X1...X7 (see section "Installation menu" in chapter "General instructions for programming")
- X9.1: Check the reading with the sensor code (Ta/Tb) on rail. Press enter
- X9.2: Check the reading with the calibration number on the nameplate. Press enter
- X9.3: Check the factory preset number of traverses (default: 2, for DN<25: 4)
- X9.4: Read the advised mounting distance and position the transducer at that distance . Press enter
- X9.5: Read the preliminary volume flow. Press enter
- X9.6: Read the actual signal strength

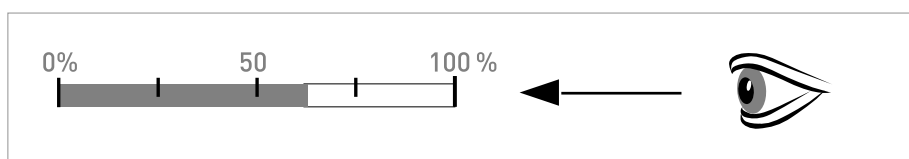

INFORMATION!

Advice on signal strength:

Signal > 75%: good signal, optimization loop not needed

Signal 50...75%: fairly good signal, optimization loop can improve the signal

Signal 10...50%: low signal, optimization loop needed

Signal < 10%: bad or no signal, check settings in menu X6, increase transducer distance and/or go into the optimization loop.



- X9.7: Confirm or adjust the reading with the actual distance on the rail.
- X9.8: Optimization loop. Repeat steps X9.8.1...X9.8.5 until the advised mounting distance does not change more than 0.5%.
 - X9.8.1: Optimise distance?
 - X9.8.2: Read the velocity of sound of the fluid
 - X9.8.3: Continue?
 - X9.8.4: Confirm or adjust the velocity of sound
 - X9.8.5: Read the advised mounting distance and reposition the transducer
- X9.9: Read the preliminary volume flow
- X9.10: Path ready? Enter "Yes". If you have:
 - 1 path or pipe: you are finished, proceed with X9.12
 - 2 paths: go to X9 for the 2nd path
 - 2 pipes: go to X10 for the 2nd pipe
- X9.12: End Installation? Enter "Yes" to save the installation. The measurement screen will appear.
- Mount the cover (see the section "mounting the cover" in chapter "General mechanical installation")

5.3 Start measurement of large version

Prepare installation

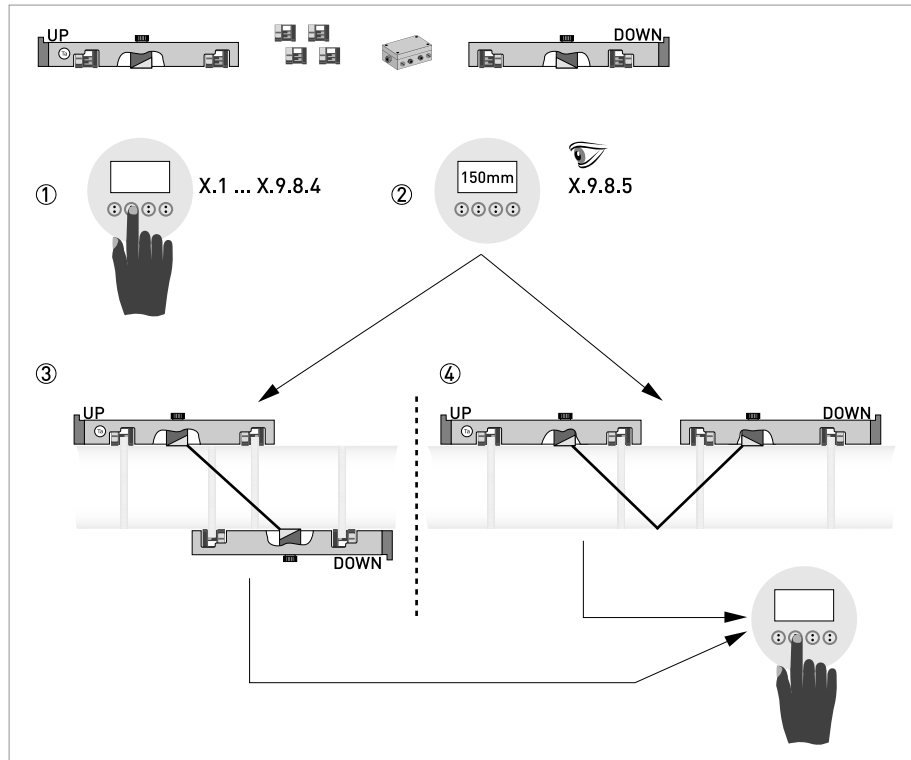

Figure 5-2: Procedure for installation of large version

- ① Enter the values for the installation menu, X1...X9.8.4
- ② Read the advised mounting distance in menu X9.8.5
- ③ Choose for Z-mode (default) or ...
- ④ Choose for V-mode
- ⑤ Finish the installation menu



- Power up the converter (do not mount and/or connect the rails yet)
- Fill in menu X1...X7 as described in section "Installation menu" in chapter "General instructions for programming". Select "1 path" initially in X5
- X9.1: Check the reading with the sensor code (Ta/Tb) on rail
- X9.2: Check the reading with the calibration number on the nameplate
- X9.3: Check the factory preset number of traverses (default: 1 for Z-mode)
- X9.4: Read the advised mounting distance. Write it down, you need it later
- X9.5: Press enter
- X9.6: Press enter. Wait for 30 seconds
- X9.7: Press enter
- X9.8: Optimization loop. Enter "No" in X9.8.1
- X9.9: Press enter. Wait for 30 seconds
- X9.10: Path ready? Enter "Yes"
- X9.12: End Installation? Enter "Yes"

**CAUTION!**

Choose between Z and V mode before you proceed. The Advised Distance (menu X9.4) must be > 246 mm / 9,7" for V-mode.

Set transducer positions for both rails according to the table below.

Advised distance [mm]	Transducer position [mm]
100...250	-65
>250	0

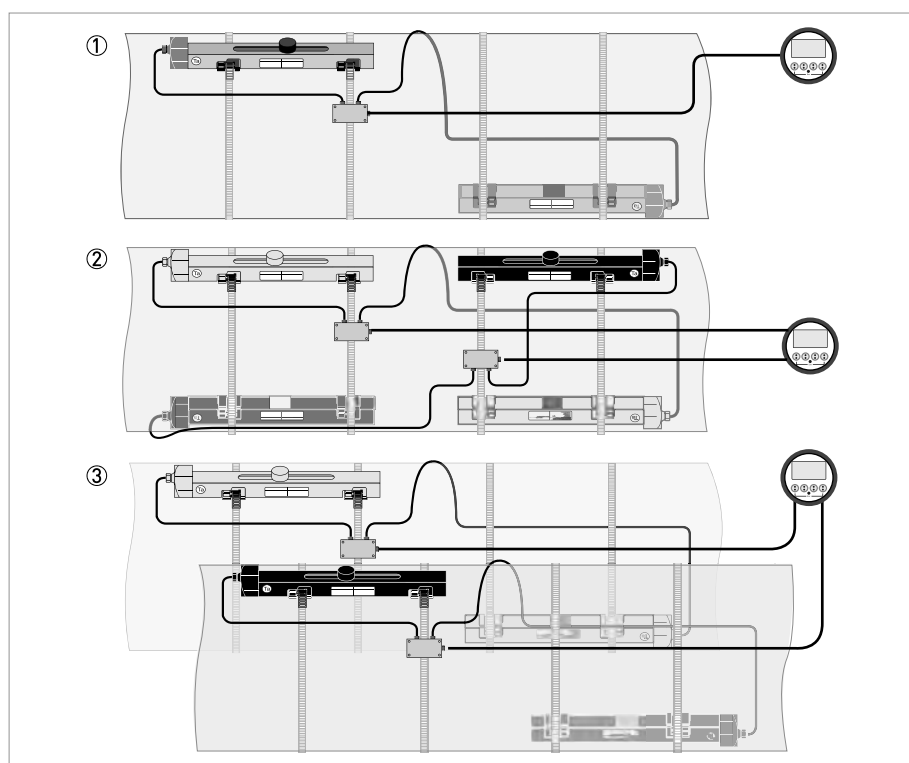

Figure 5-3: Device versions

- ① Single pipe, single path
- ② Single pipe, dual path
- ③ Dual pipe

5.4 Mechanical installation for large version



INFORMATION!

You need a calculator, measuring band and pen & paper to install a large version.

Mounting the UP rail



CAUTION!

Make sure that you mount the rail parallel to the pipe. Mount the fixing units and the cable box as shown below.

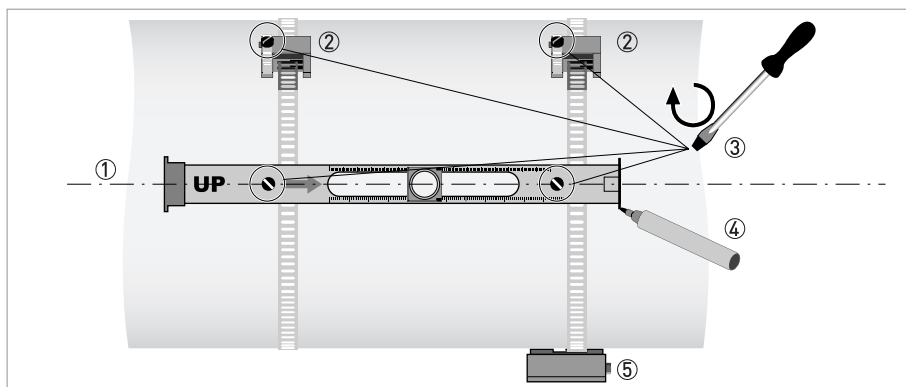

Figure 5-4: Mounting the large rail

- ① Align the UP rail with the pipeline.
- ② Fixing units
- ③ Turn screws clockwise to secure.
- ④ Mark the position.
- ⑤ Cable box

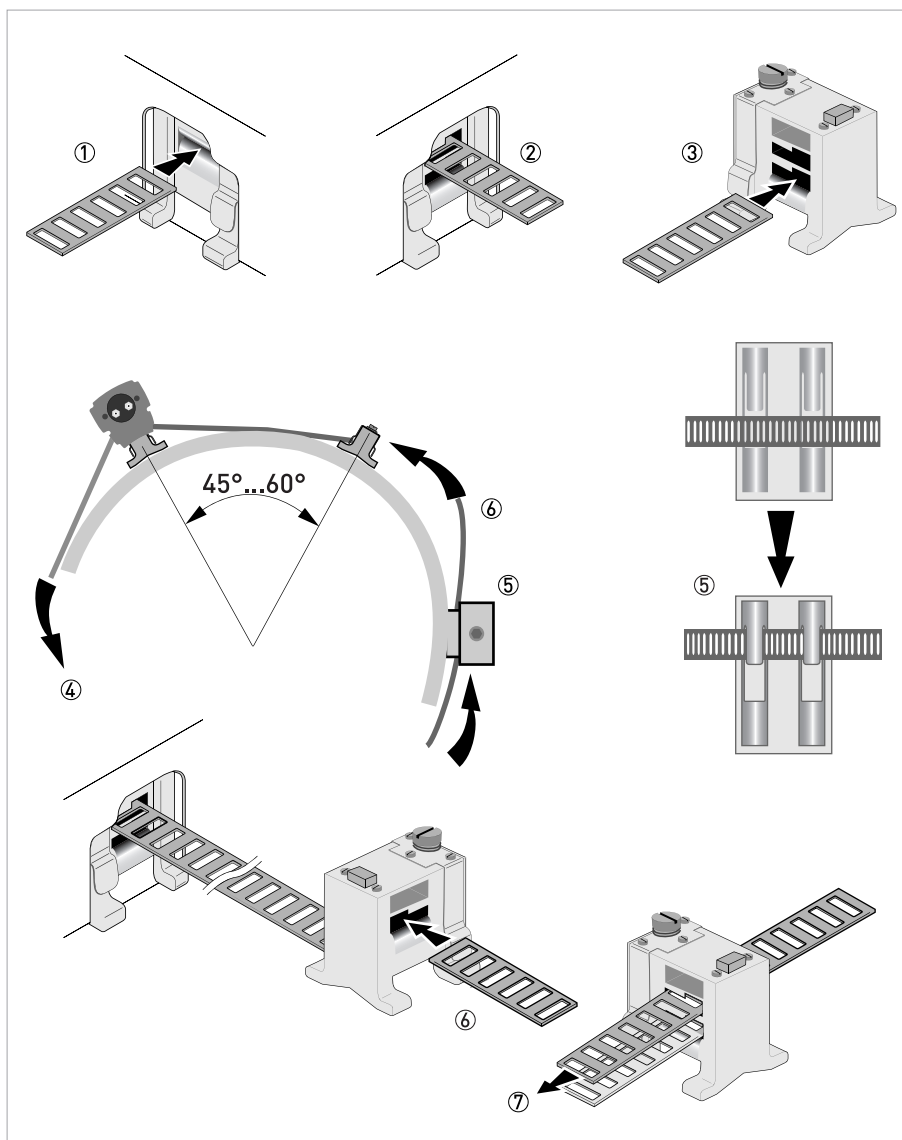

Figure 5-5: Mounting large version rail

- ① Pull the metal strap through the upper slit of the UP rail.
- ② Take the metal strap around the pipe (45...60°).
- ③ Push the end of the metal strap in the lower slit of the fixing unit.
- ④ Take the other side of the metal strap around the pipe to the fixing unit.
- ⑤ Mount the cable box (only for downstream metal strap).
- ⑥ Push the metal strap through the upper slit of the fixing unit.
- ⑦ Pull the metal strap moderately tight by hand.



- Secure by turning screws clockwise.

Mounting the DOWN rail in Z-mode

Set transducer positions for both rails according to the table below.

Advised distance [mm]	Transducer position [mm]
100...250	-65
>250	0

Measure the outer diameter of the pipe with a measuring band.

For Z-mode, you must install the DOWN rail at the opposite location at the pipe. There are two possible ways to find the exact location:

1. FIND THE LOCATION WITH A FIXED REFERENCE POINT

Calculate the half of the outer diameter. Mark this 180° alignment line on the pipe.

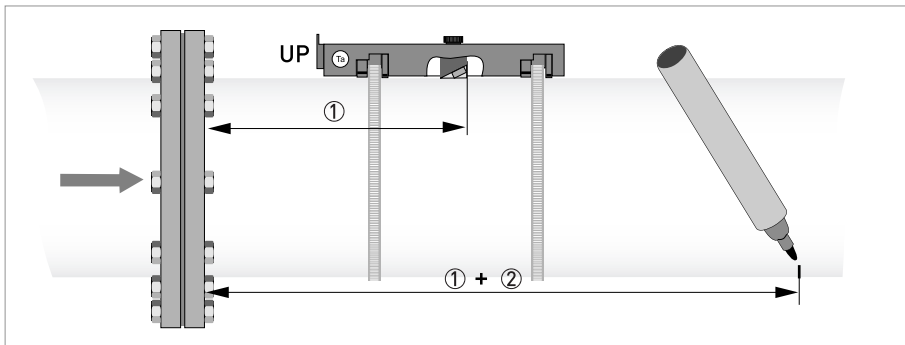
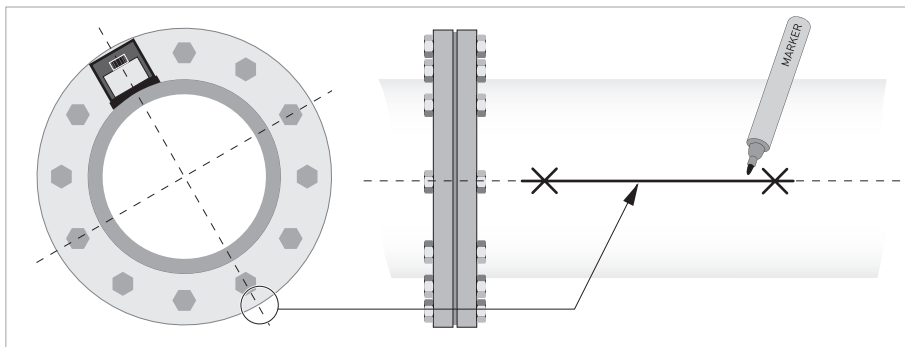

Figure 5-6: Find the opposite location with a reference point

- ① Measure the distance between the transducer of the UP rail and the reference point.
- ② Add the Advised Distance and mark the location on the alignment line.



- Mount the DOWN rail in such a way that the transducer is at the marked location.

2. FIND THE LOCATION WITH THE SUPPLIED POSITIONING TOOL

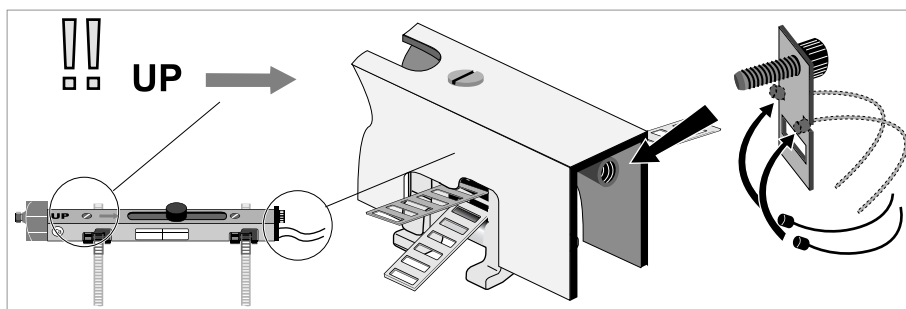

Mount the positioning tool to the UP rail as shown.

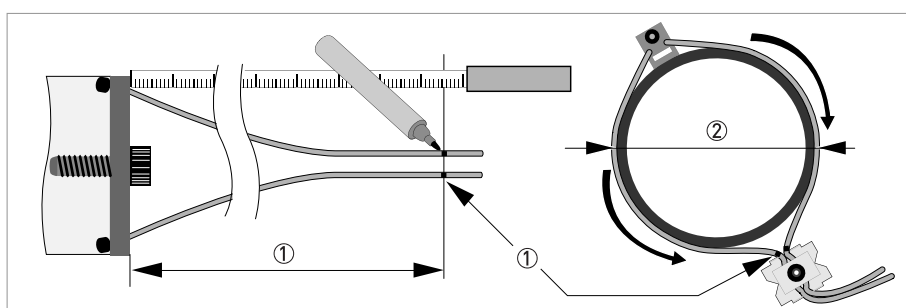

- ① Mark the cables at a distance of 1.63 x outer diameter.
- ② Outer diameter of pipeline



INFORMATION!

For large diameters you can use the weight of the metal plates to throw the cable around the pipe. First release one of the cables in that case!

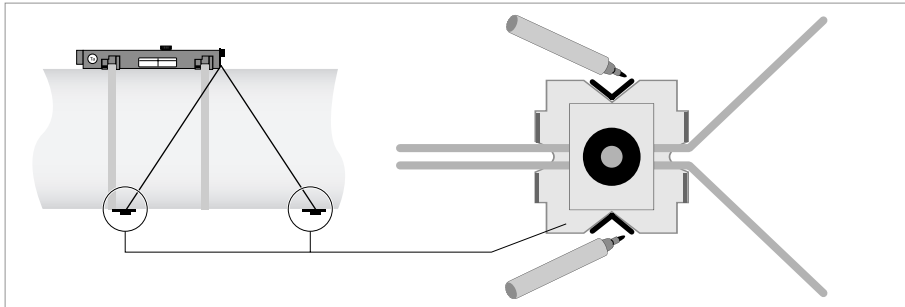

Figure 5-7: Mark the pipelines with the V-mark

Pull the V-shaped plate in the downstream direction as much as possible. Pay attention that the cables are not obstructed. Put the two V-marks on the pipeline.

Do the same in the upstream direction.



CAUTION!

Repeat above steps to check if you find the same points.

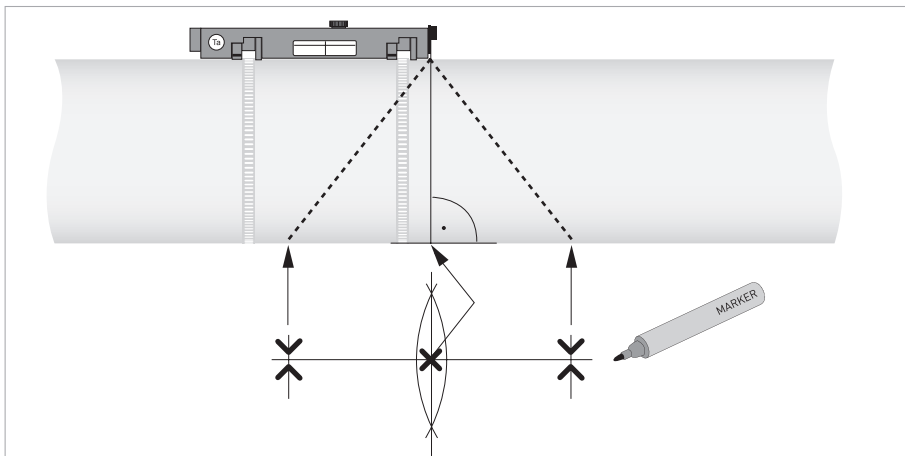

Figure 5-8: Marking the opposite location

Calculate the middle of the alignment line between the 4 V-marks as shown.

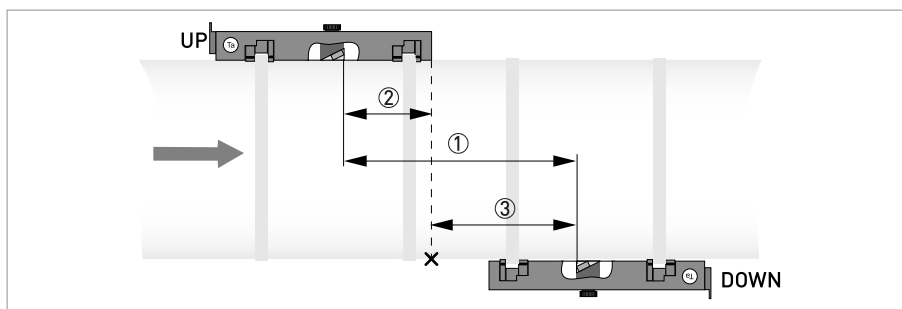

Figure 5-9: Finding the location for the DOWN rail

- ① Advised Distance as shown in menu X9.4
- ② Measure the distance between the transducer and the end of the UP rail.
- ③ Determine and mark the location of the transducer of the DOWN rail: $③ = ① - ②$



- Mount the DOWN rail in such a way that the transducer is at the marked location.
- Grease all transducers, see "General mechanical installation".



INFORMATION!

It can be necessary to install the DOWN rail as shown below.

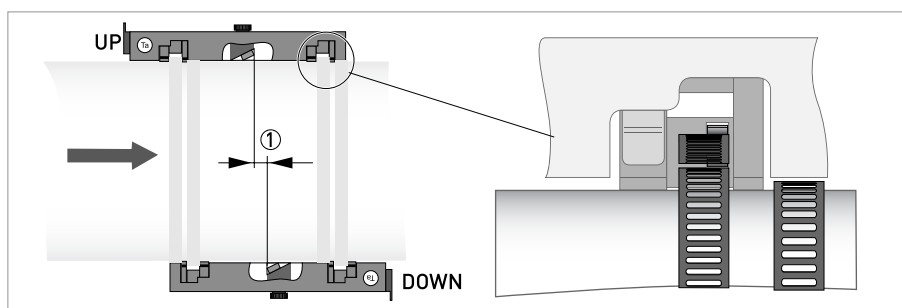

Mounting the DOWN rail in V-mode

For V-mode, you must install the DOWN rail in line with the UP rail. It is easier to install than the Z-mode, but you need more free pipe length. V-mode is possible for DN450/600...2000 (minimum depends on application).

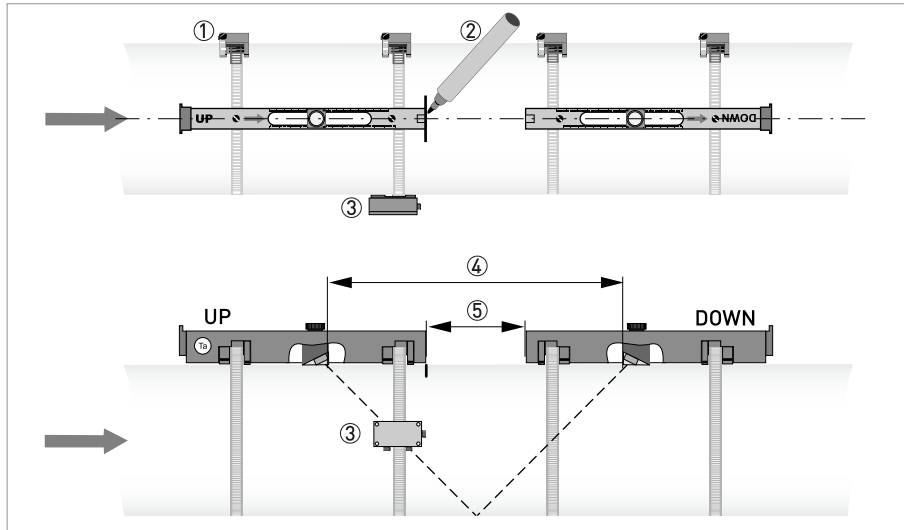

Figure 5-10: Mounting large version in V-mode

- ① Fixing units
- ② Reference marking
- ③ Cable box
- ④ Advised Distance, X9.4
- ⑤ Minimum distance between UP and DOWN rail: 110 mm / 4.3"

Electrical connections

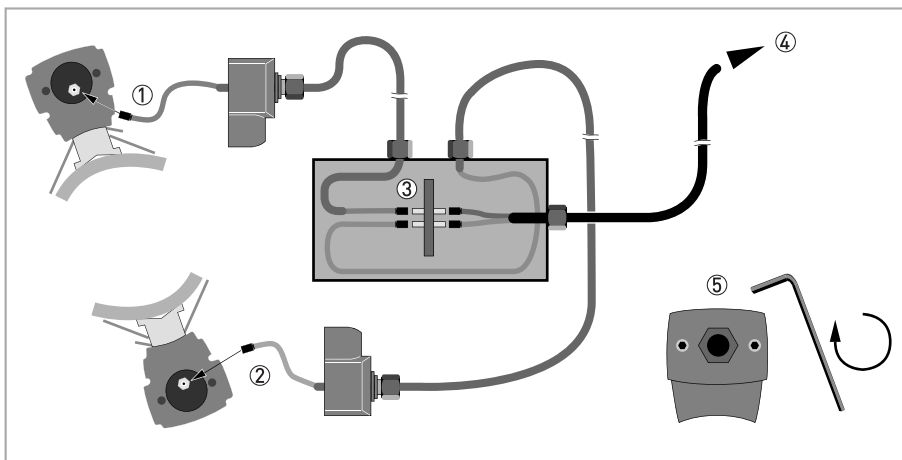

Figure 5-11: Connections in cable box (large version)

- ① Connect the blue cable to the UP rail.
- ② Connect the green cable to the DOWN rail.
- ③ Make connections in cable box.
- ④ Cable to converter
- ⑤ Turn the screws clockwise to secure the caps.

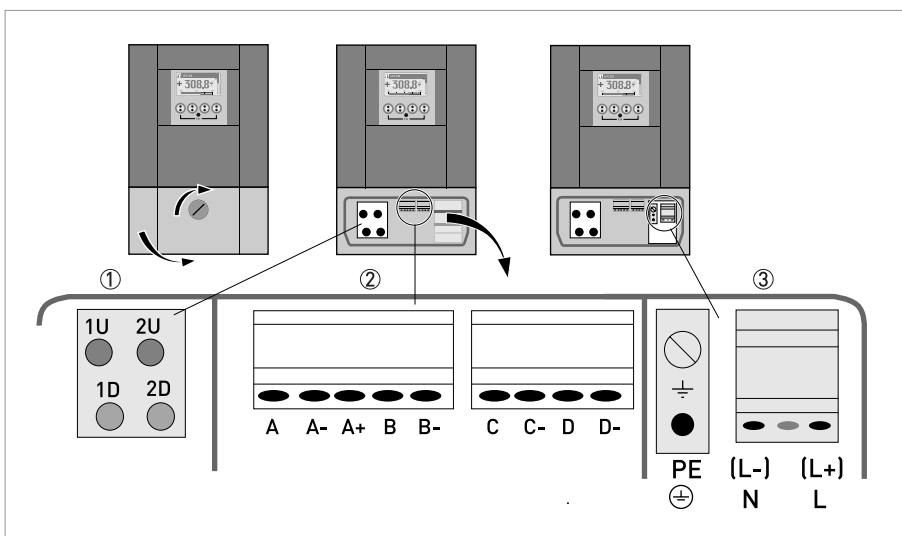

Figure 5-12: Construction of wall version

- ① Connect blue cable to 1U (to 2U for 2nd sensor) and the green cable to 1D (2D for 2nd sensor)
- ② Communication I/O
- ③ Power supply: 24 VAC/DC or 100...240 VAC

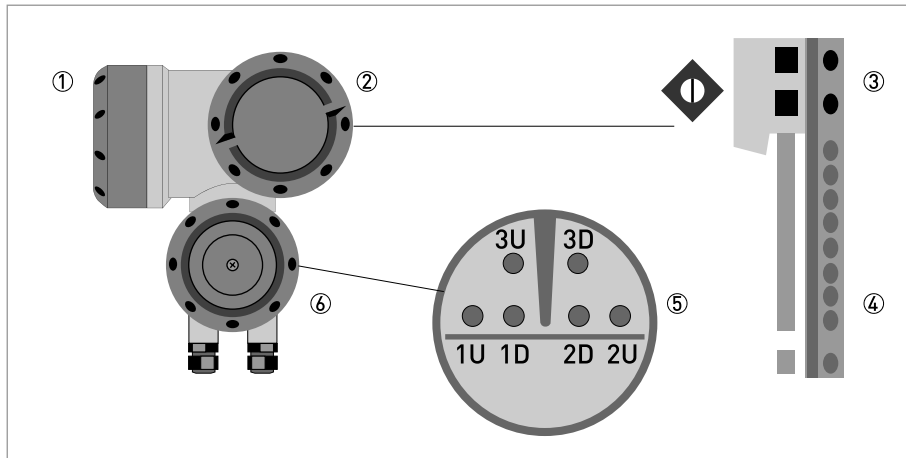

Figure 5-13: Construction (field version)

- ① Cover, electronics compartment
- ② Cover, terminal compartment for power supply and inputs/outputs
- ③ Cable entry for power
- ④ Cable entry for inputs/outputs
- ⑤ Cable entry for sensor cable
- ⑥ Cover, sensor terminal compartment



INFORMATION!

See also the section "Installation menu" in chapter "General instructions for programming".



- Go through menu X1...X7 as described in section "Installation menu" in chapter "General instructions for programming". Correct X5 if needed.
- X9.1: Press enter
- X9.2: Press enter
- X9.3: Press enter
- X9.4: Press enter
- X9.5: Read the preliminary volume flow. Press enter
- X9.6: Check signal

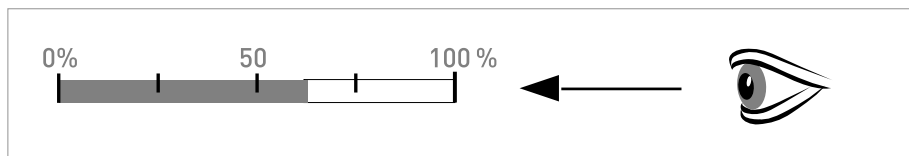

CAUTION!

Advice on signal strength:

Signal > 75%: good signal, optimization loop not needed

Signal 50...75%: fairly good signal, optimization loop can improve the signal

Signal 10...50%: low signal, optimization loop needed

Signal < 10%: bad or no signal, check settings in menu X6, increase transducer distance and/or go into the optimization loop.



- X9.7: Confirm or adjust the reading with the actual distance on the rail.
- X9.8: Optimization loop. Repeat steps X9.8.1...X9.8.5 until the advised mounting distance does not change more than 0.5%.
 - X9.8.1: Optimise distance?
 - X9.8.2: Read the velocity of sound of the fluid
 - X9.8.3: Continue?
 - X9.8.4: Confirm or adjust the velocity of sound
 - X9.8.5: Read the advised mounting distance and reposition the transducer
- X9.9: Read the preliminary volume flow
- X9.10: Path ready? Enter "Yes". If you have:
 - 1 path or pipe: you are finished, proceed with X9.12
 - 2 paths: go to X9 for the 2nd path
 - 2 pipes: go to X10 for the 2nd pipe
- X9.12: End Installation? If you enter "No" the installation is not saved, go to X9. If you enter "Yes" the installation is saved and the measurement screen will appear.
- Mount the cover (see section "mounting the cover" in chapter "General mechanical installation")

6.1 Menu overview

X installation

X1	language
X2	GDC IR interface
X3	units
X4	number of pipes
X5	number of paths
X6	pipe data
X7	pipe data 1
X8	pipe data 2
X9	install transd. 1
X10	install transd. 2
X12	transducer sets

A quick setup

A1	language
A2	Tag
A3	reset
A4	analog outputs
A5	digital outputs
A6	GDC IR interface

B test

B1	simulation
B2	actual values
B3	information

C setup

C1	process input 1
C2	process input 2
C3	process input
C4	transducer sets
C5	IO
C6	IO Counter
C7	IO HART
C8	device



INFORMATION!

You find the description of the **X Installation** menu in Chapter 5 of this handbook

6.2 Menu structure

6.2.1 Quick setup

A1	language	>	english / german / french	↑ ↓	↵
A2	Tag	>	fill in using ↑ ↓ >		↵
A3	reset	>	A3.1, A3.2,...	↑ ↓	
	A3.1	reset errors	yes/no	↑ ↓	↵
	A3.2	counter 1	yes/no	↑ ↓	↵
	A3.3	counter 2	yes/no	↑ ↓	
(underneath counter becomes active if modular IO)					
	A3.4	counter 3	yes/no	↑ ↓	↵
(end)					
A4	analog outputs	>	A4.1, A4.2,...	↑ ↓	
	A4.1	measurement	>	select from list using ↑ ↓ >	↵
			use at all outputs	↑ ↓	
			yes/no		↵
			if no:	only HART current output is selected	
			if yes:	all analog outputs are selected	
	A4.2	unit	>	select from list using ↑ ↓ >	↵
	A4.3	range	>	fill in using ↑ ↓ >	↵
			use at all outputs	↑ ↓	
			yes/no		↵
			if no:	only HART current output is selected	
			if yes:	all analog outputs are selected	
	A4.4	low flow cutoff	>	fill in using ↑ ↓ >	↵
			use at all outputs	↑ ↓	
			yes/no		↵
			if no:	only HART current output is selected	
			if yes:	all analog outputs are selected	
	A4.5	time constant	>	fill in using ↑ ↓ >	↵
			use at all outputs	↑ ↓	
			yes/no		↵
			if no:	only HART current output is selected	
			if yes:	all analog outputs are selected	
A5	digital outputs	>	A5.1, A5.2,...	↑ ↓	
	A5.1	measurement	>	select from list using ↑ ↓ >	↵

				use at all outputs	↑↓	
				yes/no		↵
				if no:	only pulse output D is selected	
				if yes:	all digital outputs are selected	
A5.2	pulse value unit	>		fill in using ↑↓>		↵
				use at all outputs	↑↓	
				yes/no		↵
				if no:	only pulse output D is selected	
				if yes:	all digital outputs are selected	
A5.3	value p. pulse	>		fill in using ↑↓>		↵
				use at all outputs	↑↓	
				yes/no		↵
				if no:	only pulse output D is selected	
				if yes:	all digital outputs are selected	
A5.4	low flow cutoff	>		fill in using ↑↓>		↵
				use at all outputs	↑↓	
				yes/no		↵
				if no:	only pulse output D is selected	
				if yes:	all digital outputs are selected	
A6	GDC IR interface	>		activate/cancel	↑↓	↵

6.2.2 Test

B1	simulation	>	B1.1, B1.2,...	↑↓	
	B1.1	volume flow	>	set value/cancel	↑↓
				start simulation	↑↓
				yes/no	↵
[underneath B1.1 until B1.3 become active if two pipes or two paths are selected in X4 and X5]					
	B1.1	volume flow 1	>	set value/cancel	↑↓
				start simulation	↑↓
				yes/no	↵
	B1.2	volume flow 2	>	submenu identical to B1.1	↑↓
[end]					
	B1.4	vel. of sound	>	set value/cancel	↑↓
				start simulation	↑↓
				yes/no	↵
[underneath B1.4 until B1.5 become active if two pipes or two paths are selected in X4 and X5]					
	B1.4	vel. of sound 1	>		↑↓
				set value/cancel	
				start simulation	↑↓
				yes/no	↵
	B1.5	vel. of sound 2	>	submenu identical to B1.4	↑↓
[end]					
	B1.7	terminal A (depends on IO setting hardware)	>	select from list using ↑↓>	↵
	B1.8	terminal B (depends on IO setting hardware)	>	select from list using ↑↓>	↵
	B1.9	terminal C (depends on IO setting hardware)	>	select from list using ↑↓>	↵
	B1.10	terminal D (depends on IO setting hardware)	>	select from list using ↑↓>	↵
B2	actual values	>		↑↓	
	B.2.1	act. volume flow	>		↑↓
[underneath B2.1.1 until B2.1.2 become active if two pipes are selected in X4 and X5]					
	B2.1.1	pipe 1		read	↵
	B2.1.2	pipe 2		read	↵
[end]					
	B.2.2	act. mass flow	>		↑↓
[additional menus for two pipes]					
	B.2.3	act. Reynolds nr.	>		↑↓
[additional menus for two pipes]					
	B.2.4	act. vel. of sound	>		↑↓
[additional menus for two pipes]					

	B.2.5	act. flow speed	>		↑↓	
(additional menus for two pipes)						
	B.2.6	act. gain	>		↑↓	
(additional menus for two pipes)						
	B.2.7	act. SNR	>		↑↓	
(additional menus for two pipes)						
	B.2.8	act. signal quality	>		↑↓	
(additional menus for two pipes)						
	B.2.9	operating hours	>		↑↓	
B3	information		>	B3.1, B3.2,...	↑↓	
	B3.1	C number		read		↵
	B3.2	process input			↑↓	
	B3.2.1	sensor CPU		read		↵
	B3.2.2	sensor DSP		read		↵
	B3.2.3	sensor driver		read		↵
	B3.3	device		sernr/swnr/yymm dd	↑↓	↵
	B3.4	display		sernr/swnr/yymm dd	↑↓	↵

6.2.3 Setup

C	setup	>		↑↓	
[underneath C1 becomes active if two pipes are selected in X4]					
C1	process input 1	>	C1.1, C1.3,...	↑↓	↵
	C1.1	number of pipes	>	read	↵
	C1.3	pipe data	>	C1.3.1	↑↓
	C1.3.1	pipe tag			
[further submenus C1.3.2 up to C1.3.12 are identical to X6.2 up to X6.13]					
	C1.4	transducer data	>	C1.4.1,...	↑↓ ↵
	C1.4.1	transducer set	>	Ta,Tb,Tc,none	↑↓ ↵
	C1.4.2	number of traverses	>	1,2,4	↑↓ ↵
	C1.4.3	actual distance	>	fill in using ↑↓>	↵
	C1.5	extra measurements	>	select on pipe 1, on pipe 2	↵
	C1.6	calibration	>	C1.6.1, C1.6.2,...	↑↓
	C1.6.1	zero calibration	>	calibrate zero ?	select cancel, automatic, default
	C1.6.2	meter factor	>	fill in using ↑↓>	↵
	C1.6.3	Reynolds correction	>	on,off	↑↓ ↵
	C1.7	filter	>	C1.7.1, C1.7.2,...	↑↓ ↵
	C1.7.1	limitation	>	fill in using ↑↓>	↵
	C1.7.2	flow direction	>	normal/reverse	↑↓ ↵
	C1.7.3	time constant	>	fill in using ↑↓>	↵
	C1.7.4	low flow cutoff	>	fill in using ↑↓>	↵
	C1.8	simulation	>	C1.8.1, C1.8.2,...	↑↓ ↵
	C1.8.1	volume flow	>	set value/cancel	↑↓
				start simulation	↑↓
				yes/no	↵
	C1.8.2	vel. of sound	>		↑↓
				set value/cancel	↑↓
				start simulation	↑↓
				yes/no	↵
	C1.9	plausibility	>	C1.9.1, C1.9.2,...	↑↓ ↵
	C1.9.1	error limit	>	fill in using ↑↓>	↵
	C1.9.2	counter decrease	>	fill in using ↑↓>	↵
	C1.9.3	counter limit	>	fill in using ↑↓>	↵
	C1.10	information	>	C1.10.1, C1.10.2,...	↑↓ ↵
	C1.10.1	sensor CPU		read	
	C1.10.2	sensor DSP		read	↵
	C1.10.3	sensor driver		read	↵
	C1.11	diagnosis value	>	fill in using ↑↓>	↵
C2	process input 2	>		↑↓	

[further submenus C2.1 up to C2.11 are identical to C1.1 up to C1.11]						
[end]						
[underneath C1 becomes active if two paths are selected in X5]						
C1	process input		>	C1.1, C1.2,...	↑↓	
	C1.1	number of pipes	>	read		←
	C1.2	pipe 1: total paths	>	read		←
	C1.3	pipe data	>	C1.3.1, C1.3.2,...	↑↓	←
	C1.3.1	pipe tag				
[further submenus C1.3.2 up to C1.3.12 are identical to X6.2 up to X6.13]						
	C1.4	transducer data	>	C1.4.1, C1.4.2,...	↑↓	
	C1.4.1	transducer set 1	>	Ta,Tb,Tc,none	↑↓	←
	C1.4.2	number of traverses 1	>	1,2,4	↑↓	←
	C1.4.3	actual distance 1	>	fill in using ↑↓>	↑↓	
	C1.4.4	transducer set 2	>	Ta,Tb,Tc,none	↑↓	←
	C1.4.5	number of traverses 2	>	1,2,4	↑↓	←
	C1.4.6	actual distance 2	>	fill in using ↑↓>	↑↓	
	C1.6	calibration	>	C1.6.1, C1.6.2,...	↑↓	←
	C1.6.1	zero calibration	>	calibrate zero ?	select cancel, automatic, default	
	C1.6.2	meter factor	>	fill in using ↑↓>		←
	C1.6.3	Reynolds correction	>	on,off	↑↓	←
	C1.7	filter	>	C1.7.1, C1.7.2,...	↑↓	←
	C1.7.1	limitation	>	fill in using ↑↓>		←
	C1.7.2	flow direction	>	normal/reverse	↑↓	←
	C1.7.3	time constant	>	fill in using ↑↓>		←
	C1.7.4	low flow cutoff	>	fill in using ↑↓>		←
	C1.8	simulation	>	C1.8.1, C1.8.2,...	↑↓	←
	C1.8.1	volume flow	>	set value/cancel	↑↓	
				start simulation	↑↓	
				yes/no		
	C1.8.2	vel. of sound	>	set value/cancel	↑↓	
				start simulation	↑↓	
				yes/no		
	C1.9	plausibility	>	C1.9.1, C1.9.2,...	↑↓	←
	C1.9.1	error limit	>	fill in using ↑↓>		←
	C1.9.2	counter decrease	>	fill in using ↑↓>		←
	C1.9.3	counter limit	>	fill in using ↑↓>		←
	C1.10	information	>	C1.10.1, C1.10.2,...	↑↓	←
	C1.10.1	sensor CPU		read		←
	C1.10.2	sensor DSP		read		←
	C1.10.3	sensor driver		read		←
	C1.11	diagnosis value	>	fill in using ↑↓>		←

C4	transducer sets		>	C4.1, C4.2,...	↑↓	↶
	C4.1	Ta serial no.	>	fill in using ↑↓>		↶
	C4.2	Ta calibration no.	>	fill in using ↑↓>		↶
	C4.3	Tb serial no.	>	fill in using ↑↓>		↶
	C4.4	Tb calibration no.	>	fill in using ↑↓>		↶
	C4.5	Tc serial no.	>	fill in using ↑↓>		↶
	C4.6	Tc calibration no.	>	fill in using ↑↓>		↶
C5	I/O		>	C5.1, C5.2,...	↑↓	
	C5.1	hardware	>	C5.1.1, C5.1.2,...	↑↓	↶
	C5.1.1	terminals A	>	select current output/off using ↑↓		↶
	C5.1.2	terminals B	>	select from list using ↑↓		↶
	C5.1.3	terminals C	>	select from list using ↑↓		↶
	C5.1.4	terminals D	>	select from list using ↑↓		↶
	C5.2	current out A	>	C5.2.1, C5.2.2,...	↑↓	↶
	C5.2.1	range 0-100%	>	fill in using ↑↓>		↶
	C5.2.2	extended range	>	fill in using ↑↓>		↶
	C5.2.3	error current	>	fill in using ↑↓>		↶
	C5.2.4	error condition	>	select from list using ↑↓		↶
	C5.2.5	measurement	>	select from list using ↑↓		↶
	C5.2.6	range	>	fill in using ↑↓>		↶
	C5.2.7	polarity	>	select from list using ↑↓		↶
	C5.2.8	limitation	>	fill in using ↑↓>		↶
	C5.2.9	low flow cutoff	>	fill in using ↑↓>		↶
	C5.2.10	time constant	>	fill in using ↑↓>		↶
	C5.2.11	special function	>	select from list using ↑↓		↶
	C5.2.12	threshold	>	fill in using ↑↓>		↶
	C5.2.13	information	>	read		↶
	C5.2.14	simulation	>	select set on/off/cancel		↶
	C5.2.15	4 mA trimming	>	fill in using ↑↓>		↶
	C5.2.16	20 mA trimming	>	fill in using ↑↓>		↶
	C5.3	frequency out X	>	C5.3.1, C5.3.2,...	↑↓	↶
	C5.3.1	pulse shape	>	select from list using ↑↓		↶
	C5.3.2	pulse width	>	fill in using ↑↓>		↶
	C5.3.3	100 % pulse rate	>	fill in using ↑↓>		↶
	C5.3.4	measurement	>	select from list using ↑↓		↶
	C5.3.5	range	>	fill in using ↑↓>		↶

C5.3.6	polarity	>	select from list using ↑↓		↶
C5.3.7	limitation	>	fill in using ↑↓>		↶
C5.3.8	low flow cutoff	>	fill in using ↑↓>		↶
C5.3.9	time constant	>	fill in using ↑↓>		↶
C5.3.10	invert signal	>	fill in using ↑↓>		↶
C5.3.11	phase shift	>	select from list using ↑↓		↶
C5.3.12	special function	>	fill in using ↑↓>		↶
C5.3.13	information	>	read		↶
C5.3.14	simulation	>	select set on/off/cancel		↶
C5.4	pulse output X	>	C5.4.1, C5.4.2,...	↑↓	↶
C5.4.1	pulse shape	>	select from list using ↑↓		↶
C5.4.2	pulse width		fill in using ↑↓>		↶
C5.4.3	max. pulse rate	>	fill in using ↑↓>		↶
C5.4.4	measurement	>	select from list using ↑↓		↶
C5.4.5	pulse value unit	>	fill in using ↑↓>		↶
C5.4.6	value p. pulse	>	fill in using ↑↓>		↶
C5.4.7	polarity	>	select from list using ↑↓		↶
C5.4.8	low flow cutoff	>	fill in using ↑↓>		↶
C5.4.9	time constant	>	fill in using ↑↓>		↶
C5.4.10	invert signal	>	select on/off		↶
C5.4.11	phase shift		select from list using ↑↓		↶
C5.4.12	special function		select from list using ↑↓		↶
C5.4.13	information	>	read		↶
C5.4.14	simulation	>	select set on/off/cancel		↶
C5.5	status output X	>	C5.5.1, C5.5.2,...	↑↓	↶
C5.5.1	mode	>	select from list using ↑↓		↶
C5.5.2	current output Y	>	select from list using ↑↓		↶
C5.5.3	frequency output Y	>	select from list using ↑↓		↶
C5.5.4	pulse output Y	>	select from list using ↑↓		↶
C5.5.5	status output Y	>	select from list using ↑↓		↶
C5.5.6	limit switch Y	>	read: status off		↶
C5.5.7	control input Y	>	read: status off		↶
C5.5.8	off	>	read: status off		↶
C5.5.9	invert signal	>	select on/off		↶
C5.5.10	information	>	read		↶

	C5.5.11	simulation	>	select set on/off/cancel		↵
	C5.6	limit switch X	>	C5.6.1, C5.6.2,...	↑↓	↵
	C5.6.1	measurement	>	select from list using ↑↓		↵
	C5.6.2	threshold	>	fill in using ↑↓>		↵
	C5.6.3	polarity	>	select from list using ↑↓		↵
	C5.6.4	time constant	>	fill in using ↑↓>		↵
	C5.6.5	invert signal	>	select on/off		↵
	C5.6.6	information	>	read		↵
	C5.6.7	simulation	>	select set on/off/cancel		↵
	C5.7	control input X	>	C5.7.1, C5.7.2,...	↑↓	↵
	C5.7.1	mode	>	select from list using ↑↓		↵
	C5.7.2	invert signal	>	select on/off		↵
	C5.7.3	information	>	read		↵
	C5.7.4	simulation	>	select set on/off/cancel		↵
[active if HART device]						
	C6	I/O Counter	>	C6.1, C6.2	↑↓	
	C6.1	counter 1	>	C6.1.1, C6.1.2,...	↑↓	↵
	C6.1.1	function of counter	>	select from list using ↑↓		↵
	C6.1.2	measurement	>	select from list using ↑↓		↵
	C6.1.3	low flow cutoff	>	fill in using ↑↓>		↵
	C6.1.4	time constant	>	fill in using ↑↓>		↵
	C6.1.5	preset value	>	fill in using ↑↓>		↵
	C6.1.6	reset counter	>	select yes/no		↵
	C6.1.7	set counter	>	select set on/off/cancel		↵
	C6.1.8	stop counter	>	select yes/no		↵
	C6.1.9	start counter	>	select yes/no		↵
	C6.1.10	information	>	read		↵
	C6.2	counter 2	>	C6.2.1, C6.2.2,...	↑↓	
[underneath submenus identical to C6.1.1 to C6.1.10]						
	C7	I/O HART	>	C7.1, C7.2,...	↑↓	
	C7.1	PV is	>	C7.1.1, C7.1.2,...	↑↓	↵
	C7.1.1	current output A	>	read		↵
[depends on I/O configuration]						
	C7.1.2	frequency output X	>	read		↵
	C7.1.3	HART dynamic variable	>	select from list using ↑↓		↵
	C7.2	SV is	>	C7.2.1		
	C7.2.1	HART dynamic variable	>	select from list using ↑↓		↵

	C7.3	TV is	>	C7.3.1		
	C7.3.1	HART dynamic variable	>	select from list using ↑↓		↶
	C7.4	4V is	>	C7.4.1		
	C7.4.1	HART dynamic variable	>	select from list using ↑↓		↶
[end]						
C8	device		>	C8.1, C8.2,...	↑↓	
	C8.1	device info	>	C8.1.1, C8.1.2,...	↑↓	↶
	C8.1.1	Tag	>	fill in using ↑↓>		↶
	C8.1.2	C number	>	read		↶
	C8.1.3	device serial no.	>	read		↶
	C8.1.4	electronic serial no.	>	read		↶
	C8.1.5	information	>	read		↶
	C8.2	display	>	C8.2.1, C8.2.2,...	↑↓	↶
	C8.2.1	language	>	select from list using ↑↓		↶
	C8.2.2	contrast	>	fill in using ↑↓>		↶
	C8.2.3	default display	>	select from list using ↑↓		↶
	C8.2.5	information	>	read		↶
	C8.3	1. meas. page	>	C8.3.1, C8.3.2,...	↑↓	
	C8.3.1	function	>	select from list using ↑↓		↶
(if two or three lines: C5.3.8 etc active)						
	C8.3.2	measurement 1.line	>	select from list using ↑↓		↶
	C8.3.3	range	>	fill in using ↑↓>		↶
	C8.3.4	limitation	>	fill in using ↑↓>		↶
	C8.3.5	low flow cutoff	>	fill in using ↑↓>		↶
	C8.3.6	time constant	>	fill in using ↑↓>		↶
	C8.3.7	format 1.line	>	select from list using ↑↓		↶
	C8.3.8	measurement 2.line	>	select from list using ↑↓		↶
	C8.3.9	format 2.line	>	select from list using ↑↓		↶
	C8.3.10	measurement 3.line	>	select from list using ↑↓		↶
	C8.3.11	format 3.line	>	select from list using ↑↓		↶
	C8.4	2. meas. page	>	C8.4.1, C8.4.2,...	↑↓	
(underneath submenus identical to C8.3.1 to C8.3.11)						
	C8.5	graphic page	>	C8.5.1, C8.5.2,...	↑↓	↶
	C8.5.1	select range	>	select manual/automatic		↶
	C8.5.2	range	>	fill in using ↑↓>		↶
	C8.5.3	time scale	>	fill in using ↑↓>		↶

C8.6	special functions	>	C8.6.1, C8.6.2,...	↑↓	←
C8.6.1	reset errors	>	select yes/o		←
C8.6.2	save settings	>	select from list using ↑↓		←
C8.6.3	load settings	>	select from list using ↑↓		←
C8.6.4	password quick setup	>	fill in 4 digits using ↑↓>		←
C8.6.5	password setup	>	fill in 4 digits using ↑↓>		←
C8.6.6	GDC IR interface	>	activate/cancel		←
C8.7	units	>	C8.7.1, C8.7.2,...	↑↓	←
C8.7.1	size				
C8.7.2	volume flow	>	select from list using ↑↓		←
C8.7.3	mass flow	>	select from list using ↑↓		←
C8.7.4	velocity	>	select from list using ↑↓		←
C8.7.5	volume	>	select from list using ↑↓		←
C8.7.6	mass	>	select from list using ↑↓		←
C8.7.7	density	>	select from list using ↑↓		←
C8.7.8	viscosity	>	select from list using ↑↓		←
C8.8	HART	>	C8.8.1, C8.8.2,...	↑↓	←
C8.8.1	HART	>	select on/off		←
C8.8.2	address	>	fill in 2 digits using ↑↓>		←
C8.8.3	message	>	fill in using ↑↓>		←
C8.8.4	description	>	fill in using ↑↓>		←
C8.9	quick setup	>	C8.9.1, C8.9.2,...	↑↓	←
C8.9.1	reset counter 1	>	select yes/no		←
C8.9.2	reset counter 2	>	select yes/no		←
C8.9.3	reset counter 3	>	select yes/no		←

6.2.4 Customize settings

After installation the display switches to the first measurement screen.

The converter has 4 different display pages:

- 2 measurement pages
- 1 graphical page
- 1 status page

Using the ↓↑ buttons, you can switch between the displayed pages.

Customizing used transducers sets:

To alter settings in the menu, keep button > pressed until "Release key now" appears in the display.

X12 transducer sets

X12	transducer sets		>	X12.1, X12.2,...	↑↓	
	X12.1	Ta serial no.	>	fill in using ↑ ↓ >		←
	X12.2	Ta calibration no.	>	fill in using ↑ ↓ >		←
	X12.3	Tb serial no.	>	fill in using ↑ ↓ >		←
	X12.4	Tb calibration no.	>	fill in using ↑ ↓ >		←
	X12.5	Tc serial no.	>	fill in using ↑ ↓ >		←
	X12.6	Tc calibration no.	>	fill in using ↑ ↓ >		←

6.3 Function description

Menu No.	Display	Function description	Selection list
X	Installation		
X3	units		
X3.1	size	unit for dimension	mm, inch
X3.2	volume flow	unit for volume flow	L/s, L/min, L/h, m ³ /s, m ³ /min, m ³ /h, m ³ /d, ft ³ /s, ft ³ /min, ft ³ /h, gal/s, gal/min, gal/h, gal/d, lG/s, lG/min, lG/h, lG/d, bbl/h, bbl/d, free unit
X3.3	velocity	unit for flow speed and velocity of sound (VoS)	m/s, ft/s
X3.4	density	unit for density	kg/L, kg/m ³ , lb/ft ³ , lb/gal, free unit
X3.5	viscosity	unit for viscosity	cSt, mm ² /s
X5	number of paths	in case "2 paths" is selected, the measurement results will be averaged	1 path, 2 paths
X6.3	diameter	size for outer diameter of pipe	min-max: 20 - 4300 mm / 0.787 - 169.3 inch
X6.4	pipe material		carbon steel, stainless steel, cast iron, aluminum, concrete, GRF/RFP, asbestos cement, PP/PVC, acrylics, polyamide, other
X6.5	VoS pipe material		min-max: 1000.0 - 4500.0 m/s / 3280.8 - 14764 ft/s
X6.6	wall thickness		min-max: 1.000 - 200.0 mm / 0.039 - 7.874 inch
X6.7	liner material		cement, epoxy, PP, LDPE, HDPE, PTFE, rubber, other, none
X6.8	VoS liner material		min-max: 1000.0 - 4500.0 m/s / 3280.8 - 14764 ft/s
X6.9	liner thickness		min-max: 0.100 - 20.00 mm / 0.004 - 0.787 inch
X6.10	fluid		water, alkanes, alcohols, oil, acids, CxHx refined, CxHx light, refrigerant, solvents, caustic soda, other
X6.11	VoS fluid		min-max: 500 - 2500 m/s / 1640.4 - 8202.1 ft/s
X6.12	density		min-max: 0.1000 - 5.0000 kg/l / 6.2428 lb/ft ³ to 312.14 lb/ft ³
X6.13	viscosity		min-max: 0.100 cSt to 9999 cSt (mm ² /s)
X9.1	transducer set	short code for transducer set, mentioned on sensor	Ta, Tb, Tc, none
X9.7	actual distance		min-max: -10.00 - +9999 mm / -0.394 - +393.7 inch
X12.1/3/5	Tx serial no.	factory serial number of sensor	Ayy, 5 free units
X12.2/4/6	Tx calibration no.	set calibration number of sensor according to type sticker	9 free units

A Quick setup

A	quick setup		
A1	language		english, german, french, dutch
A2	Tag	unique location in plant	12 free selectable digits
A4	analog outputs	only active if HART device	current output A, B or C, pulse output A, B or D
A4.1	measurement	value for HART current output	(depends on pipe configuration: 1 or 2 pipes) volume flow, mass flow, VoS, flow speed, gain, SNR, diagnosis value, volume flow 1 or 2, VoS 1 or 2

A4.2	unit	unit for HART current output	L/s, L/min,L/h, m3/s, m3/min, m3/h, m3/d, ft3/s, ft3/min, ft3/h, gal/s, gal/min,gal/h, gal/d, IG/s, IG/min, IG/h, IG/d, bbl/h, bbl/d, free unit
A4.3	range	range for main HART current output	min-max: 0.00 - xxxx (depends on configuration)
A4.4	low flow cutoff	low flow cutoff for main HART current output	min-max: 00.0 - 20.0
A4.5	time constant	time constant for main HART current output	min-max: 000.1 - 100.0
A5	digital outputs	only active if HART device	pulse output A, B or D, counter 1
A5.1	measurement	value for pulse output	(depends on pipe configuration: 1 or 2 pipes) volume flow, mass flow, volume flow 1 or 2
A5.2	pulse value unit	unit for main pulse output	(unit class depends on selected measurement)
A5.3	value p. pulse	value of pulse per volume or mass for pulse output	(min-max depends on selected measurement)
A5.4	low flow cutoff	low flow cutoff for pulse output	(min-max depends on selected measurement)

B Test

B	test		
B1.7	terminal A	(depends on IO setting hardware)	current output A, frequency output A, pulse output A, status output A, limit switch A, control input A
B1.8	terminal B	(depends on IO setting hardware)	current output B, frequency output B, pulse output B, status output B, limit switch B, control input B
B1.9	terminal C	(depends on IO setting hardware)	current output C, status output C, limit switch C
B1.10	terminal D	(depends on IO setting hardware)	frequency output D, pulse output D, status output D, limit switch D
B3.1	C number	identification of electronics	also see converter sticker; first line: circuit board, second line: software, third line:calibration or production date
B3.2.1	Sensor CPU	identification of hardware and software for flow processing	also see sensor board of electronics
B3.2.2	Sensor DSP	identification of hardware and software for signal processing	also see sensor board of electronics
B3.2.3	Sensor driver	identification of hardware and software for driver part	also see sensor board of electronics
B3.3	Device	identification of circuit board	serial number of circuit board, main software version number, production date

C Setup

C	setup		
C1.5	extra measurements	extra available parameters for display or input/output	(only for dual pipe configuration: 1, 2 pipes) on pipe 1: mass flow, flow speed, gain, SNR on pipe 2: mass flow, flow speed, gain, SNR
C1.6.1	zero calibration	transit time offset at zero flow	cancel, default, automatic min-max: -10000 - +10000 ps
C1.6.2	meter factor	set factor for correction of volume flow, mass flow, flow speed and Reynolds number	min-max: 0.500 - 2.000
C1.6.3	Reynolds correction	set Reynolds correction for flow profile disturbances, effective on volume flow, mass flow	on,off

C1.7.1	limitation	set lower and upper limit for flow speed on all outputs	min-max: -100 - +100 m/s
C1.7.2	flow direction	select flow direction	normal, reverse
C1.7.3	time constant	within set time, measurements are averaged, displayed and sent to current output	min-max: 000.0 - 100.0 s
C1.7.4	low flow cutoff	beneath set flow speed, zero appears in display	min-max: 0.000 - 10.00 m/s / 0.000 - 32.81 ft/s
C1.8.2	vel. of sound	simulation of the VoS	min-max: 0.0000 - 2500.0 m/s / 0.0000 - 8202.1 ft/s
C1.9.1	error limit	with set limits, every erroneous measurement is counted as percentage of the measured values	min-max: 000 - 100 %
C1.9.2	counter decrease	amount with which the counter decreases	min-max: 00 - 99
C1.9.3	counter limit	totalized correct measurements equal to set counter decrease, decrease error limit by 1	min-max: 000 - 999
C1.11	diagnosis value	diagnosis of the flow measurement	signal quality, Reynolds number
C5.1	I/O Hardware		
C5.1.1	terminals A	assign terminal A	for basic I/O: current output, off for Modular I/O: free selectable 1st IO Module
C5.1.2	terminals B	assign terminal B	for basic I/O: status output, limit switch, control input for Modular I/O: free selectable 2nd IO Module
C5.1.3	terminals C	assign terminal C	for basic I/O: status output, limit switch, off for Modular I/O: fixed current out
C5.1.4	terminals D	assign terminal D	for basic I/O: status output, limit switch, pulse output, frequency output, off for Modular I/O: fixed current out
C5.2	current out A		
C5.2.1	range 0-100%	set current range	min-max: 04.0 - 20.0 mA
C5.2.2	extended range	set upper current range to extended value	min-max: 03.5 - 21.5 mA
C5.2.3	error current	after error this selected current is set	min-max: 03.0 - 22.0 mA
C5.2.4	error condition		error in device, out of specification, application error
C5.2.5	measurement	measurement value to current output	(depends on pipe configuration: 1 or 2) volume flow, mass flow, VoS, flow speed, gain, SNR, diagnosis value, volume flow 1 or 2, VoS 1 or 2
C5.2.6	range	set measurement range from 0 to 100 %	(min-max depends on parameter settings)
C5.2.7	polarity	set polarity of current output	positive -, negative -, both polarity(ies), absolute value
C5.2.8	limitation	set lower and upper limit for current output	min-max: -150 - +150 %
C5.2.9	low flow cutoff	beneath set value, current output is set to zero	min-max: 00.0 - 20.0
C5.2.10	time constant	within set time, measurements are averaged, displayed and sent to current output	min-max: 000.1 - 100.0
C5.2.11	special functions	for ranging	automatic range, external range, off

C5.2.12	threshold	inactive if C5.2.11 is set to off: set lag value between normal and extended range	min-max: 05.0 - 80.0
C5.2.13	information	serial number of circuit board, software version, calibration date of circuit board	
C5.2.14	simulation A	simulation of current output A	set value:on/off, cancel min-max: 00.0 - 22.0 mA
C5.2.15	4 mA trimming	restore factory setting for 4 mA	min-max: 3.6000 - 5.5000 mA
C5.2.16	20 mA trimming	restore factory setting for 20 mA	min-max: 18.500 - 21.500 mA
C5.3	frequency output		
C5.3.1	pulse shape	set shape	symmetric, automatic, fixed
C5.3.2	pulse width	active if C2.3.1 is set to fixed: set time for pulse activation	min-max: 0000.05 - 2000.00
C5.3.3	100 % pulse rate		min-max: 00000.0 - 10000.0
C5.3.4	measurement	measurement value to frequency output	(depends on pipe configuration: 1 or 2 pipes) volume flow, mass flow, VoS, flow speed, gain, SNR, diagnosis value, volume flow 1 or 2, VoS 1 or 2
C5.3.5	range	set measurement range from 0 to 100 %	(min-max depends on parameter settings)
C5.3.6	polarity	set polarity of frequency output	both polarities
C5.3.7	limitation	set lower and upper limit for frequency output	min-max: -150 - +150 %
C5.3.8	low flow cutoff	set low values to zero	min-max: 00.0 - 20.0
C5.3.9	time constant	within set time, measurements are averaged, displayed and sent to current output	min-max: 000.1 - 100.0
C5.3.10	invert signal	define frequency output activation	off: activate high current/switch closed on: low current/switch open
C5.3.11	phase shift	phase shift between output B and D	0, 90, 180 degrees
C5.3.12	special function	for ranging	off, phase shift
C5.3.13	information		
C5.3.14	simulation	simulation of frequency output	on, off, cancel
C5.4	pulse output		
C5.4.1	pulse shape	set shape	symmetric, automatic, fixed
C5.4.2	pulse width	set time for pulse activation	available if pulse shape is set: fixed min-max: 0000.05 - 2000.00
C5.4.3	max. pulse rate		min-max: 00000.0 - 10000.0 Hz
C5.4.4	measurement	measurement value to pulse output	(depends on pipe configuration: 1 or 2 pipes) volume flow, mass flow, volume flow 1 or 2
C5.4.5	pulse value unit	unit for pulse output	mL, L, free unit
C5.4.6	value p. pulse	value of pulse per volume or mass for pulse output	no min-max
C5.4.7	polarity	set polarity of pulse output	positive -, negative -, both polarity(ies), absolute value
C5.4.8	low flow cutoff	set low values to zero	min-max: 00.0 - 20.0
C5.4.9	time constant	within set time, measurements are averaged, displayed and sent to current output	min-max: 000.1 - 100.0
C5.4.10	invert signal	activate switch closed, open	off, on

C5.4.11	phase shift	phase shift between output B and D	0, 90, 180 degrees
C5.4.12	special function	for ranging	off, phase shift
C5.4.13	information	serial number of circuit board, software version, calibration date of circuit board	
C5.4.14	simulation	simulation of pulse output	on, off, cancel
C5.5	status output		
C5.5.1	mode	output is activated if an error occurs	(depends on pipe configuration: 1 or 2 pipes) off, error in device, application error, out of specification, empty pipe, polarity flow, over range flow, application error 1 or 2, out of specification 1 or 2, empty pipe 1 or 2, polarity flow 1 or 2, over range flow 1 or 2, counter 1 preset, counter 2 preset, output A/B/C/D
C5.5.2	current output Y	active if selected under status output mode (C2.5.1) output Y and output is current output	polarity, over range, automatic range
C5.5.3	frequency output Y	active if selected under status output mode (C2.5.1) output Y and output is frequency output	polarity, over range
C5.5.4	pulse output D	active if selected under status output mode (C2.5.1) output Y and output is pulse output	polarity, over range
C5.5.5	status output Y	active if selected under status output mode (C2.5.1) output Y and output is status output	same signal, inverted signal
C5.5.6	limit switch Y	active if selected under status output mode (C2.5.1) output Y and output is limit switch	off
C5.5.7	control input Y	active if selected under status output mode (C2.5.1) output Y and output is control input	off
C5.5.8	off	active if selected under status output mode (C2.5.1) output Y and output is switched off	off
C5.5.9	invert signal	define status output activation	off: activate high current/switch closed on: low current/switch open
C5.5.10	information	serial number of circuit board, software version, calibration date of circuit board	
C5.5.11	simulation	simulation of status output	on, off, cancel
C5.6	limit switch X		
C5.6.1	measurement	measurement value to limit switch	(depends on pipe configuration: 1 or 2 pipes) volume flow, mass flow, VoS, flow speed, gain, SNR, diagnosis value, volume flow 1 or 2, VoS 1 or 2
C5.6.2	threshold	1e: switch level 2e:time lag	min-max: 500.0 - 2500 m/s
C5.6.3	polarity	set polarity of limit switch	positive -, negative -, both polarity(ies), absolute value
C5.6.4	time constant	within set time, measurements are averaged, displayed and sent to current output	min-max: 000.1 - 100.0
C5.6.5	invert signal	define limit switch activation	off: high current by exceeded limit on: low current by exceeded limit
C5.6.6	information	serial number of circuit board, software version, calibration date of circuit board	

C5.6.7	simulation	simulation of limit switch	on, off, cancel
C5.7	control input X		
C5.7.1	mode	define function of control input	off, hold all outputs, hold output X, all outputs to zero, output X to zero, reset all counters, reset counter X, stop all counters, stop counter X, zero outp.+ stop cnt, range change X, error reset
C5.7.2	invert signal		off: activate a current on: activate no current
C5.7.3	information	serial number of circuit board, software version, calibration date of circuit board	
C5.7.4	simulation	simulation of control input	on, off, cancel
C6	I/O Counter		
C6.1...6.2	Counter 1 and 2	only if HART device	
C.x.1	function of counter	define counter	off, +counter, -counter, sum counters
C.x.2	measurement	select the measurement for the counter	(depends on pipe configuration: 1 or 2 pipes) volume flow, mass flow, volume flow 1 or 2
C.x.3	low flow cutoff	set low values to zero	(depends on parameter settings)
C.x.4	time constant	within set time, measurements are averaged, displayed and sent to current output	min-max: 000.1 - 100.0
C.x.5	preset value	active when under status output mode (C2.5.1) preset counter X is selected	min-max: 0.00000 - 1.00 +15
C.x.6	reset counter		yes/no
C.x.7	set counter	select set value	on, off, cancel
C.x.8	stop counter	stop counter and hold actual value	yes/no
C.x.9	start counter	start after stop counter	yes/no
C.x.10	information	serial number of circuit board, software version, calibration date of circuit board	
C7	I/O HART	only if HART device; HART dynamic values are linked to analog outputs	free selectable only if analog output is NOT active
C7.1	PV is	Primary Variable; linked to HART current output	
C7.1.1	current output A	show selected value	
C7.1.2	frequency output X	show selected value	
C7.1.3	HART dynamic variable	select the variable	(depends on pipe configuration: 1 or 2 pipes) volume flow, mass flow, VoS, flow speed, gain, SNR, diagnosis value, volume flow 1 or 2, VoS 1 or 2, counter 1 or 2, operating hours
C7.2	SV is	Secondary Variable; linked to frequency output D	
C7.3	TV is	Third Variable	
C7.4	4V is	Fourth Variable	
C8	device		
C8.2.2	contrast		min-max: -9 - +9
C8.2.3	default display		1.meas.page, 2.meas.page, graphic page, status page, none

C8.3		settings for first and second measurement display	
C8.3.1	function		one, two, three line(s)
C8.3.2	measurement 1.line		(depends on pipe configuration: 1 or 2 pipes) volume flow, mass flow, VoS, flow speed, gain, SNR, diagnosis value, volume flow 1 or 2, VoS 1 or 2
C8.3.3	range	set measurement range from 0 to 100 %	(depends on parameter settings)
C8.3.4	limitation	set lower and upper limit	min-max: -150 - +150 %
C8.3.5	low flow cutoff	set low values to zero	min-max: 00.0 - 20.0
C8.3.6	time constant	within set time, measurements are averaged, displayed and sent to current output	min-max: 000.1 - 100.0
C8.3.7	format 1.line	number of decimals	automatic, No.x.xxxx (no - four decimals)
C8.3.8	measurement 2.line		bargraph, operating hours, counter 1, counter 2, diagnosis value, SNR, gain, flow speed, mass flow, VoS, volume flow
C8.5.1	select range	set Y-axis scaling	manual, automatic
C8.5.2	range	active if under select range (C5.5.1) manual is selected	min-max: -100 - +100%
C8.5.3	time scale	set X-axis scaling	min-max: 001 - 100 min
C8.6.2	save settings		factory settings, back up 1, back up 2, cancel
C8.6.3	load settings		factory settings, back up 1, back up 2, cancel
C8.6.4	password quick setup		0000 - 9999
C8.6.5	password setup		0000 - 9999
C8.7	units		
C8.7.1	volume flow		L/s, L/min, L/h, m ³ /s, m ³ /min, m ³ /h, m ³ /d, ft ³ /s, ft ³ /min, ft ³ /h, gal/s, gal/min, gal/h, gal/d, IG/s, IG/min, IG/h, IG/d, bbl/h, bbl/d, free unit
C8.7.2	mass flow		kg/s, kg/min, kg/h, t/min, t/h, t/d, lb/s, lb/min, lb/h, ST/min, ST/h, ST/d, LT/h, LT/d, gs, g/min, g/h, free unit
C8.7.3	flow speed		m/s, ft/s
C8.7.4	velocity		m/s, ft/s
C8.7.5	volume		m ³ , in ³ , ft ³ , yd ³ , mL, L, hL, gal, IG, bbl, free unit
C8.7.6	mass		mg, g, kg, t, oz, lb, ST, LT, free unit
C8.7.7	density		kg/L, kg/m ³ , lb/ft ³ , lb/gal, free unit
C8.7.8	viscosity		cSt, m ² /s, mm ² /s
C8.8.1	HART	factory setting: HART communication on; generates F: application error open circuit A	

6.4 Error messages

Error code	Group message	Error message	Description	Error handling
F (bold)	error in device		no measurement possible, measured values are not valid	repair or replace device and/or CPU; contact manufacturer service center
F	application error		no measurement possible, but device ok	check parameter settings / power off - wait 5 seconds - power on device
S	out of specification		unreliable measurement	maintenance required, check flowprofile
C	check in progress		test function is active, device is stand-by	wait until finished
I	information		no direct impact on measurements	no action needed
F (bold)		IO 1 (or IO 2)	error or failure of IO Module 1 (or 2)	try to load settings (menu C8.6.3); if error does not disappear, replace electronics unit
F (bold)		parameter	error or failure of data manager, parameter or hardware error	try to load settings (menu C8.6.3); if error does not disappear, replace electronics unit
F (bold)		configuration	incorrect configuration or no confirmation	confirm change of module; if configuration is unchanged, replace electronics unit
F (bold)		display	error of failure of display unit, parameter or hardware error	defect; replace electronics units
F (bold)		current output A (or B, C)	error or failure of the current output A (or B, C), parameter or hardware error	defect; replace electronics units
F (bold)		software user interface		defect; replace electronics units
F (bold)		hardware settings	detected hardware and set hardware settings do not match	follow display instructions
F (bold)		hardware detection	hardware can not be detected	defect; replace electronics units
F (bold)		RAM/ROM error IO 1 (or IO 2)		defect; replace electronics units
F (bold)		communication dsp-up	no communication between DSP and microprocessor PCB	contact manufacturer service center
F (bold)		front end	malfunctioning of front end PCB	contact manufacturer service center
F (bold)		uproc	malfunctioning of microcontroller PCB	contact manufacturer service center
F (bold)		dsp	malfunctioning of DSP	contact manufacturer service center
F		empty pipe	signal lost at two paths	check process conditions
F		flow > max 1	max volume flow exceeded for pipe 1	check parameter in menu C1.7.1
F		flow > max 2	max volume flow exceeded for pipe 2	check parameter in menu C1.7.1
F		open circuit A (or B, C)	current on current output A (or B, C) too low	check cable or reduce resistance (< 1000 Ohm)
F		over range A (or B, C)	current on current output A (or B, C) is limited by parameter setting	extend upper or lower limit for current output in menu C5.2.8

Error code	Group message	Error message	Description	Error handling
F		over range A (or B, D)	pulse on frequency output A (or B, D) is limited by parameter setting	extend upper or lower limit for frequency output in menu C5.3.7
F		active settings	error during CRC check (Cyclic Redundancy Check) of the active settings	load settings; factory setting, back up 1 or back up 2
F		factory settings	error during CRC check of factory settings	
F		back up 1 (or 2) settings	error during CRC check of back up 1 (or 2) settings	
F		signal lost path 1	signal lost at path 1	check signal cable / check for pipe obstructions
F		signal lost path 2	signal lost at path 2	check signal cable / check for pipe obstructions
F		pipe/sens1 param.	unrealistic parameter settings for pipe in combination with path 1	check parameters in menu X6
F		pipe/sens2 param.	unrealistic parameter settings for pipe in combination with path 2	check parameters in menu X6
S		unreliable 1	unreliable measurement at pipe 1	check process conditions for gas bubbles, solids
S		unreliable 2	unreliable measurement at pipe 2	check process conditions for gas bubbles, solids
S		zero converter	invalid value at power up	power off - wait 5 seconds - power on device
S		overflow counter 1 (or 2, 3)	counter is overflowing and will start again at zero	no action needed
S		backplane invalid	error during CRC check of backplane	restore data records on backplane
I		counter 1 (or 2, 3) stopped	counter has stopped	reset counter in menu C8.9.1 (or C8.9.2, C8.9.3)
I		control input A (or B) active	information only	no action needed
I		over range display 1 (or 2)	1 st row on 1 st (or 2 nd) measurement page is limited by parameter setting	extend upper or lower limit for limitation in menu C8.3.4
I		backplane sensor	incompatible data sensor on backplane	
I		backplane settings	incompatible data on backplane	
I		backplane difference	different data on backplane and display	
I		optical interface	optical interface is operational, local display can not be used	
I		softw sync error	incompatible DSP and microprocessor software	

7.1 Periodic maintenance

7.1.1 Regreasing of transducers

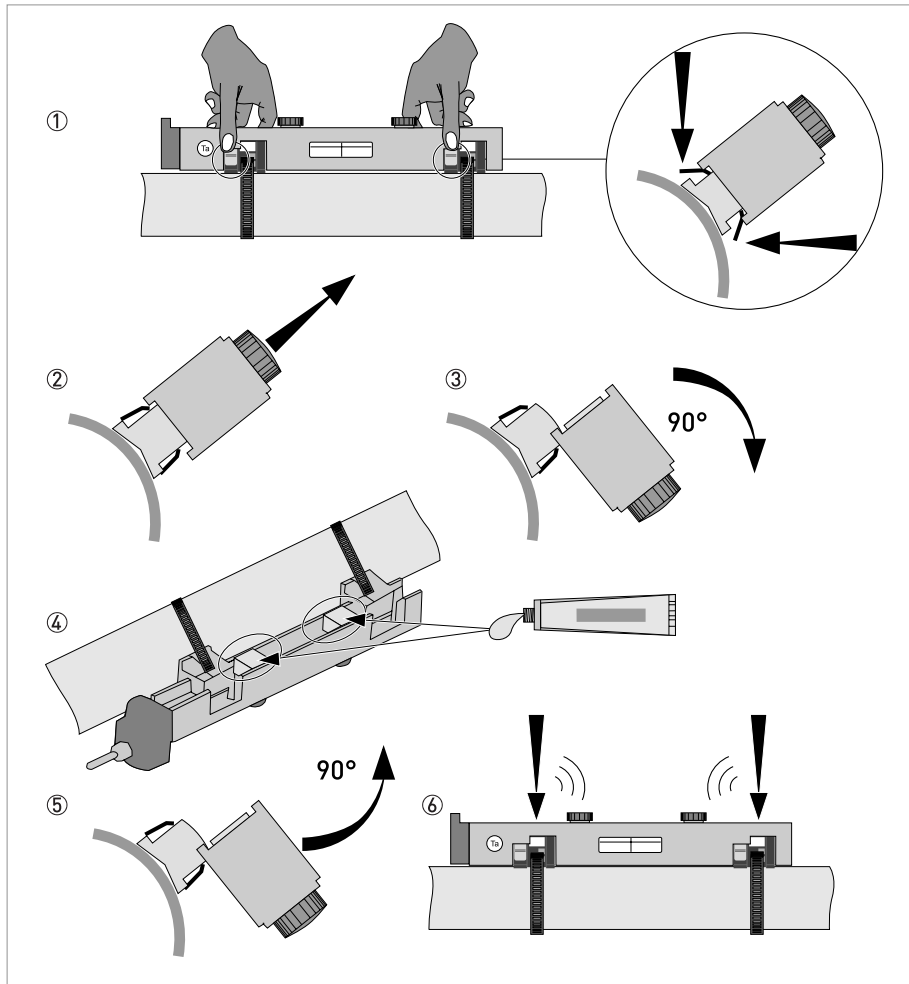

Figure 7-1: Greasing of transducers



- Loosen cover by unscrewing screw, slide cover away from connection cap, lift cover, place cover in safe place to avoid damage.
- Push buttons to release the rail ①.
- Lift rail upward ② and turn rail 90 degrees sideward ③.
Clean pipe and contact surfaces of transducers with a soft cloth.
- Regrease the contact surfaces of transducers ④.
- Turn rail 90 degrees back ⑤.
- Press rail at both ends to the pipe by clicking ⑥.

7.2 Cleaning

Instructions for signal converter:



INFORMATION!

Each time a housing cover is opened, the thread should be cleaned and greased. Use only resin-free and acid-free grease.

Ensure that the housing gasket is properly fitted, clean and undamaged.

7.3 Exchange of electronics unit

Before opening the converter housing:



DANGER!

All work on the electrical connections may only be carried out with the power disconnected. Take note of the voltage data on the nameplate!



WARNING!

Observe without fail the local occupational health and safety regulations. Any work done on the electrical components of the measuring device may only be carried out by properly trained specialists.



INFORMATION!

Make notes of important specific data, before exchanging the electronics.

Menu settings are stored on the circuit board (or backplane), that is fixed to the housing. After exchange of electronics unit and power-up, the following start up screen appears:

Load all data?



- Select yes
- ☞ - if in the screen appears “**load sensor data**”, the electronics units were not fully compatible. You can proceed by selecting yes. Note that all settings need to be checked and changed. Only the sensor calibration data are loaded.
- if in the screen appears “**load no data**”, all data have been lost. Contact your local representative.

7.3.1 Field version

**DANGER!**

All work on the electrical connections may only be carried out with the power disconnected. Take note of the voltage data on the nameplate!

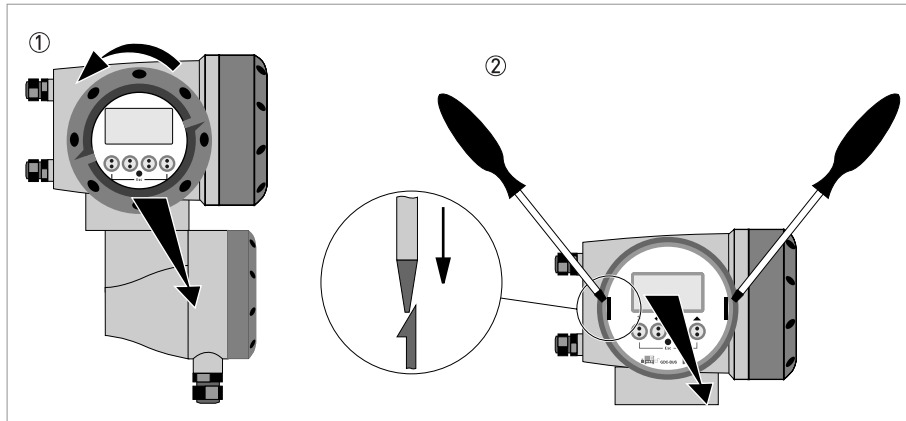

Figure 7-2: Unscrew the cover and remove the display

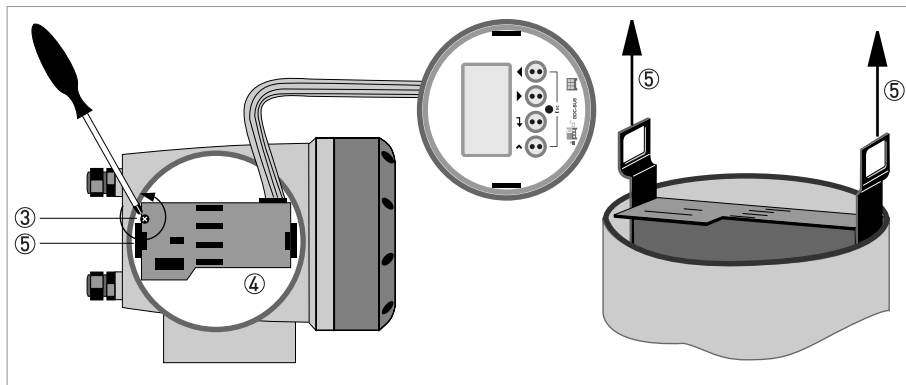

Figure 7-3: Pull off printed circuit board

**Perform the following procedures:**

- Unscrew the display cover of the electronics compartment by hand, by turning it counter clockwise ①.
- Remove the display by using two screwdrivers ②.
- Unscrew the two M4 screws ③ at the electronics unit ④.
- Pull the two metal pullers ⑤ at the left and right of the display, using a screwdriver or similar tool and partially pull out the electronics unit.

**CAUTION!**

Please pay attention that the same amount of force is applied on both pullers, otherwise the connector at the backside can be damaged.

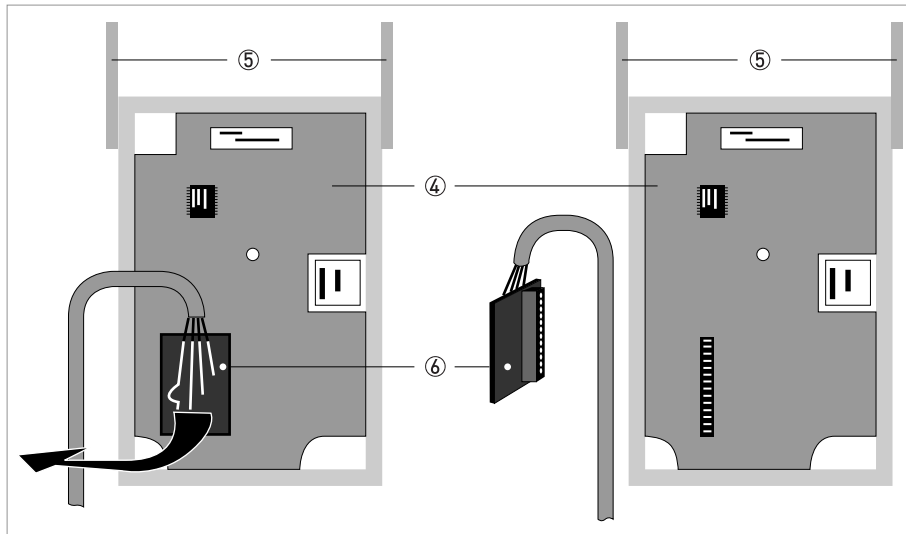

Figure 7-4: Small printed circuit board and electronics unit



DANGER!

Electrostatic discharge (ESD) can damage electronic parts. Make sure to discharge yourself by wearing a wrist strap. If no wrist strap is available, ground yourself by touching a metal surface that is grounded.



- Remove the printed circuit board ⑥ from the electronics unit ④.
- Check compatibility between the removed and new electronics unit ④, by checking the power voltage.
- Slide the new electronics unit ④ partially back into the housing.
- Mount the small printed circuit board back onto the electronics unit ④.
- Push the metal pullers ⑤ back to their original position.
Don't use excessive force, otherwise the connector at the backside can be damaged!
- Screw the electronics unit back to the housing.
- Re-install the display and make sure not to kink the display's flat ribbon cable.
- Replace cover and tighten by hand.
- Connect power.

7.3.2 Wall version

**DANGER!**

All work on the electrical connections may only be carried out with the power disconnected. Take note of the voltage data on the nameplate!

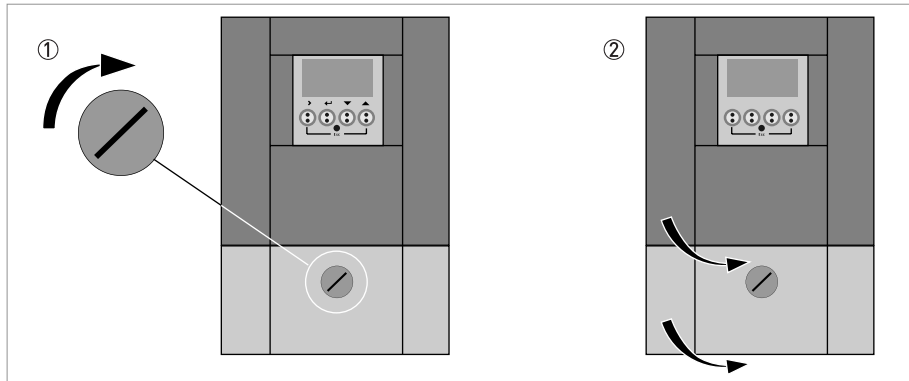

Figure 7-5: Unlock and open door

**Perform the following procedures:**

- Turn locking screw to the left ① to unlock the lower door.
- Open lower door.
- Slide metal slider, positioned at the left upper angle, downwards.
- Open upper door ②.

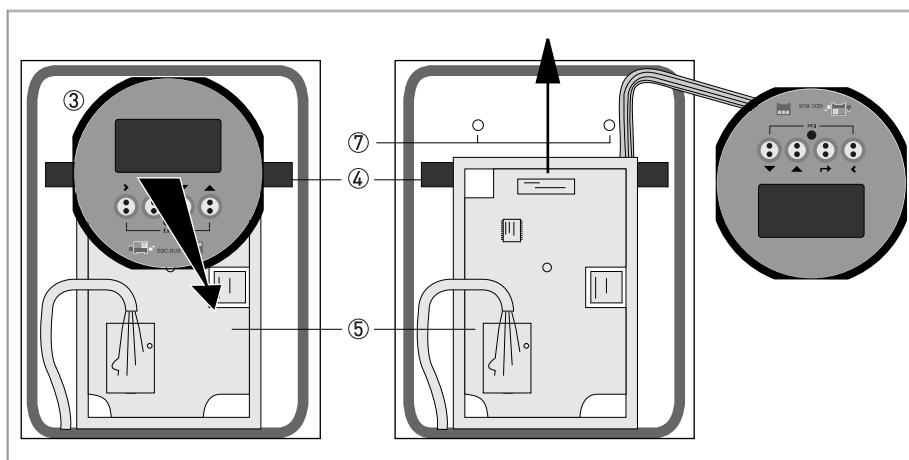

Figure 7-6: Remove the display



- Remove the display ③ by pressing the plastic holders on both sides ④ and carefully lay the display aside.
- Unscrew the two M4 screws ⑦ at the electronics unit ⑤.

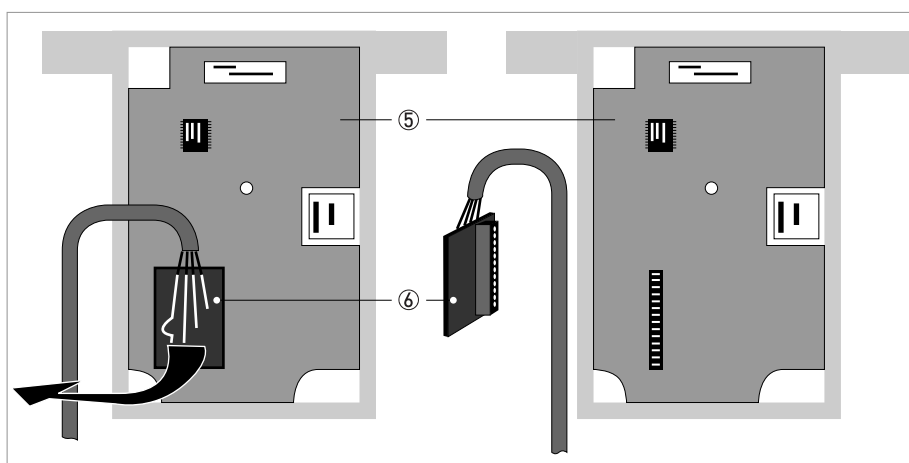

Figure 7-7: Release printed circuit board



- Remove the small printed circuit board ⑥ with care.
- Carefully slide the electronics unit ⑤, then lift it out of the housing.

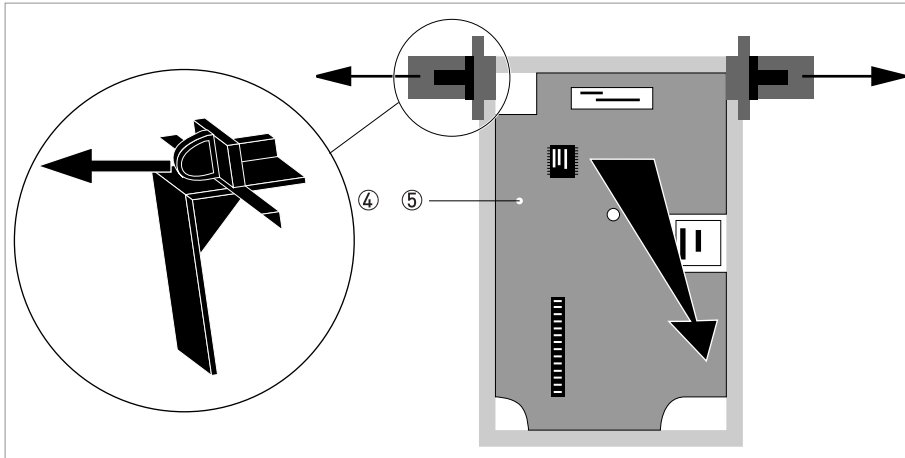

Figure 7-8: Remove holding brackets



- Remove the holding brackets ④ from the old electronics unit ⑤.
- Check compatibility between the removed and new electronics unit, by checking the power voltage.
- Click the holding brackets ④ onto the new electronics unit and slide the new electronics unit into the housing.
- Mount the small printed circuit board back onto the sensor driver board.
- Screw the electronics unit back to the housing.
- Click the display back into the holders.
- Close and lock the upper door, slide the metal slider upwards.
- Close and lock the lower door.
- Connect power.



CAUTION!

First program the installation menu, refer to General instructions for programming on page 56 and check all important settings.

7.4 Replacing the mains fuse

**DANGER!**

All work on the electrical connections may only be carried out with the power disconnected. Take note of the voltage data on the nameplate!

**WARNING!**

Observe without fail the local occupational health and safety regulations. Any work done on the electrical components of the measuring device may only be carried out by properly trained specialists.

Underneath codings for the mains fuse apply:

- **100...230VAC power supply:** 0.8AT/H/250 , breaking capacity 1500 A at 250 V
- **24VAC/DC power supply:** 2AT/H/250 , breaking capacity 1500 A at 250 V

The mains fuse is in accordance with IEC 127-2. The size is diameter 5 x 20 mm / 0.79" length.

Underneath codings for the mains fuse apply:

- **100...230 VAC power supply:**
0.8AT/H/250 , breaking capacity 1500 A at 250 V
- **24 VAC/DC power supply:**
2AT/H/250 , breaking capacity 1500 A at 250 V

7.4.1 Field version



INFORMATION!

Please refer to *Field version* on page 97 for details how to open the housing and remove / reinstall the electronics.

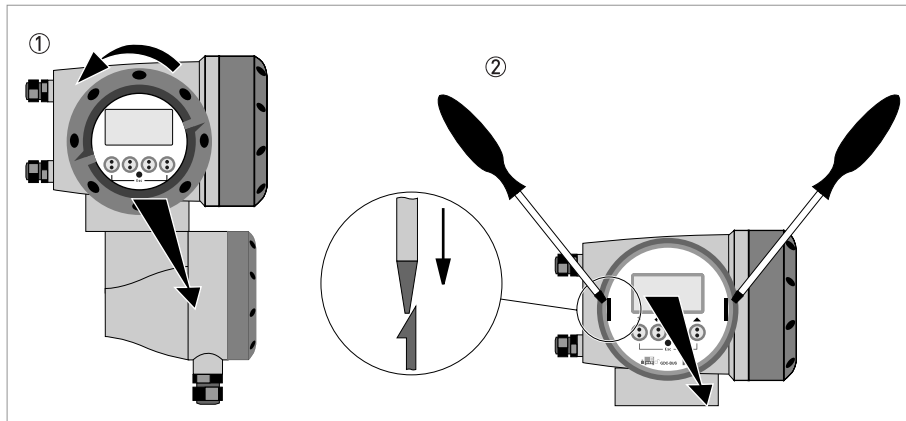

Figure 7-9: Unscrew the cover and remove the display



Once the electronic unit is removed,

- Replace the fuse. The fuse holder with the mains fuse is located on the power board, which is the upper board.
- Reinstall the electronics unit back to the housing.
- Reinstall cover and tighten down by hand ① and connect power.

7.4.2 Wall version



INFORMATION!

Please refer to *Wall version* on page 99 for details how to open the housing and remove the electronics.



Once the electronic unit is removed,

- Replace the fuse. The fuse holder with the mains fuse is located on the power board, which is at the back.
- Mount the small printed circuit board back onto the sensor driver board.
- Put the electronics unit back to the housing.
- Click the display back into the holders.
- Close the housing and lock the doors.
- Connect power.

7.5 Spare parts availability

The manufacturer adheres to the basic principle that functionally adequate spare parts for each device or each important accessory part will be kept available for a period of 3 years after delivery of the last production run for the device.

This regulation only applies to spare parts which are under normal operating conditions subjects to wear and tear.

7.6 Availability of services

The manufacturer offers a range of services to support the customer after expiration of the warranty. These include repair, technical support and training.



INFORMATION!

For more precise information, please contact your local representative.

7.7 Returning the device to the manufacturer

7.7.1 General information

This device has been carefully manufactured and tested. If installed and operated in accordance with these operating instructions, it will rarely present any problems.



CAUTION!

Should you nevertheless need to return a device for inspection or repair, please pay strict attention to the following points:

- *Due to statutory regulations on environmental protection and safeguarding the health and safety of our personnel, manufacturer may only handle, test and repair returned devices that have been in contact with products without risk to personnel and environment.*
- *This means that the manufacturer can only service this device if it is accompanied by the following certificate (see next section) confirming that the device is safe to handle.*



CAUTION!

If the device has been operated with toxic, caustic, flammable or water-endangering products, you are kindly requested:

- *to check and ensure, if necessary by rinsing or neutralizing, that all cavities are free from such dangerous substances,*
- *to enclose a certificate with the device confirming that is safe to handle and stating the product used.*

7.7.2 Form (for copying) to accompany a returned device

Company:		Address:	
Department:		Name:	
Tel. no.:		Fax no.:	
Manufacturer's order no. or serial no.:			
The device has been operated with the following medium:			
This medium is:	water-hazardous		
	toxic		
	caustic		
	flammable		
	We checked that all cavities in the device are free from such substances.		
	We have flushed out and neutralized all cavities in the device.		
We hereby confirm that there is no risk to persons or the environment through any residual media contained in the device when it is returned.			
Date:		Signature:	
Stamp:			

7.8 Disposal

**CAUTION!**

Disposal must be carried out in accordance with legislation applicable in your country.

8.1 Measuring principle

- Like canoes crossing a river, acoustic signals are transmitted and received along a diagonal measuring path.
- A sound wave going downstream with the flow travels faster than a sound wave going upstream against the flow.
- The difference in transit time is directly proportional to the mean flow velocity of the medium.

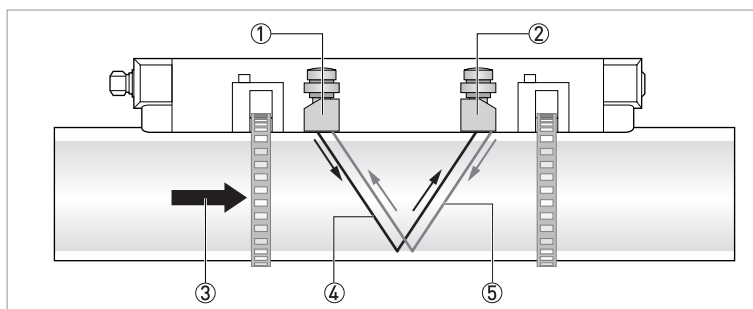

Figure 8-1: Measuring principle

- ① Transducer A
- ② Transducer B
- ③ Flow velocity
- ④ Transit time from transducer A to B
- ⑤ Transit time from transducer B to A

8.2 Technical data



INFORMATION!

- The following data is provided for general applications. If you require data that is more relevant to your specific application, please contact us or your local representative.
- Additional information (certificates, special tools, software,...) and complete product documentation can be downloaded free of charge from the website (Downloadcenter).

Measuring system

Measuring principle	Ultrasonic transit time
Application range	Flow measurement of liquids
Measured value	
Primary measured value	Transit time
Secondary measured value	Volume flow, mass flow, flow speed, flow direction, speed of sound, gain, signal to noise ratio, diagnosis value, reliability of flow measurement, quality of acoustic signal

Design

	The measurement system consists of a measuring sensor and a signal converter. It is only available as separate version.
Signal converter	
Wall-mounted housing (W) - remote version	UFC 300 W (general purpose)
Field housing (F) - remote version	UFC 300 F (Option: Ex version)
Measuring sensor	
Standard	Small, medium or large version in aluminum
Optional	Small / medium stainless steel version Small / medium XT (eXtended Temperature).
Diameter ranges	
Small	DN15...100 / ½...4"
	Outer diameter must be at least 20 mm / 0.79".
Medium	DN50...400 / 2...16"
Large	DN200...4000 / 8...160"
	Outer diameter must be smaller than 4300 mm / 169.29".
Options	
Inputs / outputs	Current (incl. HART®), pulse, frequency and/or status output, limit switch and/or control input (depending on the I/O version)
Counters	2 internal counters with a max. of 8 counter places (e.g. for counting volume and/or mass units)
Self diagnostics	Integrated verification, diagnosis functions: flowmeter, process, measured value, empty pipe detection, bargraph

Display and user interface	
Graphic display	LC display, backlit white
	Size: 128x64 pixels, corresponds to 59x31 mm = 2.32"x1.22"
	Display turnable in 90° steps
	The readability of the display could be reduced at ambient temperatures below -25°C / -13°F.
Operator input elements	4 optical keys for operator control of the signal converter without opening the housing.
	Option: Infrared interface (GDC)
Remote control	PACTware® including Device Type Manager (DTM)
	All DTM's and drivers are available at the internet homepage of the manufacturer.
Display functions	
Menu	Programming of parameters at 2 measured value pages, 1 status page, 1 graphic page (measured values and descriptions adjustable as required)
Language of display texts	English, French, German
Units	Metric, British and US units selectable from list / free unit

Measuring accuracy

Reference conditions	Medium: water
	Temperature: 20°C / 68°F
	Straight inlet section: 10 DN
Maximum measuring error	±1% of the measured value for DN≥50 mm / 2" and v > 0.5 m/s / 1.5 ft/s
	±3% of the measured value for DN<50 mm / 2" and v > 0.5 m/s / 1.5 ft/s
Repeatability	<±0.2%

Operating conditions

Temperature	
Process temperature	Standard version: -40...+120°C / -40...+248°F
	XT version: -40...+200°C / -40...+392°F
Ambient temperature	Sensor: -40...+70°C / -40...+158°F
	Signal converter: -40...+60°C / -40...+140°F (ambient temperature 55°C / 131°F and higher: protect electronics against self-heating, because an increase in the electronics temperature in 10°C / 50°F steps leads to a corresponding reduction of the electronics' service life by a factor of two).
Storage temperature	-50...+70°C / -58...+158°F
Pipe specifications	
Material	Metal, plastic, ceramic, asbestos cement, internal / external coated pipes (coatings and liners fully bonded to pipe wall)
Pipewall thickness	< 200 mm / 7.87"
Liner thickness	< 20 mm / 0.79"

Media properties	
Physical condition	Liquids
Viscosity	< 100 cSt (general guideline)
	For detailed information please contact your local representative.
Permissible gas content (volume)	≤ 2%
Permissible solid content (volume)	≤ 5%
Recommended flow velocity	0.5...20 m/s
Other conditions	
Protection category acc. to IEC 529 / EN 60529	W (Wall) version signal converter: IP 65 (acc. to NEMA 4/4x)
	F (Field) version signal converter: IP 66/67 (acc. to NEMA 4x/6)
	All sensors: IP 67 (acc. to NEMA 6)
Vibration resistance	IEC 68-2-64
Shock resistance	IEC 60068-2-27

Installation conditions

Measurement configuration	Single path, single pipe or dual path / dual pipe
Inlet run	≥ 10 DN straight length
Outlet run	≥ 5 DN straight length
Dimensions and weights	See chapter "Dimensions and weights"

Materials

Sensor	Standard
	Anodised aluminum
	Option stainless steel / eXtended Temperature (small / medium version)
	Rail construction: 1.4404 (AISI 316L) Cable connection: 1.4404, PSU with FKM O-ring
Converter	Standard
	F version: die-cast aluminum, polyurethane coated W version: polyamide-polycarbonate
	Option
	F version: stainless steel 316 L (1.4408)

Electrical connections

Voltage	Standard: 100...230 VAC (-15% / +10%), 50/60 Hz
	Option: 24 VAC/DC (AC: -15% / +10%; DC: -25% / +30%)
Power consumption	AC: 22 VA
	DC: 12 W
Signal cable	double shielded, 2 internal triax, available lengths:
	5 m / 15 ft (standard), maximum length 30 m / 90 ft
Cable entries	Standard: M20 x 1.5
	Option: ½" NPT, PF ½

Inputs and outputs

General	All in- and outputs are galvanically isolated from each other and from all other circuits		
Description of used abbreviations	U_{ext} = external voltage; R_L = load + resistance; U_0 = terminal voltage; I_{nom} = nominal current		
Current output			
Output data	Measurement of volume and mass (at constant density), HART [®] communication		
Settings	Without HART[®]		
	Q = 0%: 0...20 mA; Q = 100%: 10...21.5 mA		
	Error identification: 0...22 mA		
	With HART[®]		
	Q = 0%: 4...20 mA; Q = 100%: 10...21.5 mA		
	Error identification: 3.5...22 mA		
Operating data	Basic I/Os	Modular I/Os	Ex-i
Active	$U_{\text{int,nom}} = 24 \text{ VDC}$ $I \leq 22 \text{ mA}$ $R_L \leq 1 \text{ k}\Omega$		$U_{\text{int,nom}} = 20 \text{ VDC}$ $I \leq 22 \text{ mA}$ $R_L \leq 450 \Omega$
			$U_0 = 21 \text{ V}$ $I_0 = 90 \text{ mA}$ $P_0 = 0.5 \text{ W}$ $C_0 = 90 \text{ nF} /$ $L_0 = 2 \text{ mH}$ $C_0 = 110 \text{ nF} /$ $L_0 = 0.5 \text{ mH}$
Passive	$U_{\text{ext}} \leq 32 \text{ VDC}$ $I \leq 22 \text{ mA}$ $U_0 \geq 1.8 \text{ V at } I = 22 \text{ mA}$		$U_{\text{ext}} \leq 32 \text{ VDC}$ $I \leq 22 \text{ mA}$ $U_0 \geq 4 \text{ V}$ $R_L \leq (U_{\text{ext}} - U_0) / I_{\text{max}}$
			$U_1 = 30 \text{ V}$ $I_1 = 100 \text{ mA}$ $P_1 = 1 \text{ W}$ $C_1 = 10 \text{ nF}$ $L_1 \sim 0 \text{ mH}$
HART[®]			
Description	HART [®] protocol at active and passive current output		
	HART [®] version: V5		
	Universal HART [®] parameter fully integrated		
Load	$\geq 250 \Omega$ Please observe maximum value for current output		
Multidrop	Yes, current output = 4 mA		
	Multidrop addresses programmable in menu 1...15		
Device drivers	FDT/DTM		

Pulse or frequency output				
Output data	Volume or mass counting			
Function	Can be set as a pulse output or frequency output			
Settings	For Q = 100%: 0.01...10000 pulses per second or pulses per unit volume			
	Pulse width: setting automatic, symmetric or fixed (0.05...2000 ms)			
Operating data	Basic I/Os	Modular I/Os	Ex-i	
Active	-	U _{nom} = 24 VDC	-	
		f_{max} ≤ 100 Hz: I ≤ 20 mA open: I ≤ 0.05 mA closed: U _{0, nom} = 24 V at I = 20 mA 100 Hz < f_{max} ≤ 10 kHz: I ≤ 20 mA open: I ≤ 0.05 mA closed: U _{0, nom} = 22.5 V at I = 1 mA U _{0, nom} = 21.5 V at I = 10 mA U _{0, nom} = 19 V at I = 20 mA		
Passive	U _{ext} ≤ 32 VDC	-	-	
				f_{max} ≤ 100 Hz: I ≤ 100 mA open: I ≤ 0.05 mA at U _{ext} = 32 VDC closed: U _{0, max} = 0.2 V at I ≤ 10 mA U _{0, max} = 2 V at I ≤ 100 mA
				100 Hz < f_{max} ≤ 10 kHz: I ≤ 20 mA open: I ≤ 0.05 mA at U _{ext} = 32 VDC closed: U _{0, max} = 1.5 V at I ≤ 1 mA U _{0, max} = 2.5 V at I ≤ 10 mA U _{0, max} = 5.0 V at I ≤ 20 mA
NAMUR	-	Passive to EN 60947-5-6 open: I _{nom} = 0.6 mA closed: I _{nom} = 3.8 mA	Passive to EN 60947-5-6 open: I _{nom} = 0.43 mA closed: I _{nom} = 4.5 mA	
		U _I = 30 V I _I = 100 mA P _I = 1 W C _I = 10 nF L _I ~ 0 mH		

Status output / limit switch			
Function and settings	Settable as automatic measuring range change, indicator for direction of flow, overflow, error, operating point or empty pipe detection		
	Valve control with activated dosing function		
	Status and/or control: ON or OFF		
Operating data	Basic I/Os	Modular I/Os	Ex-i
Active	-	$U_{int} = 24 \text{ VDC}$ $I \leq 20 \text{ mA}$ open: $I \leq 0.05 \text{ mA}$ closed: $U_{0, nom} = 24 \text{ V}$ at $I = 20 \text{ mA}$	-
Passive	$U_{ext} \leq 32 \text{ VDC}$ $I \leq 100 \text{ mA}$ open: $I \leq 0.05 \text{ mA}$ at $U_{ext} = 32 \text{ VDC}$ closed: $U_{0, max} = 0.2 \text{ V}$ at $I \leq 10 \text{ mA}$ $U_{0, max} = 2 \text{ V}$ at $I \leq 100 \text{ mA}$	$U_{ext} = 32 \text{ VDC}$ $I \leq 100 \text{ mA}$ $R_{L, max} = 47 \text{ k}\Omega$ open: $I \leq 0.05 \text{ mA}$ at $U_{ext} = 32 \text{ VDC}$ closed: $U_{0, max} = 0.2 \text{ V}$ at $I \leq 10 \text{ mA}$ $U_{0, max} = 2 \text{ V}$ at $I \leq 100 \text{ mA}$	-
NAMUR	-	Passive to EN 60947-5-6 open: $I_{nom} = 0.6 \text{ mA}$ closed: $I_{nom} = 3.8 \text{ mA}$	Passive to EN 60947-5-6 open: $I_{nom} = 0.43 \text{ mA}$ closed: $I_{nom} = 4.5 \text{ mA}$ $U_I = 30 \text{ V}$ $I_I = 100 \text{ mA}$ $P_I = 1 \text{ W}$ $C_I = 10 \text{ nF}$ $L_I = 0 \text{ mH}$

Control input			
Function	Hold value of the outputs [e.g. for cleaning work], set value of the outputs to "zero", counter and error reset, range change.		
	Start of dosing when dosing function is activated.		
Operating data	Basic I/Os	Modular I/Os	Ex-i
Active	-	$U_{int} = 24 \text{ VDC}$ Terminals open: $U_{0, nom} = 22 \text{ V}$ Terminals bridged: $I_{nom} = 4 \text{ mA}$ On: $U_0 \geq 12 \text{ V}$ with $I_{nom} = 1.9 \text{ mA}$ Off: $U_0 \leq 10 \text{ V}$ with $I_{nom} = 1.9 \text{ mA}$	-
Passive	$8 \text{ V} \leq U_{ext} \leq 32 \text{ VDC}$ $I_{max} = 6.5 \text{ mA}$ at $U_{ext} \leq 24 \text{ VDC}$ $I_{max} = 8.2 \text{ mA}$ at $U_{ext} \leq 32 \text{ VDC}$ Contact closed (On): $U_0 \geq 8 \text{ V}$ with $I_{nom} = 2.8 \text{ mA}$ Contact open (Off): $U_0 \leq 2.5 \text{ V}$ with $I_{nom} = 0.4 \text{ mA}$	$3 \text{ V} \leq U_{ext} \leq 32 \text{ VDC}$ $I_{max} = 9.5 \text{ mA}$ at $U_{ext} \leq 24 \text{ V}$ $I_{max} = 9.5 \text{ mA}$ at $U_{ext} \leq 32 \text{ V}$ Contact closed (On): $U_0 \geq 3 \text{ V}$ with $I_{nom} = 1.9 \text{ mA}$ Contact open (Off): $U_0 \leq 2.5 \text{ V}$ with $I_{nom} = 1.9 \text{ mA}$	$U_{ext} \leq 32 \text{ VDC}$ $I \leq 6 \text{ mA}$ at $U_{ext} = 24 \text{ V}$ $I \leq 6.6 \text{ mA}$ at $U_{ext} = 32 \text{ V}$ On: $U_0 \geq 5.5 \text{ V}$ or $I \geq 4 \text{ mA}$ Off: $U_0 \leq 3.5 \text{ V}$ or $I \leq 0.5 \text{ mA}$ $U_I = 30 \text{ V}$ $I_I = 100 \text{ mA}$ $P_I = 1 \text{ W}$ $C_I = 10 \text{ nF}$ $L_I = 0 \text{ mH}$
NAMUR	-	Active to EN 60947-5-6 Contact open: $U_{0, nom} = 8.7 \text{ V}$ Contact closed (On): $I_{nom} = 7.8 \text{ mA}$ Contact open (off): $U_{0, nom} = 6.3 \text{ V}$ with $I_{nom} = 1.9 \text{ mA}$ Identification for open terminals: $U_0 \geq 8.1 \text{ V}$ with $I \leq 0.1 \text{ mA}$ Identification for short circuited terminals: $U_0 \leq 1.2 \text{ V}$ with $I \geq 6.7 \text{ mA}$	-
Low-flow cutoff			
On	0...±9.999 m/s; 0...20.0%, settable in 0.1% steps, separately for each current and pulse output		
Off	0...±9.999 m/s; 0...19.0%, settable in 0.1% steps, separately for each current and pulse output		
Time constant			
Function	Can be set together for all flow indicators and outputs, or separately for: current, pulse and frequency output, and for limit switches and the 3 internal counters		
Time setting	0...100 seconds, settable in 0.1 second steps		

Approvals and certificates

Hazardous areas	
ATEX	Sensor:
	PTB 06 ATEX 2045 X
	II 2 G Ex ia IIC T6...T4 (XT Version: II 2 G Ex ia IIC T6...T2)
	Converter (F version only):
	PTB 06 ATEX 2046 X
	II 2(1) G Ex de [ia] IIC T6 or II 2 G Ex de [ia] IIC T6 II 2(1) G Ex d [ia] IIC T6 or II 2 G Ex d [ia] IIC T6
FM - Class I, DIV 1/2	Option (F version): approval ID = 3029326
	Pending for stainless steel / eXtended Temperature version.
CSA - GP / Class I, DIV 1/2	Option (F version): approval certificate = 1956404 (LR 105802)
	Pending for stainless steel / eXtended Temperature version.
Other approvals and standards	
Electromagnetic compatibility	Directive: 89/336/EEC, NAMUR NE21/04
	Harmonized standard: EN 61326-1: 2006
Low Voltage Directive	Directive: 2006/95/EC
	Harmonized standard: EN 61010: 2001

8.3 Dimensions and weights

8.3.1 Housing

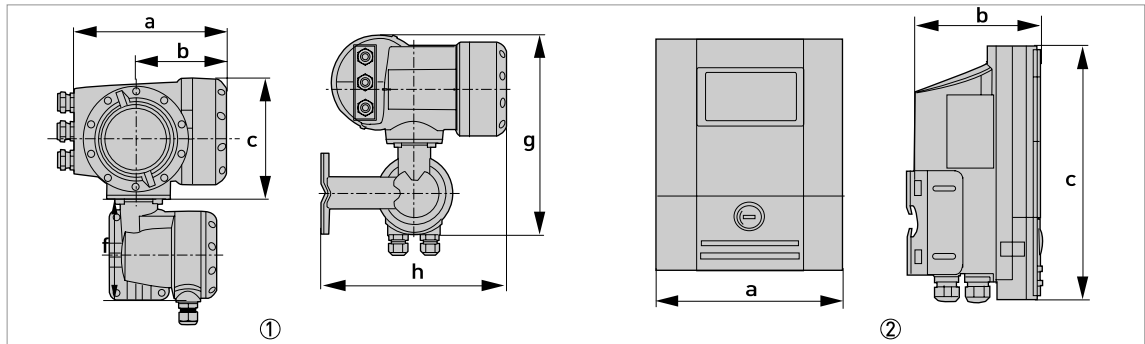

① Field housing (F) - remote version

② Wall-mounted housing (W) - remote version

Dimensions and weights in mm and kg

Version	Dimensions [mm]					Weights [kg]
	a	b	c	g	h	
F	202	120	155	295.8	277	5.7
W	198	138	299	-	-	2.4

Dimensions and weights in inches and lbs

Version	Dimensions [inches]					Weights [lbs]
	a	b	c	g	h	
F	7.75	4.75	6.10	11.60	10.90	12.60
W	7.80	5.40	11.80	-	-	5.30

8.3.2 Clamp-on sensor and cable box

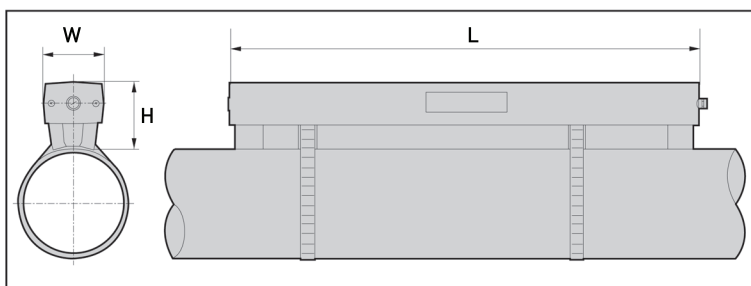

Version	Dimensions [mm]			Approx. weight (without cable / strip) [kg]
	L	H	W	
Small	496.3	71	63.1	2.7
Medium	826.3	71	63.1	3.6
Large	496.3 ①	71 ①	63.1 ①	2.7 ①
Small - stainless steel / XT ②	493	65.5	48	2.1
Medium - stainless steel / XT ②	823	65.5	48	2.7

① value for one of the 2 delivered rails

② delivered without cover

Version	Dimensions [inches]			Approx. weight (without cable / strip) [lbs]
	L	H	W	
Small	19.5	2.8	2.5	6.0
Medium	32.5	2.8	2.5	7.9
Large	19.5 ①	2.8 ①	2.5 ①	6.0 ①
Small - stainless steel / XT ②	19.4	2.6	1.9	4.6
Medium - stainless steel / XT ②	32.4	2.6	1.9	6.0

① value for one of the 2 delivered rails

② delivered without cover

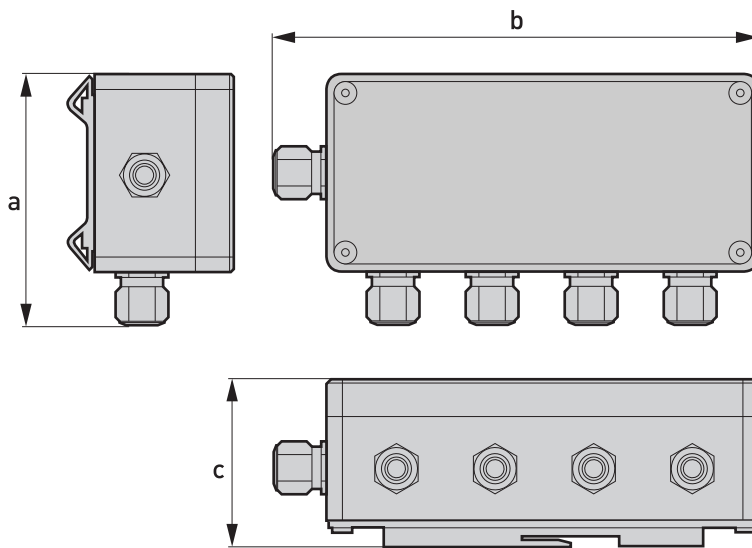

	Dimensions [mm]			Approx. weight without cable/metal [kg]
	a	b	c	
Cable box	102	197	67	0.85

	Dimensions [inches]			Approx. weight without cable/metal [lbs]
	a	b	c	
Cable box	4.01	7.76	2.64	1.87

8.3.3 Mounting plate, field housing

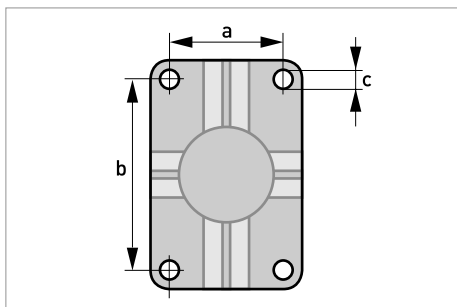

Dimensions in mm and inches

	[mm]	[inches]
a	60	2.4
b	100	3.9
c	Ø9	Ø0.4

8.3.4 Mounting plate, wall-mounted housing

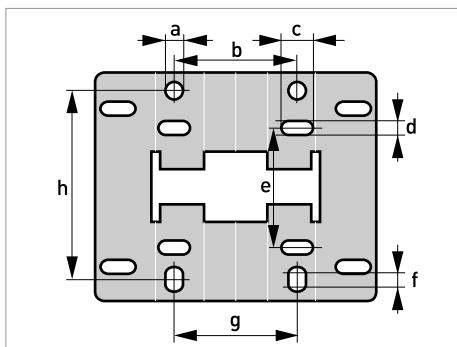

Dimensions in mm and inches

	[mm]	[inches]
a	Ø9	Ø0.4
b	64	2.5
c	16	0.6
d	6	0.2
e	63	2.5
f	4	0.2
g	64	2.5
h	98	3.85





KROHNE product overview

- Electromagnetic flowmeters
- Variable area flowmeters
- Ultrasonic flowmeters
- Mass flowmeters
- Vortex flowmeters
- Flow controllers
- Level meters
- Temperature meters
- Pressure meters
- Analysis products
- Measuring systems for the oil and gas industry
- Measuring systems for sea-going tankers

Head Office KROHNE Messtechnik GmbH & Co. KG
Ludwig-Krohne-Str. 5
D-47058 Duisburg (Germany)
Tel.: +49 (0)203 301 0
Fax: +49 (0)203 301 10389
info@krohne.de

The current list of all KROHNE contacts and addresses can be found at:
www.krohne.com

KROHNE