



IFC 300 Technical Datasheet

Signal converter for electromagnetic flowmeters

- All-round signal converter matches almost any application requirement
- Reliable measurements with extensive diagnostics of device and application
- Wide range of communication options including PROFINET



The documentation is only complete when used in combination with the relevant documentation for the flow sensor.

1	Product features	4
1.1	The versatile solution	4
1.2	Options and variants	6
1.3	Possible scope of delivery for signal converter / flow sensor	9
1.4	Measuring principle	10
2	Technical data	11
2.1	Technical data	11
2.2	Dimensions and weight	24
2.2.1	Housing	24
2.2.2	Mounting plate of field housing	25
2.2.3	Mounting plate of wall-mounted housing	25
2.3	Flow tables	26
2.4	Measuring accuracy (except TIDALFLUX 2000)	28
2.5	Measuring accuracy (only TIDALFLUX 2000)	29
3	Installation	30
3.1	Intended use	30
3.2	Installation specifications	30
3.3	Mounting of the compact version	30
3.4	Mounting the field housing, remote version	31
3.4.1	Pipe mounting	31
3.4.2	Wall mounting	32
3.5	Mounting the wall-mounted housing, remote version	33
3.5.1	Pipe mounting	33
3.5.2	Wall mounting	34
4	Electrical connections	35
4.1	Important notes on electrical connection	35
4.2	Preparing the signal and field current cables (except TIDALFLUX)	35
4.2.1	Signal cable A (type DS 300), construction	35
4.2.2	Length of signal cable A	36
4.2.3	Signal cable B (type BTS 300), construction	37
4.2.4	Length of signal cable B	38
4.3	Connecting the signal and field current cables (except TIDALFLUX)	39
4.3.1	Connection diagram for flow sensor, field housing	39
4.3.2	Connection diagram for flow sensor, wall-mounted housing	40
4.3.3	Connection diagram for flow sensor, 19" rack-mounted housing (28 TE)	41
4.3.4	Connection diagram for flow sensor, 19" rack-mounted housing (21 TE)	42

4.4 Electrical connection only for TIDALFLUX 2000	43
4.5 Connecting power - all housing variants	43
4.6 Inputs and outputs, overview	46
4.6.1 Combinations of the inputs/outputs (I/Os)	46
4.6.2 Description of the CG number	47
4.6.3 Fixed, non-alterable input/output versions.....	48
4.6.4 Alterable input/output versions.....	50
5 Notes	51

1.1 The versatile solution

The **IFC 300** is a very complete signal converter, featuring a wide range of variants and options to match almost any application requirements in process industries.

The robust and reliable signal converter is compatible with almost any flow sensor in the OPTIFLUX and WATERFLUX range. Its measurement performance is excellent even in more difficult applications like mediums with low conductivity or mediums with high solid content or entrained air, corrosive and or abrasive mediums. The signal converter is approved to a wide range of custody transfer regulations (OIML, MID).

The IFC 300 is designed according to the unified General Device Concept (GDC) that is used for the volume flow, mass flow and analysis converters. The design concept offers an uniform user interface and menu structure and also an uniform electronics suitable for various housings, uniform device and process diagnostics functions and uniform communication interfaces. This offers great time and cost benefits with regard to procurement, engineering, operation and servicing.

The **IFC 300** signal converter provides a largest variety of flowmeter and process diagnostic functions guaranteeing reliable measurements. Detection of deposits or coating on the electrodes, temperature and conductivity changes in the medium, gas bubbles or solids, and an empty pipe are good examples of process diagnostics functions. The flow velocity and volume can be read from the display or in analogue form via the current output (4...20 mA) as well as by frequency or pulse outputs. Measuring values and diagnostic information can be transmitted via field bus interfaces including HART[®], RS485 Modbus, FOUNDATION[™] Fieldbus, PROFIBUS[®] and PROFINET IO.

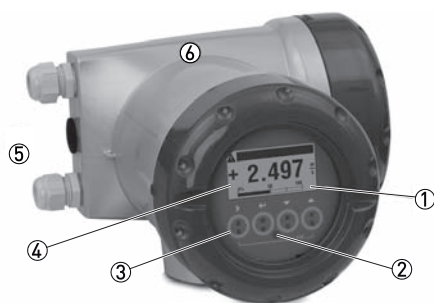

(signal converter in compact housing)

- ① Large graphic display with backlit with graphics
- ② Configuration with infrared interface for reading and writing all parameters (option)
- ③ Optical buttons (4) for operator control without opening the housing
- ④ Intuitive navigation and quick setup menu in 18 operating languages
- ⑤ Any combination of up to 4 outputs and inputs
- ⑥ Communication interfaces including HART[®], Modbus, FOUNDATION[™] Fieldbus, PROFIBUS[®] and PROFINET IO

Highlights

- For operation with complete OPTIFLUX and WATERFLUX flow sensor line
- For flow sensors over a diameter range of DN2.5...3000 / 1/10...120"
- Continuous measurement of volume flow and flow velocity
Integrated conductivity measurement, mass flow (at constant density) and coil temperature
- High measuring accuracy and long-term stability: $\pm 0.15\%$ of measured value ± 1 mm/s
- Optimal zero point stability independent from product properties
- Power supply via 100...230 VAC (standard) or 24 VDC or 24 VAC/DC (optional)
- Superior process reliability thanks to standard integrated diagnostics: testing of device functions, check for compliance with specifications and application testing
- Available inputs and outputs: Current output (including HART[®]), pulse/frequency output, status output, control input and current input
- Communication interfaces for integration into third party systems via HART[®] (as standard), Modbus, FOUNDATION[™] Fieldbus, PROFIBUS[®] and PROFINET IO
- Wide range of custody transfer approvals including OIML R 49 and R 117-1, MI-001, MI-004 and MI-005

Industries

- Chemicals
- Water & Wastewater
- Machinery
- Pulp & Paper
- Minerals & Mining
- Food & Beverage
- Oil production & Refineries
- HVAC, energy management

Applications

- Volume flow measurements, process control and monitoring, blending, batching
- Mediums with low conductivity, high solid content or entrained air
- Sudden change in pH value
- Pulsating or turbulent flows
- Abrasive sludge and slurries, pastes
- Wide range of corrosive chemicals
- (Sea)Water flow measurements in a wide range of industries
- Well water injection
- Custody transfer

1.2 Options and variants



(signal converter in compact housing)



(signal converter in field housing)



(signal converter in wall-mounted housing)



(signal converter in 19" rack-mounted housing;
option 28 TE or 21 TE)

Compact or remote housing variants

The IFC 300 signal converter is available in four housing variants, of which one compact design and three remote designs.

Next to a field housing there is a wall-mounted housing and a 19" rack mounted housing.

The wall mounted signal converter can be installed remotely for locations where the flow sensor is difficult to access, or ambient temperature conditions or vibrations prevent a compact variant.

The signal converter in the 19" built rack mounted housing is typically used in a central control room.

IFC 300 for hazardous areas

The compact and field housing versions of the IFC 300 signal converter are available in a variant suitable for hazardous areas with approvals to for example ATEX, IEC, IA, FM, CSA, NEPSI and INMETRO.

IFC 300 in stainless steel housing (option)

Whereas the standard housing material for the IFC 300 is die-cast aluminium with a polyester topcoat, the compact and the field version of the IFC 300 can optionally be ordered in a stainless steel housing. The robust housing is suitable for many applications in more harsh process environments.

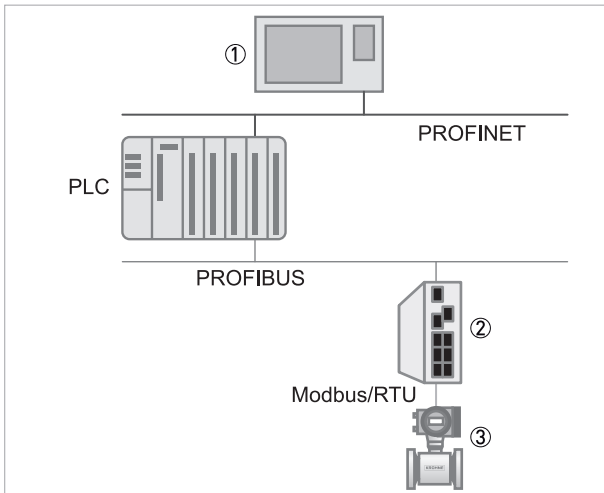

- ① Monitoring system
- ② Gateway
- ③ Flowmeter

Communication options

The basic signal converter variant covers a current output including HART[®], pulse/ frequency output, status output, control input and a current input.

The modular input/output variant allows for any combination of up to four inputs and outputs. All inputs and outputs are galvanically isolated from each other and from the rest of the electronic equipment. Inputs and outputs can be passive or active.

In addition, the electronics can be equipped with fieldbus functionality including Foundation Fieldbus, Profibus PA/DP, Modbus or PROFINET IO to enable communication to any third party system.

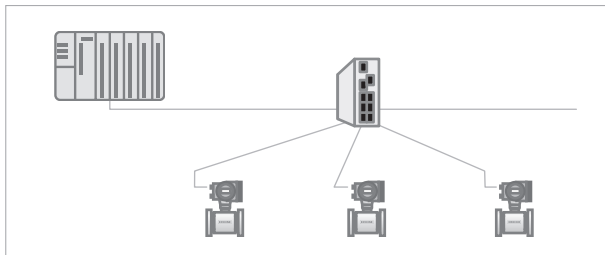

(1. point-to-point or star communication)

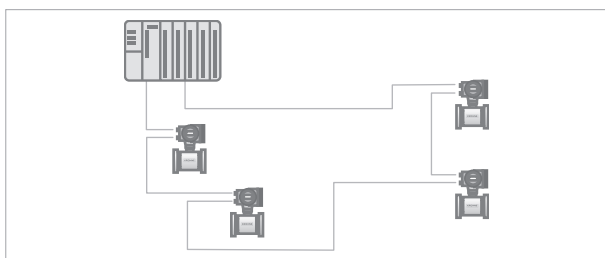

(2. ring or line communication)

New: PROFINET IO option

With PROFINET IO, real time Ethernet can be connected to IoT scenarios.

The use of existing, legacy, industry-grade devices (e.g. PROFINET flow sensors, actuators and Programmable Logic Controllers (PLC's)) enables a new architecture to be used across the Internet.

An unique network topology:

1. Working with point-to-point or star communication using a single Ethernet port and an external switch.
2. Using ring or line communication there are two Ethernet ports available controlled by an internal switch.

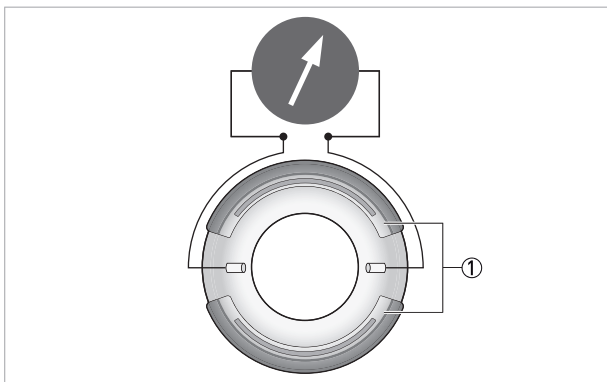

[Resistance measurement]

① Coils

Extensive diagnostics of the device and application

The primary focus of a user for a flowmeter is that it delivers reliable and robust measurements.

To achieve this all electromagnetic flowmeters are calibrated before leaving the factory.

In addition, KROHNE was one of the first to introduce extensive diagnostic features.

The IFC 300 provides a wide range diagnostic functions on the flow sensor, signal converter and process integrated in the signal converter.

The IFC 300 automatically performs an online cyclical verification to determine whether the measuring device is still within its specifications regarding accuracy and linearity.

Potential problems that may occur in the process including gas bubbles, solids, electrode corrosion, deposits on electrodes, conductivity changes, empty pipe, partial filling of the sensor, disrupted flow profiles.

External magnetic fields can be detected by the IFC 300 diagnostics features.

Diagnostic info available via local display, status outputs, Fieldbuses, Pactware or the OPTICHECK.

OPTICHECK tool for on-site verification

The OPTICHECK provides an inline health check of the device under test by an external tool.

When the tool is connected on site, it gathers measuring data to ensure that the flowmeter performs within 1% of its factory calibration.

The baseline can be historic repair data from the factory or on-site test results after performing a full verification.

A hard copy of the verification report can be printed for every flowmeter. The verification data are digitally stored.

Contact us for more information or for an on-site service visit.



[Suitcase with OPTICHECK and all cables and accessories]

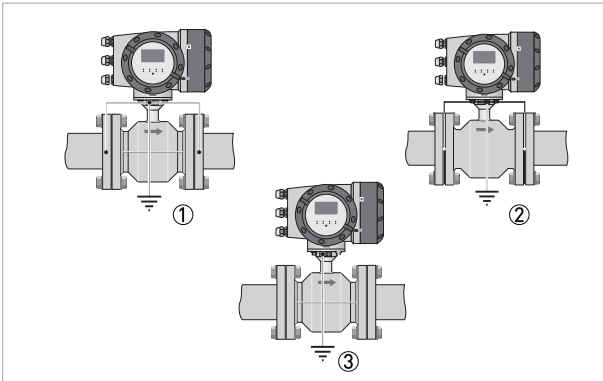

- ① Metal pipes
- ② Non metal pipes
- ③ Virtual reference option

Virtual reference option simplifies installation

Based on a special method, developed by KROHNE, called virtual reference or grounding, electromagnetic flowmeters can be installed in any type of pipeline, without grounding rings or electrodes.

The virtual reference option on the IFC 300 provides complete isolation of the signal converters input amplifier and coil power circuits.

It is ideal for applications in the water and wastewater industry where large diameters are common or in case of abrasive or corrosive application that require rings of expensive materials. In these case the costs for grounding rings can be substantial.

Virtual reference also increases safety as it decreases the number of potential leakage points.

Furthermore it is no longer necessary to select the right grounding ring (material) and reduces the risk of wrong installation of grounding rings and gaskets.

1.3 Possible scope of delivery for signal converter / flow sensor

Flow sensor	Flow sensor + signal converter IFC 300			
	Compact	Remote field housing	Remote wall-mounted housing	Remote rack-mounted housing R (28 TE) or (21 TE)
OPTIFLUX 1000	OPTIFLUX 1300 C	OPTIFLUX 1300 F	OPTIFLUX 1300 W	OPTIFLUX 1300 R
OPTIFLUX 2000	OPTIFLUX 2300 C	OPTIFLUX 2300 F	OPTIFLUX 2300 W	OPTIFLUX 2300 R
OPTIFLUX 4000	OPTIFLUX 4300 C	OPTIFLUX 4300 F	OPTIFLUX 4300 W	OPTIFLUX 4300 R
OPTIFLUX 5000	OPTIFLUX 5300 C	OPTIFLUX 5300 F	OPTIFLUX 5300 W	OPTIFLUX 5300 R
OPTIFLUX 6000	OPTIFLUX 6300 C	OPTIFLUX 6300 F	OPTIFLUX 6300 W	OPTIFLUX 6300 R
OPTIFLUX 7000	OPTIFLUX 7300 C	-	-	-
WATERFLUX 3000	WATERFLUX 3300 C	WATERFLUX 3300 F	WATERFLUX 3300 W	WATERFLUX 3300 R
TIDALFLUX 2000	-	TIDALFLUX 2300 F	-	-

1.4 Measuring principle

An electrically conductive fluid flows inside an electrically insulated pipe through a magnetic field. This magnetic field is generated by a current, flowing through a pair of field coils.

Inside of the fluid, a voltage U is generated:

$$U = v * k * B * D$$

in which:

v = mean flow velocity

k = factor correcting for geometry

B = magnetic field strength

D = inner diameter of flowmeter

The signal voltage U is picked off by electrodes and is proportional to the mean flow velocity v and thus the flow rate Q . A signal converter is used to amplify the signal voltage, filter it and convert it into signals for totalizing, recording and output processing.

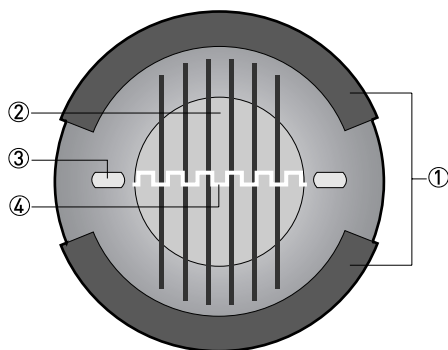

Figure 1-1: Measuring principle

- ① Field coils
- ② Magnetic field
- ③ Electrodes
- ④ Induced voltage (proportional to flow velocity)

2.1 Technical data

- *The following data is provided for general applications. If you require data that is more relevant to your specific application, please contact us or your local sales office.*
- *Additional information (certificates, special tools, software,...) and complete product documentation can be downloaded free of charge from the website (Downloadcenter).*

Measuring system

Measuring principle	Faraday's law of induction
Application range	Continuous measurement of current volume flow, flow velocity, conductivity, mass flow (at constant density), coil temperature of the flow sensor

Design

Modular design	The measuring system consists of a flow sensor and a signal converter.
Flow sensor	
OPTIFLUX 1000	DN10...150 / 3/8...6"
OPTIFLUX 2000	DN25...3000 / 1...120"
OPTIFLUX 4000	DN2.5...3000 / 1/10...120"
OPTIFLUX 5000	Flange: DN15...300 / 1/2...12" Sandwich: DN2.5...100 / 1/10...4"
OPTIFLUX 6000	DN2.5...150 / 1/10...6"
OPTIFLUX 7000	Flange: DN25...100 / 1...4" Sandwich: DN25...100 / 1...4"
	This capacitive flowmeter is only available as compact version (OPTIFLUX 7300 C).
WATERFLUX 3000	DN25...600 / 1...24"
TIDALFLUX 2000	DN200...1600 / 8...64"
	This flow sensor for measurements in partly filled pipelines is only available as a remote field housing version (TIDALFLUX 2300 F).
	With the exception of the OPTIFLUX 1000, TIDALFLUX 2000 and WATERFLUX 3000 all flow sensors are also available as Ex versions.
Signal converter	
Compact version (C)	OPTIFLUX x300 C (x = 1, 2, 4, 5, 6, 7) or WATERFLUX 3300 C
Field housing (F) - remote version	IFC 300 F
Wall-mounted housing (W) - remote version	IFC 300 W
	Compact and field housing versions are also available as Ex versions.
19" rack-mounted housing (R) - remote version	IFC 300 R

Options	
Outputs / inputs	Current output (including HART®), pulse output, frequency output and/or status output, limit switch and/or control input or current input (depending on the I/O version)
Totalizer	2 (optional 3) internal counters with a max. of 8 counter places (e.g. for counting volume and/or mass units)
Verification	Integrated verification, diagnostic functions: measuring device, process, measured value, empty pipe detection, stabilisation
Communication interfaces	HART®, Foundation Fieldbus, Profibus PA and DP, PROFINET IO, Modbus
Display and user interface	
Graphic display	LC display, backlit white.
	Size: 128 x 64 pixels, corresponds to 59 x 31 mm = 2.32" x 1.22"
	Display can be rotated in 90° increments.
	Ambient temperatures below -25°C / -13°F, may affect the readability of the display.
Operating elements	4 optical keys for operator control of the signal converter without opening the housing.
	Infrared interface for reading and writing all parameters with IR interface (option) without opening the housing.
Remote control	PACTware™ (including Device Type Manager (DTM))
	HART® Hand Held Communicator from Emerson Process
	AMS® from Emerson Process
	PDM® from Siemens
	All DTMs and drivers are available free of charge from the manufacturer's website.
Display functions	
Operating menu	Setting the parameters using 2 measured value pages, 1 status page, 1 graphics page (measured values and graphics are freely adjustable)
Language display texts (as language package)	Standard: English, French, German, Dutch, Portuguese, Swedish, Spanish, Italian
	Eastern Europe: English, Slovenian, Czech, Hungarian
	Northern Europe: English, Danish, Polish
	China: English, German, Chinese
	Russia: English, German, Russian
Units	Metric, British and US units selectable as required from lists for volume / mass flow and counting, flow velocity, electrical conductivity, temperature, pressure

Measuring accuracy

Reference conditions	Depending on the flow sensor version.
	Refer to technical data for the flow sensor.
Maximum measuring error	±0.15% of the measured value ±1 mm/s, depending on the flow sensor
	For detailed information and accuracy curves, refer to chapter "Measuring accuracy".
	Current output electronics: ±5 µA
Repeatability	±0.06% according to OIML R117 Not valid for WATERFLUX 3000, OPTIFLUX 7000 and TIDALFLUX 2000

Operating conditions

Temperature	
Process temperature	Refer to technical data for the flow sensor.
Ambient temperature	Depending on the version and combination of outputs.
	It is a good idea to protect the converter from external heat sources such as direct sunlight as higher temperatures reduce the life cycle of all electronic components.
	-40...+65°C / -40...+149°F
	Ambient temperatures below -25°C / -13°F, may affect the readability of the display.
Storage temperature	-50...+70°C / -58...+158°F
Pressure	
Medium	Refer to technical data for the flow sensor.
Ambient pressure	Atmosphere: Height up to 2000 m / 6561.7 ft
Chemical properties	
Electrical conductivity	Standard All media except for water: $\geq 1 \mu\text{S/cm}$ (also refer to the technical data for the flow sensor) Water: $\geq 20 \mu\text{S/cm}$
	TIDALFLUX 2000 All media: $\geq 50 \mu\text{S/cm}$ (also refer to the technical data for the flow sensor)
	OPTIFLUX 7000 All media except for water: $\geq 0.05 \mu\text{S/cm}$ (also refer to the technical data for the flow sensor) Water: $\geq 1 \mu\text{S/cm}$
Physical condition	Conductive, liquid media
Solid content (volume)	Can be used up to $\leq 70\%$ for OPTIFLUX flow sensors and $\leq 20\%$ for TIDALFLUX 2000 flow sensors
	The greater the solid content, the less accurate the measurements!
Gas content (volume)	Can be used up to $\leq 5\%$ for OPTIFLUX and TIDALFLUX 2000 flow sensors
	The greater the gas content, the less accurate the measurements!
Flow	For detailed information, refer to chapter "Flow tables".
Other conditions	
Ingress protection according to IEC 60529	C (compact version) & F (field housing): IP66/67 (according to NEMA 4/4X/6)
	W (wall-mounted housing): IP65/66 (according to NEMA 4/4X)
	R (19" rack-mounted housing (28 TE) or (21 TE)): IP20 (according to NEMA 1); Use: Indoor only, level of pollution 2 and relative humidity < 75%

Installation conditions

Installation	For detailed information, refer to chapter "Installation".
Inlet/outlet runs	Refer to technical data for the flow sensor.
Dimensions and weight	For detailed information refer to chapter "Dimensions and weight".

Materials

Signal converter housing	Standard
	Version C and F: die-cast aluminium (polyurethane coated)
	Version W: polyamide - polycarbonate
	Version R (28 TE): aluminium, stainless steel and aluminium sheet, partially polyester-coated
	Version R (21 TE): aluminium and aluminium sheet, partially polyester-coated
	Option
Flow sensor	For housing materials, process connections, liners, grounding electrodes and gaskets, refer to technical data for the flow sensor.

Electrical connection

General	Electrical connection is carried out in conformity with the VDE 0100 directive "Regulations for electrical power installations with line voltages up to 1000 V" or equivalent national regulations.
Power supply	Standard: 100...230 VAC (-15% / +10%), 50/60 Hz 240 VAC + 5% is included in the tolerance range.
	Option 1: 12...24 VDC (-55% / +30%) 12 VDC - 10% is included in the tolerance range.
	Option 2: 24 VAC/DC (AC: -15% / +10%, 50/60 Hz; DC: -25% / +30%) 12 V is not included in the tolerance range.
Power consumption	AC: 22 VA
	DC: 12 W
Signal cable	Only for remote versions.
	DS 300 (type A) Max. length: 600 m / 1968 ft (depending on electrical conductivity and flow sensor version)
	BTS 300 (type B) Max. length: 600 m / 1968 ft (depending on electrical conductivity and flow sensor version)
	Type LIYCY (only FM, Class 1 Div. 2) Max. length: 100 m / 328 ft (depending on electrical conductivity and flow sensor version)
Interface cable (only TIDALFLUX 2000)	Type LIYCY Max. length: 600 m / 1968 ft (3 x 0.75 mm ² shielded cable)
Cable entries (except TIDALFLUX 2000)	Standard: M20 x 1.5 (8...12 mm) for C, F and W version; Terminal strip for R-version
	Option: 1/2 NPT, PF 1/2 for C, F and W version
Cable entries (only TIDALFLUX 2000)	Standard: 2x M20 x 1.5 + 2x M16 x 1.5 EMC type
	Option: 1/2 NPT

Inputs and outputs

General	All outputs are electrically isolated from each other and from all other circuits.		
	All operating data and output values can be adjusted.		
Description of used abbreviations	U_{ext} = external voltage; R_L = load + resistance; U_0 = terminal voltage; I_{nom} = nominal current Safety limit values [Ex i]: U_i = max. input voltage; I_i = max. input current; P_i = max. input power rating; C_i = max. input capacity; L_i = max. input inductivity		
Current output			
Output data	Volume flow, mass flow, diagnostic value, flow velocity, coil temperature, conductivity		
Settings	Without HART®		
	Q = 0%: 0...15 mA; Q = 100%: 10...20 mA		
	Error identification: 3...22 mA		
	With HART®		
	Q = 0%: 4...15 mA; Q = 100%: 10...20 mA		
	Error identification: 3.5...22 mA		
Operating data	Basic I/Os	Modular I/Os	Ex i I/Os
Active	$U_{int, nom} = 24 \text{ VDC}$ $I \leq 22 \text{ mA}$ $R_L \leq 1 \text{ k}\Omega$		$U_{int, nom} = 20 \text{ VDC}$ $I \leq 22 \text{ mA}$ $R_L \leq 450 \Omega$
			$U_0 = 21 \text{ V}$ $I_0 = 90 \text{ mA}$ $P_0 = 0.5 \text{ W}$ $C_0 = 90 \text{ nF} / L_0 = 2 \text{ mH}$ $C_0 = 110 \text{ nF} / L_0 = 0.5 \text{ mH}$ Linear characteristics
Passive	$U_{ext} \leq 32 \text{ VDC}$ $I \leq 22 \text{ mA}$ $U_0 \geq 1.8 \text{ V}$ $R_L \leq (U_{ext} - U_0) / I_{max}$		$U_{ext} \leq 32 \text{ VDC}$ $I \leq 22 \text{ mA}$ $U_0 \geq 4 \text{ V}$ $R_L \leq (U_{ext} - U_0) / I_{max}$
			$U_i = 30 \text{ V}$ $I_i = 100 \text{ mA}$ $P_i = 1 \text{ W}$ $C_i = 10 \text{ nF}$ $L_i \sim 0 \text{ mH}$

HART®			
Description	HART® protocol via active and passive current output		
	HART® version: V5		
	Universal HART® parameter: completely integrated		
Load	≥ 230 Ω at HART® test point; Note maximum load for current output!		
Multi-Drop operation	Yes, current output = 4 mA		
	Multi-Drop address adjustable in operation menu 1...15		
Device drivers	Available for FC 375/475, AMS, PDM, FDT/DTM		
Registration (HART Communication Foundation)	Yes		
Pulse output or frequency output			
Output data	Pulse output: volume flow, mass flow		
	Frequency output: volume flow, mass flow, diagnostic value, flow velocity, coil temperature, conductivity		
Function	Adjustable as pulse or frequency output		
Pulse rate/frequency	Adjustable final value: 0.01...10000 pulse/s or Hz		
Settings	Pulses per volume or mass unit or max. frequency for 100% flow		
	Pulse width: setting automatic, symmetric or fixed (0.05...2000 ms)		
Operating data	Basic I/Os	Modular I/Os	Ex i I/Os
Active	-	$U_{nom} = 24 \text{ VDC}$ f_{max} in operating menu set to $f_{max} \leq 100 \text{ Hz}$: $I \leq 20 \text{ mA}$ open: $I \leq 0.05 \text{ mA}$ closed: $U_{0, nom} = 24 \text{ V}$ at $I = 20 \text{ mA}$	-
		f_{max} in operating menu set to $100 \text{ Hz} < f_{max} \leq 10 \text{ kHz}$: $I \leq 20 \text{ mA}$ open: $I \leq 0.05 \text{ mA}$ closed: $U_{0, nom} = 22.5 \text{ V}$ at $I = 1 \text{ mA}$ $U_{0, nom} = 21.5 \text{ V}$ at $I = 10 \text{ mA}$ $U_{0, nom} = 19 \text{ V}$ at $I = 20 \text{ mA}$	

Operating data	Basic I/Os	Modular I/Os	Ex i I/Os
Passive	$U_{\text{ext}} \leq 32 \text{ VDC}$ f_{max} in operating menu set to $f_{\text{max}} \leq 100 \text{ Hz}$: $I \leq 100 \text{ mA}$ $R_{L, \text{max}} = 47 \text{ k}\Omega$ $R_{L, \text{min}} = (U_{\text{ext}} - U_0) / I_{\text{max}}$ open: $I \leq 0.05 \text{ mA}$ at $U_{\text{ext}} = 32 \text{ VDC}$ closed: $U_{0, \text{max}} = 0.2 \text{ V}$ at $I \leq 10 \text{ mA}$ $U_{0, \text{max}} = 2 \text{ V}$ at $I \leq 100 \text{ mA}$		-
	f_{max} in operating menu set to $100 \text{ Hz} < f_{\text{max}} \leq 10 \text{ kHz}$: $I \leq 20 \text{ mA}$ $R_{L, \text{max}} = 47 \text{ k}\Omega$ $R_{L, \text{min}} = (U_{\text{ext}} - U_0) / I_{\text{max}}$ open: $I \leq 0.05 \text{ mA}$ at $U_{\text{ext}} = 32 \text{ VDC}$ closed: $U_{0, \text{max}} = 1.5 \text{ V}$ at $I \leq 1 \text{ mA}$ $U_{0, \text{max}} = 2.5 \text{ V}$ at $I \leq 10 \text{ mA}$ $U_{0, \text{max}} = 5.0 \text{ V}$ at $I \leq 20 \text{ mA}$		
NAMUR	-	Passive to EN 60947-5-6 open: $I_{\text{nom}} = 0.6 \text{ mA}$ closed: $I_{\text{nom}} = 3.8 \text{ mA}$	Passive to EN 60947-5-6 open: $I_{\text{nom}} = 0.43 \text{ mA}$ closed: $I_{\text{nom}} = 4.5 \text{ mA}$ $U_i = 30 \text{ V}$ $I_i = 100 \text{ mA}$ $P_i = 1 \text{ W}$ $C_i = 10 \text{ nF}$ $L_i \sim 0 \text{ mH}$
Low flow cut-off			
Function	Switching point and hysteresis separately adjustable for each output, counter and the display		
Switching point	Current output, frequency output: 0...20%; set in increments of 0.1 Pulse output: Unit is volume flow or mass flow and not limited		
Hysteresis			
Time constant			
Function	The time constant corresponds to the elapsed time until 63% of the end value has been reached according to a step function.		
Settings	Set in increments of 0.1 seconds.		
	0...100 seconds		

Status output / limit switch			
Function and settings	Adjustable as automatic measuring range conversion, display of flow direction, counter overflow, error, switching point or empty pipe detection		
	Valve control with activated dosing function		
	Status and/or control: ON or OFF		
Operating data	Basic I/Os	Modular I/Os	Ex i I/Os
Active	-	$U_{int} = 24 \text{ VDC}$ $I \leq 20 \text{ mA}$ open: $I \leq 0.05 \text{ mA}$ closed: $U_{0, nom} = 24 \text{ V}$ at $I = 20 \text{ mA}$	-
Passive	$U_{ext} \leq 32 \text{ VDC}$ $I \leq 100 \text{ mA}$ $R_{L, max} = 47 \text{ k}\Omega$ $R_{L, min} = (U_{ext} - U_0) / I_{max}$ open: $I \leq 0.05 \text{ mA}$ at $U_{ext} = 32 \text{ VDC}$ closed: $U_{0, max} = 0.2 \text{ V}$ at $I \leq 10 \text{ mA}$ $U_{0, max} = 2 \text{ V}$ at $I \leq 100 \text{ mA}$	$U_{ext} = 32 \text{ VDC}$ $I \leq 100 \text{ mA}$ $R_{L, max} = 47 \text{ k}\Omega$ $R_{L, min} = (U_{ext} - U_0) / I_{max}$ open: $I \leq 0.05 \text{ mA}$ at $U_{ext} = 32 \text{ VDC}$ closed: $U_{0, max} = 0.2 \text{ V}$ at $I \leq 10 \text{ mA}$ $U_{0, max} = 2 \text{ V}$ at $I \leq 100 \text{ mA}$	-
NAMUR	-	Passive to EN 60947-5-6 open: $I_{nom} = 0.6 \text{ mA}$ closed: $I_{nom} = 3.8 \text{ mA}$	Passive to EN 60947-5-6 open: $I_{nom} = 0.43 \text{ mA}$ closed: $I_{nom} = 4.5 \text{ mA}$ $U_i = 30 \text{ V}$ $I_i = 100 \text{ mA}$ $P_i = 1 \text{ W}$ $C_i = 10 \text{ nF}$ $L_i = 0 \text{ mH}$

Control input			
Function	Hold value of the outputs (e.g. for cleaning work), set value of the outputs to "zero", counter and error reset, range change.		
	Start of dosing when dosing function is activated.		
Operating data	Basic I/Os	Modular I/Os	Ex i I/Os
Active	-	$U_{int} = 24 \text{ VDC}$ Ext. contact open: $U_{0, nom} = 22 \text{ V}$ Ext. contact closed: $I_{nom} = 4 \text{ mA}$ Contact closed (on): $U_0 \geq 12 \text{ V}$ at $I_{nom} = 1.9 \text{ mA}$ Contact open (off): $U_0 \leq 10 \text{ V}$ at $I_{nom} = 1.9 \text{ mA}$	-
Passive	$8 \text{ V} \leq U_{ext} \leq 32 \text{ VDC}$ $I_{max} = 6.5 \text{ mA}$ at $U_{ext} \leq 24 \text{ VDC}$ $I_{max} = 8.2 \text{ mA}$ at $U_{ext} \leq 32 \text{ VDC}$ Contact closed (on): $U_0 \geq 8 \text{ V}$ at $I_{nom} = 2.8 \text{ mA}$ Contact open (off): $U_0 \leq 2.5 \text{ V}$ at $I_{nom} = 0.4 \text{ mA}$	$3 \text{ V} \leq U_{ext} \leq 32 \text{ VDC}$ $I_{max} = 9.5 \text{ mA}$ at $U_{ext} \leq 24 \text{ V}$ $I_{max} = 9.5 \text{ mA}$ at $U_{ext} \leq 32 \text{ V}$ Contact closed (on): $U_0 \geq 3 \text{ V}$ at $I_{nom} = 1.9 \text{ mA}$ Contact open (off): $U_0 \leq 2.5 \text{ V}$ at $I_{nom} = 1.9 \text{ mA}$	$U_{ext} \leq 32 \text{ VDC}$ $I \leq 6 \text{ mA}$ at $U_{ext} = 24 \text{ V}$ $I \leq 6.6 \text{ mA}$ at $U_{ext} = 32 \text{ V}$ On: $U_0 \geq 5.5 \text{ V}$ at $I \geq 4 \text{ mA}$ Off: $U_0 \leq 3.5 \text{ V}$ at $I \leq 0.5 \text{ mA}$ $U_i = 30 \text{ V}$ $I_i = 100 \text{ mA}$ $P_i = 1 \text{ W}$ $C_i = 10 \text{ nF}$ $L_i = 0 \text{ mH}$
NAMUR	-	Active to EN 60947-5-6 Terminals open: $U_{0, nom} = 8.7 \text{ V}$ Contact closed (on): $U_{0, nom} = 6.3 \text{ V}$ at $I_{nom} > 1.9 \text{ mA}$ Contact open (off): $U_{0, nom} = 6.3 \text{ V}$ at $I_{nom} < 1.9 \text{ mA}$ Detection of cable break: $U_0 \geq 8.1 \text{ V}$ at $I \leq 0.1 \text{ mA}$ Detection of cable short circuit: $U_0 \leq 1.2 \text{ V}$ at $I \geq 6.7 \text{ mA}$	-

Current input			
Function	A connected external sensor delivers the values (temperature, pressure or current) to the current input.		
Operating data	Basic I/Os	Modular I/Os	Ex i I/Os
Active	-	$U_{\text{int, nom}} = 24 \text{ VDC}$ $I \leq 22 \text{ mA}$ $I_{\text{max}} \leq 26 \text{ mA}$ (electronically limited) $U_{0, \text{min}} = 19 \text{ V at } I \leq 22 \text{ mA}$ No HART®	$U_{\text{int, nom}} = 20 \text{ VDC}$ $I \leq 22 \text{ mA}$ $U_{0, \text{min}} = 14 \text{ V at } I \leq 22 \text{ mA}$ No HART®
			$U_0 = 24.5 \text{ V}$ $I_0 = 99 \text{ mA}$ $P_0 = 0.6 \text{ W}$ $C_0 = 75 \text{ nF} / L_0 = 0.5 \text{ mH}$ No HART®
Passive	-	$U_{\text{ext}} \leq 32 \text{ VDC}$ $I \leq 22 \text{ mA}$ $I_{\text{max}} \leq 26 \text{ mA}$ (electronically limited) $U_{0, \text{max}} = 5 \text{ V at } I \leq 22 \text{ mA}$ No HART®	$U_{\text{ext}} \leq 32 \text{ VDC}$ $I \leq 22 \text{ mA}$ $U_{0, \text{max}} = 4 \text{ V at } I \leq 22 \text{ mA}$ No HART®
			$U_i = 30 \text{ V}$ $I_i = 100 \text{ mA}$ $P_i = 1 \text{ W}$ $C_i = 10 \text{ nF}$ $L_i = 0 \text{ mH}$ No HART®

PROFIBUS DP	
Description	Galvanically isolated according to IEC 61158
	Profile version: 3.01
	Automatic data transmission rate recognition (max. 12 MBaud)
	Bus address adjustable via local display at the measuring device
Function blocks	5 x analogue input, 3 x totaliser
Output data	Volume flow, mass flow, volume counter 1 + 2, mass counter, velocity, coil temperature, conductivity
PROFIBUS PA	
Description	Galvanically isolated according to IEC 61158
	Profile version: 3.01
	Current consumption: 10.5 mA
	Permissible bus voltage: 9...32 V; in Ex application: 9...24 V
	Bus interface with integrated reverse polarity protection
	Typical error current FDE (Fault Disconnection Electronic): 4.3 mA
	Bus address adjustable via local display at the measuring device
Function blocks	5 x analogue input, 3 x totaliser
Output data	Volume flow, mass flow, volume counter 1 + 2, mass counter, velocity, coil temperature, conductivity
FOUNDATION Fieldbus	
Description	Galvanically isolated according to IEC 61158
	Current consumption: 10.5 mA
	Permissible bus voltage: 9...32 V; in Ex application: 9...24 V
	Bus interface with integrated reverse polarity protection
	Link Master function (LM) supported
	Tested with Interoperable Test Kit (ITK) version 5.1
Function blocks	3 x analogue Input, 2 x integrator, 1 x PID
Output data	Volume flow, mass flow, velocity, coil temperature, conductivity, electronics temperature
Modbus	
Description	Modbus RTU, Master / Slave, RS485
Address range	1...247
Supported function codes	03, 04, 16
Broadcast	Supported with function code 16
Supported Baud rate	1200, 2400, 4800, 9600, 19200, 38400, 57600, 115200 Baud
PROFINET IO	
Description	PROFINET IO is an Ethernet based communications protocol.
	The device features two Ethernet ports with an integrated industrial Ethernet switch.
	The Ethernet standard 100BASE-TX is supported.
	Additionally, the PHYs support the following features: - Auto negotiation - Auto crossover - Auto polarity
Output data	Volume flow, mass flow, volume counter, mass counter, velocity, coil temperature, conductivity

Approvals and certificates

CE	This device fulfils the statutory requirements of the relevant EU directives. The manufacturer certifies successful testing of the product by applying the CE mark.
	For full information of the EU directives & standards and the approved certifications, please refer to the CE declaration or the manufacturer website.
Non-Ex	Standard
Hazardous areas	
Option (only C version)	
ATEX	OPTIFLUX 2300 C / OPTIFLUX 4300 C: II 2(1)G Ex d e [ia Ga] mb IIC T6...T3 Gb; II 2(1)G Ex d e [ia Ga] IIC T6...T3 Gb; II 2(1)G Ex d e [ia Ga] IIC T6...T3 Gb; II 2D Ex tb IIIC T150°C Db; IP66/67
	OPTIFLUX 5300 C: II 2(1)GD; II 2GD EEx d[ia] IIC T6...T3; EEx de [ia] IIC T6...T3; EEx dme [ia] IIC T6...T3, T85°C...T150°C
	OPTIFLUX 6300 C: II 2(1)GD; II 2GD EEx d mb e [ia] IIC T6...T3 T150°C
	OPTIFLUX 7300 C: II 2G Ex d IIC T6...T4; Ex d e IIC T6...T4; Ex d mb IIC T6...T4; Ex d e mb IIC T6...T4; II 2(1)G Ex d [ia] IIC T6...T4; Ex de [ia] IIC T6...T4; Ex d mb [ia] IIC T6...T4; Ex d e mb [ia] IIC T6...T4; II 2D Ex tD A21 IP67 T115
IECEX	OPTIFLUX 2300 C / OPTIFLUX 4300 C: Ex d e [ia Ga] mb IIC T6...T3 Gb; Ex d e [ia Ga] IIC T6...T3 Gb; Ex d e [ia Ga] q IIC T5 Gb; Ex d e [ia Ga] mb IIC T6...T3 Gb; Ex tb IIIC T150°C Db
NEPSI	OPTIFLUX 2300 C / OPTIFLUX 4300 C: Ex d e ia mb [ia Ga] IIC T3...T6 Gb; Ex d e ia [ia Ga] IIC T3...T6 Gb; Ex d e ia q [ia Ga] IIC T3...T6 Gb; Ex d e ia [ia Ga] IIC T3...T6 Gb; Ex tb IIIC T150 IP66/67
	OPTIFLUX 5300 C: Ex d e ia [ia] mb IIC T3...T6 Gb; Ex d e ia [ia] IIC T3...T6 Gb
IA	OPTIFLUX 2300 C / OPTIFLUX 4300 C: Ex dme [ia] IIC; Ex dqe [ia] IIC T6...T3; DIP A21 T80°C...T150°C
	OPTIFLUX 5300 C: Ex d [ia] IIC T6...T3; Ex de [ia] IIC T6...T3; Ex dme [ia] T6...T3; Ex de [ia] mb IIC T6...T3
	OPTIFLUX 6300 C: Ex d mb e [ia] IIC T6...T3
INMETRO	OPTIFLUX 2300 C / OPTIFLUX 4300 C: Ex de [ia Ga] IIC T6...T3 Gb; Ex de [ia Ga] mb IIC T6...T3 Gb; Ex de [ia Ga] q IIC T6...T3 Gb; Ex de [ia Ga] q IIC T5...T3 Gb; Ex tb IIIC T150°C Db
	-40°C < T _a < +65°C (aluminum housing); IP66
	-40°C < T _a < +65°C (stainless steel housing); IP66/67
Option (only F version (except TIDALFLUX 2000))	
ATEX	II 2G Ex de [ia] IIC T6 Gb; II 2(1)G Ex de [ia] IIC T6 Gb; II 2D Ex tb IIIC T85°C Db IP66/67
IECEX	Ex de [ia Ga] IIC T6 Gb; Ex tb IIIC T85°C Db
NEPSI	Ex de [ia Ga] IIC T6 Gb; Ex tb IIIC T85°C IP66/67
IA	Ex de [ia] IIC T6
INMETRO	Ex de [ia Ga] IIC T6 Gb; Ex tb [ia Da] IIIC T85°C Db IP66/67
	-40°C < T _a < +65°C (aluminum housing)
	-40°C < T _a < +65°C (stainless steel housing)

Option (only TIDALFLUX 2000 F)	
ATEX	Signal converter: II 2G Ex de [ia] IIC T6 Gb; II 2(1)G Ex de [ia] [ia Ga] IIC T6 Gb
	Flow sensor: II 2G Ex de ia [ia] IIC T6 Gb; II 2G Ex de ia q [ia] IIC T6 Gb
IECEx	Ex de [ia] IIC T6 Gb (signal converter); Ex de [ia] [ia Ga] IIC T6 Gb (signal converter with Ex i I/O)
	Ex de ia [ia] IIC T6 Gb (Ex e flow sensor DN350...DN1800)
	Ex de ia q [ia] IIC T6 Gb (Ex q flow sensor DN200...DN300)
NEPSI	Ex d T4...T6 Gb, Ex de IIC T4...T6 Gb; Ex d [ia Ga] IIC T4...T6 Gb; Ex de [ia Ga] IIC T4...T6 Gb; Ex d mb IIC T4...T6 Gb; Ex de mb IIC T4...T6 Gb; Ex d mb [ia Ga] IIC T4...T6 Gb; Ex de mb [ia Ga] IIC T4...T6 Gb; DIP A21 T115°C IP67
Option (only C and F version (except TIDALFLUX 2000))	
FM / CSA	Class I, Div. 2, Group A, B, C and D
	Class II, Div. 2, Group F and G
Custody transfer (except TIDALFLUX 2000 & OPTIFLUX 7300 C)	
None	Standard
Option	Cold drinking water (OIML R 49, KIWA K618, MI-001); liquids other than water (OIML R 117-1, MI-005)
VdS (only OPTIFLUX 2300 C, F and W)	
VdS	Use in fire and safety equipment
	Only valid for nominal diameters DN25...250 / 1...10"
Other standards and approvals	
Vibration resistance	Tested according to IEC 60068-2-64
NAMUR	NE 21, NE 43, NE 53

2.2 Dimensions and weight

2.2.1 Housing

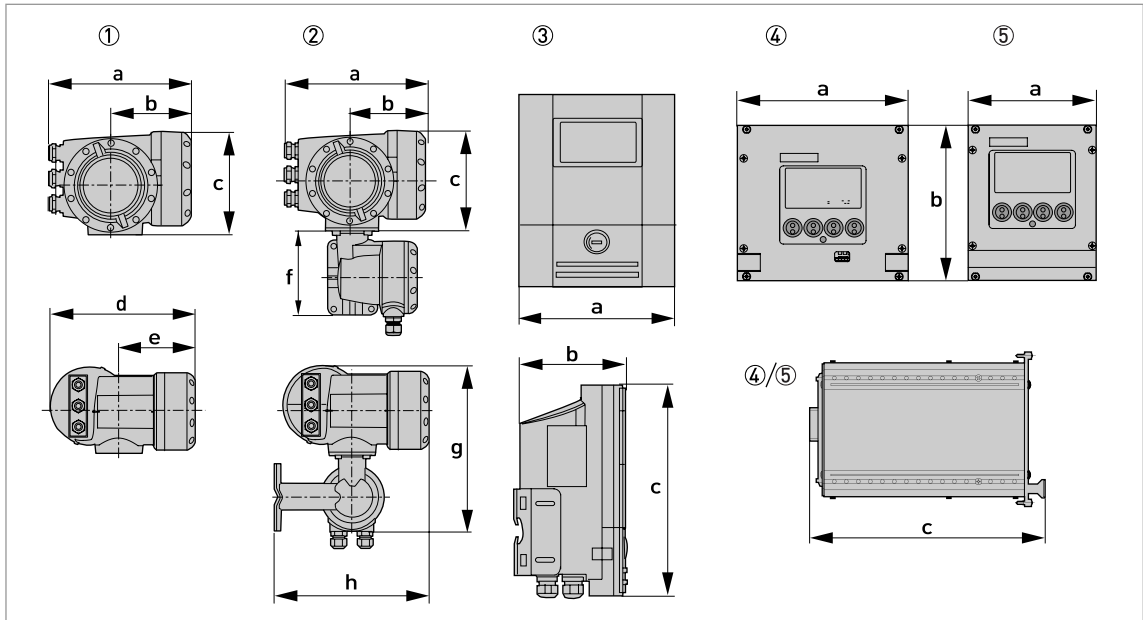

Figure 2-1: Dimensions of housing

- ① Compact version (C)
- ② Field housing (F) - remote version
- ③ Wall-mounted housing (W) - remote version
- ④ 19" rack-mounted housing 28 TE (R) - remote version
- ⑤ 19" rack-mounted housing 21 TE (R) - remote version

Version	Dimensions [mm]							Weight [kg]
	a	b	c	d	e	g	h	
C	202	120	155	260	137	-	-	4.2
F	202	120	155	-	-	295.8	277	5.7
W	198	138	299	-	-	-	-	2.4
R	142 (28 TE)	129 (3 HE)	195	-	-	-	-	1.2
	107 (21 TE)	129 (3 HE)	190	-	-	-	-	0.98

Table 2-1: Dimensions and weight in mm and kg

Version	Dimensions [inch]							Weight [lb]
	a	b	c	d	e	g	h	
C	7.75	4.75	6.10	10.20	5.40	-	-	9.30
F	7.75	4.75	6.10	-	-	11.60	10.90	12.60
W	7.80	5.40	11.80	-	-	-	-	5.30
R	5.59 (28 TE)	5.08 (3 HE)	7.68	-	-	-	-	2.65
	4.21 (21 TE)	5.08 (3 HE)	7.48	-	-	-	-	2.16

Table 2-2: Dimensions and weight in inch and lb

2.2.2 Mounting plate of field housing

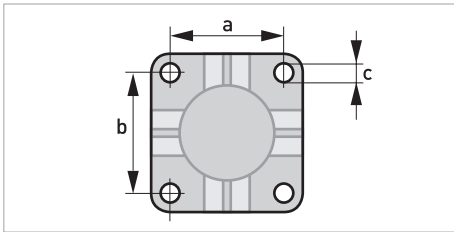

Figure 2-2: Dimensions for mounting plate of field housing

	[mm]	[inch]
a	72	2.8
b	72	2.8
c	Ø9	Ø0.4

Table 2-3: Dimensions in mm and inch

2.2.3 Mounting plate of wall-mounted housing

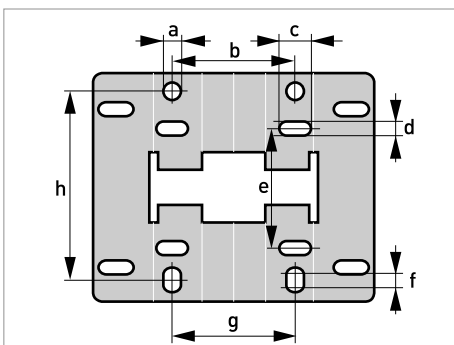

Figure 2-3: Dimensions of mounting plate of wall-mounted housing

	[mm]	[inch]
a	Ø9	Ø0.4
b	64	2.5
c	16	0.6
d	6	0.2
e	63	2.5
f	13	0.5
g	64	2.5
h	98	3.85

Table 2-4: Dimensions in mm and inch

2.3 Flow tables

Flow rate in m/s and m³/h

v [m/s]	Q _{100%} in m ³ /h			
	0.3	1	3	12
DN [mm]	Minimum flow	Nominal flow		Maximum flow
2.5	0.005	0.02	0.05	0.21
4	0.01	0.05	0.14	0.54
6	0.03	0.10	0.31	1.22
10	0.08	0.28	0.85	3.39
15	0.19	0.64	1.91	7.63
20	0.34	1.13	3.39	13.57
25	0.53	1.77	5.30	21.21
32	0.87	2.90	8.69	34.74
40	1.36	4.52	13.57	54.29
50	2.12	7.07	21.21	84.82
65	3.58	11.95	35.84	143.35
80	5.43	18.10	54.29	217.15
100	8.48	28.27	84.82	339.29
125	13.25	44.18	132.54	530.15
150	19.09	63.62	190.85	763.40
200	33.93	113.10	339.30	1357.20
250	53.01	176.71	530.13	2120.52
300	76.34	254.47	763.41	3053.64
350	103.91	346.36	1039.08	4156.32
400	135.72	452.39	1357.17	5428.68
450	171.77	572.51	1717.65	6870.60
500	212.06	706.86	2120.58	8482.32
600	305.37	1017.90	3053.70	12214.80
700	415.62	1385.40	4156.20	16624.80
800	542.88	1809.60	5428.80	21715.20
900	687.06	2290.20	6870.60	27482.40
1000	848.22	2827.40	8482.20	33928.80
1200	1221.45	3421.20	12214.50	48858.00
1400	1433.52	4778.40	14335.20	57340.80
1600	2171.46	7238.20	21714.60	86858.40
1800	2748.27	9160.9	27482.70	109930.80
2000	3393.00	11310.00	33930.00	135720.00
2200	4105.50	13685.00	41055.00	164220.00
2400	4885.80	16286.00	48858.00	195432.00
2600	5733.90	19113.00	57339.00	229356.00
2800	6650.10	22167.00	66501.00	266004.00
3000	7634.10	25447.00	76341.00	305364.00

Flow rate in ft/s and US gallons/min

v [ft/s]	Q ₁₀₀ % in US gallons/min			
	1	3.3	10	40
DN [inch]	Minimum flow	Nominal flow		Maximum flow
1/10	0.02	0.09	0.23	0.93
1/8	0.06	0.22	0.60	2.39
1/4	0.13	0.44	1.34	5.38
3/8	0.37	1.23	3.73	14.94
1/2	0.84	2.82	8.40	33.61
3/4	1.49	4.98	14.94	59.76
1	2.33	7.79	23.34	93.36
1.25	3.82	12.77	38.24	152.97
1.5	5.98	19.90	59.75	239.02
2	9.34	31.13	93.37	373.47
2.5	15.78	52.61	159.79	631.16
3	23.90	79.69	239.02	956.09
4	37.35	124.47	373.46	1493.84
5	58.35	194.48	583.24	2334.17
6	84.03	279.97	840.29	3361.17
8	149.39	497.92	1493.29	5975.57
10	233.41	777.96	2334.09	9336.37
12	336.12	1120.29	3361.19	13444.77
14	457.59	1525.15	4574.93	18299.73
16	597.54	1991.60	5975.44	23901.76
18	756.26	2520.61	7562.58	30250.34
20	933.86	3112.56	9336.63	37346.53
24	1344.50	4481.22	13445.04	53780.15
28	1829.92	6099.12	18299.20	73196.79
32	2390.23	7966.64	23902.29	95609.15
36	3025.03	10082.42	30250.34	121001.37
40	3734.50	12447.09	37346.00	149384.01
48	5377.88	17924.47	53778.83	215115.30
56	6311.60	21038.46	63115.99	252463.94
64	9560.65	31868.51	95606.51	382426.03
72	12100.27	40333.83	121002.69	484010.75
80	14938.92	49795.90	149389.29	597557.18
88	18075.97	60252.63	180759.73	723038.90
96	21511.53	71704.38	215115.30	860461.20
104	25245.60	84151.16	252456.02	1009824.08
112	29279.51	97597.39	292795.09	1171180.37
120	33611.93	112038.64	336119.31	1344477.23

2.4 Measuring accuracy (except TIDALFLUX 2000)

Every electromagnetic flowmeter is calibrated by direct volume comparison. The wet calibration validates the performance of the flowmeter under reference conditions against accuracy limits.

The accuracy limits of electromagnetic flowmeters are typically the result of the combined effect of linearity, zero point stability and calibration uncertainty.

Reference conditions

- Medium: water
- Temperature: +5...+35°C / +41...+95°F
- Operating pressure: 0.1...5 barg / 1.5...72.5 psig
- Inlet section: ≥ 5 DN; outlet section: ≥ 2 DN

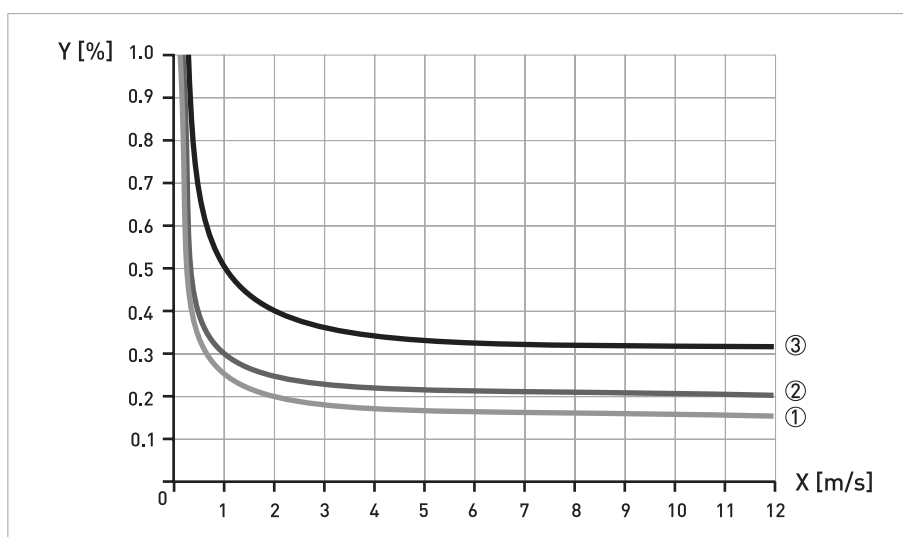

Figure 2-4: Measuring accuracy

X [m/s]: flow velocity

Y [%]: deviation from the actual measured value (mv)

	DN [mm]	DN [inch]	Accuracy	Curve
OPTIFLUX 5300	10...100	3/8...4	0.15% of mv + 1 mm/s	①
	150...300	6...12	0.2% of mv + 1 mm/s	②
OPTIFLUX 2300 / 4300 / 6300	10...1600	3/8...80	0.2% of mv + 1 mm/s	②
OPTIFLUX 1300	10...150	3/8...6	0.3% of mv + 2 mm/s	③
OPTIFLUX 2300 / 4300	>1600	>64	0.3% of mv + 2 mm/s	③
OPTIFLUX 4300 / 5300 / 6300	<10	<3/8	0.3% of mv + 2 mm/s	③
OPTIFLUX 7300	25...100	1...4	$v \geq 1 \text{ m/s} / 3.3 \text{ ft/s}$: $\pm 0.5\% \text{ of mv}$	-
			$v < 1 \text{ m/s} / 3.3 \text{ ft/s}$: $\pm 0.5\% \text{ of mv} + 5 \text{ mm/s}$	
WATERFLUX 3300	25...300	1...12	0.2% of mv + 1 mm/s	②
	350...600	14...24	0.4% of mv + 1 mm/s	-

2.5 Measuring accuracy (only TIDALFLUX 2000)

The measuring accuracy for partly filled pipes and completely filled pipes are different. In these graphs it is assumed that the velocity at full scale value is at least 1 m/s (is also the standard value for calibration, since it will result in the most accurate measurements).

Partly filled:

- $v @ \text{Full Scale} \geq 1 \text{ m/s} / 3.3 \text{ ft/s} : \leq 1\% \text{ of Full Scale}$

Fully filled:

- $v \geq 1 \text{ m/s} / 3.3 \text{ ft/s} : \leq 1\% \text{ of measured value}$
- $v < 1 \text{ m/s} / 3.3 \text{ ft/s} : \leq 0.5\% \text{ of measured value} + 5 \text{ mm/s} / 0.2 \text{ inch/s}$ (see following graph)

Fully filled pipes

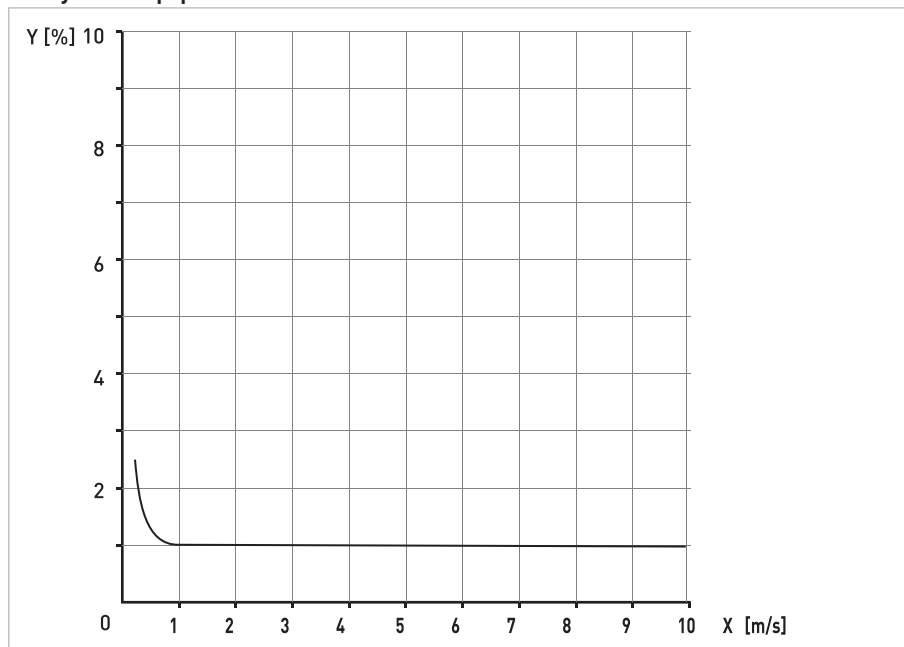

Figure 2-5: Maximum measuring error of measured value (=Y).

3.1 Intended use

The electromagnetic flowmeters are designed exclusively to measure the flow and conductivity of electrically conductive, liquid media.

For devices used in hazardous areas, additional safety notes apply; please refer to the Ex documentation.

If the device is not used according to the operating conditions (refer to chapter "Technical data"), the intended protection could be affected.

This device is a Group 1, Class A device as specified within CISPR11:2009. It is intended for use in industrial environment. There may be potential difficulties in ensuring electromagnetic compatibility in other environments, due to conducted as well as radiated disturbances.

3.2 Installation specifications

The following precautions must be taken to ensure reliable installation.

- *Make sure that there is adequate space to the sides.*
- *The device must not be heated by radiated heat (e.g. exposure to the sun) to an electronics housing surface temperature above the maximum permissible ambient temperature. If it is necessary to prevent damage from heat sources, a heat protection (e.g. sun shade) has to be installed.*
- *Signal converters installed in control cabinets require adequate cooling, e.g. by fan or heat exchanger.*
- *Do not expose the signal converter to intense vibrations. The measuring devices are tested for a vibration level as described in the chapter "Technical data".*

3.3 Mounting of the compact version

Turning the housing of the compact version is not permitted.

The signal converter is mounted directly on the flow sensor. For installation of the flowmeter, please observe the instructions in the supplied product documentation for the flow sensor.

3.4 Mounting the field housing, remote version

Remarks for sanitary applications

- *To prevent contamination and dirt deposits behind the mounting plate, a cover plug must be installed between the wall and the mounting plate.*
- *Pipe mounting is not suitable for sanitary applications!*

Assembly materials and tools are not part of the delivery. Use the assembly materials and tools in compliance with the applicable occupational health and safety directives.

3.4.1 Pipe mounting

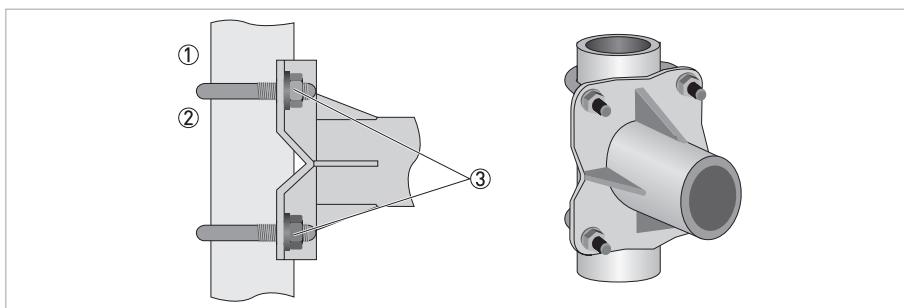

Figure 3-1: Pipe mounting of the field housing

- ① Fix the signal converter to the pipe.
- ② Fasten the signal converter using standard U-bolts and washers.
- ③ Tighten the nuts.

3.4.2 Wall mounting

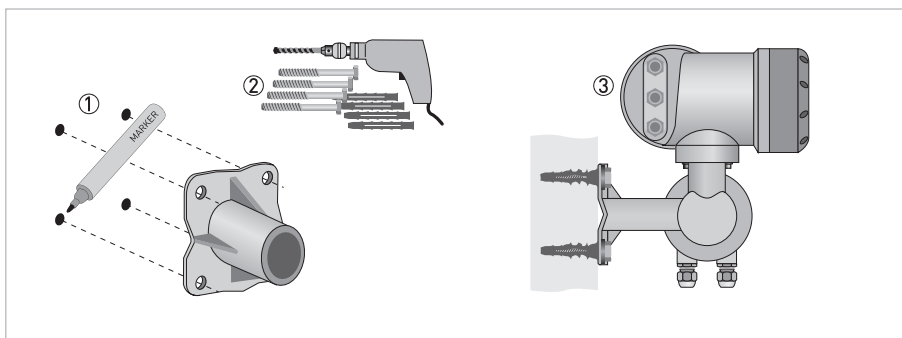

Figure 3-2: Wall mounting of the field housing

- ① Prepare the holes with the aid of the mounting plate. For further information refer to *Mounting plate of field housing* on page 25.
- ② Fasten the mounting plate securely to the wall.
- ③ Screw the signal converter to the mounting plate with the nuts and washers.

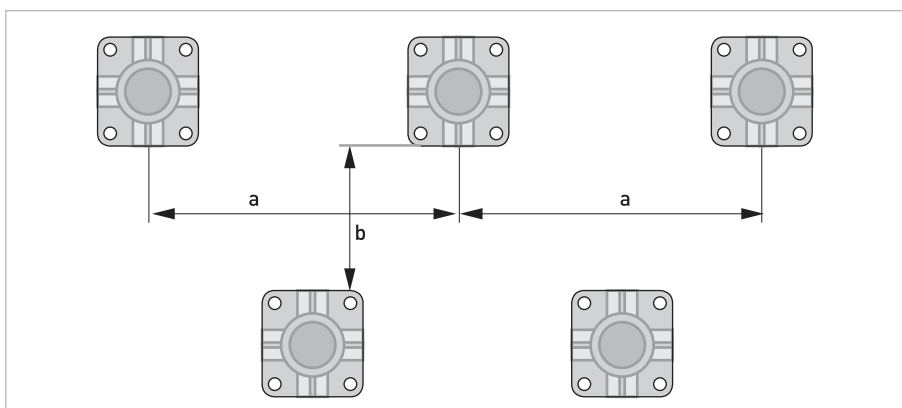

Figure 3-3: Mounting multiple devices next to each other

$a \geq 600 \text{ mm} / 23.6''$

$b \geq 250 \text{ mm} / 9.8''$

3.5 Mounting the wall-mounted housing, remote version

Assembly materials and tools are not part of the delivery. Use the assembly materials and tools in compliance with the applicable occupational health and safety directives.

3.5.1 Pipe mounting

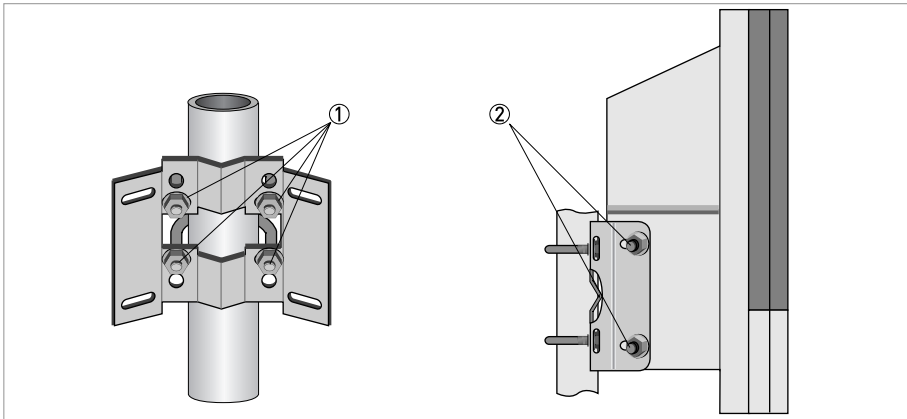

Figure 3-4: Pipe mounting of the wall-mounted housing

- ① Fasten the mounting plate to the pipe with standard U-bolts, washers and fastening nuts.
- ② Screw the signal converter to the mounting plate with the nuts and washers.

3.5.2 Wall mounting

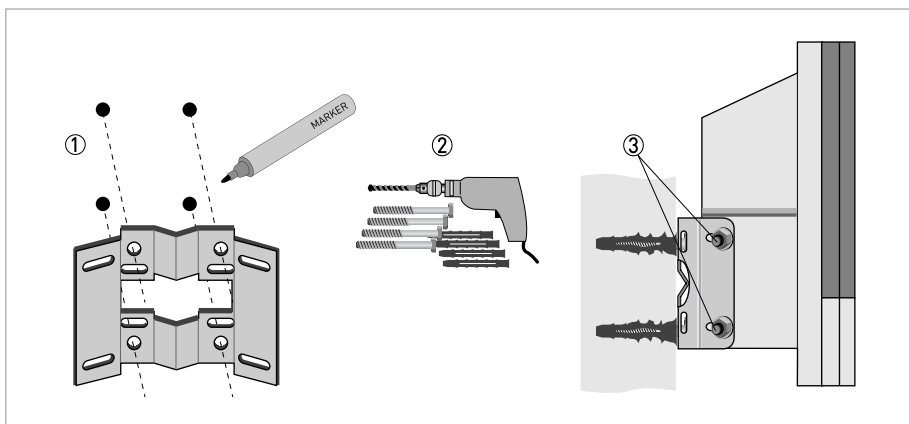

Figure 3-5: Wall mounting of the wall-mounted housing

- ① Prepare the holes with the aid of the mounting plate. For further information refer to *Mounting plate of wall-mounted housing* on page 25.
- ② Fasten the mounting plate securely to the wall.
- ③ Screw the signal converter to the mounting plate with the nuts and washers.

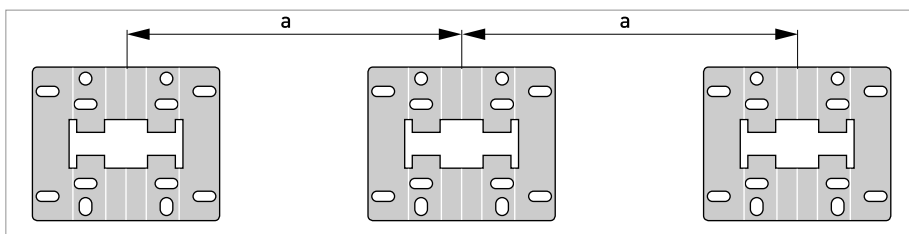

Figure 3-6: Mounting multiple devices next to each other

$a \geq 240 \text{ mm} / 9.4''$

4.1 Important notes on electrical connection

Electrical connection is carried out in conformity with the VDE 0100 directive "Regulations for electrical power installations with line voltages up to 1000 V" or equivalent national regulations.

The device must be grounded in accordance with regulations in order to protect personnel against electric shocks.

- Use suitable cable entries for the various electrical cables.
- The flow sensor and signal converter have been configured together at the factory. For this reason, please connect the devices in pairs. Ensure that the flow sensor constant GK/GKL (see nameplates) are identically set.
- If delivered separately or when installing devices that were not configured together, set the signal converter to the DN size and GK/GKL of the flow sensor.

4.2 Preparing the signal and field current cables (except TIDALFLUX)

Assembly materials and tools are not part of the delivery. Use the assembly materials and tools in compliance with the applicable occupational health and safety directives.

The electrical connection of the outer shield is different for the various housing variants. Please observe the corresponding instructions.

4.2.1 Signal cable A (type DS 300), construction

- Signal cable A is a double-shielded cable for signal transmission between the flow sensor and signal converter.
- Bending radius: $\geq 50 \text{ mm} / 2''$

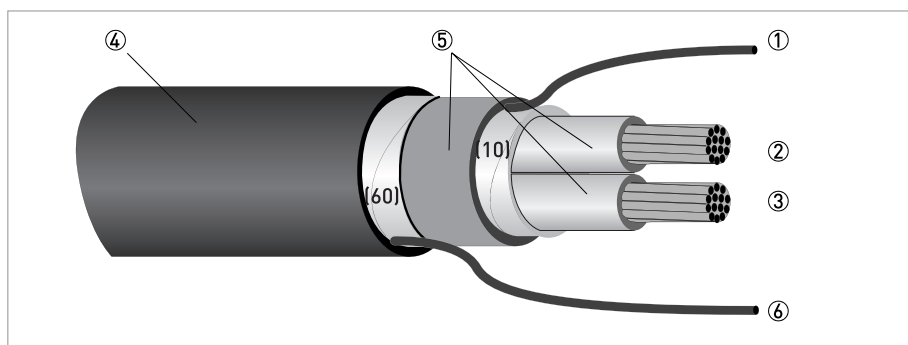

Figure 4-1: Construction of signal cable A

- ① Stranded drain wire (1) for the inner shield (10), $1.0 \text{ mm}^2 \text{ Cu} / \text{AWG } 17$ (not insulated, bare)
- ② Insulated wire (2), $0.5 \text{ mm}^2 \text{ Cu} / \text{AWG } 20$
- ③ Insulated wire (3), $0.5 \text{ mm}^2 \text{ Cu} / \text{AWG } 20$
- ④ Outer sheath
- ⑤ Insulation layers
- ⑥ Stranded drain wire (6) for the outer shield (60)

4.2.2 Length of signal cable A

For temperatures of the medium above 150°C / 300°F, a special signal cable and a ZD intermediate socket are necessary. These are available including the changed electrical connection diagrams.

Flow sensor	Nominal size		Min. electrical conductivity [µS/cm]	Curve for signal cable A
	DN [mm]	[inch]		
OPTIFLUX 1000 F	10...150	3/8...6	5	A1
OPTIFLUX 2000 F	25...150	1...6	20	A1
	200...2000	8...80	20	A2
OPTIFLUX 4000 F	2.5...150	1/10...6	1	A1
	200...2000	8...80	1	A2
OPTIFLUX 5000 F	2.5...100	1/10...4	1	A1
	150...250	6...10	1	A2
OPTIFLUX 6000 F	2.5...150	1/10...6	1	A1
WATERFLUX 3000 F	25...600	1...24	20	A1

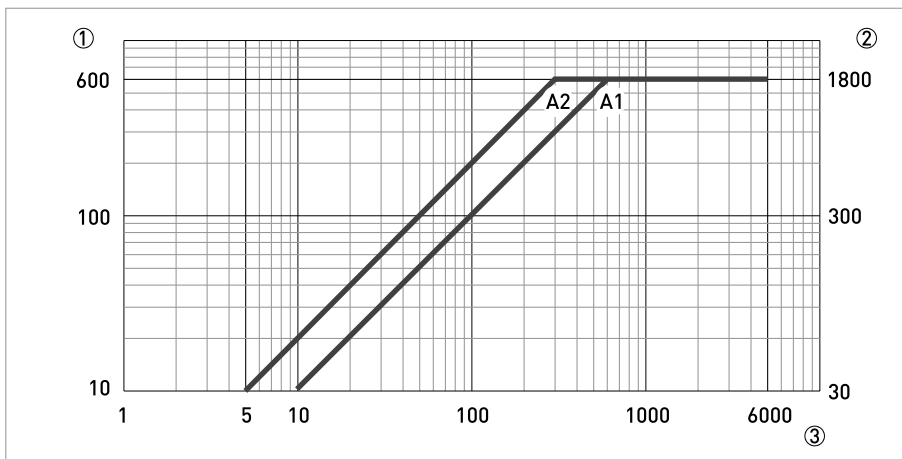

Figure 4-2: Maximum length of signal cable A

- ① Maximum length of signal cable A between the flow sensor and signal converter [m]
- ② Maximum length of signal cable A between the flow sensor and signal converter [ft]
- ③ Electrical conductivity of the medium being measured [µS/cm]

4.2.3 Signal cable B (type BTS 300), construction

- Signal cable B is a triple-shielded cable for signal transmission between the flow sensor and signal converter.
- Bending radius: $\geq 50 \text{ mm} / 2''$

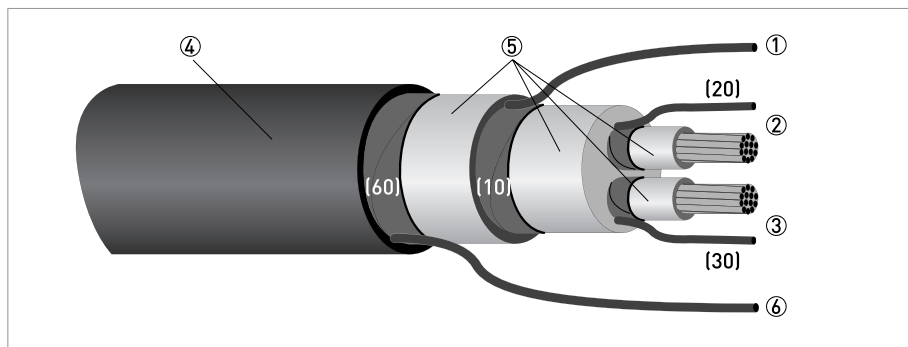

Figure 4-3: Construction of signal cable B

- ① Stranded drain wire for the inner shield (10), $1.0 \text{ mm}^2 \text{ Cu}$ / AWG 17 (not insulated, bare)
- ② Insulated wire (2), $0.5 \text{ mm}^2 \text{ Cu}$ / AWG 20 with stranded drain wire (20) of shield
- ③ Insulated wire (3), $0.5 \text{ mm}^2 \text{ Cu}$ / AWG 20 with stranded drain wire (30) of shield
- ④ Outer sheath
- ⑤ Insulation layers
- ⑥ Stranded drain wire (6) for the outer shield (60), $0.5 \text{ mm}^2 \text{ Cu}$ / AWG 20 (not insulated, bare)

4.2.4 Length of signal cable B

For temperatures of the medium above 150°C / 300°F, a special signal cable and a ZD intermediate socket are necessary. These are available including the changed electrical connection diagrams.

Flow sensor	Nominal size		Min. electrical conductivity [$\mu\text{S}/\text{cm}$]	Curve for signal cable B
	DN [mm]	[inch]		
OPTIFLUX 1000 F	10...150	3/8...6	5	B2
OPTIFLUX 2000 F	25...150	1...6	20	B3
	200...2000	8...80	20	B4
OPTIFLUX 4000 F	2.5...6	1/10...1/6	10	B1
	10...150	3/8...6	1	B3
	200...2000	8...80	1	B4
OPTIFLUX 5000 F	2.5	1/10	10	B1
	4...15	1/6...1/2	5	B2
	25...100	1...4	1	B3
	150...250	6...10	1	B4
OPTIFLUX 6000 F	2.5...15	1/10...1/2	10	B1
	25...150	1...6	1	B3
WATERFLUX 3000 F	25...600	1...24	20	B1

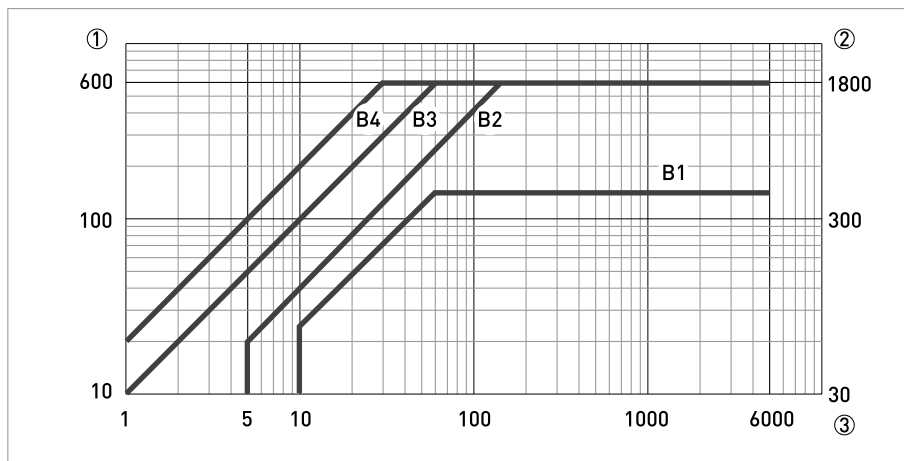

Figure 4-4: Maximum length of signal cable B

- ① Maximum length of signal cable B between the flow sensor and signal converter [m]
- ② Maximum length of signal cable B between the flow sensor and signal converter [ft]
- ③ Electrical conductivity of the medium being measured [$\mu\text{S}/\text{cm}$]

4.3 Connecting the signal and field current cables (except TIDALFLUX)

Cables may only be connected when the power is switched off.

The device must be grounded in accordance with regulations in order to protect personnel against electric shocks.

For devices used in hazardous areas, additional safety notes apply; please refer to the Ex documentation.

Observe without fail the local occupational health and safety regulations. Any work done on the electrical components of the measuring device may only be carried out by properly trained specialists.

4.3.1 Connection diagram for flow sensor, field housing

The device must be grounded in accordance with regulations in order to protect personnel against electric shocks.

- If a shielded field current cable is used, the shield must **NOT** be connected in the housing of the signal converter.
- The outer shield of signal cable A or B in the signal converter housing is connected via the strain relief terminal.
- Bending radius of signal and field current cable: $\geq 50 \text{ mm} / 2''$
- The following illustration is schematic. The positions of the electrical connection terminals may vary depending on the housing version.

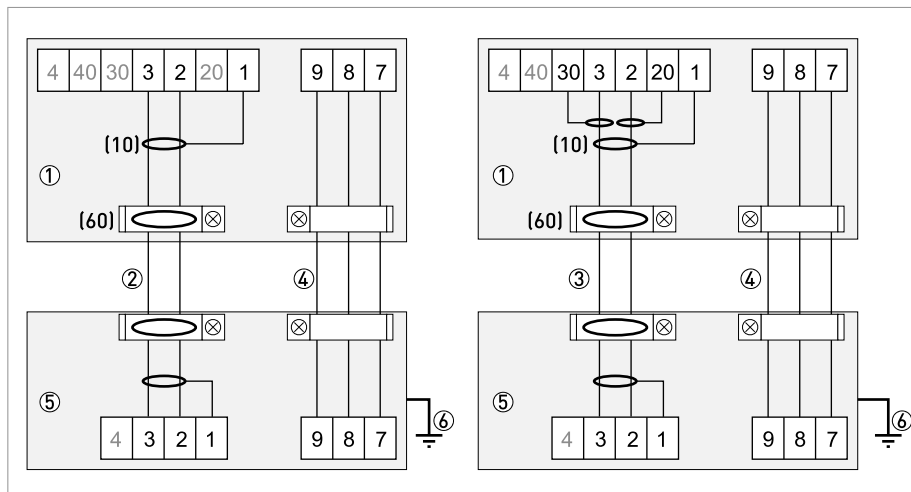

Figure 4-5: Connection diagram for flow sensor, field housing

- ① Electrical terminal compartment in housing of the signal converter for signal and field current cable
- ② Signal cable A
- ③ Signal cable B
- ④ Field current cable C
- ⑤ Connection box of flow sensor
- ⑥ Functional ground FE

4.3.2 Connection diagram for flow sensor, wall-mounted housing

The device must be grounded in accordance with regulations in order to protect personnel against electric shocks.

- If a shielded field current cable is used, the shield must **NOT** be connected in the housing of the signal converter.
- The outer shield of the signal cable is connected in the signal converter housing via the stranded drain wire.
- Bending radius of signal and field current cable: $\geq 50 \text{ mm} / 2''$
- The following illustration is schematic. The positions of the electrical connection terminals may vary depending on the housing version.

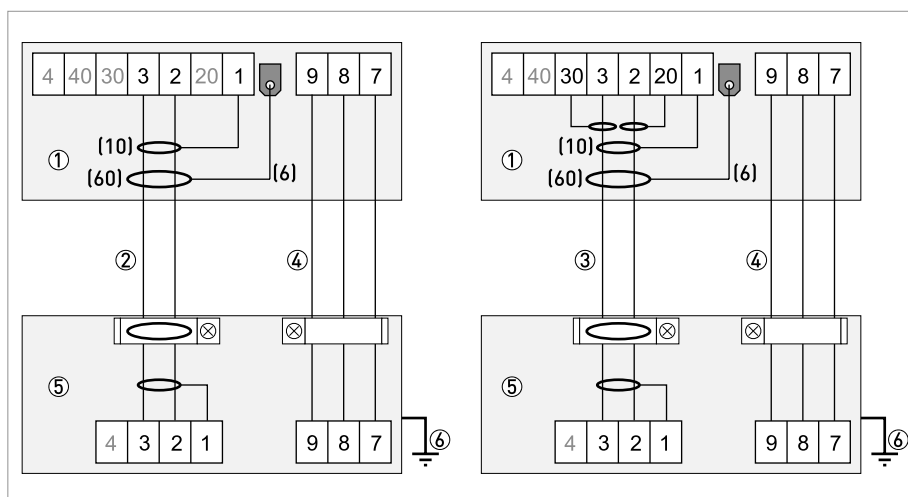

Figure 4-6: Connection diagram for flow sensor, wall-mounted housing

- ① Electrical terminal compartment in housing of the signal converter for signal and field current cable
- ② Signal cable A
- ③ Signal cable B
- ④ Field current cable C
- ⑤ Connection box of flow sensor
- ⑥ Functional ground FE

4.3.3 Connection diagram for flow sensor, 19" rack-mounted housing (28 TE)

The device must be grounded in accordance with regulations in order to protect personnel against electric shocks.

- If a shielded field current cable is used, the shield must **NOT** be connected in the housing of the signal converter.
- The outer shield of the signal cable is connected in the signal converter housing via the stranded drain wire.
- Bending radius of signal and field current cable: $\geq 50 \text{ mm} / 2''$
- The following illustration is schematic. The positions of the electrical connection terminals may vary depending on the housing version.

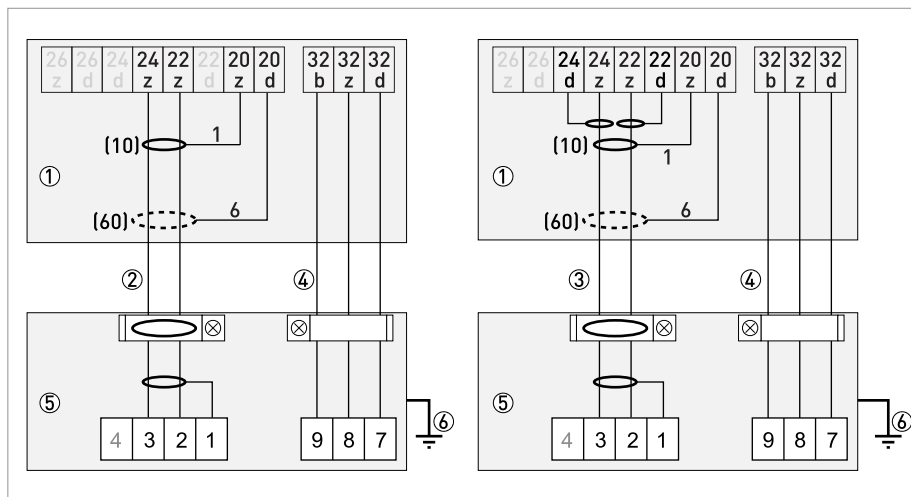

Figure 4-7: Connection diagram for flow sensor, 19" rack-mounted housing (28 TE)

- ① Electrical terminal compartment in housing of the signal converter for signal and field current cable
- ② Signal cable A
- ③ Signal cable B
- ④ Field current cable C
- ⑤ Connection box of flow sensor
- ⑥ Functional ground FE

4.3.4 Connection diagram for flow sensor, 19" rack-mounted housing (21 TE)

The device must be grounded in accordance with regulations in order to protect personnel against electric shocks.

- If a shielded field current cable is used, the shield must **NOT** be connected in the housing of the signal converter.
- The outer shield of the signal cable is connected in the signal converter housing via the stranded drain wire.
- Bending radius of signal and field current cable: $\geq 50 \text{ mm} / 2''$
- The following illustration is schematic. The positions of the electrical connection terminals may vary depending on the housing version.

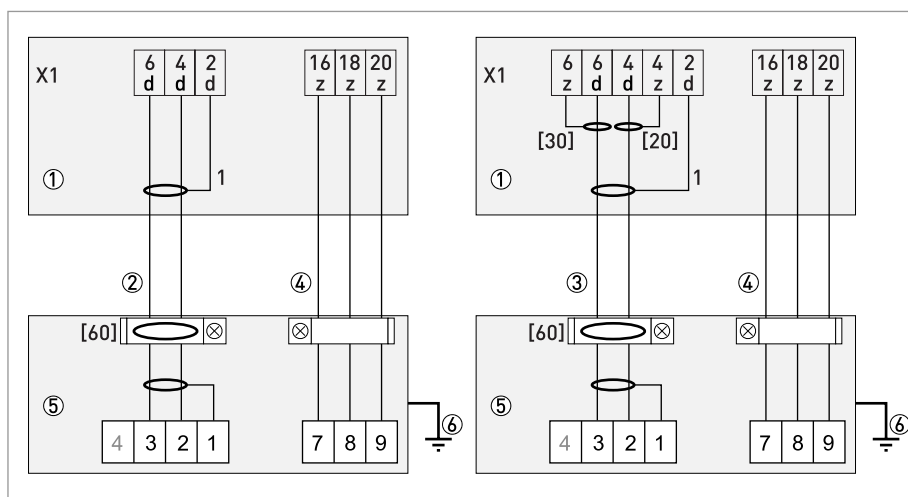

Figure 4-8: Connection diagram for flow sensor, 19" rack-mounted housing (21 TE)

- ① Electrical terminal compartment in housing of the signal converter for signal and field current cable
- ② Signal cable A
- ③ Signal cable B
- ④ Field current cable C
- ⑤ Connection box of flow sensor
- ⑥ Functional ground FE

4.4 Electrical connection only for TIDALFLUX 2000

For the connection diagrams and all relevant details for connection of the TIDALFLUX 2000 please refer to the manual of the TIDALFLUX 2000.

4.5 Connecting power - all housing variants

The device must be grounded in accordance with regulations in order to protect personnel against electric shocks.

For devices used in hazardous areas, additional safety notes apply; please refer to the Ex documentation.

- The protection category depends on the housing versions (IP65...67 or NEMA4/4X/6).
- The housings of the devices, which are designed to protect the electronic equipment from dust and moisture, should be kept well closed at all times. Creepage distances and clearances are dimensioned to VDE 0110 and IEC 60664 for pollution severity 2. Supply circuits are designed for overvoltage category III and the output circuits for overvoltage category II.
- Fuse protection ($I_N \leq 16 \text{ A}$) for the infeed power circuit, as well as a separator (switch, circuit breaker) to isolate the signal converter must be provided close to the device. The separator must be marked as the separator for this device.

100...230 VAC (tolerance range for 100 VAC: -15% / +10%)

- Note the power supply voltage and frequency (50...60 Hz) on the nameplate.
- The protective ground terminal **PE** of the power supply must be connected to the separate U-clamp terminal in the terminal compartment of the signal converter.
For 19" rack-mounted housing please refer to the connection diagrams.

240 VAC + 5% is included in the tolerance range.

12...24 VDC (tolerance range for 24 VDC: -55% / +30%)

- Note the data on the nameplate!
- When connecting to functional extra-low voltages, provide a facility for protective separation (PELV) (according to VDE 0100 / VDE 0106 and/or IEC 60364 / IEC 61140 or relevant national regulations).

12 VDC - 10% is included in the tolerance range.

24 VAC/DC (tolerance range: AC: -15% / +10%; DC: -25% / +30%)

- AC: Note the power supply voltage and frequency (50...60 Hz) on the nameplate.
- DC: When connecting to functional extra-low voltages, provide a facility for protective separation (PELV) (according to VDE 0100 / VDE 0106 and/or IEC 60364 / IEC 61140 or relevant national regulations).

*12 V is **not** included in the tolerance range.*

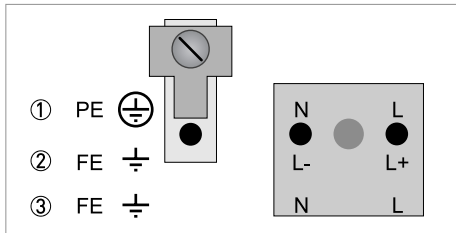

Figure 4-9: Power supply connection (excluding 19" rack-mounted housing)

- ① 100...230 VAC (-15% / +10%), 22 VA
- ② 24 VDC (-55% / +30%), 12 W
- ③ 24 VAC/DC (AC: -15% / +10%; DC: -25% / +30%), 22 VA or 12 W

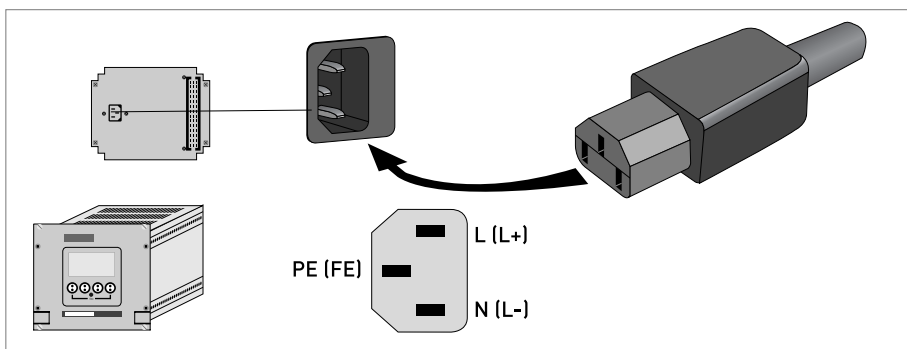

Figure 4-10: Power supply connection for 19" rack-mounted housing (28 TE)

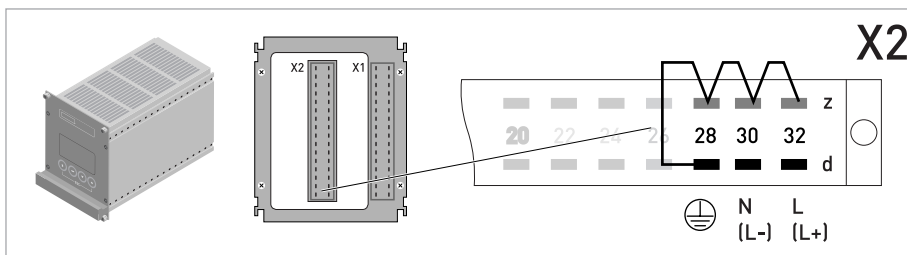

Figure 4-11: Power supply connection for 19" rack-mounted housing (21 TE)

For safety reasons the manufacturer has connected the 28d contacts internally to the 28z, 30z and 32z contacts. You are advised to also connect contacts 28z, 30z and 32z to the external protective conductor.

The protective conductor contacts must not be used to loop through the PE connection.

4.6 Inputs and outputs, overview

4.6.1 Combinations of the inputs/outputs (I/Os)

This signal converter is available with various input/output combinations.

Basic version

- Has 1 current output, 1 pulse output and 2 status outputs / limit switches.
- The pulse output can be set as status output/limit switch and one of the status outputs as a control input.

Ex i version

- Depending on the task, the device can be configured with various output modules.
- Current outputs can be active or passive.
- Optionally available also with Foundation Fieldbus and Profibus PA.

Modular version

- Depending on the task, the device can be configured with various output modules.

Bus systems

- The device allows intrinsically safe and non intrinsically safe bus interfaces in combination with additional modules.
- For connection and operation of bus systems, please note the separate documentation.

Ex option

- For hazardous areas, all of the input/output variants for the housing designs C and F with terminal compartment in the Ex d (pressure-resistant casing) or Ex e (increased safety) versions can be delivered.
- Please refer to the separate instructions for connection and operation of the Ex devices.

4.6.2 Description of the CG number

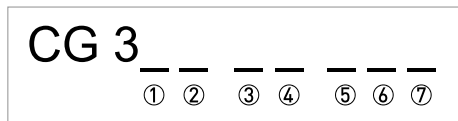

Figure 4-12: Marking (CG number) of the electronics module and input/output variants

- ① ID number: 0
- ② ID number: 0 = standard; 9 = special
- ③ Power supply option / flow sensor option
- ④ Display (language versions)
- ⑤ Input/output version (I/O)
- ⑥ 1st optional module for connection terminal A
- ⑦ 2nd optional module for connection terminal B

The last 3 digits of the CG number (⑤, ⑥ and ⑦) indicate the assignment of the terminal connections. Please refer to the following examples.

CG 300 11 100	100...230 VAC & standard display; basic I/O: I_a or I_p & S_p/C_p & S_p & P_p/S_p
CG 300 11 7FK	100...230 VAC & standard display; modular I/O: I_a & P_N/S_N and optional module P_N/S_N & C_N
CG 300 81 4EB	24 VDC & standard display; modular I/O: I_a & P_a/S_a and optional module P_p/S_p & I_p

Table 4-1: Examples for CG number

Abbreviation	Identifier for CG no.	Description
I_a	A	Active current output
I_p	B	Passive current output
P_a / S_a	C	Active pulse output, frequency output, status output or limit switch (changeable)
P_p / S_p	E	Passive pulse output, frequency output, status output or limit switch (changeable)
P_N / S_N	F	Passive pulse output, frequency output, status output or limit switch according to NAMUR (changeable)
C_a	G	Active control input
C_p	K	Passive control input
C_N	H	Active control input to NAMUR Signal converter monitors cable breaks and short circuits according to EN 60947-5-6. Errors indicated on LC display. Error messages possible via status output.
IIn_a	P	Active current input
IIn_p	R	Passive current input
-	8	No additional module installed
-	0	No further module possible

Table 4-2: Description of abbreviations and CG identifier for possible optional modules on terminals A and B

4.6.3 Fixed, non-alterable input/output versions

This signal converter is available with various input/output combinations.

- The grey boxes in the tables denote unassigned or unused connection terminals.
- In the table, only the final digits of the CG no. are depicted.
- Connection terminal A+ is only operable in the basic input/output version.

CG no.	Connection terminals								
	A+	A	A-	B	B-	C	C-	D	D-

Basic I/Os (standard)

1 0 0		$I_p + \text{HART}^{\text{®}}$ passive ①	S_p / C_p passive ②	S_p passive	P_p / S_p passive ②
	$I_a + \text{HART}^{\text{®}}$ active ①				

Ex i I/Os (option)

2 0 0				$I_a + \text{HART}^{\text{®}}$ active	P_N / S_N NAMUR ②
3 0 0				$I_p + \text{HART}^{\text{®}}$ passive	P_N / S_N NAMUR ②
2 1 0		I_a active	P_N / S_N NAMUR C_p passive ②	$I_a + \text{HART}^{\text{®}}$ active	P_N / S_N NAMUR ②
3 1 0		I_a active	P_N / S_N NAMUR C_p passive ②	$I_p + \text{HART}^{\text{®}}$ passive	P_N / S_N NAMUR ②
2 2 0		I_p passive	P_N / S_N NAMUR C_p passive ②	$I_a + \text{HART}^{\text{®}}$ active	P_N / S_N NAMUR ②
3 2 0		I_p passive	P_N / S_N NAMUR C_p passive ②	$I_p + \text{HART}^{\text{®}}$ passive	P_N / S_N NAMUR ②
2 3 0		IIn_a active	P_N / S_N NAMUR C_p passive ②	$I_a + \text{HART}^{\text{®}}$ active	P_N / S_N NAMUR ②
3 3 0		IIn_a active	P_N / S_N NAMUR C_p passive ②	$I_p + \text{HART}^{\text{®}}$ passive	P_N / S_N NAMUR ②
2 4 0		IIn_p passive	P_N / S_N NAMUR C_p passive ②	$I_a + \text{HART}^{\text{®}}$ active	P_N / S_N NAMUR ②
3 4 0		IIn_p passive	P_N / S_N NAMUR C_p passive ②	$I_p + \text{HART}^{\text{®}}$ passive	P_N / S_N NAMUR ②

CG no.	Connection terminals								
	A+	A	A-	B	B-	C	C-	D	D-

PROFIBUS PA (Ex i) (option)

D 0 0						PA+	PA-	PA+	PA-
						FISCO Device		FISCO Device	
D 1 0		I _a active		P _N / S _N NAMUR C _p passive ②		PA+	PA-	PA+	PA-
						FISCO Device		FISCO Device	
D 2 0		I _p passive		P _N / S _N NAMUR C _p passive ②		PA+	PA-	PA+	PA-
						FISCO Device		FISCO Device	
D 3 0		II _{n_a} active		P _N / S _N NAMUR C _p passive ②		PA+	PA-	PA+	PA-
						FISCO Device		FISCO Device	
D 4 0		II _{n_p} passive		P _N / S _N NAMUR C _p passive ②		PA+	PA-	PA+	PA-
						FISCO Device		FISCO Device	

FOUNDATION Fieldbus (Ex i) (option)

E 0 0						V/D+	V/D-	V/D+	V/D-
						FISCO Device		FISCO Device	
E 1 0		I _a active		P _N / S _N NAMUR C _p passive ②		V/D+	V/D-	V/D+	V/D-
						FISCO Device		FISCO Device	
E 2 0		I _p passive		P _N / S _N NAMUR C _p passive ②		V/D+	V/D-	V/D+	V/D-
						FISCO Device		FISCO Device	
E 3 0		II _{n_a} active		P _N / S _N NAMUR C _p passive ②		V/D+	V/D-	V/D+	V/D-
						FISCO Device		FISCO Device	
E 4 0		II _{n_p} passive		P _N / S _N NAMUR C _p passive ②		V/D+	V/D-	V/D+	V/D-
						FISCO Device		FISCO Device	

PROFINET IO (option)

N 0 0		RX+	RX-	TX+	TX-	TX+	TX-	RX+	RX-
		Port 2				Port 1			

① Function changed by reconnecting

② Changeable

4.6.4 Alterable input/output versions

This signal converter is available with various input/output combinations.

- The grey boxes in the tables denote unassigned or unused connection terminals.
- In the table, only the final digits of the CG no. are depicted.
- Term. = (connection) terminal

CG no.	Connection terminals									
	A+	A	A-	B	B-	C	C-	D	D-	

Modular I/Os (option)

4 __		max. 2 optional modules for term. A + B	I _a + HART® active	P _a / S _a active ①
8 __		max. 2 optional modules for term. A + B	I _p + HART® passive	P _a / S _a active ①
6 __		max. 2 optional modules for term. A + B	I _a + HART® active	P _p / S _p passive ①
B __		max. 2 optional modules for term. A + B	I _p + HART® passive	P _p / S _p passive ①
7 __		max. 2 optional modules for term. A + B	I _a + HART® active	P _N / S _N NAMUR ①
C __		max. 2 optional modules for term. A + B	I _p + HART® passive	P _N / S _N NAMUR ①

PROFIBUS PA (option)

D __		max. 2 optional modules for term. A + B	PA+ (2)	PA- (2)	PA+ (1)	PA- (1)
------	--	---	---------	---------	---------	---------

FOUNDATION Fieldbus (option)

E __		max. 2 optional modules for term. A + B	V/D+ (2)	V/D- (2)	V/D+ (1)	V/D- (1)
------	--	---	----------	----------	----------	----------

PROFIBUS DP (option)

F _0		1 optional module for term. A	Termination P	RxD/TxD-P(2)	RxD/TxD-N(2)	Termination N	RxD/TxD-P(1)	RxD/TxD-N(1)
------	--	-------------------------------	---------------	--------------	--------------	---------------	--------------	--------------

Modbus (option)

G __ ②		max. 2 optional modules for term. A + B		Common	Sign. B (D1)	Sign. A (D0)
H __ ③		max. 2 optional modules for term. A + B		Common	Sign. B (D1)	Sign. A (D0)

① Changeable

② Not activated bus terminator

③ Activated bus terminator





KROHNE – Process instrumentation and measurement solutions

- Flow
- Level
- Temperature
- Pressure
- Process Analysis
- Services

Head Office KROHNE Messtechnik GmbH
Ludwig-Krohne-Str. 5
47058 Duisburg (Germany)
Tel.: +49 203 301 0
Fax: +49 203 301 10389
info@krohne.com

The current list of all KROHNE contacts and addresses can be found at:
www.krohne.com

KROHNE