



KOBOLD Instruments Inc.
 1801 Parkway View Drive
 Pittsburgh, PA 15205
 PH: 412-788-2830
 FAX: 412-788-4890
 www.koboldusa.com

**Series KPH300
 Adjustable Pressure Switch**

Precautions

- **User's Responsibility for Safety:** KOBOLD manufactures a wide range of process sensors and technologies. While each of these technologies are designed to operate in a wide variety of applications, it is the user's responsibility to select a technology that is appropriate for the application, to install it properly, to perform tests of the installed system, and to maintain all components. The failure to do so could result in property damage or serious injury.
- **Wiring and Electrical:** Because this is an electrically operated device, only properly trained personnel should install and maintain this product. Be sure that the power supplied to the unit is appropriate for the device. Electrical wiring of the sensor should be performed in accordance with all applicable national, state and local codes.

- **Make a Fail-Safe System:** Design a fail-safe system that accommodates the possibility of sensor, relay or power failure. In critical applications, KOBOLD recommends the use of redundant backup systems and alarms in addition to the primary system.

Switch Adjustment:

Switchpoint:

The switchpoint is adjusted by using a 2 mm hex wrench inserted into the hex-headed screw within the threaded electrical connector mounting boss. Clockwise rotation of the adjusting screw will increase the switchpoint; counter-clockwise rotation will decrease the switchpoint.

CAUTION: Do not attempt to force the adjustment screw beyond its maximum or minimum adjustment point or damage to the switch will occur. Typical adjustment range is ~10-12 turns.

Wiring Diagram:

SPDT Switch Wiring:

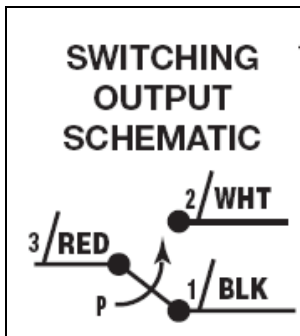

Dimensions:

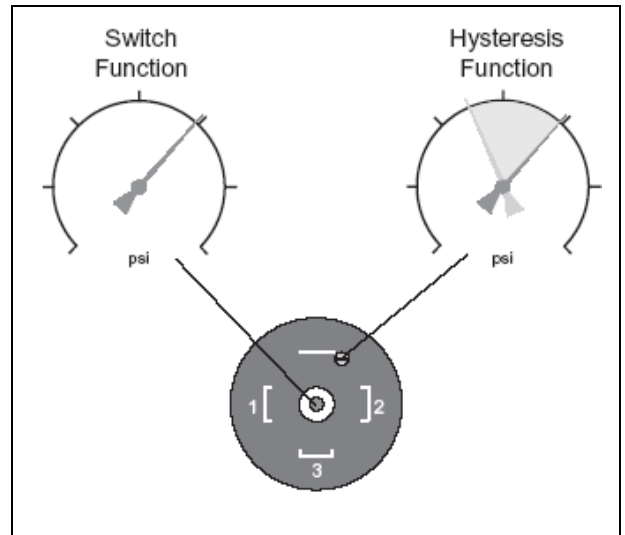
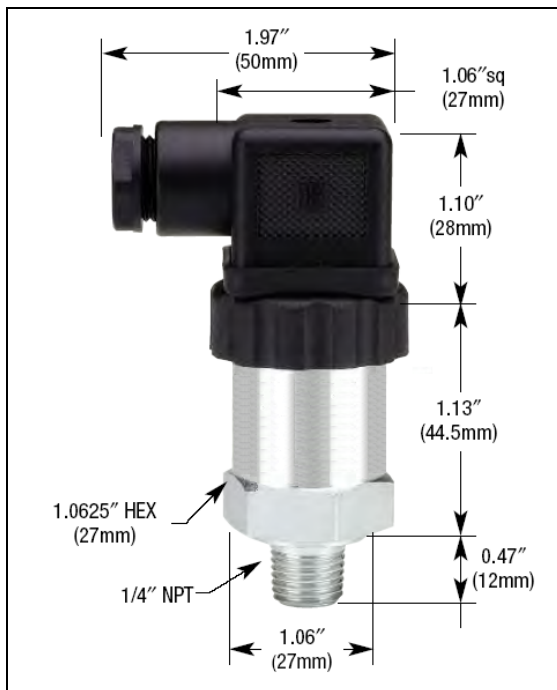

Hysteresis:

Switch hysteresis is adjusted by using a small, slotted (blade) screwdriver inserted into the access hole located near the equipment ground terminal. Clockwise rotation of the adjusting screw will increase the amount of hysteresis; counter-clockwise rotation will decrease the amount of hysteresis. NOTE: Rotating the Hysteresis adjustment completely clockwise or counter-clockwise will disable the switch function.