

Operating Instruction
for
Electronic Flow Meter / Monitor
Compact Version

Model: KAL-A
KAL-AK



1. Contents

1....Contents.....	2
2....Note	3
3....Instrument Inspection.....	3
4....Regulation Use.....	3
5....Operating Principle.....	4
6....Mechanical Connection.....	5
7....Electrical Connection	5
8....Output	8
9....Commissioning.....	9
10..Maintenance	12
11..Diagnostics	12
12..Technical Information.....	12
13..Order Codes	13
14..Dimensions	14
15..EU Declaration of Conformance.....	15

Manufactured and sold by:

Kobold Messring GmbH
Nordring 22-24
D-65719 Hofheim
Tel.: +49(0)6192-2990
Fax: +49(0)6192-23398
E-Mail: info.de@kobold.com
Internet: www.kobold.com

2. Note

Please read these operating instructions before unpacking and putting the unit into operation. Follow the instructions precisely as described herein.

The devices are only to be used, maintained and serviced by persons familiar with these operating instructions and in accordance with local regulations applying to Health & Safety and prevention of accidents.

When used in machines, the measuring unit should be used only when the machines fulfil the EC-machine guidelines.

3. Instrument Inspection

Instruments are inspected before shipping and sent out in perfect condition.

Should damage to a device be visible, we recommend a thorough inspection of the delivery packaging. In case of damage, please inform your parcel service / forwarding agent immediately, since they are responsible for damages during transit.

4. Regulation Use

The KOBOLD **KAL-A..** Flow Meter is intended for use in measuring moderate flow rates of low-viscous or dirty liquids.

The KOBOLD **KAL-AK..** Flow Meter is intended for use in measuring and monitoring moderate flow rates of low-viscous or dirty liquids.

Analogue Output / Limiting Signal

For measuring the flow rate of the liquids the device is equipped with a 4-20 mA output signal. Additionally the model KAL-AK.. is equipped with a limit switch (NPN or PNP).

Trend Display

A LED bar graph display indicates the current flow rate and the set point (KAL-AK) via a flashing LED.

Sensor

The model KAL-A and KAL-AK consists of a sensor with integrated electronic. The devices may only be used for liquids to which the probe material is resistant. With proper installation and maintenance, the probes are not sensitive to soiling and cause practically no pressure loss.

KAL-A(K)

Materials

Sensor Stainless steel (1.4301, 1.4305, 1.4571)
Electronic cover Glass fibre reinforced polyamide

Setting ranges

in relation to nominal tube diameter

ID (mm)	Meas. range (L/min) water	ID (mm)	Meas. range (L/min) water
8	0.12 - 6.0	40	3.0 - 150
10	0.19 - 9.4	50	4.7 - 235
15	0.42 - 21.8	60	6.8 - 340
20	0.75 - 37.7	80	12.0 - 603
25	1.18 - 59.0	100	18.8 - 942
30	1.7 - 84.8	150	42.4 - 2120



Attention! The flow ranges specified in the table above have been calculated for each pipe diameter based on the known velocity range of the KAL-A(K). It must be noted that flow in pipes is non-uniform across the pipe cross section, and approaches zero at the pipe wall. This means that, in practice, the depth of installation of the probe, the internal pipe diameter, and the flow profile of the liquid in the pipe can interact to produce significant deviations from the flow ranges in the above table.

5. Operating Principle

The KAL-A... Flow Meter/ -Monitor uses the proven thermal dispersion principle and operates as follows: The probe is heated internally to a few degrees above the temperature of the medium into which it extends. The flowing medium takes this heat off the probe, i.e. the probe is cooled down. The cooling rate is proportional to the flow rate. The electronic converts the signal into a proportional current signal (4-20 mA) linear to the flow rate. With model KAL-AK the requested flow rate will be compared with the flow rate existing and if the set- point is reached a PNP/NPN switch is activated. The microprocessor-controlled design permits simple calibration and set-up. The compact probe design permits monitoring of flow rate with minimum pressure loss.

6. Mechanical Connection

Prior to installation

- Ensure that the actual system flow rate is within the measuring range of the KAL-A(K).
- Ensure that the maximum system temperature and pressure are within the limits specified per section (see section 12. Technical Information)

Fitting

Mount the sensor into the piping and make sure that it is completely filled with fluid. The probe tip has to reach at least 5 mm (better > 5 mm) into the pipe (see below).

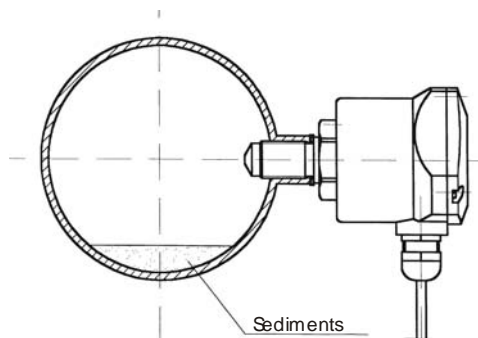

Fitting position

The sensor can be mounted in any orientation as long as the piping is completely filled with fluid. The mounting position has to be smooth and free of turbulence.

(Recommended input and output length: 5 x pipe diameter, of straight - run piping both upstream and downstream of the flow switch). In case of sediments in the pipe the shown mounting position is recommended.

7. Electrical Connection

- Screw in sensor.
- Remove electronic cover.
(The fixing screws are secured against falling out)
- Strip 4-wire cable (approx. 40-60 mm) and pull through cable gland.
Tighten cable gland.
Connect wires to terminal connector block according to their functions.
- Ensure that the power is disconnected during the connection of the cable.



Attention! SET-pushbutton must not be pressed while switching supply voltage on.

- After connection, apply supply voltage of 24 VDC \pm 20% (see Technical Information)

KAL-A(K)



Attention! Ensure that the voltage of your installation corresponds to the voltage values given on the device's specification plate.

- Flood piping in which the sensor has been mounted with medium.
- Check the sensor thread for tightness.
- Check function of electronic (set-point LED must flash)
- Calibrate flow switch (see 9. Commissioning)

Function elements

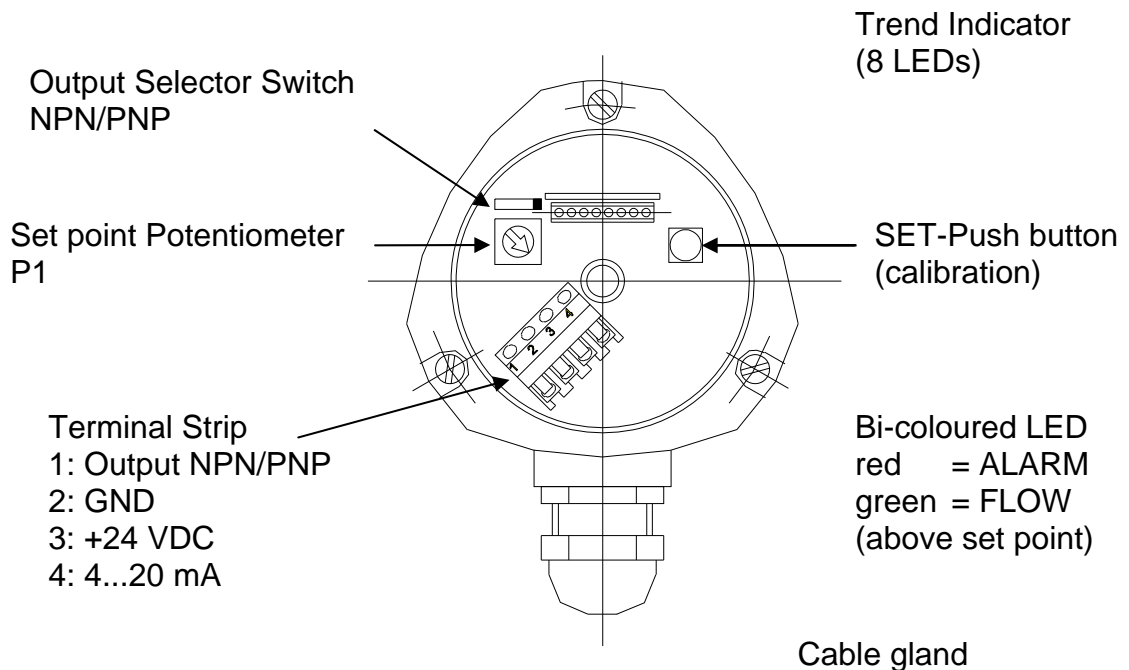

LED Trend Indicator

- The LED Trend Indicator (8 LEDs) is used to indicate the flow rate (LED, starting left). For model KAL-AK the adjusted switching point is additionally indicated by a flashing LED.
- If the flow rate has reached the set point value selected by the user, then the LED is flashing.

Bi-coloured LED (KAL-A)

- If bi-coloured LED is green: Instrument is in operation mode.
- If bi-coloured LED is flashing green: Instrument is in calibration mode.
- If bi-coloured LED is flashing red: Instrument signal an error (check the temperature of the liquid).

Bi-coloured LED (KAL-AK)

- The bi-coloured LED serves to additionally display a switching point (KAL-AK).
RED = ALARM (flow below the set point)
GREEN = (flow above the set point)
- If bi-coloured LED is flashing green: Instrument is in calibration mode.
- If bi coloured LED is flashing red: Instrument signal an error (check the temperature of the liquid).

Terminal strip

The terminal strip serves the electrical connection.

The device only operated with 24 VDC (DC \pm 20%)

Terminal 1: Output NPN/PNP (only KAL-AK)

Terminal 2: GND

Terminal 3: + 24 VDC

Terminal 4: Analogue output

Plug connector M12

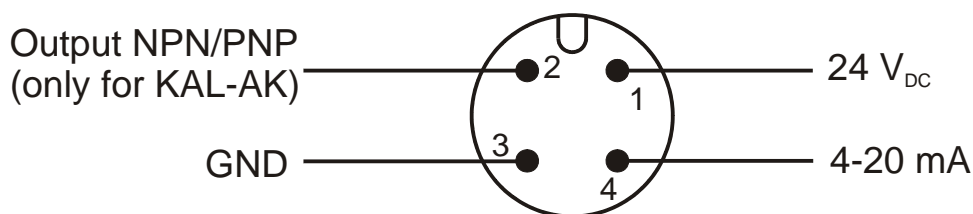

SET pushbutton

The calibration switch is used to start the flow calibration procedure

Potentiometer

a.) **Calibration:** left-hand stop = zero flow calibration
right-hand stop = maximum flow calibration

b.) Switching point adjustment (KAL-AK)

The set point potentiometer is used to adjust the flow set point. You will notice that the flashing LED moves along the trend indicator scale as the set point potentiometer is adjusted.

Output Selector Switch

The output selector switch is used to select between the output logic NPN and PNP. This adjustment is factory-made and needs not to be changed anymore under normal conditions.

Output selector switch right: NPN-output

Output selector switch left: PNP-output

8. Output

Analogue output

The analogue output supplies a current signal proportional to the flow rate (0-100% = 4-20 mA). Terminal 2 is the bench mark of the analogue output GROUND (0 VDC).

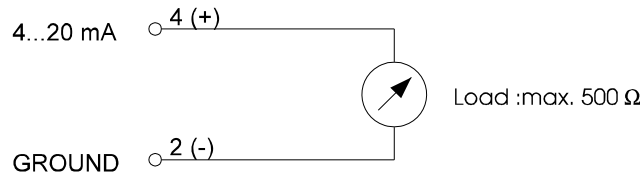

Switching point (KAL-AK)

The output characteristics of the switch logic will be customised by the factory.

NPN-output

The semiconductor output switches to GND (GROUND = 0 VDC) or is highly resistant. The maximum output current is 400 mA.

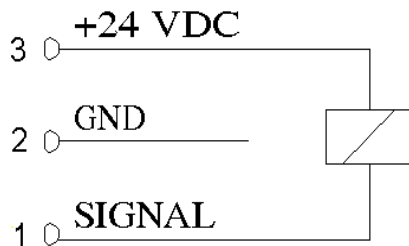

The reference point for the NPN-output is +24 VDC.

PNP-output

The semiconductor output switches to +24 VDC or is highly resistant. The maximum output current is 400 mA.

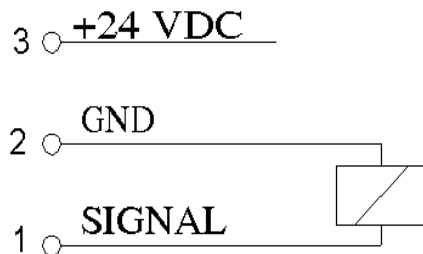

The reference point for the PNP-output is GND (GROUND = 0 VDC).

N/O function (KAL-AK)

In the N/O function the output is switching into the low resistance state (PNP → +24 VDC impress on the output; NPN → GND 0 VDC impresses on the output), if the actual value has reached or exceeded the set point

At the same time the green LED is flashing.

If the actual value is falling below the set point, then the output will become highly resistant and the red LED will flash (= ALARM-condition).

In case of a break-down of the power supply the output will be switched to highly resistant (ALARM-condition).

9. Commissioning

The use of this meter in machines according to directive 89/392/EWG is prohibited until the complete machine complies to this directive.

After mechanical ("Mechanical Connection") and electrical ("Electrical Connection") installation of the sensor the flow meter has to be put into operation as described in this section.

Calibration

a) Zero flow calibration

- Stop the flow of the liquid in the piping in which the sensor is installed. It is important that the sensor tip be immersed in the liquid. There should be no bubbles around the sensor tip.
- Turn set point adjustment potentiometer counter clockwise to its far left-hand stop and now briefly press the SET button.
The bi-coloured LED will flash green.
- Do not make any changes (potentiometer setting, etc.) while the bi-coloured LED is blinking. This adjustment phase will last approx. 5-15 sec.
- When the bi-coloured LED stops flashing, the zero flow calibration is set.
The device now switches automatically to the monitoring mode and displays no flow. The LED strip is not illuminated; only the threshold value LED is flashing.

b) Calibration of the maximum flow

The flow monitor is factory pre-set at its maximum span. This span corresponds to a water flow velocity of 2 m/s. If fluid is running through the pipe the trend indicator is showing the actual system flow. At lower flow speeds, not all 8 LEDs will illuminate. To achieve finer monitoring resolution, the measuring range can (should) be adapted to better fit the actual flow speed.

- Rotate the potentiometer clockwise as far as it will go (to the right-hand stop). The extreme right-hand LED in the LED strip will blink. The maximum flow speed must be present.
- Now press the SET button. The bi-coloured LED blinks green.
- Do not make any changes (potentiometer setting, etc.) while the bi-coloured LED is blinking. This adjustment phase will last approx. 5-15 sec.
- The setting procedure is now complete. The device now switches automatically to the monitoring mode. This adjustment has set the device measuring range so that it now extends across the entire analogue output range (0-100% = 4-20 mA) and the LED trend indicator (8-LEDs).
- The adjustment procedure is now complete. It may be repeated as often as necessary.

c) Measuring mode

After adjustment, the flow monitor is once again in measuring mode.

The flow is constantly monitored and the actual value of the flow speed is displayed on the LED strip.

Switching point adjustment (KAL-AK)

The potentiometer is now used to set the switching point (threshold) of the flow switch. The switching point is displayed as a blinking LED. If the flow rate increases to the point that illuminated LEDs (actual flow value) reaches the position of the blinking LED (set point), the flow monitor switches over from ALARM to FLOW. This can be seen at the display: the bi-coloured LED that was showing a steady red light now switches to a steady green light. The output is also switched at the same time.

slowly flashing switching point-LED (set point)

○ ○ ○ ○ ⊗ ○ ○ ○ ○

⊗ Bi-coloured LED = red

Actual value < set point

Alarm status

Actual value = 0: no flow present

slowly flashing switching point-LED (set point)

⊗ ⊗ ○ ⊗ ○ ○ ○ ○

LED ⊗ Bi-coloured LED = red

Actual value

Actual value < set point

Alarm status

Actual value too low

fast flashing switching point-LED (set point)

⊗ ⊗ ⊗ ⊗ ○ ○ ○ ○

LED ⊗ Bi-coloured LED = green

Actual value

Actual value = set point

Flow status currently being switched

Actual value has just reached set point

slowly flashing switching point-LED

⊗ ⊗ ⊗ ⊗ ⊗ ⊗ ○ ○

LED actual value

⊗ Bi-coloured LED = green

Actual value > set point

Flow status (ideal conditions)

This is the most desirable status.

After the settings are completed, screw the cover tightly back on the housing

10. Maintenance

The unit is maintenance free. The sensor should be inspected in monthly intervals for deposits (calcination etc.) and if necessary be cleaned.

11. Diagnostics

The KAL-A(K) continuously self monitors the sensing probe and the micro-processor system upon short-circuit and circuit breaking. Any fault in these parts of the electronics will be signalled by a flashing red bi-coloured LED and a simultaneous flashing LED-bar (⇒ KOBOLD Service).

12. Technical Information

Power Supply:	24 V _{DC} ± 20 %,
Power Consumption:	max. 3,6 W (typically 1.2 W) at rated voltage
Output Characteristics:	4-20 mA (optional 0-20 mA) Max. load 500 Ohm
Switching Point Adjustment:	via Potentiometer (KAL-AK) Semi-conductor output NPN or PNP (factory-set on customer request)
Switching Characteristics:	N/O
Switching Output:	max. 400 mA
Switch Status Indication:	Bi-coloured LED (DUO-LED) red = ALARM, green = FLOW
Standby Time:	max. 12 sec
Ambient Temperature:	-20 to +60 °C (-4 to 140 °F)
Housing Protection:	IP 65
Calibration Data:	stored in non-volatile memory, data retained for at least 10 years in the event of a power failure
Measuring range:	4 cm/s... 2 m/s
Accuracy:	± 10 % f.s.
Repeatability:	± 1 % f.s.
Medium Temperature:	-20 to +80 °C (-4 to 176 °F)
Temperature gradient:	unlimited
Maximum Pressure:	100 bar
Connection:	G 1/2 (G 1/4, G 3/4, M 12x1, 1/4" NPT, 1/2" NPT, 3/4" NPT)
Wetted Parts:	1.4305 (1.4301, 1.4571 on request)
Response Time:	5 sec.

13. Order Codes

Order example: **KAL-A1308A4PG**

Version	Connection	Material stainless steel / version			Electr. connection
		1.4301	1.4305	1.4571	
4-20 mA/ without contact	G ¹ / ₄	KAL-A1308A4	-	KAL-A1408A4*	PG =cable gland M16x1,5 ST = connector M12x1
	G ¹ / ₂	KAL-A1315A4	KAL-A1215A4	KAL-A1415A4	
	G ³ / ₄	KAL-A1320A4	-	KAL-A1420A4*	
	M 12 x 1	KAL-A0312A4	-	-	
	¹ / ₄ NPT	KAL-A5308A4	-	KAL-A5408A4*	
	¹ / ₂ NPT	KAL-A5315A4	-	KAL-A5415A4	
	³ / ₄ NPT	KAL-A5320A4	-	KAL-A5420A4*	
Tri-Clamp, DIN 32676	-	-	KAL-A4440A4**		
4-20 mA/ N/O contact NPN/PNP switchable	G ¹ / ₄	KAL-AK1308AS	-	KAL-AK1408AS*	PG=cable gland M16x1,5 ST=Connector M12x1
	G ¹ / ₂	KAL-AK1315AS	KAL-AK1215AS	KAL-AK1415AS	
	G ³ / ₄	KAL-AK1320AS	-	KAL-AK1420AS*	
	M 12 x 1	KAL-AK0312AS	-	-	
	¹ / ₄ NPT	KAL-AK5308AS	-	KAL-AK5408AS*	
	¹ / ₂ NPT	KAL-AK5315AS	-	KAL-AK5415AS	
	³ / ₄ NPT	KAL-AK5320AS	-	KAL-AK5420AS*	
Tri-Clamp, DIN 32676	-	-	KAL-AK4440AS**		

*stainless steel hexagon 1.4301

**stainless steel 1.4404

KAL-A(K)

14. Dimensions

KAL-K..., KAL-A(K)

A (mm)	C (mm)	D (mm)
G ¼	26	123
G ½	40	137
G ¾	43	140
M12x1	23	120
¼ NPT	16	123
½ NPT	27	137
¾ NPT	33	133

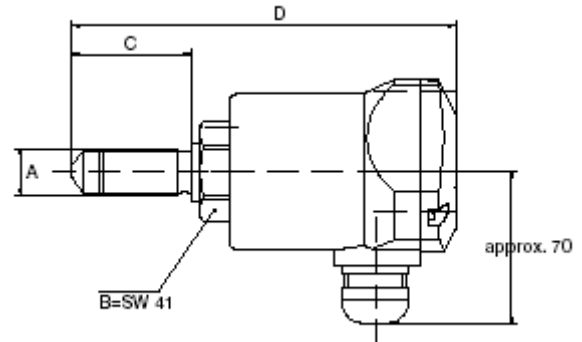

KAL-... Sensor

A (mm)	B	C (mm)	D (mm)
M12x1	SW 19	23	43
G ¼	SW 19	26	43
G ½	SW 27	43	58
G ¾	SW 32	43	58

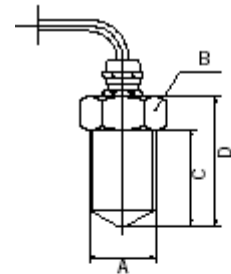

KAL-... with pipe fitting

A	B	C (mm)	D (mm)	E (mm)
G ¼	SW 27	10	50	81
G ½	SW 27	10	50	81
G ¾	SW 32	15	52	82,5
G 1	SW 39	15	56	85
G 1¼	SW 46	15	50	90
G 1½	SW 55	15	50	92,5

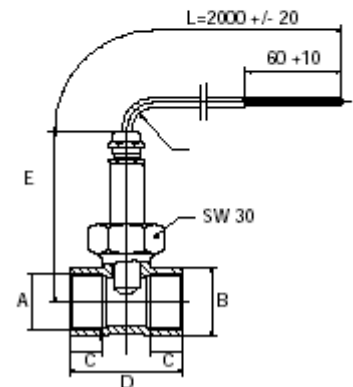

KAL-..4440 with Tri clamp

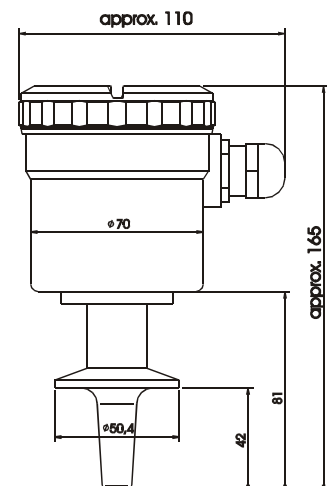

15. EU Declaration of Conformance

We, KOBOLD-Messring GmbH, Hofheim-Ts, Germany, declare under our sole responsibility that the product:

KAL-A Electronic Flow Meter

KAL-AK Electronic Flow Meter / Monitor

to which this declaration relates is in conformity with the standards noted below:

EN 61000-6-3:2011-09

Electromagnetic compatibility (EMC) - Part 6-3: Generic standards - Emission standard for residential, commercial and light-industrial environments

EN 61000-6-1:2007-10

Electromagnetic compatibility (EMC) - Part 6-1: Generic standards - Immunity for residential, commercial and light-industrial environments

Also the following EC guidelines are fulfilled:

2014/30/EU

EMC Directive

2011/65/EU

RoHS (category 9)



H. Peters
General Manager



M. Wenzel
Proxy Holder

Hofheim, 12. May 2016