

# KR2S SERIES GRAPHIC RECORDER



KR2S Series are advance touch screen display (Keyless) paperless Graphic Recorder with high performance and high operating function along with high visibility 5.7" VGA TFT Color LCD display. Universal input with high speed of sampling rate 100msec and high accuracy rating of  $\pm 0.1\%$  realized. Measured data is stored into memory and support up to 8GB through USB and CF Card. As it can be monitored by a web browser display on several computers on intranet or internet, FTP transfer of data file and E-mail notification are also available.



## FEATURES

- **Employing clear 5.7"VGA TFT color LCD display**
  - Large-sized high visibility display with various display functions. Real time/Historical trend screen, Circular trend screen, Bar-graph screen, Data screen are selectable for various applications.
- **Large capacity of data memory and various recording method**
  - USB slot and CF card is equipped as standard memory provided 2GB and optionally expandable up to 8 GB. Various data storing methods are selectable such as schedule programming by time of day and time of date, recording start-up by external signal, and event and data logging of before and after trigger points for alarm.
- **Multi points recording with high speed/accuracy**
  - High-speed recording of approximately 100msec for 4 points and 1 sec for 6/12 points and high accuracy of  $\pm 0.1\%$  were realized. Stable measuring and recording are possible with high speed.
- **Easy operating and programming without manual**
- **USB port provided in front**
  - Readout of data and files are possible by connecting through an USB memory stick for PC.
- **LAN network capability**
  - Various networked environment such as remote monitoring by browser, FTP, HTTP, SNMP and DHCP server and E-mail notification are applied as Ethernet is equipped as standard.
- **Safety system and reliability**
  - No battery backup needed for recorded storage data.
- **Analyzing/data acquisition application software**
  - It is easy to replay and edit the recorded data file. Replay display has functions of vertical/horizontal trend, circular trend and also wave-analyzing and marking by using the cursor.
- **Graphic screen**
  - Custom graphic which the user can see their operation easily is available.

## MODELS

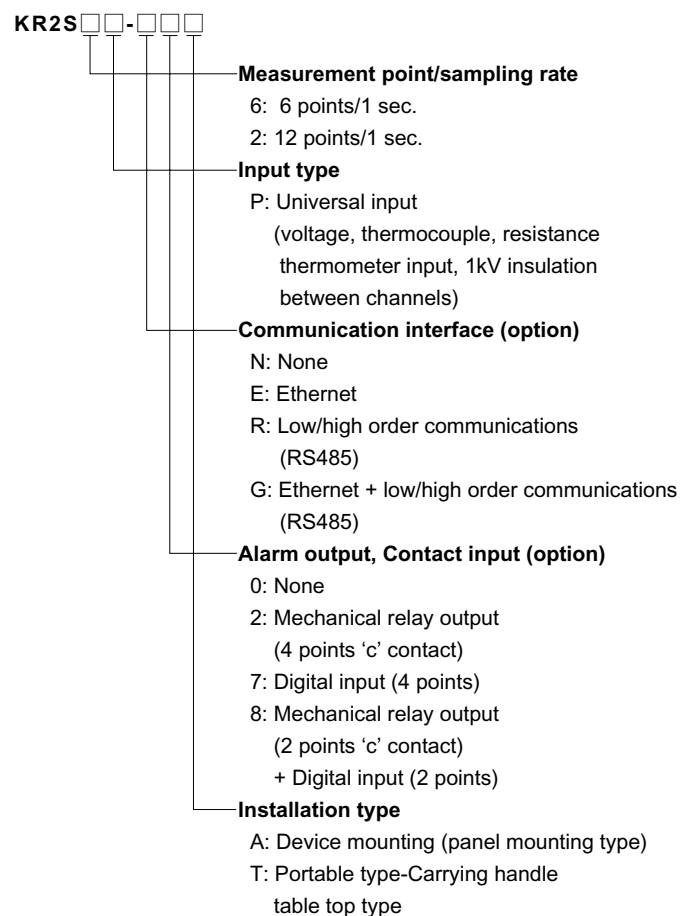

\* If the recording cycle is set less than 500ms (100 to 500 ms), input channel point becomes 100ms for 4 points automatically.

# KR2S SERIES

## SCREENS

Sharp touch panel display based on Human Engineering such as color, line, thickness, key position. Adopts VGA (640X480) which has 4 times the resolution of conventional model.

### Data screen

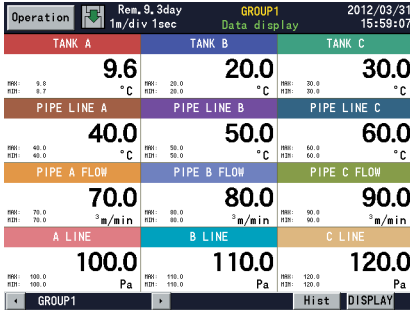

### Bar-graph screen

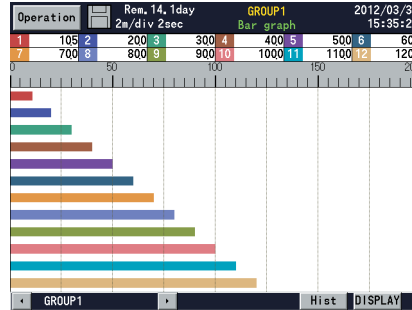

### Real-time trend screen

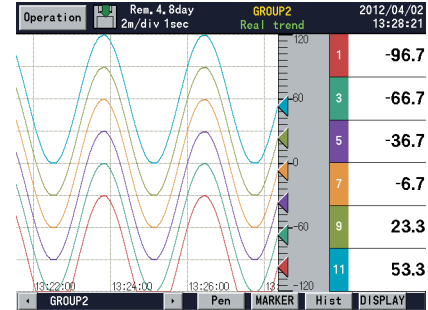

### Graphic screen

Enable to create custom display for each user\*.

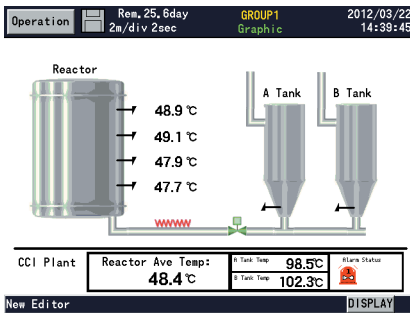

### Pen writing

Free writing by 16 colors.

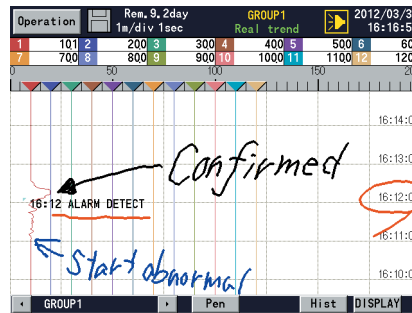

### Circular trend screen

High-resolution color and easy to read curve.

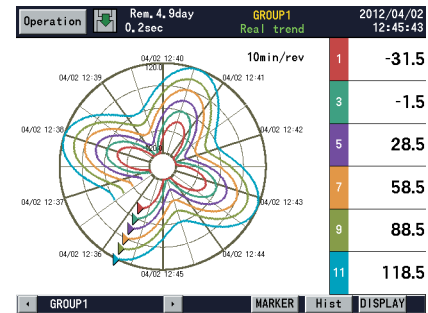

### 2-Zone screen

Split the trend in 2-zones and monitor.

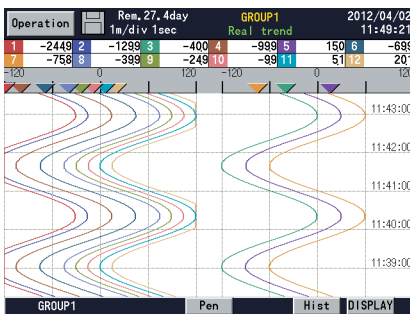

### Dual trend screen

2 split display for real time trend and historical trend. Scroll available for historical trend.

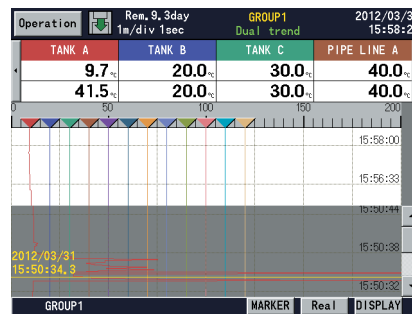

### Historical trend screen

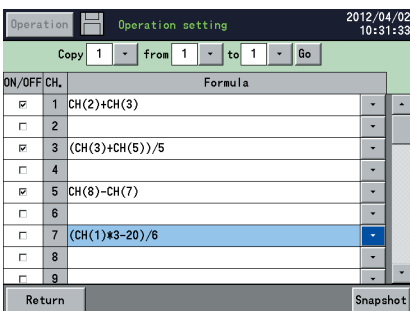
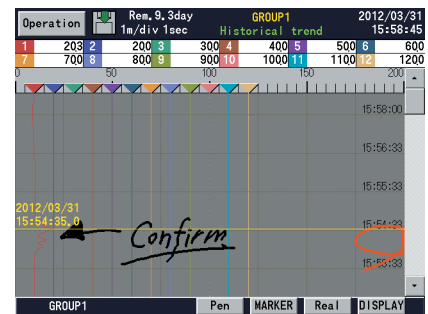

### Math functions

Easy to set and manage the formula.

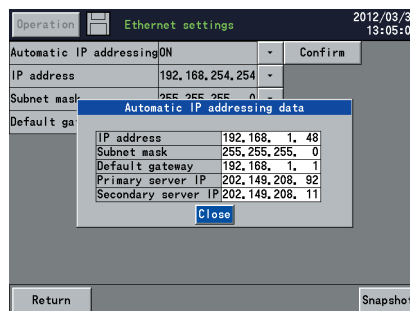

### Various communication function

Enable to use E-mail, FTP, HTTP, SNMP, and DHCP. (Automatic acquisition IP address)

\*Graphic screen feature is provided optionally. BMP image has to be prepared by customer.

## INPUT SPECIFICATIONS

Measuring points: 6 points, 12 points  
 Input types: Universal  
 DC voltage ---  $\pm 13.8\text{mV}$ ,  $\pm 27.6\text{mV}$ ,  $\pm 69.0\text{mV}$   
 $\pm 200\text{mV}$ ,  $\pm 500\text{mV}$ ,  $\pm 2\text{V}$   
 $\pm 5\text{V}^*$ ,  $\pm 10\text{V}^*$ ,  $\pm 20\text{V}^*$ ,  $\pm 50\text{V}^*$   
 (\*with built-in voltage divider)  
 DC current --- With external shunt resistor (sold separately)  
 Thermocouple --- B, R, S, K, E, J, T, N, PtRh40-PtRh20,  
 W-WRe26, WRe5-WRe26, PlatinelII, NiMo-  
 Ni, CR-AuFe, U, L  
 Resistance thermometer --- Pt100, JPt100, Pt-Co, Pt50  
 \*Contact CHINO for Nickel-100, Pt130, Pt25, Pt46, Cu10, Cu25,  
 Cu53  
 Accuracy ratings: Refer to the table of measuring range and accuracy  
 ratings  
 Reference junction compensation accuracy:  
 K, E, J, T, N, PlatinelIII ---  $\pm 0.5^\circ\text{C}$  or less  
 R, S, W-WRe26, WRe5-WRe26, NiMo-Ni,  
 CR-AuFe, U, L ---  $\pm 1.0^\circ\text{C}$  or less  
 Sampling rate: Approximately 1s / 12 points  
 Burnout: Disconnection of input signal is detected on  
 thermocouple and resistance thermometer input.  
 UP/DOWN/DISABLE is selectable.  
 Scaling: Range/scale is selectable.  
 Digital filter: Programming FIR filter for each point (common to  
 all points)  
 Allowable signal source resistance:  
 Thermocouple input (burnout disable/  
 DC voltage input ( $\pm 2\text{V}$  or less) ---  $1\text{k}\Omega$  or less  
 DC voltage input ( $\pm 5\text{V}$  or more) ---  $100\Omega$  or less  
 Resistance thermometer --- Per wire  $10\Omega$  or less  
 (same resistance for 3 wires)  
 Input resistance: Thermocouple --- Approx.  $1\text{M}\Omega$   
 DC voltage input ---  $\pm 2\text{V}$  or less : Approx.  $1\text{M}\Omega$   
 $\pm 5\text{V}$  to  $\pm 50\text{V}$  : Approx.  $1\text{M}\Omega$   
 Maximum input voltage:  
 DC voltage input ( $\pm 2\text{V}$  or less/  
 Thermocouple input (burnout enable) ---  $\pm 10\text{VDC}$   
 Resistance thermometer input ---  $\pm 6\text{VDC}$   
 DC voltage input ( $\pm 5\text{V}$  to  $\pm 50\text{V}$ ) ---  $\pm 60\text{VDC}$   
 Dielectric strength between channels:  
 $1000\text{V AC}$  or more between each channel  
 (High strength semiconductor relay used)  
 (B terminal of resistance thermometer is shorted inside between  
 channels)

## RECORDING SPECIFICATIONS

Additional memory: CF card (Up to 8GB),  
 USB memory stick (Up to 8GB)  
 Not all USB memory stick is operated  
 Recording cycle: 100, 200, 500ms  
 1, 2, 3, 5, 10, 15, 20, 30s  
 1, 2, 3, 5, 10, 15, 20, 30, 60min  
 Logging data: Measured data --- File name (group name), time of day,  
 month and year of recording start, maker text, measured data,  
 alarm status/types  
 Setting parameter  
 Operation result data  
 Storing types: Binary/CSV  
 Storing methods: Manual start/stop (dedicated touch key operation)  
 Schedule (designation for time of day and date)  
 Trigger signal (alarm event, digital input)  
 \*Pre-trigger is selectable  
 Measuring numbers of pre-trigger --- Maximum 950 data  
 Recording group: Recording cycle 500ms or faster --- up to 3 groups of 12  
 points/group can be programmed  
 Recording cycle 1s or slower --- up to 5 groups of 44  
 points/group can be programmed  
 (Up to total of 100 points)

When 6 channels recorded in sampling mode (real data)

Recording cycle	256MB	512MB	1GB	2GB	8GB
1sec	126 days	253 days	1.4 yrs	2.8 yrs	11.2 yrs

When 12 channels recorded in sampling mode (real data).

Recording cycle	256MB	512MB	1GB	2GB	8GB
1sec	63.2 days	126 days	253 days	1.4 yrs	5.6 yrs

## COMPUTATION SPECIFICATIONS

Computation points: Maximum 44 points  
 Computation types: Arithmetic operations --- Addition, subtraction,  
 multiplication,  
 division, remainder, exponential  
 Comparison operations --- Equality, inequality, great, less,  
 equality /great, equality / less  
 Logical operations --- AND, OR, XOR, NOT  
 General functions --- Round-up, round-down, absolute  
 value, square root, exponent of e,  
 natural logarithm, common logarithm  
 Integration operations --- Analog integration, digital  
 integration  
 Channel data operations --- Measured data computation,  
 calculated data computation  
 Others --- Dew point, relative humidity, F-value  
 Remaining amount of CF card

## ALARM SPECIFICATIONS

Setups: Up to 4 alarms can be programmed per channel  
 Alarm types: Upper limit, lower limit, differential upper limit, differential lower  
 limit (deadband is selectable), abnormal data  
 Delay function: Setup range of alarm delay --- 1 to 1000 seconds  
 Alarm settings: AND/OR selectable  
 Alarm outputs: Refer to option specification

## DISPLAY SPECIFICATIONS

Display: 5.7"VGA TFT color LCD  
 Display types: Measured data display (Trend screen, Data screen, Bar-graph  
 screen)  
 Historical trend display (simultaneous display with Real-time  
 trend is available)  
 Information display (alarm display, marker list, file list)  
 Setting screen (alarm, computation, memory, system,  
 maintenance, communication, etc.)  
 Trend screen: 12 colors selectable  
 Display screen --- 5 screens (5 groups)  
 Display points --- Maximum 44 points/screen  
 Time axis direction --- Vertical or horizontal  
 Line width --- 1/3/5 dot selectable  
 Scale display --- 4 scales  
 Tag/data display --- Show/hidden selectable  
 Marker display  
 Circular trend  
 Data screen: Display screen --- 5 screens (5 groups)  
 Display points --- Maximum 44 points/screen  
 Display contents --- Measured value, channel/tag, unit, alarm  
 status  
 Bargraph screen: 12 colors selectable  
 Display screen --- 5 screens (5 groups)  
 Display points --- Maximum 44 points/screen  
 Display direction --- Vertical or horizontal  
 Scale display --- 1 scale  
 Information display: Alarm display (alarm activation/released history display)  
 Marker list  
 File list (group data file list display)  
 LCD back light: Auto/manual OFF function  
 Unit information (Model, Serial no., option, etc.)  
 Brightness --- 4 levels adjustment

\*The LCD display may contain some pixels that always or never illuminate, and the brightness of some areas of the display may appear uneven. There are typical LCD performance characteristics and do not constitute malfunctions.

## COMMUNICATION FUNCTIONS

### Network

Communication type: Ethernet (10BASE-T/100BASE-TX)  
 FTP server: Data file can be read from the network computer  
 FTP client: Transfer a data file to a network server  
 SNMP client: The time can be synchronized to the time of SNMP server  
 Web server: Conformed to HTTP1.0 --- Displays the alarm, information of  
 maintenance by browser software (Internet Explorer5.0 or later,  
 Netscape6.0 or later, Opera7 or later)  
 \*User's ID and password registration available  
 E-Mail: E-Mail notification at specified time for alarm activation  
 Report data at specified time is selectable from all registered  
 data  
 Notification address --- Maximum 8 contacts  
 DHCP client: Automatic IP address acquisition

### USB Communications

USB: Communication type --- USB1.1  
 Transfer systems --- Bulk transfer, control transfer  
 File transfer by connecting as removable disk drive



## CONNECTIVITY

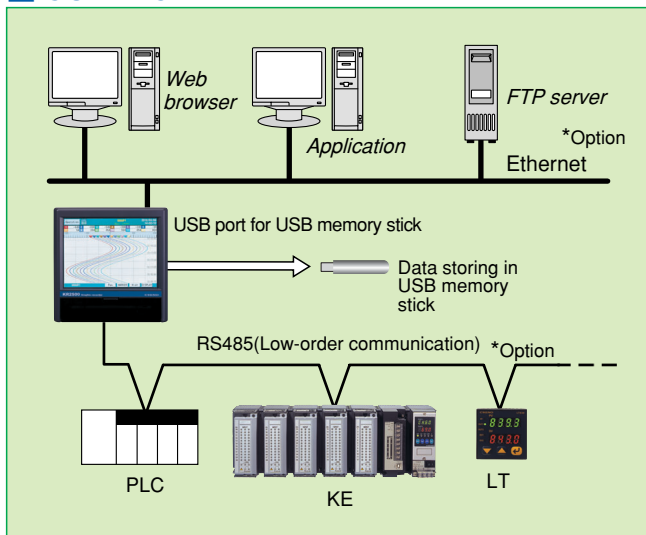

# KR2S SERIES

## PROGRAMMING/OPERATION SPECIFICATIONS

HOME settings: Simple recording settings --- Common setting to all channels  
Parameter programming for all channels together, recording cycle, selection settings

MENU settings: Input/computation programming --- Input parameter, computation parameter  
DISP settings --- Data channel parameter, group parameter, common parameter (combination display, trend vertical/horizontal)  
Alarm settings  
File settings (5 individual files) --- Storing method settings  
Marker text settings  
System settings --- Communication, clock, maintenance, key lock, password, screen, etc.

DISP operations: Operating screen selection --- Trend, data, bar-graph, historical trend, alarm display, maker list  
Display selection on each screen --- Group 1 to 5 selectable

## GENERAL SPECIFICATIONS

Rated power voltage: 100 to 240V AC (universal power supply) 50/60Hz  
Maximum power consumption: 35VA  
Reference operating condition:  
Ambient temperature --- 21 to 25°C,  
Ambient humidity --- 45 to 65%RH  
Power voltage --- 100V AC±1.0%  
Power frequency --- 50/60Hz±0.5%  
Attitude --- Left/right 0°, forward/backward 0°  
Warm-up time --- Longer than 30 minutes

Normal operating condition:  
Ambient temperature --- 0 to 50°C  
Ambient humidity --- 20 to 80%RH  
Power voltage --- 90 to 264V AC  
Power frequency --- 50/60Hz±2%  
Attitude --- left/right 0°, forward tilting 0°, Backward tilting 0° to 20°

Transport condition (at the packed condition on shipment from our factory):  
Ambient temperature --- -20 to 60°C  
Ambient humidity --- 5 to 90%RH (No dew condensation)  
Vibration --- 10 to 60Hz 0.5G (4.9m/S<sup>2</sup>) or less  
Impact --- 40G (392m/ S<sup>2</sup>) or less

Storage condition: Ambient temperature --- -20 to 60°C  
Ambient humidity --- 5 to 90%RH (No dew condensation)

Power failure protection:  
Flash memory and SDRAM stores the setting.  
Flash memory stores the data.  
Lithium battery back up the clock and parameter RAM for more than 5 years (provided that the daily operating hours is longer than 8hours).

Insulation resistance: Secondary terminals and protective conductor terminals --- 20MΩ or more at 500V DC  
Primary terminals and protective conductor terminals --- 20MΩ or more at 500V DC  
Primary and secondary terminals --- 20MΩ or more at 500V DC  
Primary terminals: power terminals (L,N), alarm output terminals  
Secondary terminals: measuring input terminals, digital input terminals, communications terminals

Dielectric strength: Secondary terminals and protective conductor terminals --- 1 minute at 500V AC  
Primary terminals and protective conductor terminals --- 1 minute at 1500V AC  
Primary and secondary terminals --- 1 minute at 2300V AC  
Primary terminals: power terminals (L,N), alarm output terminals  
Secondary terminals: measuring input terminals, digital input terminals, communications terminals

Case assembly material:  
Front bezel --- ABS resin  
Case --- Steel

Color: Front bezel --- Black (equivalent to Mussel N3.0)  
Case --- Painting color, gray (equivalent to Mussel N7.0)

Weight: 2.1kg (12 points input with full options)  
Mounting: Panel mounting

Terminal screws: Power terminals/protective conductor terminals/communications terminals --- M4.0  
Measuring input terminals/alarm output terminals/digital input terminals --- M3.5  
Communications terminals --- M3.0

## STANDARDS (CONFORMITY PENDING)

CE : EMC directive --- EN61326  
Class A  
EN61000-3-2  
EN61000-3-3  
Low voltage directive --- EN61010-1, EN61010-2-030

Protection: Conformed to IEC529 IP54 (recorder front bezel)

## OPTION SPECIFICATIONS

Options	Specifications
Mechanical relay alarm output	2 or 4 points (c contact)
Communications interface	High and low-order communications RS485
	Ethernet
Digital inputs	4 points

## MEASURING RANGES

Input type	Measuring range	Accuracy ratings
DC voltage	-13.80 to 13.80mV -27.60 to 27.60mV -69.00 to 69.00mV -200.0 to 200.0mV -500.0 to 500.0mV -2.000 to 2.000V	±0.1%±1digit
	(with built-in voltage divider) -5.000 to 5.000V -10.00 to 10.00V -20.00 to 20.00V -50.00 to 50.00V	
T/C	K -200.0 to 300.0°C -200.0 to 600.0°C -200 to 1370°C	±0.1%±1digit * -200 to 0°C: ±0.2%±1digit
	E -200.0 to 200.0°C -200.0 to 350.0°C -200 to 900°C	
	J -200.0 to 250.0°C -200.0 to 500.0°C -200 to 1200°C	
	T -200.0 to 250.0°C -200.0 to 400.0°C	
	R 0 to 1200°C 0 to 1760°C	±0.1%±1digit * 0 to 400°C: ±0.2%±1digit
	S 0 to 1300°C 0 to 1760°C	
	B 0 to 1820°C	±0.1%±1digit * 0 to 400°C: Out of accuracy ratings * 400 to 800°C: 0.15%±1digit
	N -200.0 to 400.0°C -200.0 to 750.0°C -200 to 1300°C	±0.15%±1digit * -200 to 0°C: ±0.3%±1digit
	W-WRe26 0 to 2315°C	±0.15%±1digit * 0 to 100°C: ±4%±1digit * 100 to 400°C: ±0.5%±1digit
	WRe5-WRe26 0 to 2315°C	±0.2%±1digit
	PtRh40-PtRh20 0 to 1888°C	±0.2%±1digit * 0 to 300°C: ±1.5%±1digit * 300 to 800°C: ±0.8%±1digit
	NiMo-Ni -50.0 to 290.0°C -50.0 to 600.0°C -50 to 1310°C	±0.2%±1digit
	CR-AuFe 0.0 to 280.0K	±0.2%±1digit * 0 to 20K: ±0.5%±1digit * 20 to 50K: ±0.3%±1digit
	PlatineII 0.0 to 350.0°C 0.0 to 650.0°C 0 to 1395°C	±0.15%±1digit
U -200.0 to 250.0°C -200.0 to 500.0°C -200.0 to 600.0°C	±0.15%±1digit * -200 to 0°C: ±0.3%±1digit	
L -200.0 to 250.0°C -200.0 to 500.0°C -200 to 900°C	±0.1%±1digit * -200 to 0°C: ±0.2%±1digit	
RTD	Pt100 -140.0 to 150.0°C -200.0 to 300.0°C -200.0 to 850.0°C	±0.1%±1digit * -140.0 to 150.0°C 700 to 850°C: ±0.15%±1digit
	JPt100 -140.0 to 150.0°C -200.0 to 300.0°C -200.0 to 649.0°C	±0.1%±1digit * -140.0 to 150.0°C: ±0.15%±1digit
	Pt50 -200.0 to 649.0°C	±0.1%±1digit
	Pt-Co 4.0 to 374.0K	±0.15%±1digit * 4 to 50K: ±0.3%±1digit

Note: The accuracy ratings are converted into the measuring range under reference operating condition. Thermocouple input does not contain reference junction compensation accuracy.  
 K,E,J,T,R,S,B,N:IEC584,JIS C1602-1995  
 W-WRe26,WRe5-WRe26,PtRh40-PtRh20,PlatineII,NiMo-Ni,  
 Cr-AuFe:ASTM Vol14.03  
 U(Cu-CuNi),L(Fe-CuNi):DIN43710  
 Pt100:IEC751(1995),JIS C1604-1997  
 JPt100:JIS C1606-1989

## APPLICATION SOFTWARE ZAILA (sold separately)

The software is applied for replay display/wave editing operation of recorded data in KR2S series. It has replay display of vertical/horizontal trend and circular trend function, and also analyzing function such as magnify/reduce/partially magnify of graphs and message insert.

### Display examples

Trend display window (vertical flow)

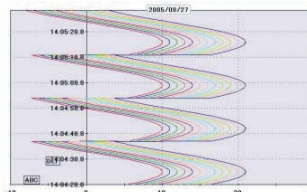

Trend display window (horizontal flow)

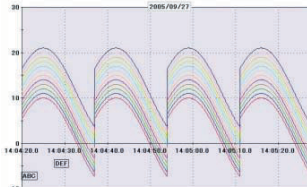

Trend display window (circular trend)

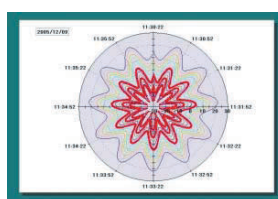

Bar-graph

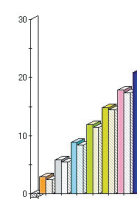

### Main functions

#### Trend display

Selectable from trend display window (vertical flow, horizontal flow) and circular trend display window.

#### Continuous replay display window

Trend is scrolled continuously (automatically).

Scroll changes by speed and renewal data no.

#### Data list display window

Displays registered data as list display.

#### Bar-graph

Displays by bar. Message can be inserted into bar-graph.

#### Data between markers

Displays date/time, time difference between 2 data, data difference, maximum, minimum, average, standard deviation and median among all data.

#### Alarm display

Points for alarm activation at each level are displayed on a trend graph.

#### Settings

Cursor, trend line, scale axis, time axis, title input on the graph, graph assistant and magnify/reduce/rotation of graphs

#### Data conversion

Exporting to Excel, and converting to CSV file or TEXT file are available.

## ENVIRONMENT

CPU	1GHz or faster
OS	Windows XP Home / XP Pro / VISTA / 7 *Internet Explorer 6.0 or later
Memory	256MB or more (512MB or more recommended)
Disk drive	CD-ROM drive: 1 drive or more Hard disk drive: Disk space of 1 drive or more for 100MB or more
Language	Japanese, English, Chinese (simplified and traditional characters), Korean

**■ TERMINAL ARRANGEMENT**

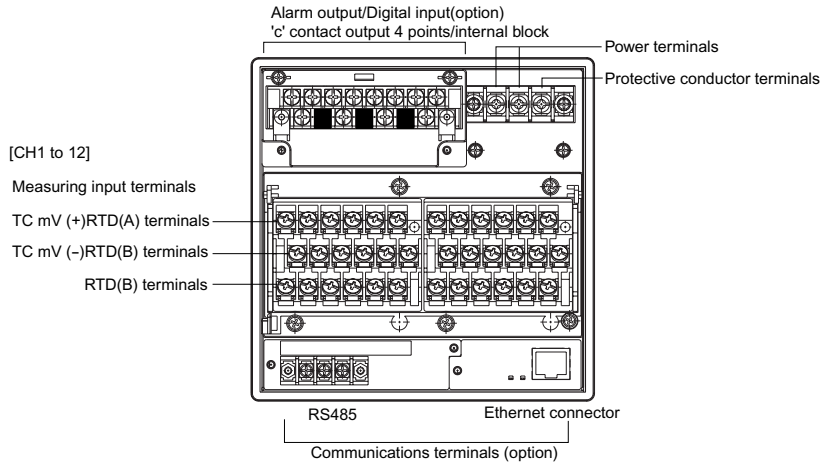

● Alarm relay output (4 points 'c' contact)

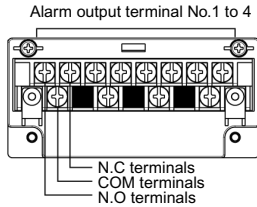

● Digital input (No voltage contact input 4 points)

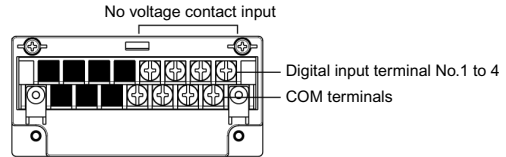

● Alarm relay output (2 points 'c' contact) + Digital input (No voltage contact input 2 points)

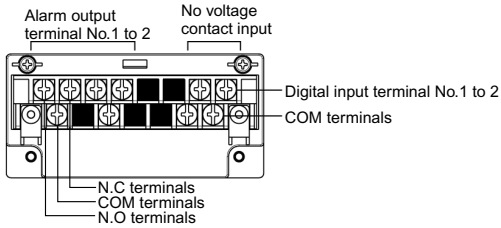

● Communication terminal

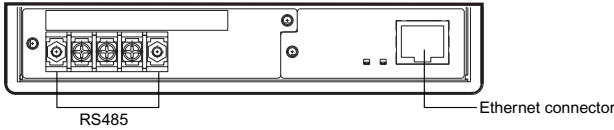

**■ DIMENSIONS**

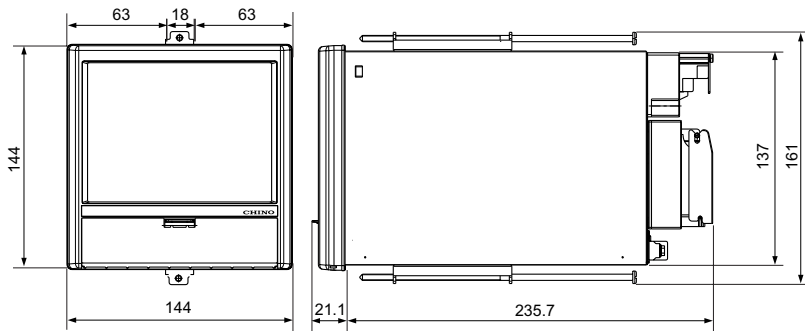

● PANEL CUTOUT

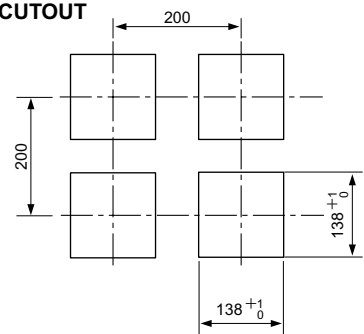

Unit: mm

Specifications subject to change without notice. Printed in Japan (I) 2012. 6

**CHINO CORPORATION**

32-8 KUMANO-CHO, ITABASHI-KU, TOKYO 173-8632  
Telephone : +81-3-3956-2171  
Facsimile : +81-3-3956-0915  
E-mail : inter@chino.co.jp  
Website : www.chino.co.jp/