

INST.No. INE-365E

**CHINO**

---

Graphic Recorder  
**KR2000**

General  
Instruction Manual

---

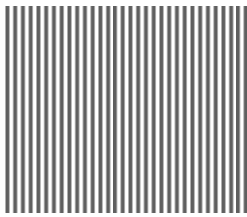

# **INSTRUCTIONS**

Thank you for purchasing the KR2000 series graphic recorder.  
Before using your new recorder, please be sure to read this instruction manual that will advise you on how to use the instrument correctly and safely and how to prevent problems.

**CHINO**

# CONTENTS

|   |     |  |       |
|---|-----|--|-------|
| <b>Preface</b> .....  | 1   | <b>12 HOME settings</b> .....                                      | 4 4   |
| <b>1 For safe use</b> .....   | 2   | 12.1 Setting with HOME settings .....                              | 4 4   |
| <b>2 Main features and functions</b> .....                                      | 4   | 12.2 Confirming the specifications with HOME settings screen ..... | 4 6   |
| <b>3 Before use</b> .....   | 5   | <b>13 MENU settings</b> .....                                      | 4 7   |
| 3.1 Exterior check .....  | 5   | 13.1 Setting MENU setting screen .....                             | 4 7   |
| 3.2 Model check .....   | 5   | 13.2 Input operation settings .....                                | 5 1   |
| 3.3 Checking attachments .....  | 6   | 13.3 Display settings .....  | 6 0   |
| <b>4 Installation</b> .....   | 7   | 13.4 Alarm settings .....  | 6 7   |
| 4.1 Mounting location .....   | 7   | 13.5 File settings .....   | 6 9   |
| 4.2 External dimensions .....   | 7   | 13.6 Totalizer reset settings .....                                | 7 3   |
| 4.3 Method of mounting the panel .....  | 8   | 13.7 Schedule settings .....                                       | 7 4   |
| <b>5 Connections</b> .....  | 9   | 13.8 Marker text settings .....                                    | 7 5   |
| 5.1 Terminal board arrangement .....  | 9   | 13.9 Memory operation .....  | 7 6   |
| 5.2 Precautions while connections .....   | 1 1 | 13.10 Network settings .....                                       | 7 7   |
| 5.3 Connection of power and protective conductor terminals .....                | 1 2 | 13.11 System settings .....  | 8 6   |
| 5.4 Connection of measuring input terminal .....                                | 1 3 | <b>14 Setting/Displaying on WEB screen</b> .....                   | 9 2   |
| 5.5 Connection of alarm output terminals (option) .....                         | 1 4 | 14.1 Display and settings of the Web screen .....                  | 9 2   |
| 5.6 Connection of digital input terminals and function selection (option) ..... | 1 6 | <b>15 Read the recorded data using USB</b> .....                   | 9 9   |
| 5.7 Connection of communication I/F terminal (partly option) .....              | 1 7 | 15.1 Outline .....   | 9 9   |
| <b>6 Operation</b> .....  | 2 1 | 15.2 Operation environment .....                                   | 9 9   |
| <b>7 Name of each part</b> .....  | 2 2 | 15.3 Access to data file .....                                     | 9 9   |
| 7.1 Name of front panel and its major functions .....                           | 2 2 | <b>16 Low order communications(read)</b> .....                     | 1 0 1 |
| 7.2 Name of the keys and their functions.....                                   | 2 3 | 16.1 Outline .....   | 1 0 1 |
| 7.3 Method of inputting the characters .....                                    | 2 4 | 16.2 Procedure of connection to low order instrument .....         | 1 0 2 |
| <b>8 Screen switching method</b> .....  | 2 6 | <b>17 Low order communications(write)</b> .....                    | 1 0 7 |
| <b>9 Name and functions of operation screen</b> .....                           | 2 8 | 17.1 Outline .....   | 1 0 7 |
| 9.1 Common operations of operation screen .....                                 | 2 8 | 17.2 Register to the instrument .....                              | 1 0 8 |
| 9.2 Status bar .....  | 3 0 | <b>18 Scale calibration</b> .....                                  | 1 0 9 |
| 9.3 Real time trend screen .....  | 3 1 | 18.1 Scale calibration.....  | 1 0 9 |
| 9.4 Bar graph screen .....  | 3 2 | 18.2 Calibration environment .....                                 | 1 0 9 |
| 9.5 Numeric display screen .....  | 3 2 | 18.3 Preparation .....   | 1 0 9 |
| 9.6 Historical trend screen .....   | 3 3 | 18.4 Connections .....   | 1 1 0 |
| 9.7 Dual trend screen .....   | 3 4 | 18.5 Zero and span adjustment .....                                | 1 1 2 |
| 9.8 Alarm display screen .....  | 3 4 | <b>19 Recommended parts replacement interval</b> .....             | 1 1 6 |
| 9.9 Internal memory screen .....  | 3 5 | 19.1 Operating conditions .....                                    | 1 1 6 |
| 9.10 Card file screen .....   | 3 7 | 19.2 Reference of parts replacement intervals.....                 | 1 1 6 |
| 9.11 Marker list screen .....   | 3 7 | <b>20 Troubleshooting</b> .....                                    | 1 1 7 |
| <b>10 Initial settings</b> .....  | 3 8 | <b>21 Specifications</b> .....                                     | 1 1 8 |
| <b>11 Flow chart of HOME settings &amp; MENU settings</b> .....                 | 4 2 | <b>Appendix A. Report application (Sample)</b> .....               | 1 2 1 |

# PREFACE

Thank you for purchasing the KR2000 series graphic recorder. Before using your new recorder, please be sure to read this instruction manual that will advise you on how to use the instrument correctly and safely and how to prevent problems.

## 1. Separate instruction manuals

This instruction manual describes the optional specifications of alarm output and report application of appendix as well as the operation of standard specifications. When the instrument is with the higher order or low order serial communications interfaces (option), the separate instruction manual for communications interfaces is attached. For other options you specified, their instruction manuals are attached respectively. Read these instruction manuals together with this manual.

## 2. Request

- Request to instrumentation engineers, constructors, and sale agents  
Make sure to deliver this instruction to the operator of this instrument.
- Request to the operator of this instrument  
This instruction manual is necessary for maintenance, too. Keep this manual with care until the instrument is discarded.

## 3. Attention while unpacking

- Do not drop the recorder when take it out of the box
- When transporting this recorder, pack the instrument in the box and then put it with cushions in another box. We recommend keeping the box for transport.
- When not using the recorder for a while after taking it from the panel, put the recorder in the box and store at room temperature and in a dust free atmosphere.

## 4. Disposal

Separate the box, plastic bag, and shock material the recorder is packaged in according to the garbage collection method of the each community, and please cooperate to recycle.

|         |   |
|---------|---|
| Caution | 1. A small amount of hazardous substance below the specified level with RoHS directive is included in this recorder.    |
|         | 2. When disposing the controller always request a professional to do it or contact your dealer or our nearest office.   |
|         | 3. This recorder includes a lithium battery. When disposing the lithium battery always request a professional to do it. |

# 1 For safe use



This section "FOR SAFE USE" has been compiled to promote the correct use of the instrument in order to prevent human injury or damage to property before they occur. Please read the following information carefully and be sure to observe the warnings and cautions in it.

## 1. Preconditions for use

This instrument is designed for indoor use by mounting it on an indoor instrumentation panel.





## 2. Labels on this instrument

The following labels are used for safe use.

| Label   | Name                          | Meaning   |
|---|-------------------------------|---|
|  | Alert symbol mark             | Indicates the location that should refer to the manual in order to prevent an electric shock and injury.                                |
|  | Protective conductor terminal | A terminal is provided for connection to the protective conductor of the power supply facility for the prevention of an electric shock. |

## 3. Symbols in this manual

The cautions to be observed for preventing the damage of this instrument and unexpected accidents are sorted by the following symbols according to their importance degrees for enabling operators to use this instrument safely.

|  |   |
|--|---|
|  <b>Warning</b>   | The nonobservance of information under this symbol may result in hazardous, critical or serious injury to the user.   |
|  <b>Caution</b>   | The nonobservance of information under this symbol may result in a hazardous situation or a light injury to the user or in physical damage to the property. |
|  <b>Remarks</b>   | This symbol shows a caution when the instrument does not function as specified or when such a possibility exists.   |
|  <b>Reference</b> | This reference serves as a supplement for handling and operation, and it may be convenient for the user.  |

# ⚠ WARNINGS

This paragraph covers important warning for safety to be observed before reading the instructions. Fully understand the following warning before reading this manual. These warnings are important for preventing the damage to human bodies as well as accidents.

## 1. Switch and overcurrent protective device

The KR2000 series graphic recorder is not provided with a replaceable overcurrent protective device. Prepare a switch and an overcurrent protective device for the power supply (circuit breakers, circuit protectors or the like) within 3m of this recorder in a location where the operator can access easily. Use a switch and an overcurrent protective device conforming to IEC947-1 and IEC947-3.

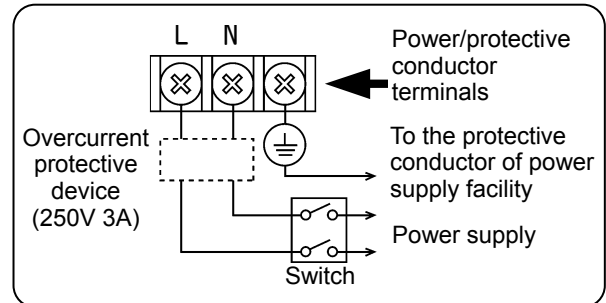

## 2. Be sure to ground this recorder

Before turning the power on, connect the protective conductor terminal of this recorder to the protective conductor of the power supply facility. In order to prevent an accident by electric shock, do not disconnect this connection during operations.

### Reference → Fuse in the power supply

The following fuse is mounted in the power supply unit of this recorder for safety use. However, this fuse is not replaceable.

Manufacturer : Nippon Seisen Cable., Ltd.  
Model : FCT 250V 3A 8H02

## 3. Before turning on the power supply

In order to ensure safety, before turning on the external power switch make sure that the power voltage is within the range indicated on the power supply label.

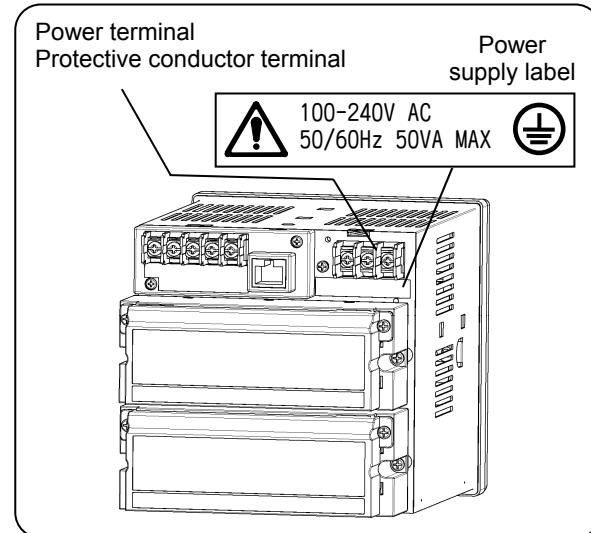

## 4. Don't repair or modify this recorder

Make sure that any persons other than service engineers approved by CHINO CORPORATION do not repair or modify this instrument by replacing parts. Otherwise it may be damaged or will not function normally or an accident such as electric shock may occur. For ordinary operation, it is not necessary to pull out the internal unit.

## 5. Use this recorder following this instruction manual

Use this recorder correctly and safely by following this instruction manual. CHINO CORPORATION will not be responsible for any injury, damage, lost profit or any other claim, which may result from its wrong use.

## 6. Turn off the power supply if an abnormal symptom occurs

Turn off the power supply immediately and contact your local CHINO's sales agent if any abnormal odor, noise or any smoke occurs, or if this recorder becomes high temperature that is too hot to be touched.

## 2 Main features and functions

Besides measuring temperature and various industrial quantities of multi channels and displaying real time trends, bar graphs, numeric value, etc. in various formats on 5.6 inch TFT color LCD, this recorder can store data into the internal memory or a memory card (a CF card) and replay them if required. Stored data can be used using commercial software like EXCEL, etc. Data analysis software is also available.

|                                       |  |
|---------------------------------------|--|
| Easy management of measurement result | The monitoring of measurement results is easy since the data are displayed on various formats of screens. The precious data in the CF card can be read and the stored data can be managed using commercial software like EXCEL (Registered trademark of Microsoft Corporation), etc.   |
| Various screen displays               | Real time trends, bar graphs, data (in a table format) and combined displays of "real time trends and bar graphs", "real time trends and numeric values" and "real time trends and historical trends" can be arbitrarily selected and monitored with most suitable screens to meet your requirements. As alarm display screen displaying past alarm activation status collectively and a marker list screen are also available.<br>In addition, up to 5 files can be registered. With easy operation, these screens can be switched. |
| Various memory functions              | Start/stop of data storage can be executed by arbitrary condition settings like key operation, alarm settings, time settings, etc. and the simultaneous storage to maximum 5 files can also be executed. In normal operations, data are stored into the internal memory and can be saved on the CF memory card.  |
| Analog recorder feeling               | As the trend screen displays data on a chart with scale plates and pointers, the data can be monitored like analog recorder.   |
| Marker function                       | Marker and marker text (alphanumeric characters, maximum 30 characters) can be written on the trend screen. A marker text is written arbitrarily, and also 50 types of marker texts can be registered in advance and these marker texts can be written with key operations. The marker texts can be written on the historical trend screen (replay), too. Markings only without marker texts are also available.   |
| MODBUS communication                  | Parameter settings, data acquisition and operation can be executed with the optional high order communication. As communication protocol utilizes MODBUS, this recorder can communicate with program indicator equipped with the MODBUS protocol without creating any communication software and the configuration of a system is easy. (MODBUS: The registered trademark of Schneider Electric SA)  |
| Consumables not required              | Since consumables like charts, pens and inks as used in recorders are not required, this recorder is clean and less time consuming.  |
| Easy setup                            | The easy interactive parameter setting offers parameter settings by selecting a setting item from the menu screen with key or touch-panel operation and then by opening a window.<br>Also the operation can be executed easily with the required parameter settings on the "Simple settings (HOME)" screen.  |
| Software package is available         | Data analysis can be executed easily on the PC as software package for data analysis is available.<br><br><ul style="list-style-type: none"> <li>• Software for analysis : (Windows98,Me,2000,XP version)</li> </ul>   |

# 3 Before use

Check the following items before using the recorder. If something is wrong, contact your local CHINO's sales agent.

## 3.1 Exterior check

Check that the instrument is not broken on the outer side.

## 3.2 Model check

The model number and serial number of the KR 2000 series graphic recorder can be confirmed by the label on the upper side of the case.

Check the model of your instrument from the model code before use.

### ■ Model code

KR21

Model (Check with model code)

Serial No.



- Type (Fixed as 2): 2 types
- Input type (Fixed as 1): Universal input  
(DC voltage, thermocouple, resistor thermometer)
- Measurement points/Sampling rate
  - 60: 6-point input /100ms
  - 20: 12 point input /100ms
  - 61: 6 point input /1s
  - 21: 12-point input /1s
- Communication interface (Option)
  - N: None
  - R: High order (RS232C /RS485) switchable
  - Q: High order (RS232C /RS485) + Low order (RS485)
- Alarm output, Digital input
  - 0: None
  - 1: Mechanical relay output (12 points 'a' contact)
  - 2: Mechanical relay output (6 points 'c' contact)
  - 7: Digital input (8 points) + Alarm relay output (8 points)
- Power supply,
  - A: 100V – 240VAC

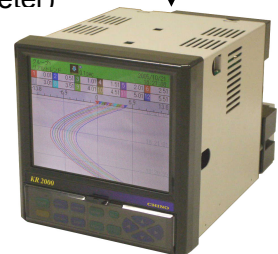

\* When the recording cycle is set less than 0.5 seconds at the KR2161/2121, input channel numbers become 4 points automatically.

### 3.3 Checking attachments

Package contains the following attachments. Please confirm.

| Parts name           | Quantity | Remarks  |
|----------------------|----------|--|
| ① Instruction manual | 1        | INE-365□ (For KR 2000 series graphic recorder) CD-ROM                            |
|                      | (1 copy) | INE-802□ (Communications interfaces)   |
|                      |          | INE-366□ (Mounting/connections edition) A4 19 pages                              |
|                      | 1        | RZMC-01-□ (CF card)  |
| ② Mounting bracket   | 2        | For panel mounting   |
| ③ Terminal screw     | 5        | For M3.5, input terminal and alarm (digital input) terminal (Spares for missing) |
| ④ CF card            | 1        | RZ-CMC128 (128MB)  |

① Operation manual

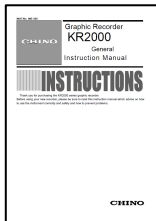

③ Terminal screws

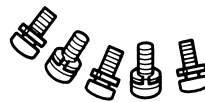

② Mounting bracket

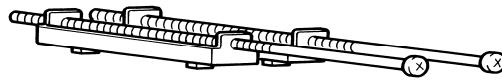

④ CF card





# 4 Installation

## 4.1 Mounting location

In order to avoid unfavorable effects on measurement accuracy and recording operation, mount the KR 2000 series graphic recorder at the following locations.

### 1) Industrial environment

Select a place away from a source generating electric field and/or magnetic field and where mechanical vibrations/shock is not existed.

- Over voltage category..... II
- Altitude.....2000m or less
- Pollution degree.....2
- Place of use.....Indoor

### 2) Ambient temperature/humidity

Keep away from direct sunlight and so not close an area around the KR 2000 series graphic recorder to avoid temperature increase.

- Place with stable ambient temperature of around 23°C and humidity 50%RH
- Place not exposed to hot drafts (50°C or more) for avoiding deformation of the front panel
- Place where there are no wind and no heat source near terminals for avoiding measurement errors.

### 3) Atmosphere

- Avoid a place where flammable gases exist.
- Avoid a place with dust, smoke, vapors etc.

### 4) Mounting angle

- Lateral tilting...0°
- Longitudinal tilting...Forward tilting: 0°, Backward tilting: 0-20°

Mounting angle other than the above angles will have unfavorable effects on recording operation.

## 4.2 External dimensions

The following figure shows the dimensions of KR 2000 series graphic recorder with its mounting brackets.

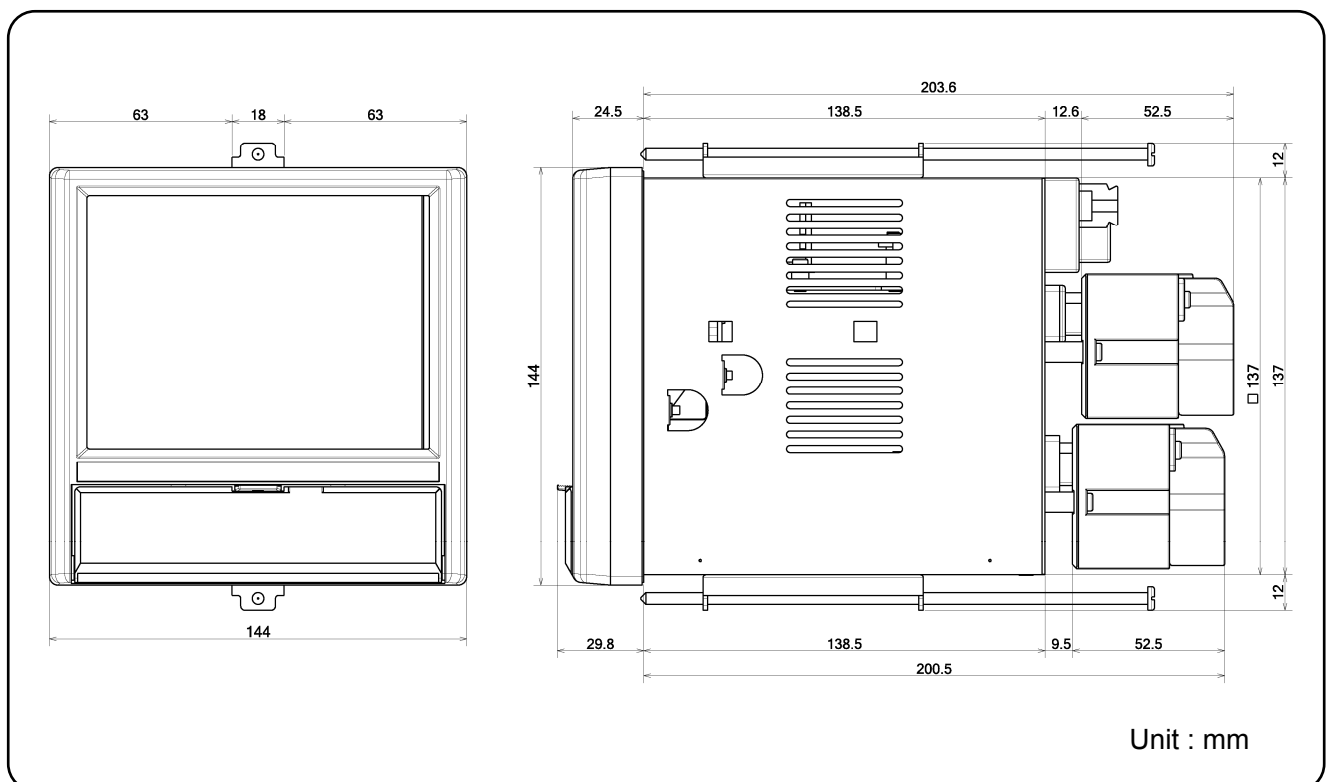

## 4.3 Method of mounting the panel

### Warning

■ Mount on the panel and use

- (1) The KR2000 series graphic recorder has been designed to be mounted on an indoor instrumentation panel.
- (2) Use a panel made of a steel plate of 2mm to 6mm in thickness or a panel equivalent in strength.

#### 1) Panel cut size

● Minimum interval for installation of multiple instruments

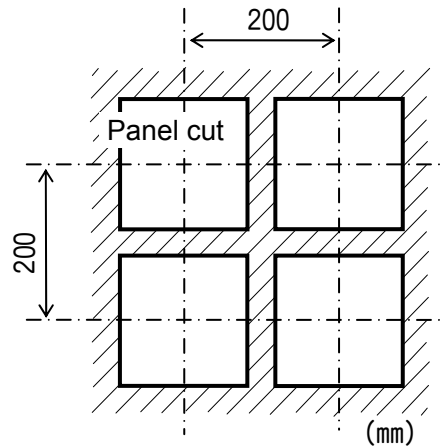
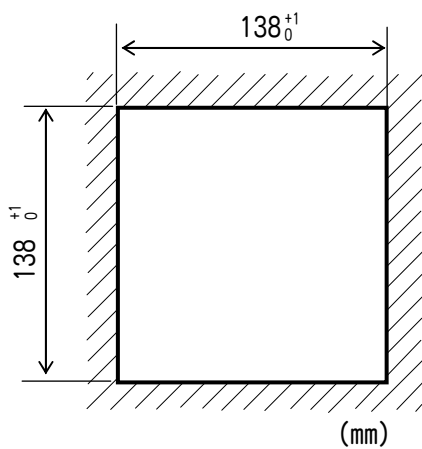

#### 2) Mounting method

- (1) Insert the KR 2000 series graphic recorder in the panel cutout from the front of the panel.
- (2) Fixed the KR 2000 series graphic recorder using mounting brackets (Screw tightening torque: 1.0 N•m). Mounting brackets are fixed on the top and bottom.

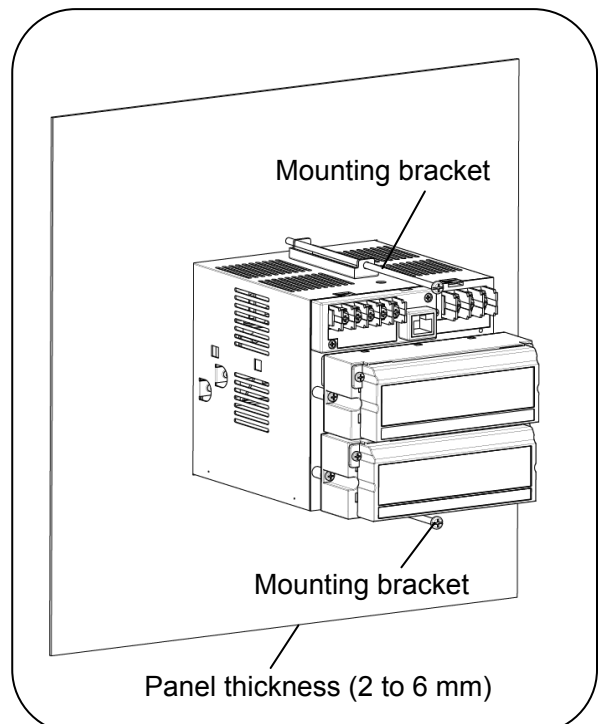

# 5 Connections

## 5.1 Terminal board arrangement

The following diagram shows the terminal board arrangement in which option (alarm relay output [12 points 'a' contact], communication interface) are mounted. Connector for Ethernet is a standard mounting.

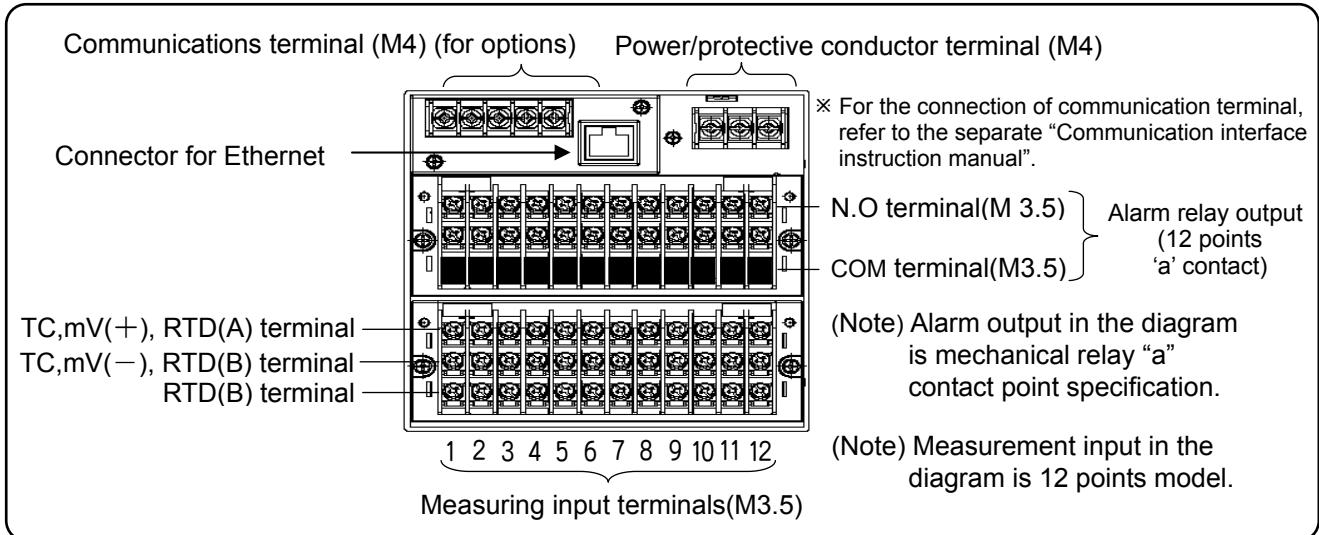

The following diagram shows the terminal board arrangement in which option (alarm relay output [6 points 'c' contact], communication interface) are mounted. Connector for Ethernet is a standard mounting.

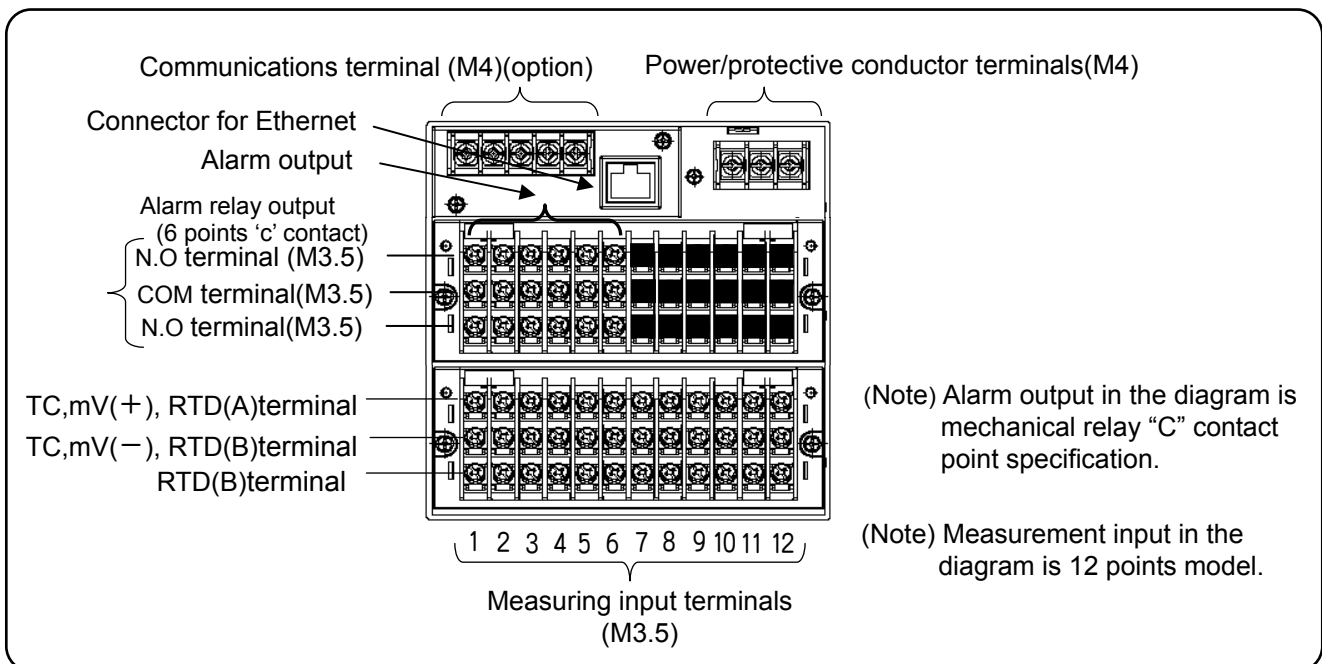

Following figure is terminal board diagram for option (digital input [8 points] + alarm MOS relay output [8 points]) in KR2000, equipped with communication interface. Connector for Ethernet is a standard mounting.

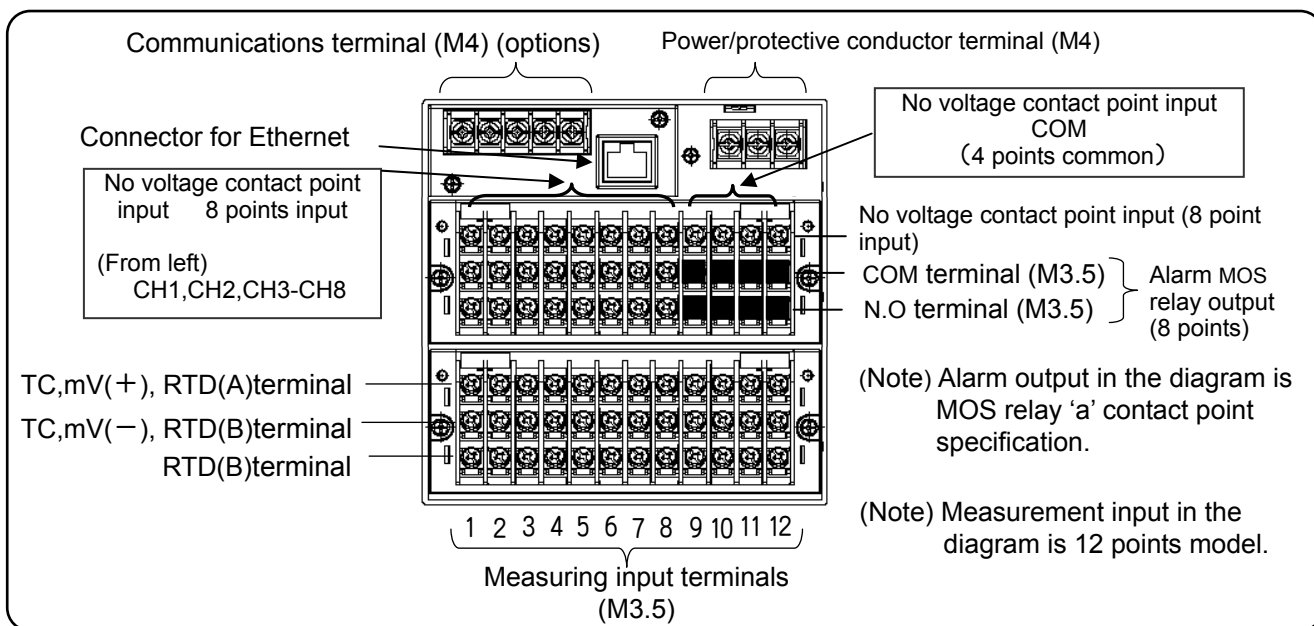

## ⚠ Warning

### ■ Alert symbol marks ( ⚠ ) and places

The alert mark ( ⚠ ) is pasted at danger places where may causes electric shock. (See the following table).

| Name of terminals             | Power terminals               | Measurement input terminals  | Mechanical relay 'c' contact alarm terminals | MOS relay, mechanical relay 'a' contact alarm terminals |
|-------------------------------|-------------------------------|------------------------------|--|---|
| Places marked with the symbol | Lower left of power terminals | Upper left of terminal cover | Upper left of terminal cover                 | Beside alarm terminals                                  |

### Remarks ➤ Input terminal and alarm terminal blocks are removable

The input terminal block and alarm terminal block (including the contact terminal block) are removable for easy connections.

- (1) Each terminal block can be removed by removing two mounting screws.
- (2) Each terminal block is connected to the recorder by a connector.

### ⚠ Caution

#### ■ Turn off the power supply in advance

For mounting or dismantling the terminal block, turn off the external power switch to prevent the electric circuits from being damaged.

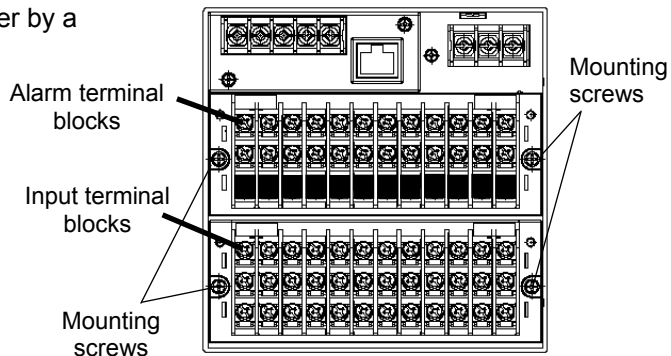

### Notes ➤ Replacement of thermocouple input terminal block

Thermocouple input terminal block cannot be replaced by terminal block of other instrument. If replaced measurement error occurs.

## 5.2 Precautions while connections

Observe the following cautions during connections for securing safety and reliability.

### 1) Power supply

Use a single-phase power supply having a stable voltage without any waveform distortion for the purpose of preventing wrong operations.

#### **Warning**

##### (1) A switch and an overcurrent protective device

Prepare a switch and an overcurrent protective device (3A) to the power supply for preventing an electric shock accident during connection work. This recorder is not provided with any replaceable fuse.

##### (2) Turn off the power supply before connections

Be sure to turn OFF the power supply before connecting cables to the power and the input/output terminals to prevent an electric shock.

### 2) Keep the input/output connections away from a high voltage power circuit

Don't place the input/output cables close or in parallel with any strong power circuits including power line. Place the cables 50 cm or more away from high voltage power circuits when they are placed close or in parallel to other circuits.

### 3) Keep the thermocouple input away from a heat source

For thermocouple inputs, keep the input terminals away from a heat source (a heating body) to reduce a reference junction compensation error. Don't expose the input terminals to direct sunlight, etc.

### 4) Keep all connection cables away from noises

Keep all connection cables away from noise source as far as possible, otherwise unexpected malfunction may occur. Provide a solution if the cables cannot be separated from a noise source due to unavoidable circumstances.

|                     |  |
|---------------------|--|
| Major noise sources | <ul style="list-style-type: none"> <li>● Electromagnetic switch, etc.</li> <li>● Power line having waveform distortion</li> <li>● Inverter</li> <li>● Thyristor regulator</li> </ul> |
| Counter measures    | Insert noise filters between power terminals and input/output terminals. A CR filter is often used.  |

### 5) Use crimp style terminals

(1) Fix crimp style terminals to termination of connection cables for preventing the looseness or disconnection of terminals and a short-circuit failure between terminals.

(2) Use the crimp style terminals with insulation sleeve for preventing an electric shock.

### 6) Unused terminals

Don't use any unused terminals for relaying; otherwise the electric circuits may be damaged.

#### **Warning**

■ Secure the connected cables properly.

Secure the connected cables so as not to allow them to be hooked by a person or a substance, otherwise the connections may be cut and disrupted that may cause an electric shock or other accidents.

Kinds of terminals and terminal process

| Terminal block  | Screw diameter | Tightening torque | Termination (Unit: mm)  |
|---|----------------|-------------------|---|
| Power and protective conductor and communication terminal | M4             | 1.2N.m            | <p>Type O</p> <p>Less than 8.5    More than 4.3    t:0.8</p> <p>With an insulation sleeve</p>   |
| Terminal other than described above                       | M3.5           | 0.8N.m            | <p>Type O                      Type Y</p> <p>Less than 8    More than 3.7    t:0.8                      t:0.8</p> <p>Less than 8    More than 3.7    t:0.8</p> <p>With an insulation sleeve    With an insulation sleeve</p> <p>※As far as possible use Type O.</p> |

## 5.3 Connection of power and protective conductor terminals

### 1) Power and protective conductor terminals

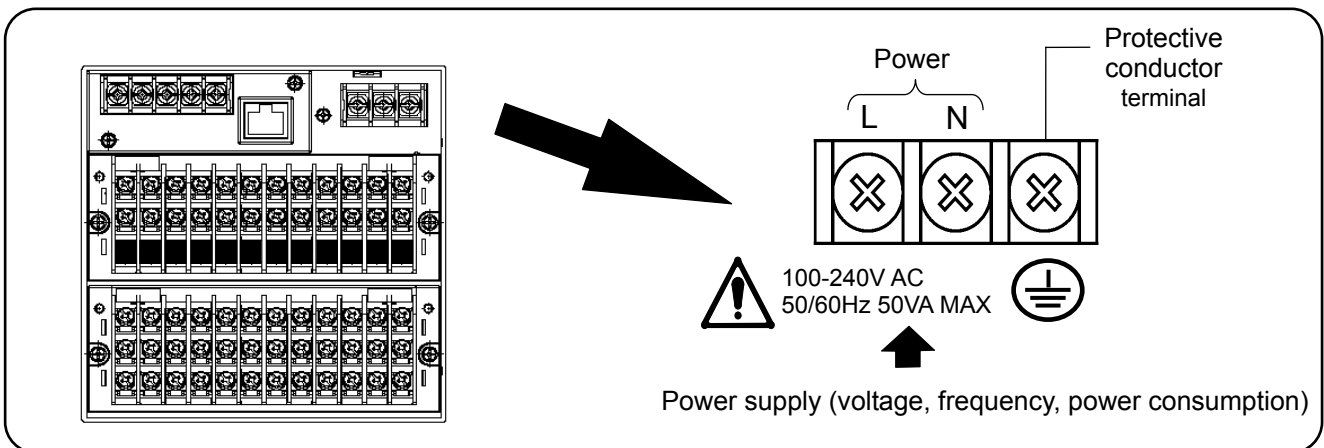

### Warning

#### ■ Turn off the power supply

Be sure to turn off the power supply before connecting the cable to the power supply and protective conductor terminals to prevent an electric shock.

### 2) Connection of power terminals

For connection to the power terminals, use a 600 V PVC insulated cable terminated by the crimp style terminals with insulation sleeve.

Note) Use the cords approved by the following standards.

- (1) IEC 227-3
- (2) ANSI/UL817
- (3) CSA C22.2 No.21/49

### 3) Connection of protective conductor terminal

Be sure to connect this terminal to the protective conductor of the power supply facility. For this connection, use a cable terminated by the crimp style terminals with insulation sleeve.

• Grounding wire:

Copper wire 2 mm<sup>2</sup> or more (green/yellow)

### Warning

#### ■ mark at power terminals

A voltage of 100 to 240 V AC is applied to the power terminals after connection. Be sure to mount the power terminal cover to prevent an electric shock.

#### Notes L/N indication of power terminals

This indication conforms to the CSA standard, Canada. The live side of the single-phase AC power supply is indicated as L, and the neutral side is indicated as N. Observe the L and N connections for obtaining satisfactory performance.

### Caution

#### ■ Be careful with the power voltage and noise

The power voltage of this instrument is indicated beside the power terminals.

Don't apply any voltage other than indicated; otherwise a malfunction may result.

If noise is generated at the power supply, provide a noise reduction transformer, etc.

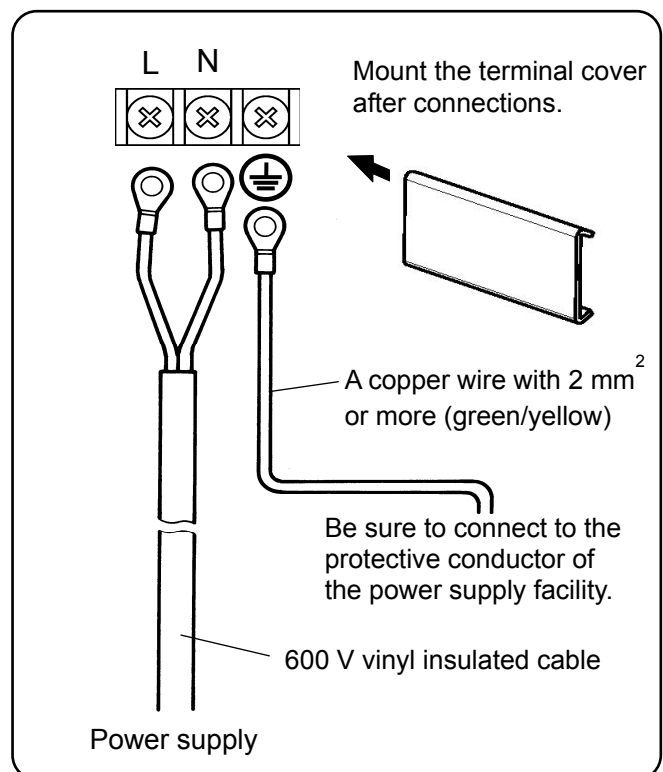

## 5.4 Connection of measuring input terminals

### 1) Measuring input terminals

Be sure to turn off the power supply to prevent an electric shock.

- For the connections to the input terminals, use cables terminated by the crimp style terminals with insulation sleeve

**⚠ Caution**

**■ Allowable input voltage**

| Input type                   | Allowable input voltage |
|------------------------------|-------------------------|
| Voltage, thermocouple input  | $\pm 10\text{VDC}^*$    |
| Resistance thermometer input | $\pm 6\text{VDC}$       |

\*  $\pm 60\text{ V DC}$  with channel settings to the  $\pm 5\text{ V}$  or higher range.

### 2) Connections of DC voltage (current) input

Use twisted cables for instrumentation as the input cables for the purpose of suppressing noises. For current inputs, mount shunt resistors to the channels to be measured before connections.

**● DC voltage (Current) input**

**⚠**

Twisted cable for instrumentation

DC voltage input

**⚠ Warning**

**■ ⚠ mark of measuring input terminals**

A high voltage may be applied to the measuring input terminals due to common mode noises. The allowable noise value is lower than 30 V AC or lower than 60 V DC. Make sure that the noises are lower than the allowable values. Mount the terminal cover after connections for the purpose of preventing an electric shock and to protect the input wires. In the case of thermocouple input, the mounting of the terminal cover can reduce the reference junction compensation error.

### 3) Connection of thermocouple (TC) inputs

Be sure to use thermocouple wires (or extension wires) to the input terminals of this recorder. If a copper wire is used halfway, a noticeable measuring error occurs. Don't use a pair of thermocouple wires in parallel with other instruments (controller, etc.), otherwise a malfunction may occur.

**● Thermocouple (TC) input**

**⚠**

Red (+)

White (-)

Compensation lead wire

Thermocouple

### 4) Connection of resistance thermometer (RTD) input

Use a 3-core cable where each lead wire has an equal resistance value. Don't use one resistance thermometer in parallel with other instruments (controller, etc.).

**● Resistance thermometer input**

**⚠**

A

B

B

3 core cable  
(Same diameter, same length)

Note: The resistance of each cable is less than 10  $\Omega$ . All the 3 wires should be of the same resistance value.

Resistance thermometer

**Notes** → Isolation of measured input terminal

TC, mV(+), RTD(A) terminal and TC, mV(-), RTD(B) terminal are insulated each channels but RTD(B) terminal is short-circuited between channels. KR21\*0 is short-circuited between channel 1 to 4, 5 to 8, 9 to 12, and KR21\*1 is short-circuit all channel.

## 5.5 Connection of alarm output terminals (option)

This is for the recorder with alarm output terminals (option).

### 1) Alarm output terminal

The terminal arrangement depends upon the type of alarm output.

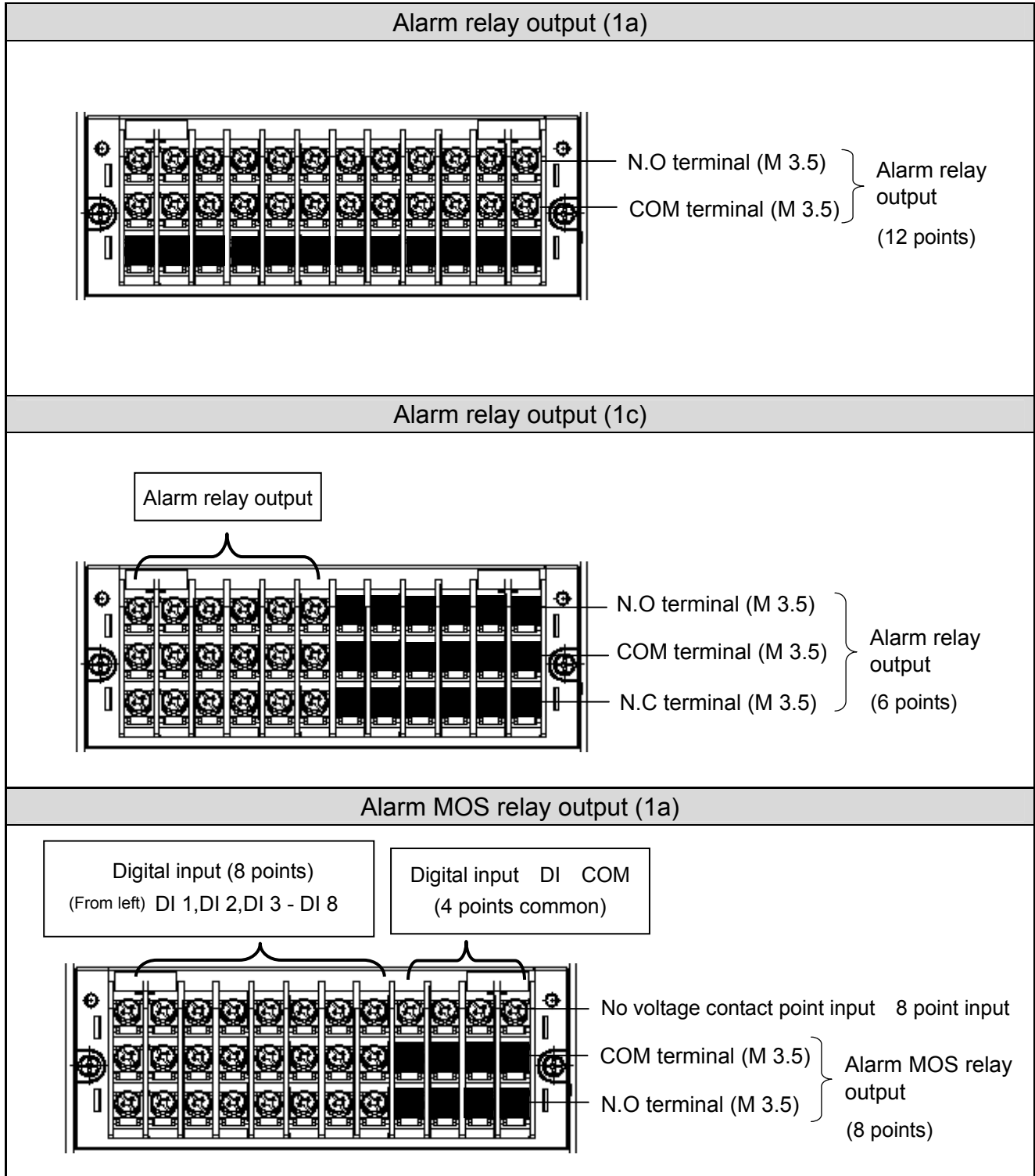



## 2) Connections

Turn off the power supply and buffer relay power supply before connections to prevent an electric shock.

(1) Connect cables to the load via a buffer relay.

(2) Use cables with the crimp style terminals with insulation sleeves for the alarm output terminals.

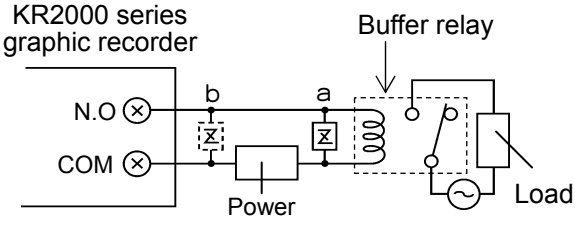
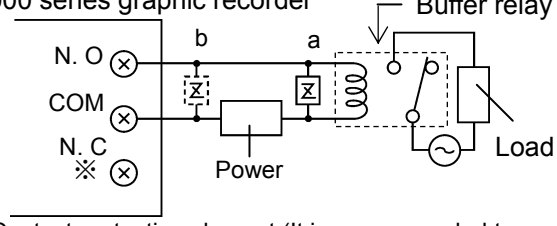
| Example of MOS relay and mechanical relay 'a' contact output  | Example of mechanical relay 'c' contact output   |
|---|--|
|  <p>⊗ : Contact point protective element (It is recommended to mount this element on the a side)</p> |  <p>⊗ : Contact protective element (It is recommended to mount this element on the a side)<br/>N.C terminal - Open relay contact at alarm activation that is the reverse action to N.O terminal.</p> |

### Warning

■  mark of alarm output terminals  
Connect a load not exceeding the specified contact capacity to the alarm output terminals. A buffer relay power supply is applied to the alarm output terminals after connections. Do not touch these terminals since an electric shock will occur. Be sure to mount the terminal cover after connections.

### Caution

■ Take a safety measure  
An alarm output of this recorder may become defective caused by wrong operation, failures, and other abnormal inputs. Take a safety measure against an output failure before use as occasion calls.

## 3) Precautions for connection

Be careful with the following cautions for connections.

| Item   | Contents   |                |                                |                |                                |          |       |       |          |       |       |         |       |       |
|--|--|----------------|--------------------------------|----------------|--------------------------------|----------|-------|-------|----------|-------|-------|---------|-------|-------|
| Contact rating of MOS relay outputs  | <ul style="list-style-type: none"> <li>Maximum voltage...240V (AC,DC)</li> <li>Maximum current...50mA (AC,DC) * Irrespective of load types (Minimum load)</li> </ul>   |                |                                |                |                                |          |       |       |          |       |       |         |       |       |
| Contact rating of Mechanical relay outputs (Common to 'a' contact and 'c' contact) | <table border="1" data-bbox="563 1337 1201 1473"> <thead> <tr> <th>Power supply</th> <th>Resistive load</th> <th>Inductive load</th> <th rowspan="4">(Minimum load)<br/>100μA100mVDC</th> </tr> </thead> <tbody> <tr> <td>100 V AC</td> <td>0.5 A</td> <td>0.2 A</td> </tr> <tr> <td>240 V AC</td> <td>0.2 A</td> <td>0.1 A</td> </tr> <tr> <td>30 V DC</td> <td>0.3 A</td> <td>0.1 A</td> </tr> </tbody> </table>                 | Power supply   | Resistive load                 | Inductive load | (Minimum load)<br>100μA100mVDC | 100 V AC | 0.5 A | 0.2 A | 240 V AC | 0.2 A | 0.1 A | 30 V DC | 0.3 A | 0.1 A |
| Power supply   | Resistive load   | Inductive load | (Minimum load)<br>100μA100mVDC |                |                                |          |       |       |          |       |       |         |       |       |
| 100 V AC   | 0.5 A  | 0.2 A          |                                |                |                                |          |       |       |          |       |       |         |       |       |
| 240 V AC   | 0.2 A  | 0.1 A          |                                |                |                                |          |       |       |          |       |       |         |       |       |
| 30 V DC  | 0.3 A  | 0.1 A          |                                |                |                                |          |       |       |          |       |       |         |       |       |
| Mounting of contact protective element Z   | <ul style="list-style-type: none"> <li>Mount a contact protective element conforming to the buffer relay. The MOS relay is broken, if a signal exceeding the contact rating is applied even momentarily.</li> <li>To prevent a malfunction being caused by a light load, the most effective mounting position for the element is on the coil side of the buffer relay ('a' in the connection diagrams under (2) on 5.5)</li> </ul> |                |                                |                |                                |          |       |       |          |       |       |         |       |       |
| Selection of buffer relay  | <p>(1) Coil rating ... Less than the contact rating of output terminals<br/>(2) Contact rating ... More than twice the load current</p> <p>A coil surge absorption element built-in type relay is recommendable. Mount an additional buffer relay if a buffer relay satisfying the load rating is not available.</p>   |                |                                |                |                                |          |       |       |          |       |       |         |       |       |
| Selection of contact protective element  | <p>Mount a contact protective element if a surge absorption element built-in buffer relay is not available. This element is generally composed of C (capacitor) and R (resistor).</p> <p>&lt;Reference value of C·R&gt;<br/>C:0.01μF (Rating around 1KV)<br/>R:100 to 150Ω (Rating around 1W)</p>  |                |                                |                |                                |          |       |       |          |       |       |         |       |       |

## 5.6 Connection of digital input terminals and function selection (option)

This is for the recorder with alarm output terminals (option)

### 1) Digital input terminal

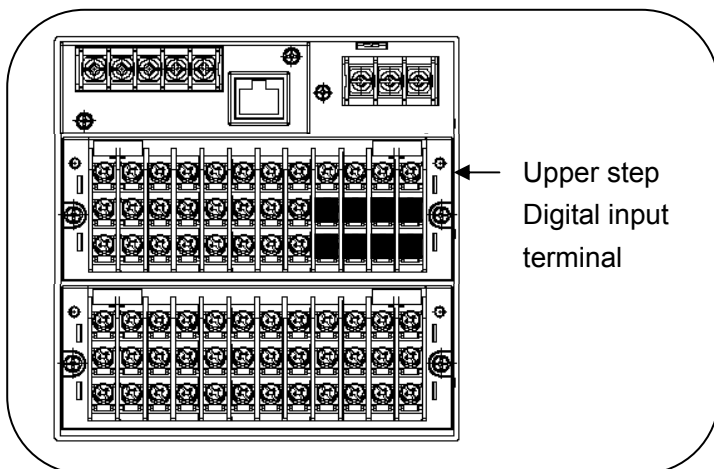

#### Notes Features of digital input terminal

- Voltage when the contact is open :  
Approximately 5 V
- Current when contact short :  
Approximately 2 mA

### 2) Connections

Turn off the power supply before connections to prevent an electric shock.

- (1) Apply a no-voltage contact signal to digital input terminals.
- (2) Use cables terminated by crimp style terminals with insulation sleeves for the digital input terminals.

#### **⚠ Caution**

##### ■ No voltage contact input

For the contact to be connected to the Digital input terminal, use a switch or relay driven at lower than 30 V AC or lower than 60 V DC, or manual contacts for very light loads.

#### ■ Connection example

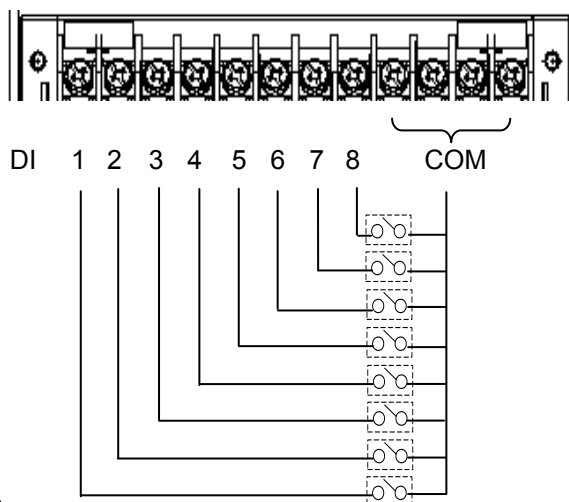

##### ■ Function of the terminals

- (1) Digital input      ON/OFF (short/open) state can be measured. Select the range type as DI.  
(Refer to Para.13.2 Input operation settings.)
- (2) Pulse input      Used as the pulse input. Select the range type as Pulse (+) and Pulse (-).  
(Refer to Para.13.2 Input operation settings.)
- (3) Totalizer reset    The reset of totalizer is executed. When the digital input terminal specified becomes ON, the totalizer reset is executed.  
(Refer to Para.13.6 Totalizer reset settings.)
- (4) Marker            The writing of marker. The marker can be written on the trends when the digital input terminals become ON.  
(Refer to Para. 13.8 Marker text settings.)
- (5) File drive        The recording start/stop of data file in the internal memory is executed. The recording starts or stops when the digital input terminals become ON or OFF.  
(Refer to Para. 13.5 File settings.)

## 5.7 Connection of communication I/F terminal (partly option)

The KR2000 can be communicated with a master unit via Ethernet and RS232C or RS485, and with a slave unit via RS485.

\*RS-485/232C terminal and serial communication function are optional.

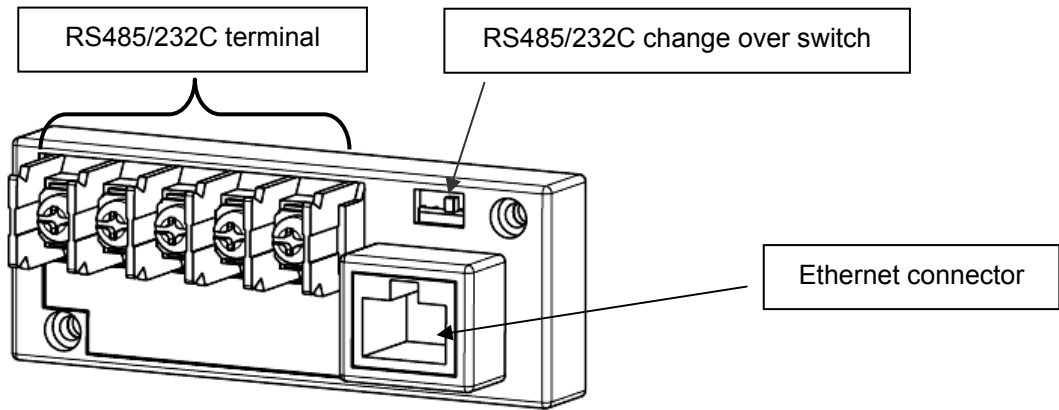

### 1) In case of high order communications via Ethernet

#### [In case of connection with a PC by 1 to 1]

For the connection of a PC and the Ethernet IF by 1 to 1, use the STP crossover cable.

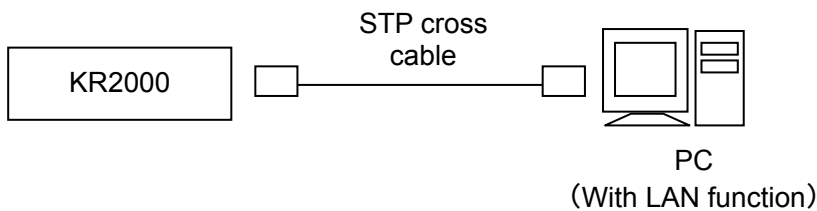

#### [In case of connections with PCs by N to N]

For the connection to multiple PCs or an existing LAN, use a switching hub and an STP straight cable between the hub and the Ethernet IF.

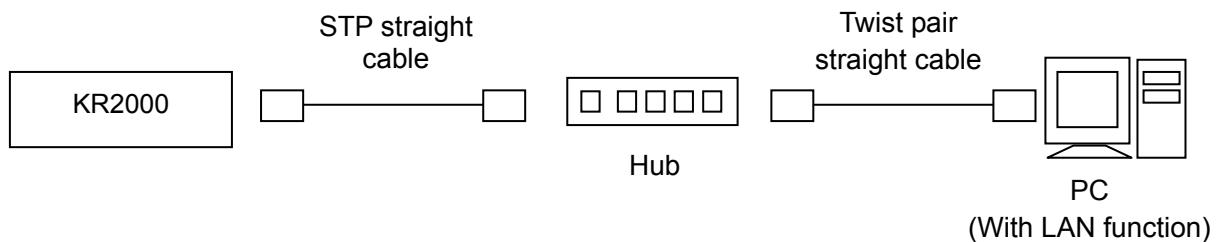

### 2) Kind of communication terminal (option)

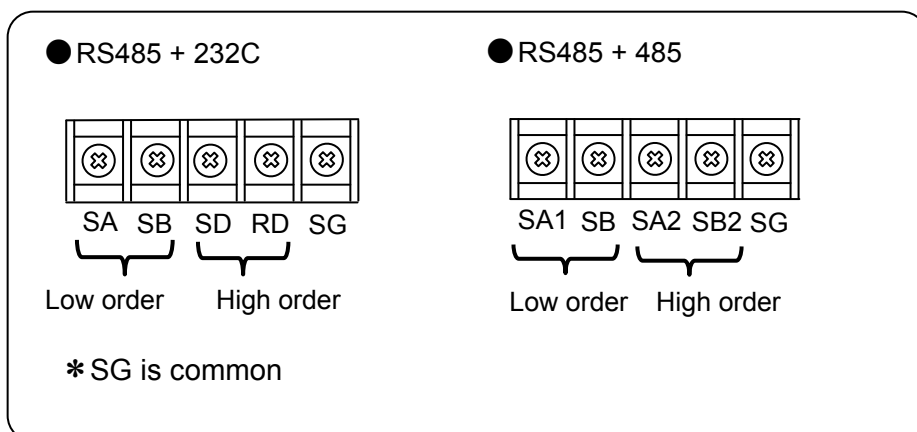

### 3) Connection of High order communication RS-232C

The communication terminals of this recorder are three terminals of SD, RD and SG and a control signal is not used. General personal computers use the control signal. Wiring processing for control signal in a connector depends upon how the control signal is used in a personal computer. For details, refer to the instruction manual for your personal computer.

#### (1) Example of 9 pin connector

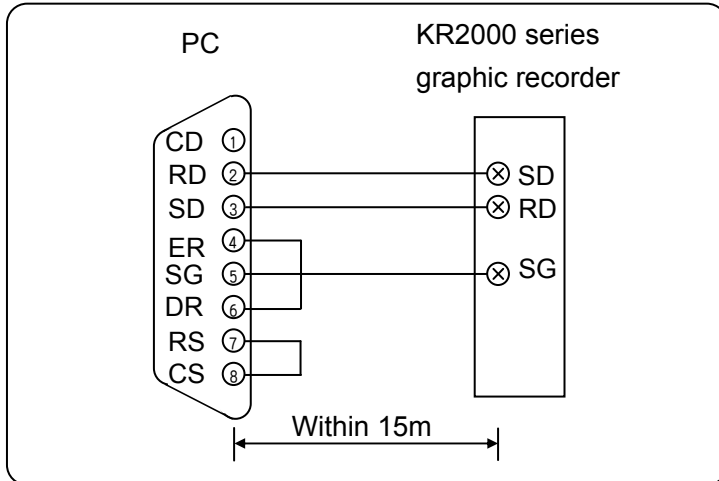

#### (2) Example of 25 pin connector

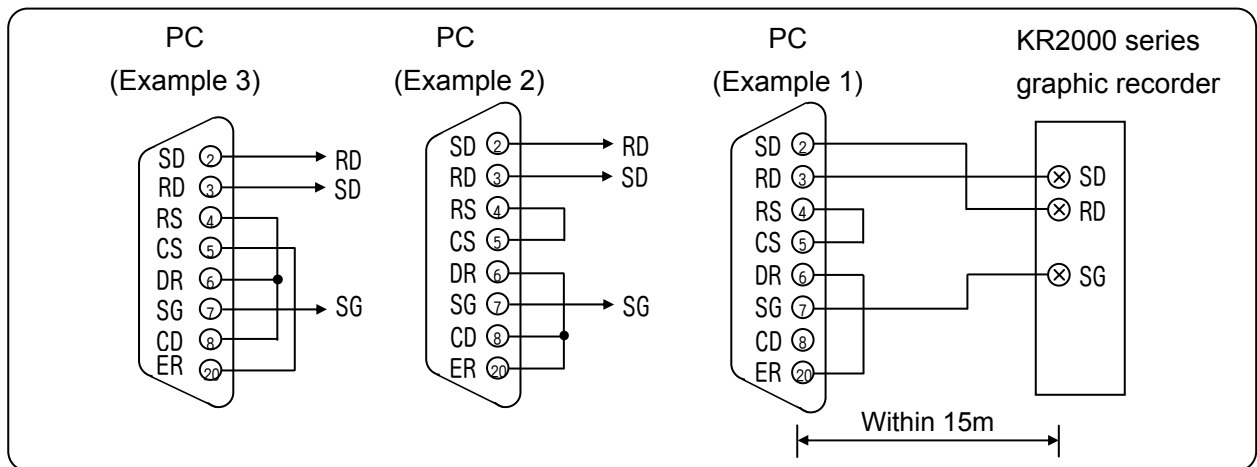

#### 4) Connection of High order communication RS-485

The RS-485 communications interface is connected to a personal computer via a protocol converter (our Model SC8-10: sold separately). Three signals of SD, RD and SG are used between the protocol converter and a personal computer and a control signal is not used. Wiring process of connector similar to “(3) High order communication RS-232” on the previous page, is necessary.

#### Notes Mounting termination resistor

To ensure the transmission of data via RS-232C or RS-485 communications, mount a termination resistor at both ends of transmission lines. When the protocol converter (SC-8) is at an end of a transmission circuit, short the terminals of ④ and ⑤ of the unit to insert the termination resistor automatically.

#### High order communication for RS485

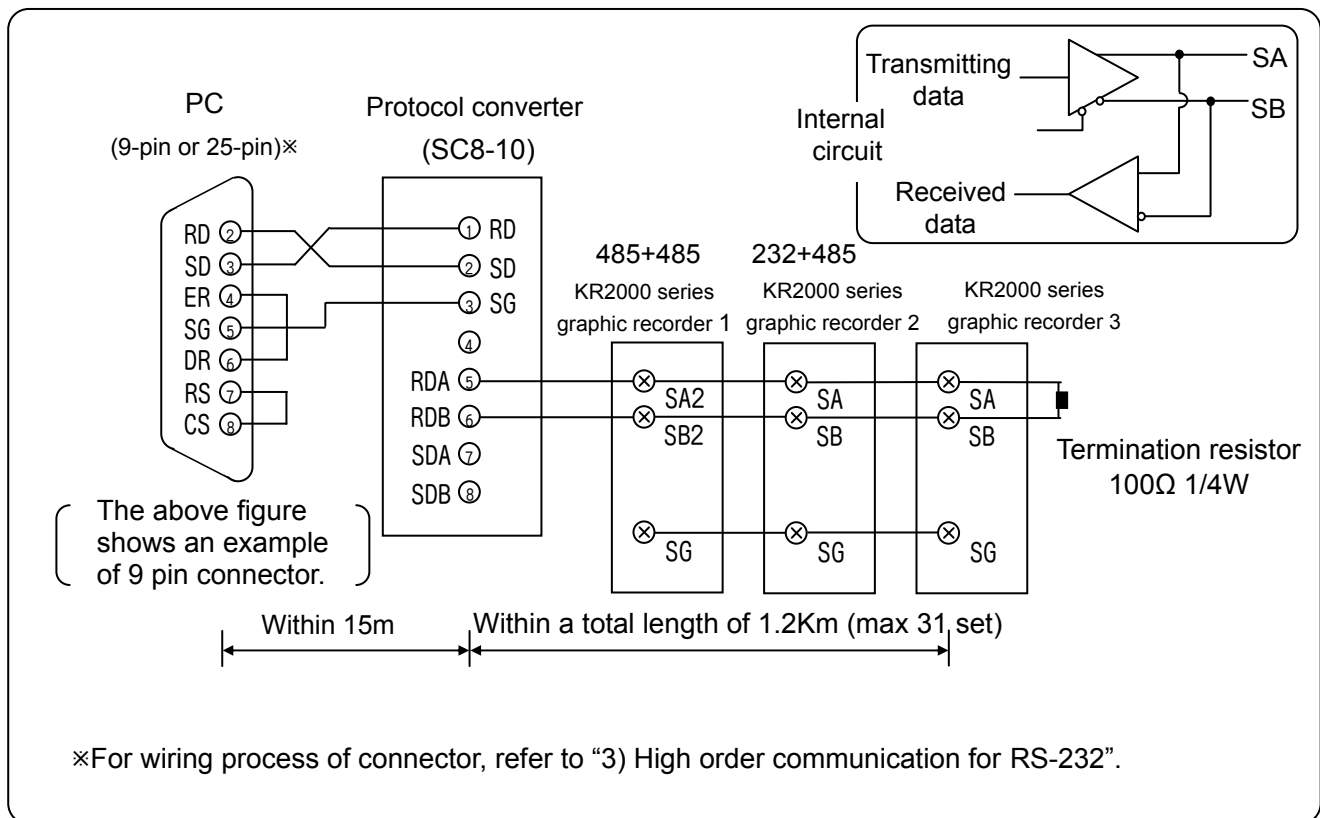

### 5) Connection of Low order communication RS-485

Connect SA1, SB1 of KR2000 and SA, SB of low order connected instrument like the following figure. Refer to instruction manual of each instrument for detail method of low order instrument connection.

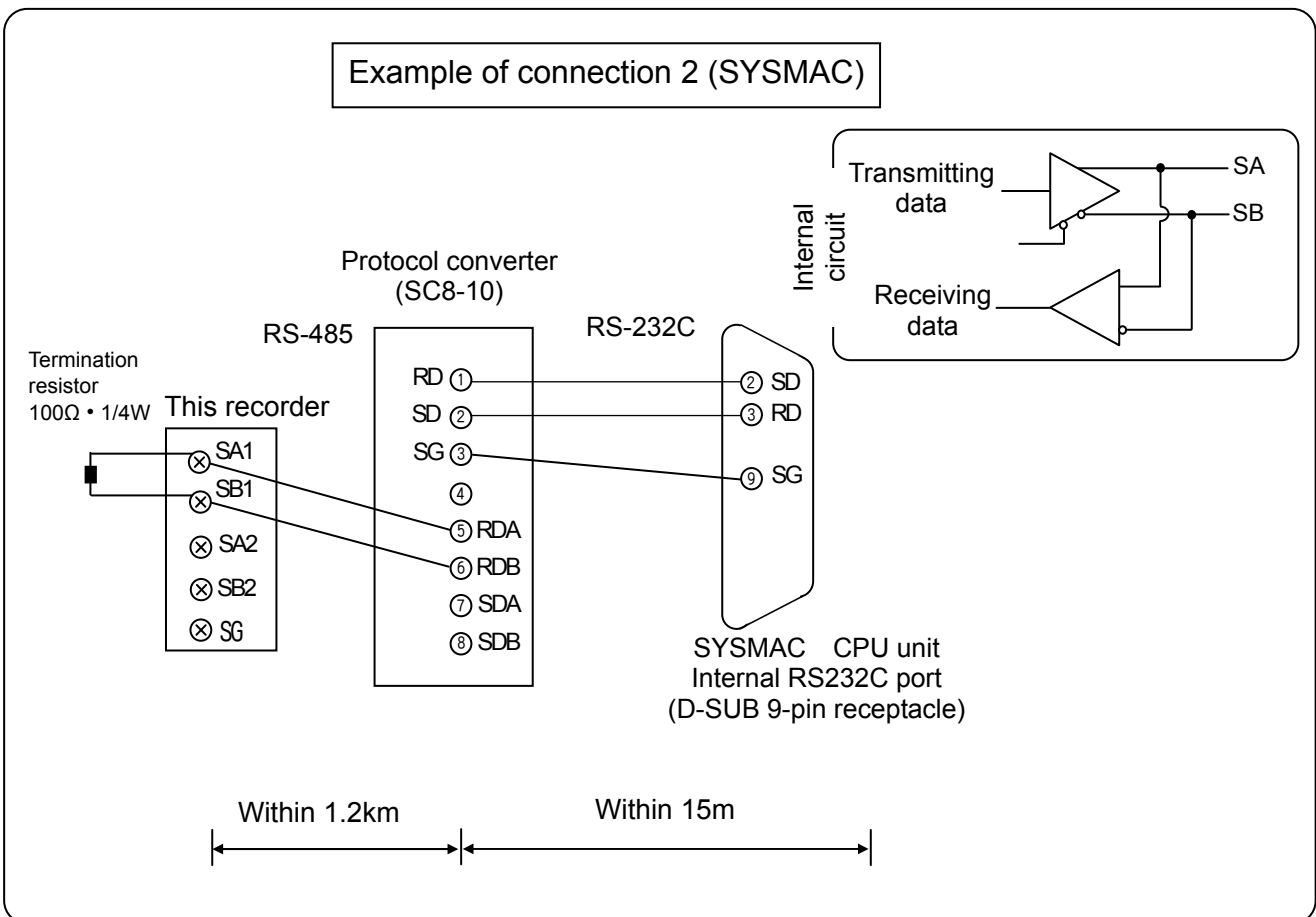
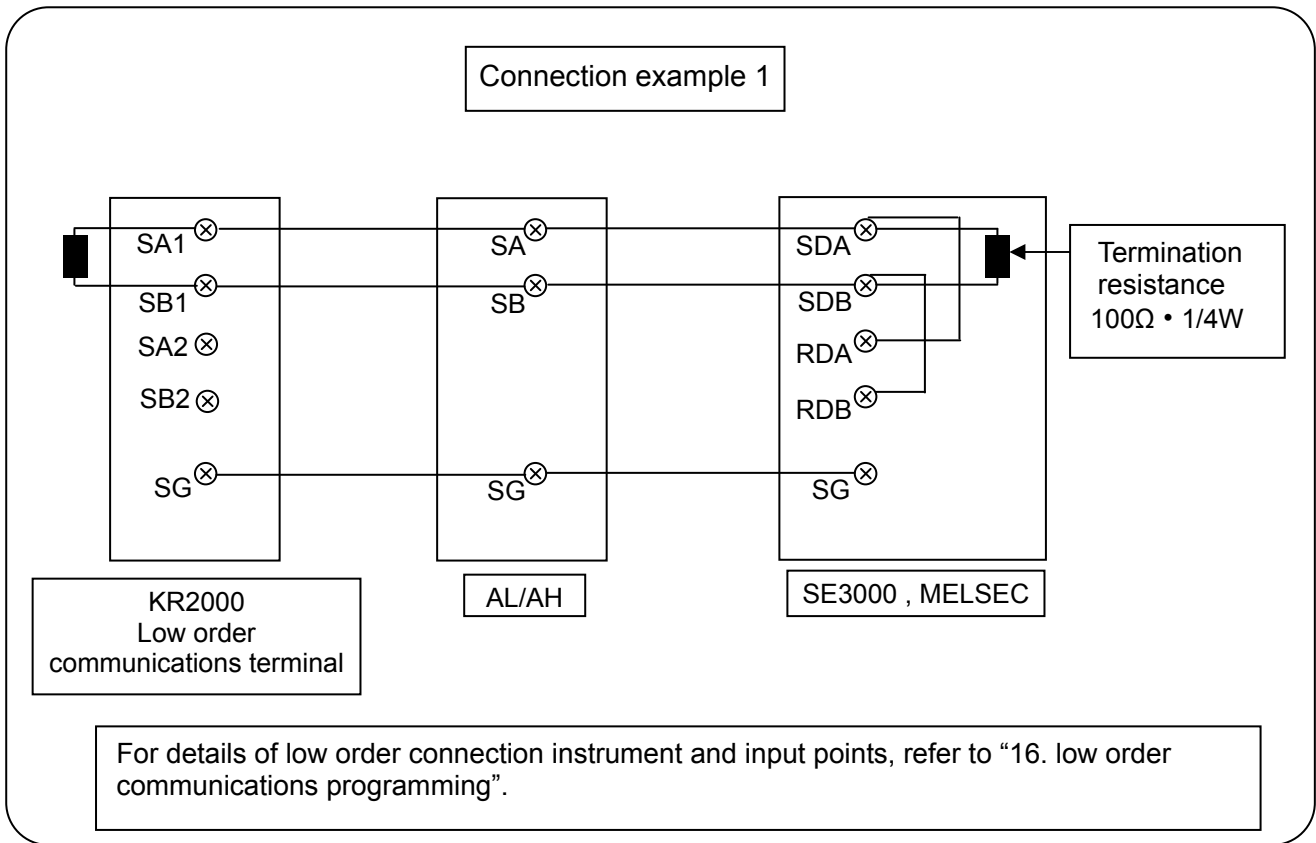

# 6 Operation (Be sure to read section 1 to ensure safety.)

Default setting values have been set at the factory. For actual operation, be sure to execute the following settings.

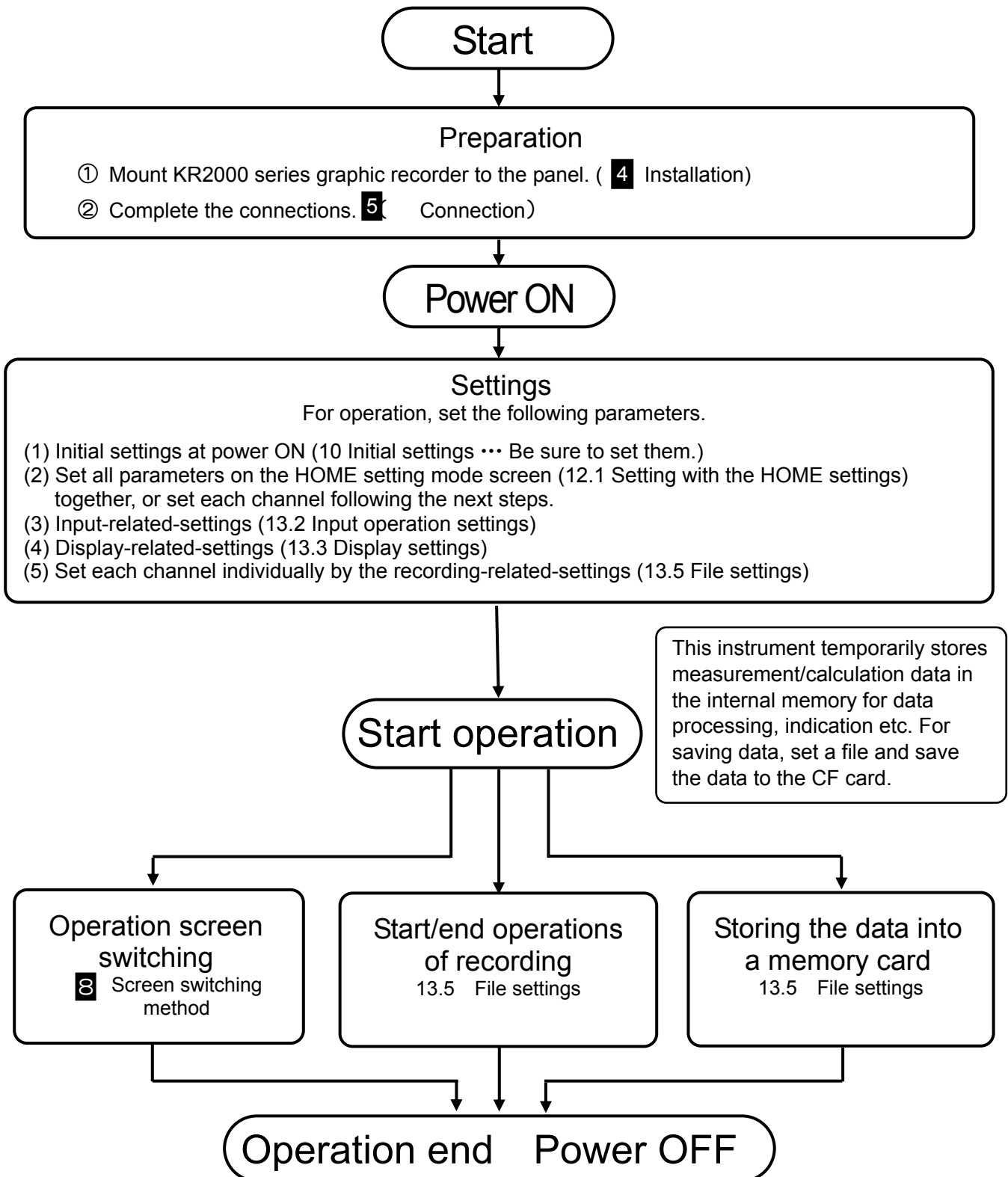

● On part of the LCD screen, some pixels may always be lit or not lit, and unevenness in brightness may arise from the characteristic of the liquid crystal, but these are not malfunctions.

# 7 Name of each part

## 7.1 Name of the front panel and its major functions

Display

5.6 inch TFT color LCD  
Operation screen: Refer to 9

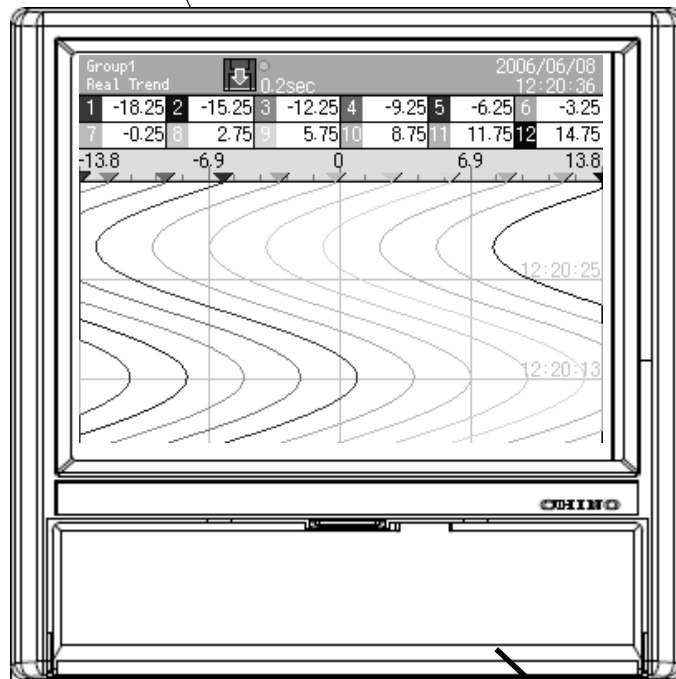

Key cover raised

Key cover

USB port

File on the CF card can be accessed by connecting to the PC.

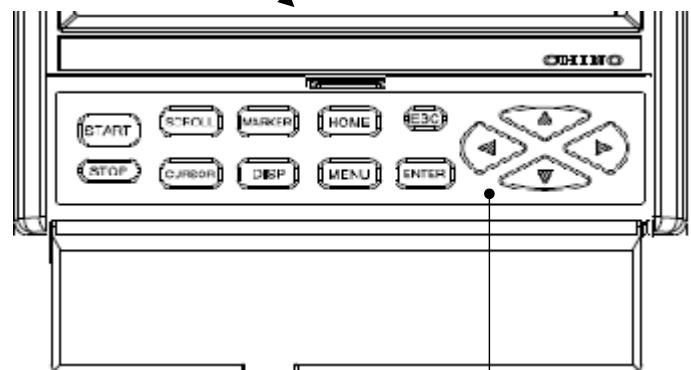

Key case raised

Keyboard

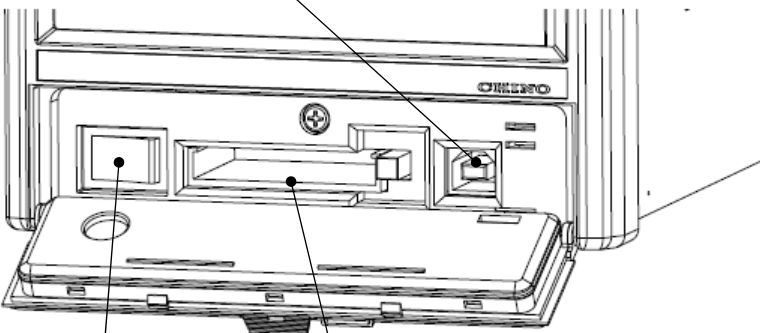

Power switch

CF card drive











**Caution**

■ Front glass  
The front of display part is made by glass. To avoid injuries due to broken glass, do not blow the glass hard.

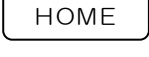

## 7.2 Name of keys and their functions

Usage and functions of keys differ depending on the operation screen and the setting screen .

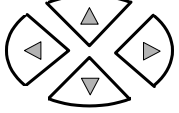
| Key   | Key of each screen and their major functions and methods of using               |   |
|---|---|---|
|   | Operation screen  | Setting screen  |
|                      | The recording starts  | Not used  |
|                      | The recording stops   | Not used  |
|                      | Used for switching of the scroll mode and for moving to historical trend screen | Not used  |
|                      | Used for switching the cursor mode in the historical trend screen               | Not used  |
|                      | Used to write a marker on the trend screen.                                     | Not used  |
|                    | Used to display the DISP menu.  | A snapshot is taken by pressing this key for a long time.   |
|                    | Used to display the HOME setting menu.  | Used to quit the Home screen.   |
|                    | Used to display the MENU setting menu   | Used to return a previous screen  |
|                    | Used for canceling menus or for returning to a previous screen                  | Used to return from the setting screen to the operation screen or return to a previous screen.  |
|                    | Used to enter a menu item or display the ENTER menu.                            | Used to open a selected menu or enter a numeric value, a character, etc. selected by the cursor. Also, used to store a parameter when the setting screen returns to the operation screen. |
| <br>Direction keys | Use to select a menu item or change a display group and a channel.              | Used to move the cursor to the left, right, up and down   |

### 7.3 Method of inputting the characters

This screen is used for setting a tag name, a marker text character string and setting/entering a password.

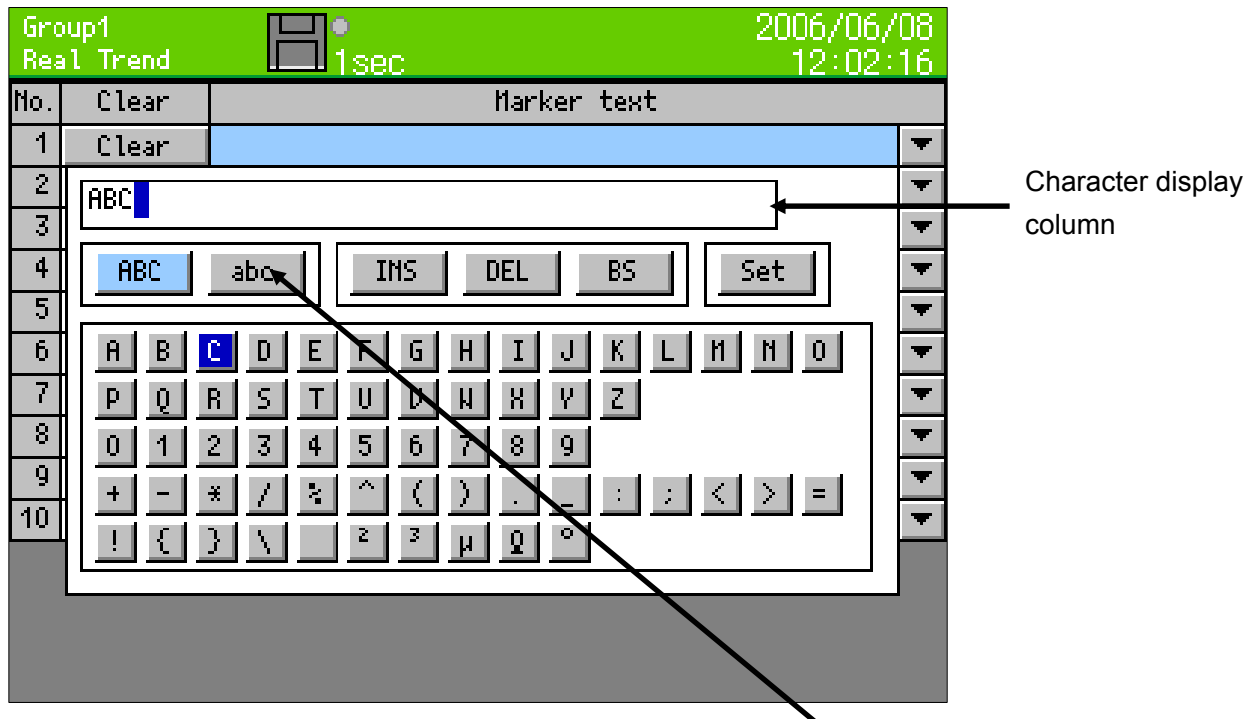

By taking the focus (blue) to upper case English characters, lower case English characters and Kana, the input character list underneath, changes.

When character input screen is displayed, if down key of the direction key is clicked, after taking the focus (blue) to upper case English characters and kana etc. the focus moves to the below column. When the focus (blue) moves to the below column, move the focus using the arrow key up to the character to be entered and then click the ENTER key. Selected character is displayed in the character display column.

- ABC** Alphabet capital letters, symbols and numeric can be entered.
- abc** Alphabet small letters, symbols and numeric can be entered.
- INS** Insert or overwrite can be selected.  
(Inserting and overwriting are switched each time this key is pressed.)
- DEL** A character selected on the character input column is deleted.
- BS** The character being one position before the character selected on the character input column, is deleted.
- Set** Inputted characters are entered. Inputted characters are also entered by pressing the ENTER key after moving the focus to the character input column.

MEMO

# 8 Screen switching method

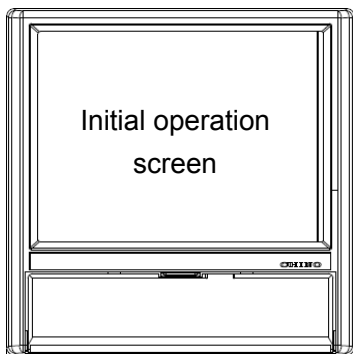

When the power is turned on, the operation screen is displayed after performing the initial operation for about 10 seconds. (Default settings at the factory: Real time trend screen). When the power is turned on after changing the operation screen, the “operation screen that was selected when the power was turned off” is displayed.

Approximately  
10 seconds

Switching to the setting screen  
When the key shown in the right is pressed on the operation screen, the screen is switched to the setting screen for setting each parameter.

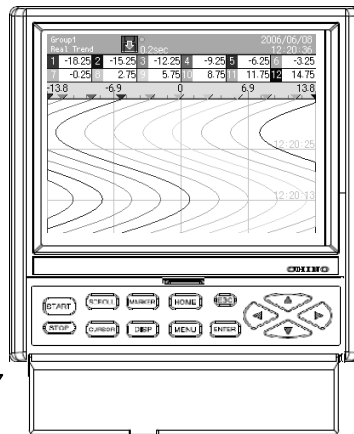
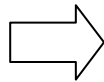
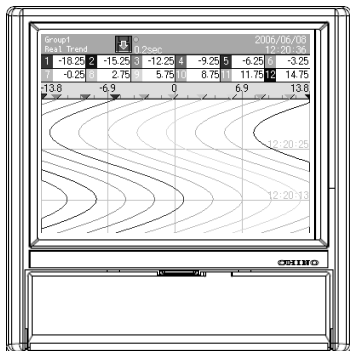

HOME

MENU

Open the key cover

## Operation screen switching method

The operation screen switching is executed by selecting the DISP menu. Switch to a desired screen with the following procedures.

(1) Press the [DISP] key to display the DISP menu.

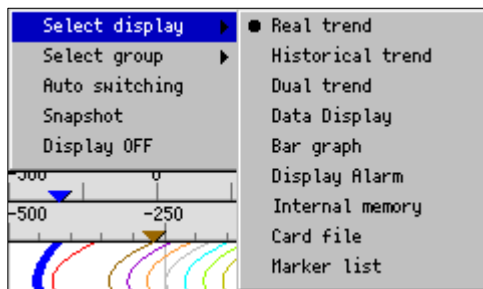

(2) Select a menu with the direction key and press the [ENTER] key to display a screen selected.

- Display selection: For selecting the display type (Real time trend, numeric display, etc.) of the screen
- Group selection: For selecting the group to be displayed.

\* When the [Auto switching] is selected (with checking), the display group is automatically switched at a fixed interval.

<HOME settings>

The settings are used to execute same settings to all channels easily. The items settable are limited. The settings cannot be used during recording.

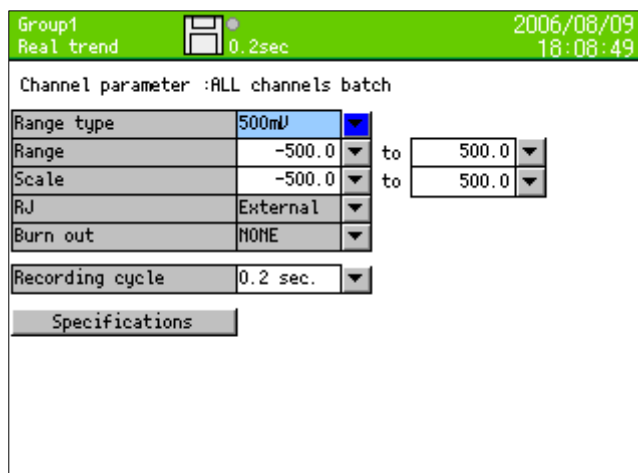

<MENU settings>

The settings are used for normal settings. All items can be set and seen during recording, but there are some items not settable. The items not settable are displayed in gray.

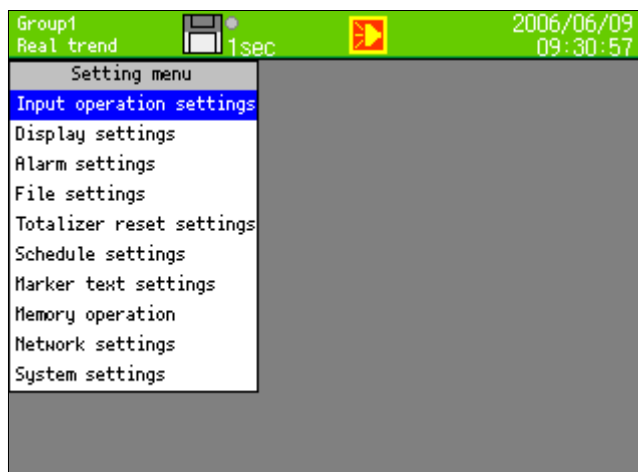

# 9 Name and functions of operation screen

## 9.1 Common operations of operation screen

(Using method of each key)

START

The recording is started. The data of the groups, of which recording conditions are established, are stored into the internal memory. The groups, of which recording conditions are not established, become the standby state and their recording starts at the time of establishment of conditions. The groups, of which recording conditions cannot be established, become the standby state for recording. The storing into the CF card is automatically executed at certain storing intervals when the saving to a file is completed.

STOP

The recording is stopped. The recording of all groups becomes the stop state. The file in saving is completed and data is stored into the CF card.

DISP

The DISP menu is displayed.

| Menu item      | Operation  |
|----------------|--|
| Select display | Used to change the operation screen type.  |
| Select group   | Used to change the display group.  |
| Auto switching | Used to turn or off the automatic switching of the group and channel. The switching becomes active by checking. When the automatic switching time is set to 0, this switching is not valid.              |
| Snapshot       | Used to save a hard copy of a screen to the CF card (SNAPSHOT folder).   |
| Pause          | Screen updates are stopped except status bar. When press any key, the screen is displayed again. All operations except describing of data recording and recording processing are performed during pause. |
| Display OFF    | Used to turn off LCD display. The LCD is turned on again by pressing any of buttons.   |

HOME

MENU

Each setting screen is displayed. (Refer to chapter 7.2)

ENTER

The ENTER menu is displayed. Menu contents differ depending on the screens.

ESC

The screen is returned to a previous screen. In case of the screens of the real time trend, the bar graph and the numerical display, the screens do not return to a previous screen.

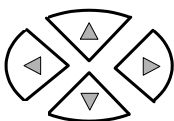

For the vertical trend,

The display group is switched with the up and down keys and the displayed channel is switched with the left and right keys.

For the horizontal trend,

The display group is switched with the left and right keys and the displayed channel is switched with the up and down keys.

(Displayed data)

Measured data displayed on each screen

| Measured data   | Contents   |
|-----------------|--|
| (Numeric value) | The values are displayed based on the display scale settings of each channel. The values are displayed with the number of digits after decimal point of the maximum and minimum values of the display scale..<br>When the type is "Exponent", the values are displayed in such exponential format as "1.2E+3". In this case, up to 2 digits after the decimal point of the significand can be set but only 1 digit is displayed depending on the screen. |
| BURN            | Open between terminals   |
| OVER            | A value above the measurable high limit value (upper limit value + 5% of range) is inputted.<br>Or calculated value is above the value that can be indicated (*).  |
| UNDER           | A value below the measurable low limit value (lower limit value - 5% of range) is inputted.<br>Or calculated value is below the value that can be indicated (*).   |
| CAL ER          | Calculation error  |
| RJ ERR          | The recorder is abnormal   |

\* Range that can be indicated for calculated result as follows.

Display format is "standard"

Numeric value that exclude decimal point is within  $\pm 30000$  (Example: -30.000 to +30.000)

Display format is "index"

1.00E-15 to 9.99E+15

Excluding the historical data displayed part of the historical trends and the dual trends, the current data (with 0.1 seconds interval) irrespective of the recording interval, etc. is displayed as the numeric displayed data. For slowing down the updating speed, change "Numeric value display update interval". (Refer to Para. 13.3.3.)

## 9.2 Status bar

The status bar is displayed on the top of the screen and displays the status, etc. of this recorder. Normally the back color is green but, when the schedule (Refer to Para. 13.7) is set, the back color becomes gray for the period other than the scheduled period.

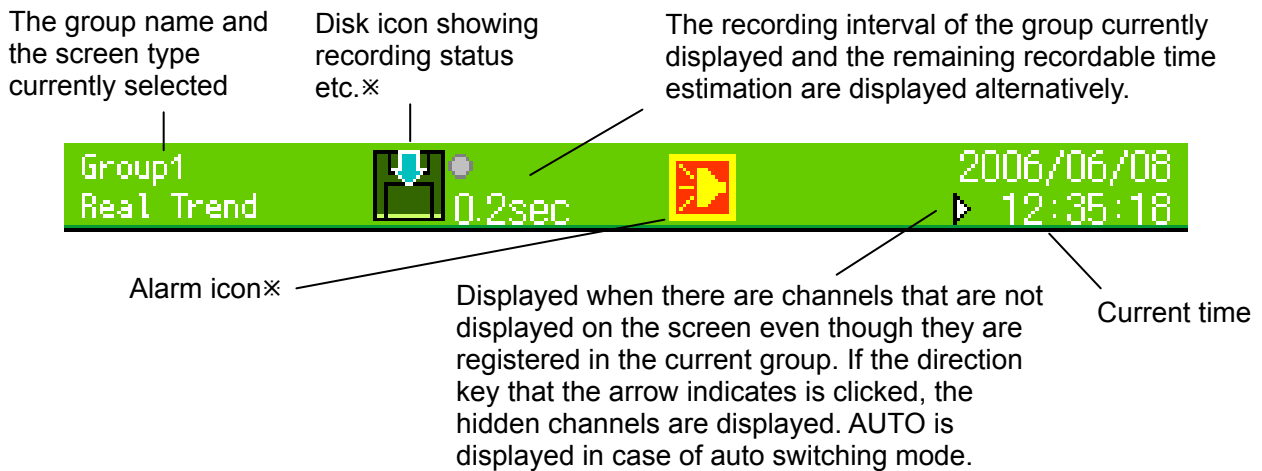

### Disk icon

Back color displays recording status of the group that is currently displayed.

| Back color     | Status  |
|----------------|---|
| Green          | Recording. The arrow moves.   |
| Green blinking | The START key was pressed but the recording is in the standby state since recording conditions are not established. |
| Gray           | The START key is not pressed. (In the state that the recording is stopped by pressing the STOP key)                 |
| Yellow         | The remaining space of the CF card is less than 10%.  |
| Red            | The CF card has no space.   |

When X is displayed on the disk mark, the CF card is not inserted.



The circle on the upper right of the icon shows the access status to the CF card. If the CF card is removed when the color is red, data may be damaged. Remove the CF card when the circle is gray.

| Color  | Status   |
|--------|--|
| Gray   | Not accessing to the CF card.                                      |
| Yellow | Writing in the CF card is executed within approximately 5 seconds. |
| Red    | Accessing to the CF card   |

### Alarm icon

The icon shows the activation status and the confirmation status of alarms. The confirmation (ACK) of alarm is executed with the ENTER menu on the operation screen.

| Icon status          | Alarm status                    | Confirmation (ACK) status |
|----------------------|---------------------------------|---------------------------|
| Lit                  | Activated                       | Confirmed                 |
| Icon inside blinking | Activated                       | Not confirmed yet         |
| Icon blinking        | After released                  | Not confirmed yet         |
| Not displayed        | After released or not activated | —                         |



### 9.3 Real time trend screen

The trends of measured values can be seen like an analog recorder. The pens are displayed on the scale plates corresponding to the values of “Display position” parameters of each channel. When the same “Display position” is set to multiple channels, the scale plates, trends and pens are displayed in the contents of the display scale of the smallest channel number in the group.

The measurement data of the alarm activated is displayed in red

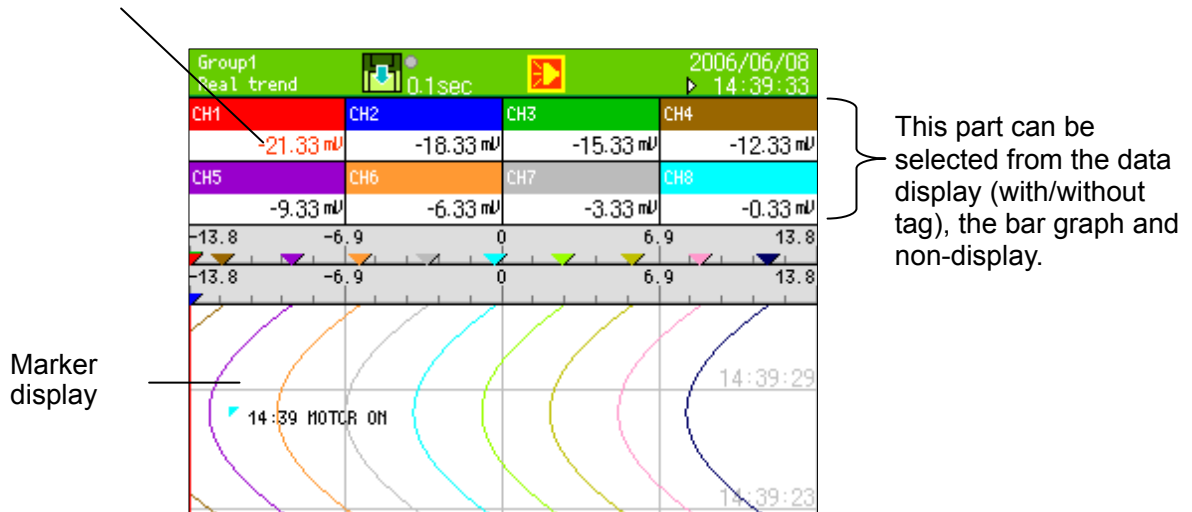

ENTER menu function

|                       |   |
|-----------------------|---|
| Expansion/compression | The trends are displayed by compressing the time axis. (Same magnification to 1/64) |
|-----------------------|---|

Key operations other than the common operations (Para. 9.1)

SCROLL

The historical trend (or the dual trend) screen is displayed. This key operation is same as selecting the historical trend (or the dual trend) in the DISP menu. When the historical trend is selected in the DISP menu, the trends are displayed from then and, when the dual trend is selected, the trends are displayed from then.

MARKER

The marker-write dialog box is displayed. The marker writing cannot be executed during the record stop. Select a marker text registered with the MENU settings beforehand and write the text on the trends by pressing the ENTER key. When the “Input Text” is selected, the keyboard screen is displayed for writing a text desired.

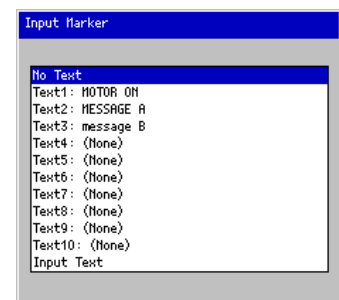

## 9.4 Bar graph screen

The measured values of the channels are displayed with the bar graphs in real time and can be seen visually. The length of the bars and scale plates is displayed in the contents of the display scale with the smallest channel number in the group.

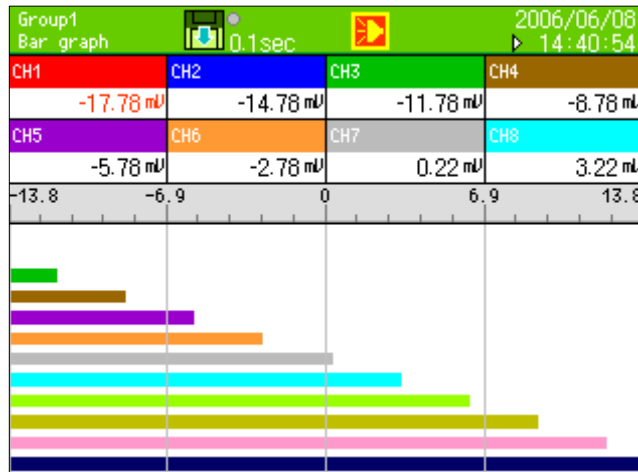

This part can be selected from the data4 display (with/without tag) and non-display.

ENTER menu function

Not available

Key operations other than the common operations (Para. 9.1)

Not available

## 9.5 Numeric display screen

The “Measured data of channels” and the “Alarm activation status” are displayed. Depending on the “Number of numeric value display frames” or the number of groups registered, data of 1, 4, 6, 12, 21 or 44 channels are displayed.

The measured data of the channel in alarm activated is displayed in red.

| Channel | Value (mJ) |
|---------|------------|
| CH1     | -21.17     |
| CH2     | -18.17     |
| CH3     | -15.17     |
| CH4     | -12.17     |
| CH5     | -9.17      |
| CH6     | -6.17      |
| CH7     | -3.17      |
| CH8     | -0.17      |
| CH9     | 2.83       |
| CH10    | 5.83       |
| CH11    | 8.83       |
| CH12    | 11.83      |

## 9.6 Historical trend screen

The recorded data are replayed and displayed as the trend display. When the “Historical trend” is selected in the DISP menu (or when the “SCROLL” key on the real trend screen is pressed), data in the internal memory are displayed. When a file is selected in the “Card file” screen, data of the selected file are displayed. The historical trend operation method is the same for each selection. The display method of the scale plates, trends and pens is same as the real time trend screen.

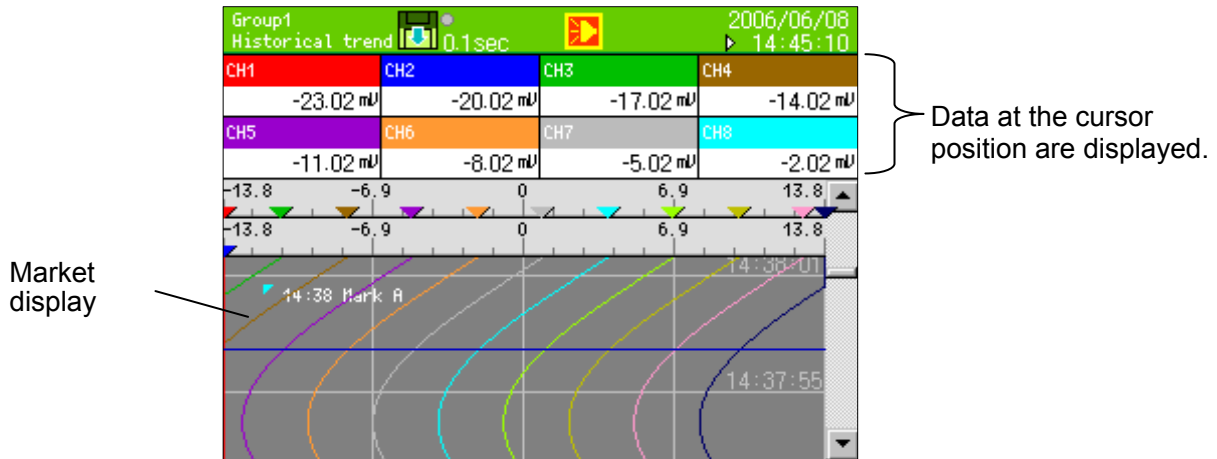

### ENTER menu function

|                       |   |
|-----------------------|---|
| Expansion/compression | The trends are displayed by compressing the time axis. (Same magnification to 1/64) |
|-----------------------|---|

### Key operations other than the common operations (Para. 9.1)

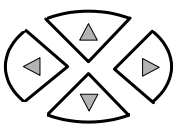

For vertical trend

Left and right keys: Switching the displayed channel

Up and down keys: Scrolling the trend graph and moving the cursor when the cursor mode is ON

For horizontal trend

Left and right keys: Switching the displayed channel

Up and down keys: Scrolling the trend graph and moving the cursor when the cursor mode is ON

SCROLL

Press this key to switch to the scroll mode. When this key is pressed once, the scroll bar is enclosed with a yellow frame and the scroll mode becomes ON. In this status, by pressing the direction key, the trends are scrolled one screen by one screen. When the scroll key is pressed again, the scroll mode becomes OFF and the trends are scrolled one dot by one dot by pressing the direction key.

CURSOR

Press this key to switch to the cursor mode. When this key is pressed once, the cursor line is displayed in yellow color and the cursor mode becomes OFF. In this status, by pressing the direction key, the cursor line moves without scrolling and the data at the cursor position are displayed on the numeric value display (or bar).

MARKER

The marker-write dialog box is displayed. Select a marker text registered with the MENU settings beforehand and write the text at the cursor position by pressing the ENTER key. When the “Input Text” is selected, the keyboard screen is displayed for writing a text desired.

HOME

When the “data format” of the file to be displayed is “Maximum/Minimum”, the values displayed in the numeric value display (or bar) are switched to the maximum and minimum values. Other operations are same as the HOME key. Either of the current display is shown in H or L display on the status bar.

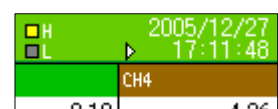
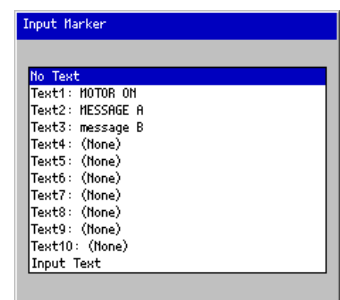

## 9.7 Dual trend screen

The real time trends and the historical trends are displayed by dividing the screen up and down, and the current data and the past data can be compared. Also the data display displays the current values and values at the cursor position of the historical trends by dividing the screen up and down. The displaying method of the trends and positions of pens is same as the real time trend screen. However, in case of the setting that multiple scale plates are displayed, only 1 scale plate is displayed, and the numeric values on the scale plate are not displayed. The operation method is the same as the historical trend screen.

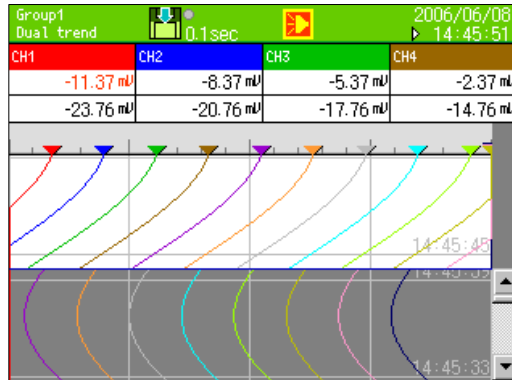

Up: Current measured values  
Down: Display of data at the cursor position on the historical trends

ENTER menu function

|                       |   |
|-----------------------|---|
| Expansion/compression | The trends are displayed by compressing the time axis. (Same magnification to 1/64) |
|-----------------------|---|

Key operations other than the common operations (Para. 9.1)  
Same as historical trends. (Refer to Para. 9.6)

## 9.8 Alarm display screen

The alarms being activated are displayed as a list. Activation date/time, cancel date/time (cancelled alarms only), channels (tag names) and alarm types are displayed in the reverse chronological order (latest on the top). Irrespective of the groups, all alarms being activated in this recorder are displayed. Maximum 1000 alarm data are recorded. When the alarm data exceeds 1000, the data are deleted in chronological order.

The selected row is displayed in yellow

| Activation time | Cancel time    | CH  | Type       |
|-----------------|----------------|-----|------------|
| 05/30 18:58:23  |                | CH1 | AL1 D. upp |
| 05/30 18:57:43  | 06/08 13:41:47 | CH2 | AL4 Upper  |
| 05/30 18:57:43  | 06/08 13:41:47 | CH2 | AL3 Upper  |
| 05/30 18:57:43  | 06/08 13:41:47 | CH2 | AL2 Upper  |
| 05/30 18:57:43  | 06/08 13:41:47 | CH2 | AL1 Upper  |
| 05/30 18:57:43  | 05/30 18:58:17 | CH1 | AL4 Upper  |
| 05/30 18:57:43  | 05/30 18:58:17 | CH1 | AL3 Upper  |
| 05/30 18:57:43  | 05/30 18:58:17 | CH1 | AL2 Upper  |
| 05/30 18:57:43  | 05/30 18:58:17 | CH1 | AL1 Upper  |
| 05/30 18:57:13  | 05/30 18:57:24 | CH1 | AL4 Upper  |
| 05/30 18:57:13  | 05/30 18:57:24 | CH1 | AL3 Upper  |
| 05/30 18:57:13  | 05/30 18:57:24 | CH1 | AL2 Upper  |
| 05/30 18:57:13  | 05/30 18:57:24 | CH1 | AL1 Upper  |
| 05/30 18:56:56  | 05/30 18:57:03 | CH1 | AL1 Upper  |
| 05/30 18:56:21  | 05/30 18:56:50 | CH1 | AL1 Upper  |
| 05/30 18:56:07  | 05/30 18:56:14 | CH1 | AL1 Upper  |

ENTER menu function

|               |   |
|---------------|---|
| Trend display | The screen is jumped to the trend at the activated date/time of the selected row. When the alarm was not recorded at its activation or the file is not found, the screen cannot be jumped.<br>The file search in this case is executed in the order of the internal memory → the CF card. |
|---------------|---|

Key operations other than the common operations (Para. 9.1)

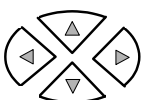

Up and down key: Moving the row for selection  
Left and right key: Not used



Press this key to switch to the scroll mode. When this key is pressed once, the scroll bar is enclosed with a yellow frame and the scroll mode becomes ON. In this status, by pressing the direction key, the trends are scrolled one screen by one screen. When the scroll key is pressed again, the scroll mode becomes OFF and the trends are scrolled one line by one line by pressing the direction key.

## 9.9 Internal memory screen

The list of files recorded in the internal memory is displayed. The start date and time, the end date and time (the latest data time for a file being recorded) and the data count are displayed. The files are displayed in the reverse chronological order (latest on the top). All files only of the selected group are displayed.

The selected row is displayed in yellow

| Start date and time | End date and time   | Data count |
|---------------------|---------------------|------------|
| 2006/06/08 16:40:30 | 2006/06/08 16:49:35 | 5455       |
| 2006/06/08 16:31:30 | 2006/06/08 16:32:26 | 569        |
| 2006/06/08 16:24:35 | 2006/06/08 16:24:42 | 74         |
| 2006/06/08 16:19:11 | 2006/06/08 16:19:27 | 161        |
| 2006/06/08 16:15:59 | 2006/06/08 16:16:36 | 373        |
| 2006/06/08 14:44:27 | 2006/06/08 14:49:18 | 2916       |
| 2006/06/08 14:35:41 | 2006/06/08 14:43:13 | 4522       |
| 2006/06/08 13:42:17 | 2006/06/08 13:42:48 | 315        |
| 2006/06/08 13:41:49 | 2006/06/08 13:42:03 | 141        |
| 2006/06/08 13:41:24 | 2006/06/08 13:41:32 | 84         |
| 2006/06/08 13:41:15 | 2006/06/08 13:41:15 | 2          |
| 2006/06/08 13:41:13 | 2006/06/08 13:41:13 | 10         |
| 2006/06/08 13:41:11 | 2006/06/08 13:41:11 | 10         |
| 2006/06/08 13:41:09 | 2006/06/08 13:41:09 | 10         |
| 2006/06/08 13:41:07 | 2006/06/08 13:41:07 | 10         |
| 2006/06/08 13:41:05 | 2006/06/08 13:41:05 | 10         |
| 2006/06/08 11:50:07 | 2006/06/08 11:51:54 | 1070       |

### ENTER menu function

|               |  |
|---------------|--|
| Trend display | The trends recorded in the file of the selected row are displayed. |
|---------------|--|

Key operations other than the common operations (Para. 9.1)

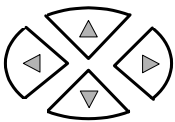

Up and down key: Moving the row for selection  
Left and right key: Not used



Press this key to switch to the scroll mode. When this key is pressed once, the scroll bar is enclosed with a yellow frame and the scroll mode becomes ON. In this status, by pressing the direction key, the trends are scrolled one screen by one screen. When the scroll key is pressed again, the scroll mode becomes OFF and the trends are scrolled one line by one line by pressing the direction key.

## Internal memory

This recorder records all recorded data into the internal memory as a file. The data are copied to the CF card at a certain storing interval when the recording to this file is completed

<Limitations of internal memory>

(File capacity)

1 file is completed with maximum volume (refer to the following list). The file size can be calculated with the followings.

Data volume x Number of channels x Number of records

(Usually the data volume is 4 bytes. When the data format is "Maximum/minimum", the data volume is 6 bytes.)

When the recording is stopped due to recording conditions not established, by pressing the STOP key or by power off, etc. the file is completed at the time before reaching to maximum volume of file.

| Number of groups used | Maximum volume of file (KB) | Recording frequency when 12 points are used (4 byte data) |
|-----------------------|-----------------------------|---|
| 1                     | 1920                        | 40960   |
| 2                     | 896                         | 19110   |
| 3                     | 576                         | 12280   |
| 4                     | 384                         | 8190  |
| 5                     | 320                         | 6820  |

(Number of files)

The number of files that can be saved in the internal memory is maximum 250 files (In each group, "250 ÷ Number of groups used" [Fraction is rounded down.]).

(Volume of all files)

The total volume of files that can be saved in the internal memory is 64KB x (63 ÷ (Number of groups used) – 2). If the volume exceeds it, the files are deleted in chronological order.

## 9.10 Card file screen

The list of files stored in the CF card is displayed. The start date and time, the end date and time (the latest data time for a file being recorded) and the data count are displayed. The files are displayed in the reverse chronological order (latest on the top). All files only of the selected group are displayed.

The selected row is displayed in yellow.

| Start date and time | End date and time   | Data count |
|---------------------|---------------------|------------|
| 2006/06/08 16:49:36 | 2006/06/08 16:50:30 | 542        |
| 2006/06/08 16:40:30 | 2006/06/08 16:49:35 | 5460       |
| 2006/06/08 16:31:30 | 2006/06/08 16:32:26 | 569        |
| 2006/06/08 16:24:35 | 2006/06/08 16:24:42 | 74         |
| 2006/06/08 16:19:11 | 2006/06/08 16:19:27 | 161        |
| 2006/06/08 16:15:59 | 2006/06/08 16:16:36 | 373        |
| 2006/06/08 15:59:10 | 2006/06/08 16:00:10 | 601        |
| 2006/06/08 15:58:25 | 2006/06/08 15:58:25 | 1          |
| 2006/06/08 15:55:26 | 2006/06/08 15:55:26 | 1          |
| 2006/06/08 15:53:51 | 2006/06/08 15:54:51 | 601        |
| 2006/06/08 15:53:07 | 2006/06/08 15:53:07 | 1          |
| 2006/06/08 15:49:22 | 2006/06/08 15:49:22 | 1          |
| 2006/06/08 15:43:38 | 2006/06/08 15:43:38 | 1          |
| 2006/06/08 15:42:05 | 2006/06/08 15:42:05 | 1          |
| 2006/06/08 15:41:28 | 2006/06/08 15:41:28 | 1          |
| 2006/06/08 15:40:01 | 2006/06/08 15:40:01 | 1          |
| 2006/06/08 15:40:01 | 2006/06/08 15:40:01 | 1          |

ENTER menu function

|               |  |
|---------------|--|
| Trend display | The trends recorded in the file of the selected row are displayed. (Binary only) |
|---------------|--|

Key operations other than the common operations (Para. 9.1)

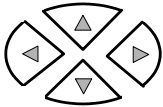

Up and down key: Moving the selected row  
Left and right key: Not used



Press this key to switch to the scroll mode. When this key is pressed once, the scroll bar is enclosed with a yellow frame and the scroll mode becomes ON. In this status, by pressing the direction key, the trends are scrolled one screen by one screen. When the scroll key is pressed again, the scroll mode becomes OFF and the trends are scrolled one line by one line by pressing the direction key.

## 9.11 Marker list screen

The list of markers recorded on the trends is displayed. The date and time and the marker text are displayed in the reverse chronological order (latest on the top). The markers recorded in the selected group are displayed. Maximum 200 markers are recorded. When the recorded marker exceeds 200, the markers are deleted in chronological order.

The selected row is displayed in yellow.

| Date and time  | Marker text                      |
|----------------|----------------------------------|
| 06/08 14:39:28 | MOTOR ON                         |
| 06/08 14:38:00 | Mark A                           |
| 06/02 11:31:03 |                                  |
| 06/02 11:19:32 | BBBB                             |
| 06/02 11:19:28 | AAAAAAAAAAAAAAAAAAAAAAAAAAAAAAAA |
| 05/19 14:23:09 | BBBB                             |
| 05/19 14:22:56 | AAAA                             |
| 05/19 14:22:32 | AAAA                             |
| 05/19 14:22:15 | BBBB                             |
| 05/19 14:22:11 | AAAA                             |
| 05/18 17:14:43 |                                  |

ENTER menu function

|               |  |
|---------------|--|
| Trend display | The screen is jumped to the trend position of the marker of the selected row. When the file is not found, the screen cannot be jumped. |
|---------------|--|

Key operations other than the common operations (Para. 9.1)

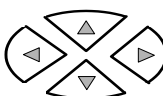

Up and down key: Moving the row for selection  
Left and right key: Not used



Press this key to switch to the scroll mode. When this key is pressed once, the scroll bar is enclosed with a yellow frame and the scroll mode becomes ON. In this status, by pressing the direction key, the trends are scrolled one screen by one screen. When the scroll key is pressed again, the scroll mode becomes OFF and the trends are scrolled one line by one line by pressing the direction key.

# 10 Initial settings

When the power supply is turned on under the default settings at the factory or when the settings are initialized, the initial settings screen is displayed. Set the indispensable following parameters on use.

You can exit without setting the parameters. In that case, this recorder operates with the default settings at the factory.

- Language
- Power frequency 50Hz/60Hz
- Clock settings
- Input settings
- Display settings
- File settings

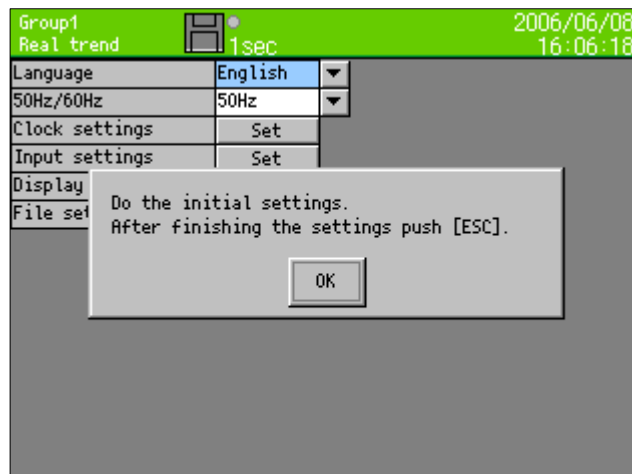

By pressing the ENTER key, the message disappears and the settings are enabled.

## (1) Setting of the language

By moving to the cursor to the item of the Language with the direction key and pressing the ENTER key, pulldown menu is displayed.

Select English or Japanese in the pulldown menu and press the ENTER key for setting.

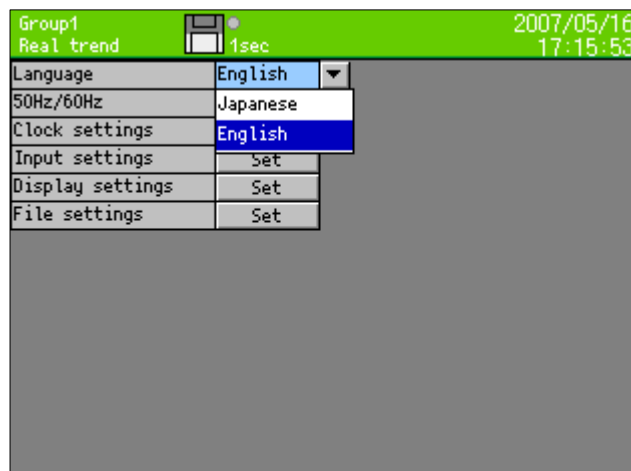



## (2) Setting of the power frequency

By moving the cursor to the item of the 50Hz/60Hz with the direction key and pressing the ENTER key, pulldown menu is displayed.

Select 50Hz or 60Hz in the pulldown menu and press the ENTER key.

Confirm and set the power frequency being used.

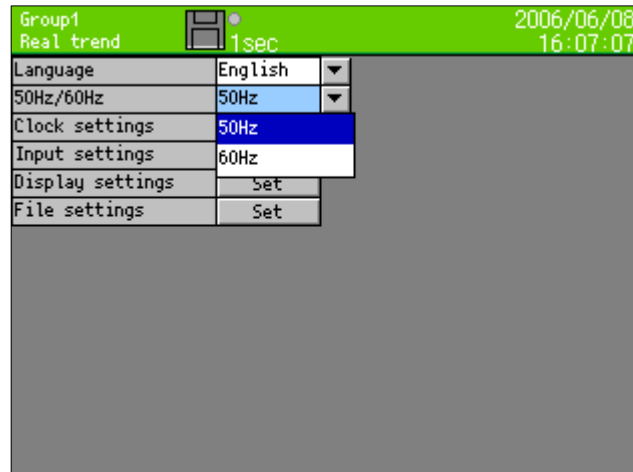

## (3) Clock settings

By moving the cursor to the item of clock settings with the direction key and pressing the ENTER key, the following clock settings screen is displayed.

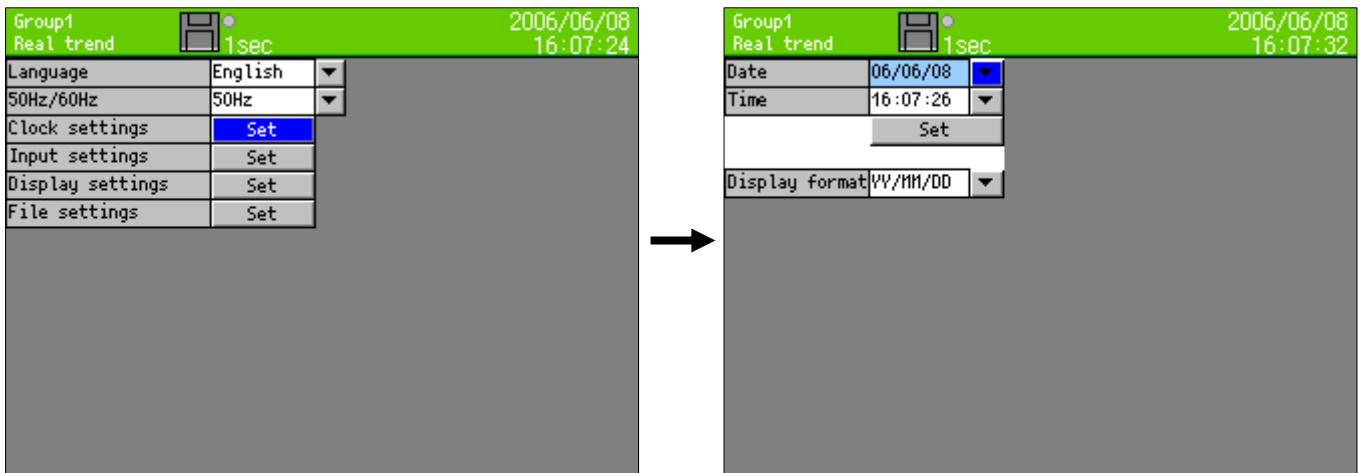

※For detailed settings refer to “13.11.1 Clock settings”

#### (4) Input settings

By moving the cursor to the item of the input setting with the direction key and pressing the ENTER key, the following input settings screen is displayed.

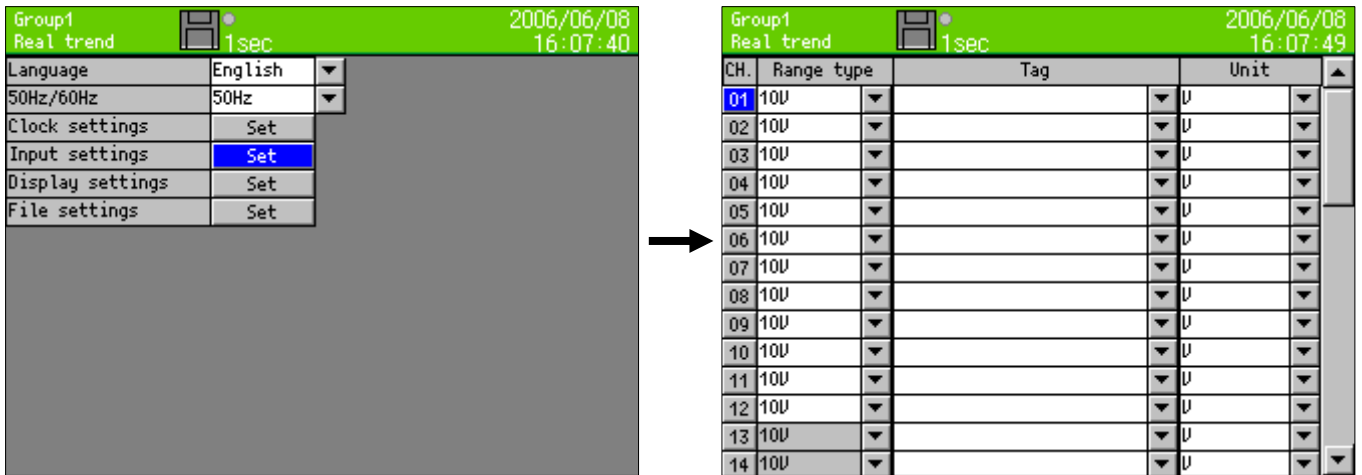

※For detailed settings refer to “13.2 Input operation settings”

#### (5) Display settings

By moving the cursor to the item of the display setting with the direction key and pressing the ENTER key, the following display settings screen is displayed.

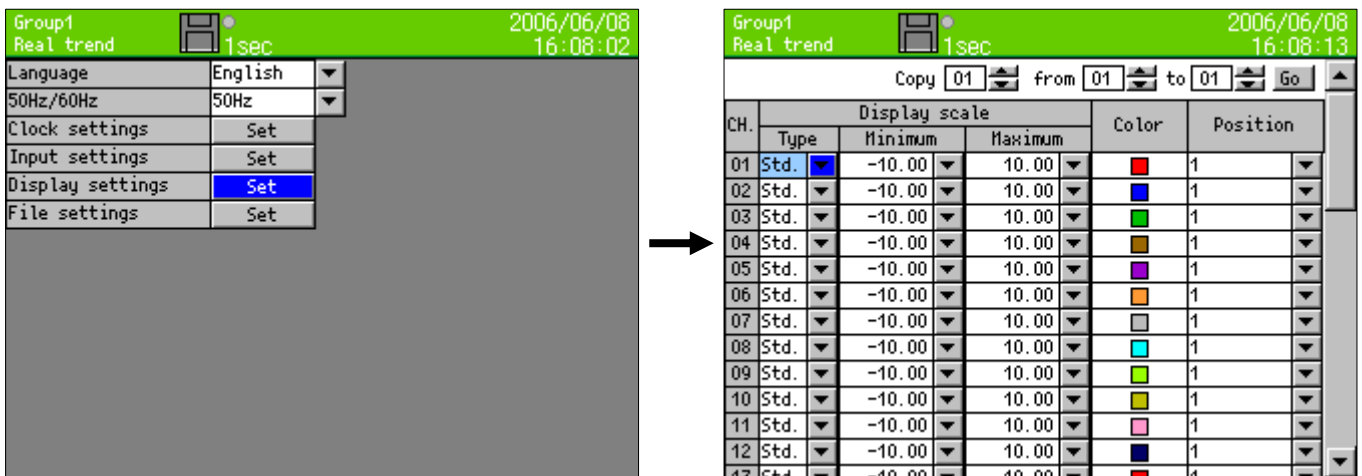

※For detailed settings refer to “13.3.1 Channel parameters”.

## (6) File settings

By moving the cursor to the item of the file setting with the direction key and pressing the ENTER key, the following file settings screen is displayed.

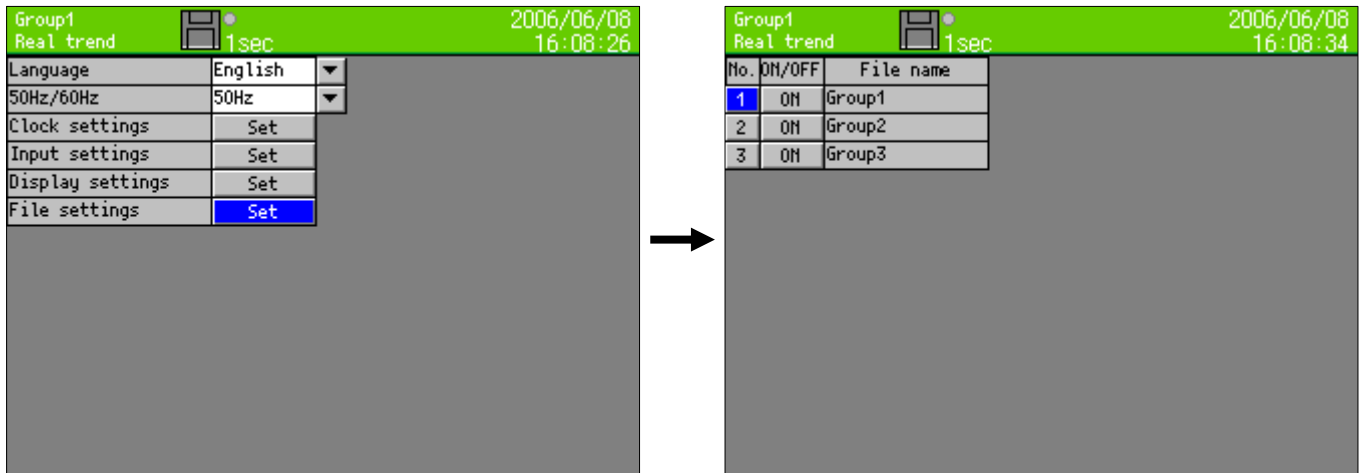

※For detailed settings refer to “13.5 File settings”.

# 11 Flow chart of HOME settings & MENU settings

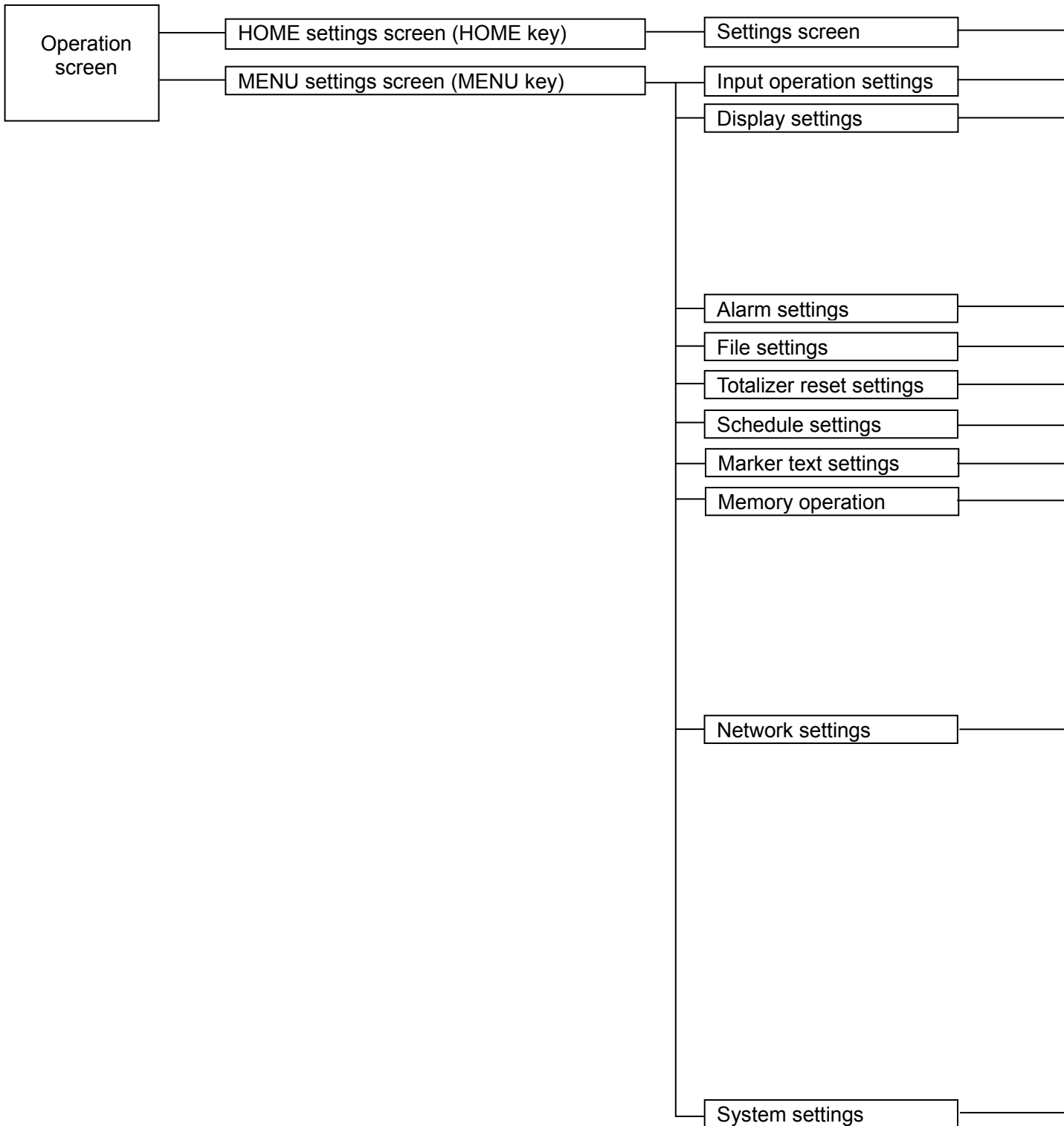

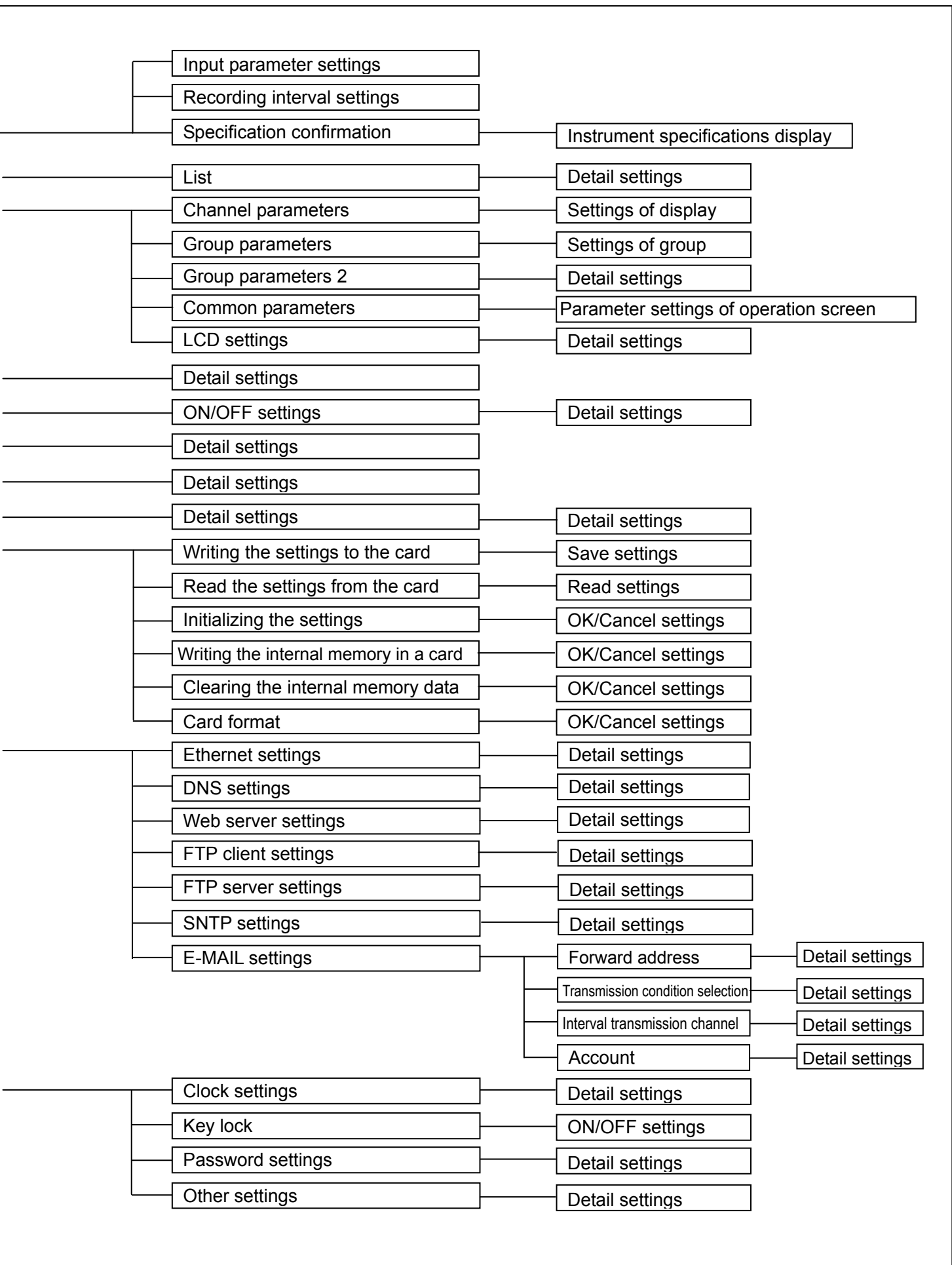

# 12 HOME settings

## 12.1 Setting with HOME settings

When the [HOME settings] is used, the inputs and recordings of all channels together can be set for the confirmation of input/recording simply.

### □ Operation screen

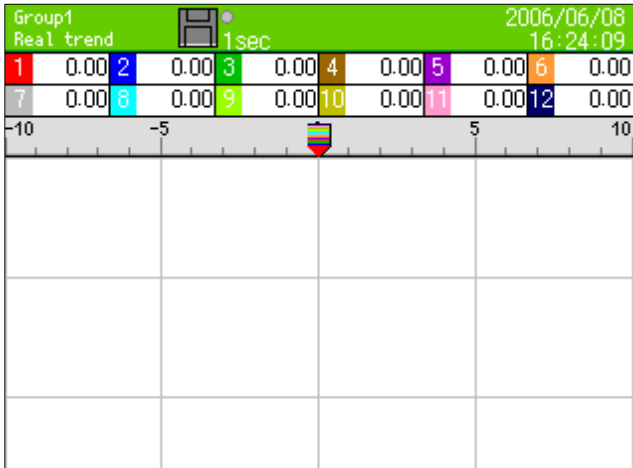

Press the HOME key



### □ Home settings screen

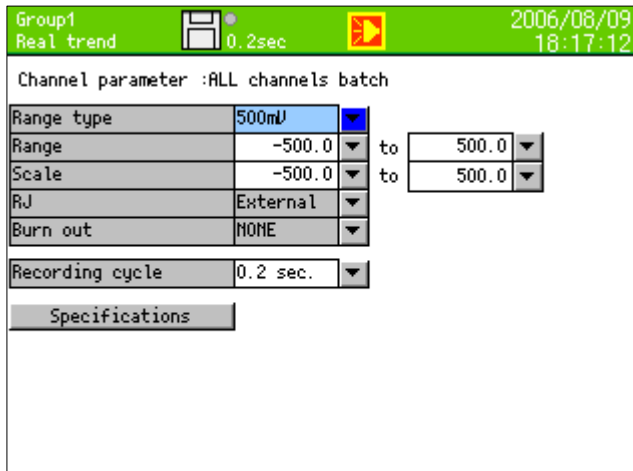

Press the HOME key on the operation screen to move to the HOME settings. For the settings, move the cursor (blue) to the desired item with the direction key and press the ENTER key. Then a selection screen is displayed for setting.

- Move the focus (blue) to the setting item with the direction key.
- By pressing the ENTER key, the setting item is set.

### ■ Setting the range type

|                        |  |
|------------------------|--|
| DC voltage             | 13.8mV, 27.6mV, 69mV, 200mV, 500mV, 2V, 5V, 10V, 20V, 50V                  |
| Thermocouple           | K, E, J, T, R, S, B, N, W-Wre26, PR40-20, NiMO-Ni, CR-AuFe,Platinel2, U, L |
| Resistance thermometer | Pt100, JPt100, Pt50, Pt-Co   |

### ■ Setting the range

- Set the range.(It is decided by range type.)

■ Setting the scale

- Set the scale. (It is decided by range type.)

| Number | Point |
|--------|-------|
| 10.00  | 2     |



This numeric value decides the position of the decimal point.

■ Setting the RJ (Reference junction compensation)

- Set whether the RJ is internal or external.

■ Setting the burn out

|      |                                   |
|------|-----------------------------------|
| None | The burnout function is not used. |
| UP   | Set to the upscale burnout.       |
| DOWN | Set to the downscale burnout.     |

■ Set the recording cycle

|        |  |
|--------|--|
| Second | 0.1 seconds, 0.2 seconds, 0.5 seconds, 1 second, 2 seconds, 3 seconds, 5 seconds, 10 seconds, 15 seconds, 20 seconds, 30 seconds |
| Minute | 1 minute, 2 minutes, 3 minutes, 5 minutes, 10 minutes, 15 minutes, 20 minutes, 30 minutes, 60 minutes                            |

\*When recording cycle is set less than 0.5 seconds (0.1-0.5 seconds) at the KR2161/2121, input channel numbers become 4 points automatically.

## 12.2 Confirming the specifications with HOME settings screen

- The information of specifications of this recorder can be confirmed.
- When you have any question on this recorder, contact your nearest distributor after confirming specifications by this screen.

### □ Operation screen

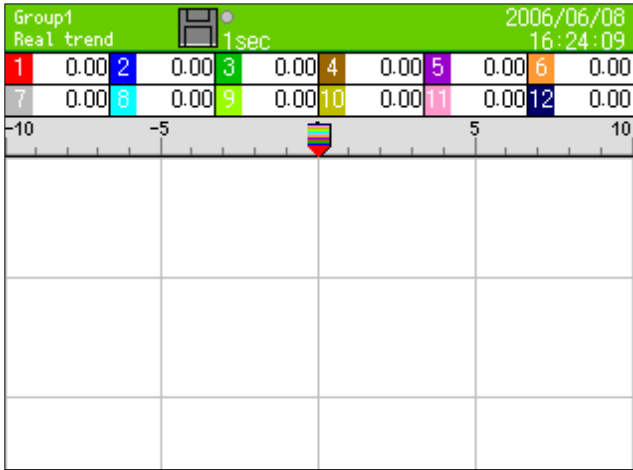

↓ Press the  key

### □ Home settings screen

↓  Press the  key

Selection: Move the cursor to "Specifications" with the "↓" of the direction key.

### □ Specifications confirmation screen

In the specifications confirmation screen, the followings can be confirmed.

- Model
- Serial number
- Software version
- MAC address.



# 13 MENU settings

## 13.1 Setting MENU settings screen

### □ Operation screen

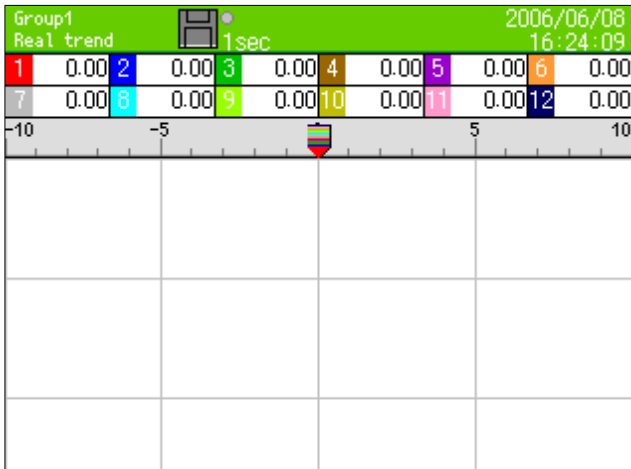

↓ Press the **MENU** key.

For setting parameter, press the MENU key on the operation screen to display the parameter items.  
By selecting the desired item with the direction key and pressing the ENTER key, the screen is switched to the parameter setting screen of this item.

### □ Settings menu screen

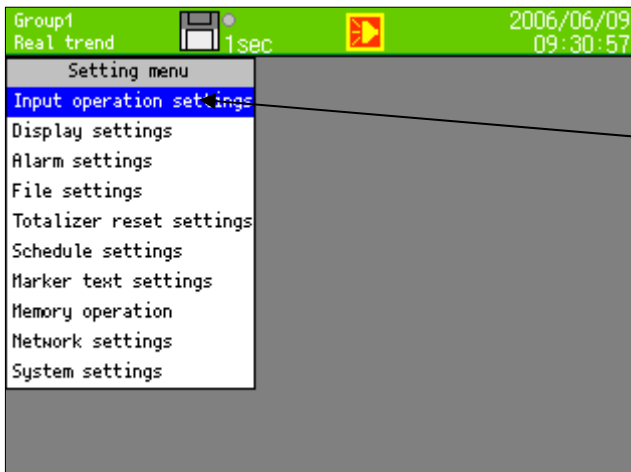

The list box of the parameters is displayed. Select the parameter item to be set by moving the cursor to the parameter with the up and down keys. The selected items are as shown on the left. (Example, at the time of selection of input operation settings)

### □ “Input operation settings” screen

Selection in the “Input operation settings”

Press the **ENTER** key.

| CH. | Range type | Tag | Unit |
|-----|------------|-----|------|
| 01  | 10V        |     | V    |
| 02  | 10V        |     | V    |
| 03  | 10V        |     | V    |
| 04  | 10V        |     | V    |
| 05  | 10V        |     | V    |
| 06  | 10V        |     | V    |
| 07  | 10V        |     | V    |
| 08  | 10V        |     | V    |
| 09  | 10V        |     | V    |
| 10  | 10V        |     | V    |
| 11  | 10V        |     | V    |
| 12  | 10V        |     | V    |
| 13  | 10V        |     | V    |
| 14  | 10V        |     | V    |

Input operation settings  
Refer to “13.2 Input operation settings”.

□ Display settings screen

Selection in the “Display settings”

Press the  key.

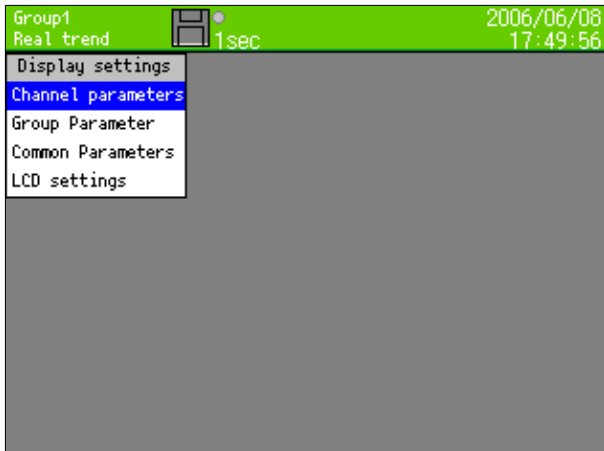

Display settings  
Refer to “13.3 Display settings”.

□ Alarm settings screen

Selection in the “Alarm settings”

Press the  key.

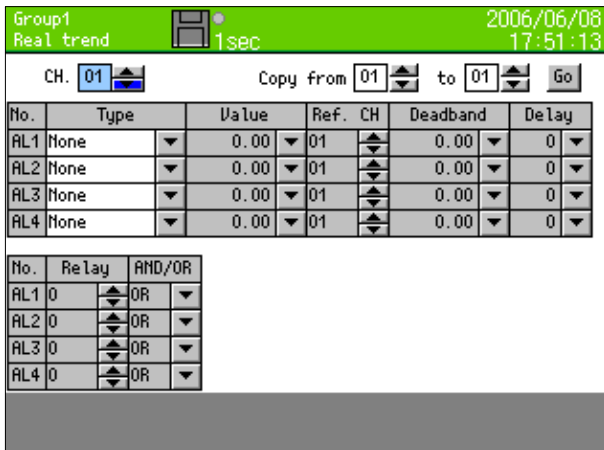

Alarm settings  
Refer to “13.4 Alarm settings”.

□ File settings screen

Selection in the “File settings”

Press the  key.



File settings  
Refer to “13.5 File settings”.

□ Totalizer reset settings screen

Selection in the “Totalizer reset settings”

Press the  key.

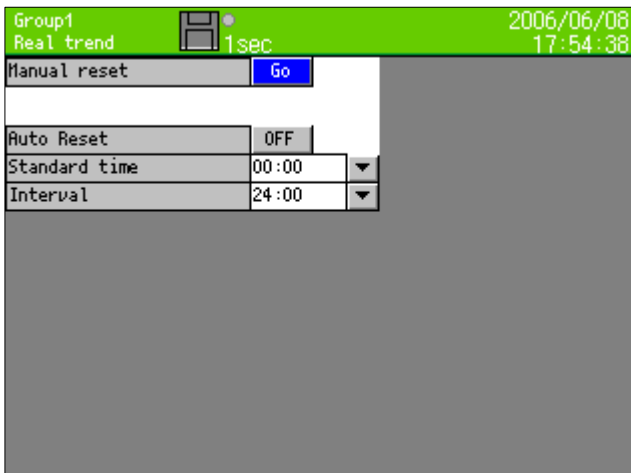

Totalizer reset settings  
Refer to “13.6 Totalizer reset settings”.

□ Schedule settings screen

Selection in the “Schedule settings”

Press the  key.

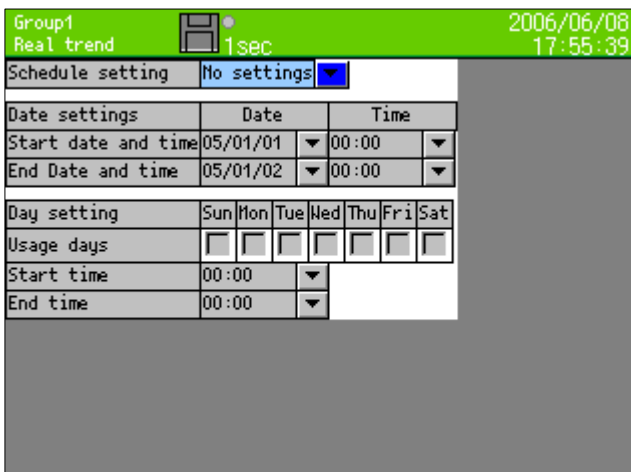

Schedule settings  
Refer to “13.7 Schedule settings”.

□ Marker text settings screen

Selection in the “Marker text settings”

Press the  key.

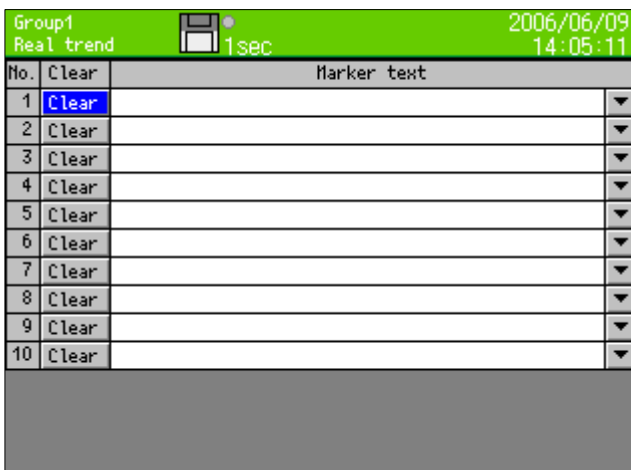

Marker text settings  
Refer to “13.8 Marker text settings”.

□ Memory operation screen

Selection in the “Memory operation”

Press the  key.

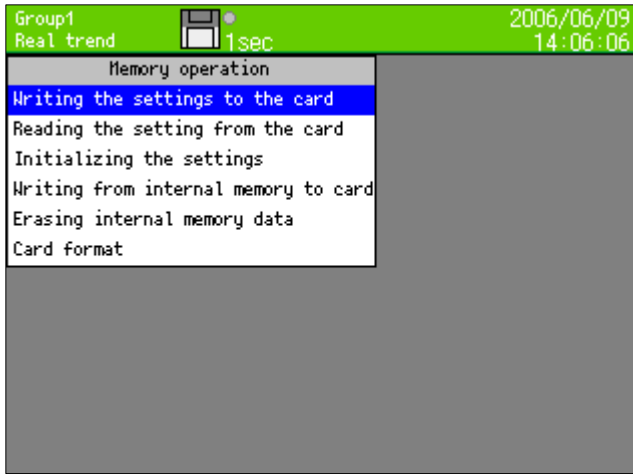

Memory operation  
Refer to “13.9. Memory operation”.

□ Network settings screen

Selection in the “Network settings”

Press the  key.

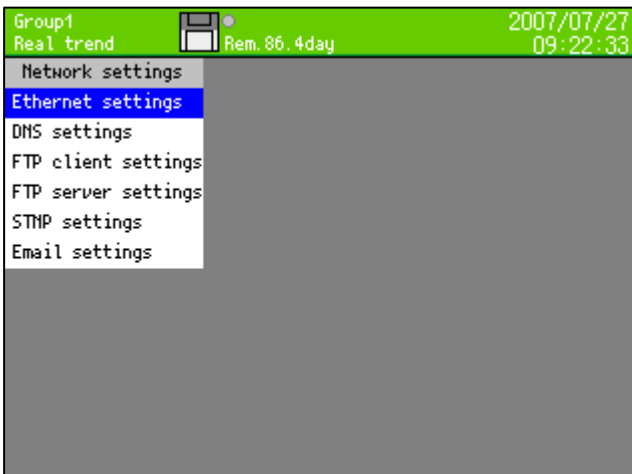

Network settings  
Refer to “13.10. Network settings”.

□ System settings screen

Selection in the “System settings”

Press the  key.

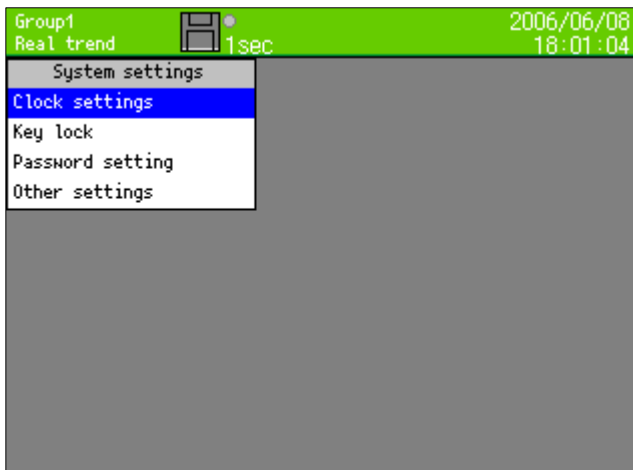

System settings  
Refer to “13.11. System settings”.

## 13.2 Input operation settings

### 13.2.1 Setting contents

- Proceed from the MENU settings
- Move the focus to the setting item with the direction key.
- By pressing the ENTER key on the item for setting, the screen moves to the input screen.

By selecting the “Input operation settings” on the setting menu screen, the following screen is displayed.

| CH. | Range type | Tag | Unit |
|-----|------------|-----|------|
| 01  | 10V        |     | V    |
| 02  | 10V        |     | V    |
| 03  | 10V        |     | V    |
| 04  | 10V        |     | V    |
| 05  | 10V        |     | V    |
| 06  | 10V        |     | V    |
| 07  | 10V        |     | V    |
| 08  | 10V        |     | V    |
| 09  | 10V        |     | V    |
| 10  | 10V        |     | V    |
| 11  | 10V        |     | V    |
| 12  | 10V        |     | V    |
| 13  | 10V        |     | V    |
| 14  | 10V        |     | V    |

By moving the focus a CH number and pressing the ENTER key, the detailed setting screen for this channel is displayed.

Group1 Real trend 1sec 2007/07/27 09:23:40

CH. 01 Copy from 01 to 01 Go

Range type 10V

Range -10.00 to 10.00

Scale -10.00 to 10.00

Correction 0.00

RJ ----

Burn out ----

Filter Level System settings

Tag

Unit V

Calculate OFF

Formula

■ Setting range type

(Analog input) KR2120: CH1-12, KR2160: CH1-6

|                        |  |
|------------------------|--|
| DC voltage             | 13.8mV, 27.6mV, 69mV, 200mV, 500mV, 2V, 5V, 10V, 20V, 50V                              |
| Thermocouple           | K, E, J, T, R, S, B, N, W-WRe26, WRe5-WRe26, PR40-20, NiMo-Ni, CR-AuFe,Platinel2, U, L |
| Resistance thermometer | Pt100, JPt100, Pt50, Pt-Co   |

(Digital input) \*For the optional digital input specified CH37-44

|               |                    |
|---------------|--------------------|
| Digital input | DI                 |
| Pulse input   | Pulse(+), Pulse(-) |

■ Setting the range

- Set the range. (It is decided by range type.)

■ Setting the scale

- Set the scale. (It is decided by range type.)

|        |       |   |
|--------|-------|---|
| Number | Point |   |
| 10.00  | 2     | ← This numeric value decides the position of the decimal point. |

■ Setting sensor correction

- Set the a value (shift value) added to the input value.

■ Setting the RJ (Reference junction compensation)

- Set whether the RJ is internal or external.

■ Setting burn out

|      |                                   |
|------|-----------------------------------|
| None | The burnout function is not used. |
| UP   | Set to the upscale burnout.       |
| DOWN | Set to the downscale burnout.     |

■ Setting the filter level

- The input filter level can be set from 0 to 3. 0 means no-filter, and 3 means the strongest filter. When [system settings] is selected, settings are following [system settings] – [other settings].

■ Setting the tag

- Set the tag name (Setting for displaying the tag name instead of channel number.)

■ Setting the unit

- Set the engineering unit of its channel

■ Setting the usage of calculation

|     |  |
|-----|--|
| OFF | The input data are displayed and recorded as the measured date of its channel.                                   |
| ON  | The results processed by the calculation formula are displayed and recorded as the measured data of its channel. |

■ Setting the formula

- When calculation usage is ON, set the formula of its channel.

■ Copying the parameter with copy function

|        |              |    |    |    |    |    |
|--------|--------------|----|----|----|----|----|
| Ch. 01 | Copy from 02 | ▲▼ | to | 05 | ▲▼ | Go |
|--------|--------------|----|----|----|----|----|

The above shows the setting for copying Ch 01 from Ch 02 to Ch 05. By selecting the [Go] and pressing the ENTER key, the parameters of Channel 01 are copied from Channel 02 to Channel 05.

## 13.2.2 Setting method of formula

### 1) Formula types

#### Mathematical calculation

Four arithmetic operations are performed.

|                | Symbol | Example | Remarks |
|----------------|--------|---------|---------|
| Addition       | +      | $X+Y$   |         |
| Subtraction    | -      | $X-Y$   |         |
| Multiplication | *      | $X*Y$   |         |
| Division       | /      | $X/Y$   |         |
| Reminder       | %      | $X\%Y$  |         |
| Exponential    | ^      | $X^Y$   |         |

※X, Y indicate the formula or the numeric value.

#### Comparison calculation

The comparison calculation is performed and result is 1 (established) or 0 (not established)

|                    | Symbol | Example | Remarks |
|--------------------|--------|---------|---------|
| Equal value        | ==     | $X==Y$  |         |
| Unequal value      | !=     | $X!=Y$  |         |
| More than          | >>     | $X>>Y$  |         |
| Less than          | <<     | $X<<Y$  |         |
| Equal or more than | >=     | $X>=Y$  |         |
| Equal or less than | <=     | $X<=Y$  |         |

※X, Y indicate the formula or the numeric value.

#### Logical operation

The logical operations for 1 or 0 are performed and the result is returned as 1 or 0.

|              | Symbol | Example       | Remarks                                   |
|--------------|--------|---------------|---|
| Logical AND  | AND    | $XANDY$       |   |
| Logical OR   | OR     | $XORY$        |   |
| Exclusive OR | XOR    | $XXORY$       |   |
| Negation     | NOT    | <b>NOT(X)</b> | Put the object being negation in brackets |

※X, Y indicate the formula or the numeric value. Express X and Y as 0 or 1.

#### General calculation function

Function calculation is performed.

|                                 | Symbol | Example         | Remarks |
|---------------------------------|--------|-----------------|---------|
| Round up after the decimal      | CEL    | <b>CEL(X)</b>   |         |
| Round down after the decimal    | FLR    | <b>FLR(X)</b>   |         |
| Absolute value                  | ABS    | <b>ABS(X)</b>   |         |
| Square root                     | SQR    | <b>SQR(X)</b>   |         |
| Power of e                      | EXP    | <b>EXP(X)</b>   |         |
| Natural logarithm (base is e)   | LOG    | <b>LOG(X)</b>   |         |
| Common logarithm (bottom is 10) | LOG10  | <b>LOG10(X)</b> |         |

※X indicates the formula or the numeric value.

### Channel data calculation functions

The function calculation is performed.

When an error data (OVER, UNDER etc.) is included in the measured data, it becomes "CAL ER".

|                                 | Symbol | Example            | Remarks  |
|---------------------------------|--------|--------------------|--|
| Measured data                   | CH     | <b>CH(X)</b>       | X is channel No.                                   |
| Calculation result data         | PCH    | <b>PCH(X)</b>      |  |
| Previous calculated result data | OCH    | <b>OCH(X)</b>      | Data at the previous scanning (before 0.1 seconds) |
| Totalizer                       | ITG    | <b>ITG(X)</b>      | Refer to 2) Totalizing operation                   |
| F value                         | FV     | <b>FV(X#T#Z#R)</b> | Refer to 3) F value                                |
| Relative humidity               | RH     | <b>RH(D#W)</b>     | Refer to 4) Relative humidity                      |
| Dew-point temperature           | DEW    | <b>DEW(T#H)</b>    | Refer to 5) Dew-point temperature                  |
| Moving average (an hour)        | AVE    | <b>AVE(X#T)</b>    | Refer to 6) Moving average                         |
| Moving average (5 minutes)      | AVEH   | <b>AVEH(X#T)</b>   | Refer to 6) Moving average                         |
| Past data (an hour)             | OLD    | <b>OLD(X#T)</b>    | Refer to 7) Past data                              |
| Past data (5 minutes)           | OLDH   | <b>OLDH(X#T)</b>   | Refer to 7) Past data                              |
| First-order leg filter          | IIR    | <b>IIR(X#T)</b>    | Refer to 8) First- order filter                    |
| Increment per time              | PLS    | <b>PLS(X#T)</b>    | Refer to 9) Increment per time                     |

※ X indicates channel number.

\* When the channel data calculation is specified for executing with the settings of the designated channel number, the calculated results of the designated channel number are used. In addition, when the designated channel number is greater than the channel number for calculation, the calculation results obtained previously at the designated channel are used.

### System information acquisition function

|                          | Symbol | Example      | Remarks  |
|--------------------------|--------|--------------|--|
| CF card remaining amount | CF     | <b>CF(A)</b> | A= Unit of remaining amount<br>0: MB<br>1: Minute<br>2: Hour<br>3: Day |

### Other function

|              | Symbol | Example       | Remarks                  |
|--------------|--------|---------------|--------------------------|
| Wind display | AZI    | <b>AZI(A)</b> | Refer to 9) Wind display |



## 2) Totalizing operation

For the totalizer, the ITG function or the ITG24 function is used.

Do not use totalizing function more than two times in one formula. The results are not calculated correctly. The totalizing function can be used in calculations other than the totalizer.

Example : ~~ITG(1)+ITG(2)~~, ~~ITG24(1)-ITG(1)~~, ITG(1)100

For the totalizer rest, refer to Para. 13.6.

### 1. Standard totalizing operation

The totalized values are reset at the totalizer reset reference time or every interval.

Entering method of the formula

**ITG(d)**

d: Channel number to be totalized

Calculation contents

$$D_n = D_{n-1} + \{(PV_n + PV_{n-1}) \times (T_n - T_{n-1})\} \div 2$$

$D_n$  : Totalized result                       $D_{n-1}$  : Previous totalized result

$PV_n$  : Data to be totalized                       $PV_{n-1}$  : Data totalized at the previous calculation

$T_n$  : Time of calculation                       $T_{n-1}$  : Time of the previous calculation (before 0.1 seconds)

When error data (OVER, UNDER etc.) are included, calculation is not performed and the previous result are used.

### 2. 24-hours totalizing operation

The totalized values are reset only at the totalizer rest reference time or at every interval.

Entering method of the formula

**ITG24(d)**

d: Channel number to be totalized

The calculation contents are same as standard totalizing operation.

\*Totalizer is performed every 0.1 seconds regardless of measurement cycle (either KR21\*0 and 21\*1).

## 3) F value

Entering method of the formula

FV(X#To#Z#R)

X: Channel to be calculated, To: F-value calculation reference temperature, Z: Z-value,  
R: F-value calculation starting temperature

The following formula is used for the F-value calculation.

$$\int 10^A dt \quad \text{Provision: } A = (T - T_o) \div Z \quad T: \text{channel data to be calculated}$$

When T exceeds R, the F-value is reset to 0.

## 4) Relative humidity

Entering method of the formula

RH (D#W)

D: Dry bulb temperature, W: Wet bulb temperature

The following formula is used for the relative humidity calculation.

$$((B - 0.000662 \times 1013.0 \times (D - W)) \div A) \times 100$$

Provision: A: Dry bulb saturated water vapor pressure, B: Wet bulb saturated water vapor pressure

The following formula is used for the calculation of the saturated water vapor pressure

$$6.1121 \times E \times P \left( (17.502 \times T) \div (240.9 + T) \right) \quad T: \text{Humidity}$$

## 5) Dew-point temperature

Entering method of the formula

DEW (T#H)

T: Temperature data channel, H: Relative humidity channel

The following formula is used for the dew-point temperature.

t: Temperature data

h: Relative humidity data

D: Dew-point temperature

$$\textcircled{1} K = t + 273.15$$

$$\textcircled{2} \text{In case of } t \geq 0$$

$$W = \text{EXP} \left( \frac{-5800.2206}{K} + 1.3914993 + K \times (-0.048640239 + K \times (0.41764768E-4 - 0.14452093E-7 \times K)) \right) + 6.5459673 \times \text{LOG} (K) \bigg/ 1000$$

In case of  $t < 0$

$$W = \text{EXP} \left( \frac{-5674.5359}{K} + 6.3925247 + K \times (-9.677843E-3 + K \times (0.62215701E-6 + K \times (0.20747825E-8 - 9.484024E-13 \times K))) \right) + 4.1635019 \times \text{LOG} (K) \bigg/ 1000$$

$$\textcircled{3} S = W \times h \bigg/ 100$$

$$\textcircled{4} P = S \times 1000$$

$$\textcircled{5} Y = \text{LOG} (P)$$

$$\textcircled{6} \text{In case of } P \geq 611.2$$

$$D = -77.199 + Y \times (13.198 + Y \times (-0.63772 + 0.071098 \times Y))$$

In case of  $P < 611.2$

$$D = -60.662 + Y \times (7.4624 + Y \times (0.20594 + 0.016321 \times Y))$$

## 6) Moving average

Entering method of the formula

AVE (X#T)

AVEH (X#T)

X: Data channel number, T: Time series interval (second)

Mean value of past T seconds is calculated.

Difference between AVE and AVEH are the following.

|                | AVE       | AVEH        |
|----------------|-----------|-------------|
| Sampling cycle | 1 second  | 0.1 seconds |
| Range of T     | 1 to 3600 | 1 to 300    |

## 7) Past data

Entering method of the formula

OLD (X#T)

OLDH (X#T)

X: Data channel number, T: Time in which go back (second)

Mean value of past T seconds is calculated.

Difference between OLD and OLDH are the following.

|                | OLD       | OLDH        |
|----------------|-----------|-------------|
| Sampling cycle | 1 second  | 0.1 seconds |
| Range of T     | 1 to 3600 | 1 to 300    |

## 8) First-order leg filter

Entering method of the formula

IIR (X#T)

X: Data channel number, T: Time constant (second)

First-order calculate is performed in the data of channel X.

Contents of calculation

$$\{dt \div (dt+t)\} \times (x-d) + d$$

dt: Sampling cycle (0.1 seconds fixed), t: time constant, x: current value of channel X, d: previous calculation result

## 9) Increment per time

Entering method of the formula

PLS (X#T)

X: Data channel number, T: Unit time (second)

Calculate increment per unit time T. X is specified from the channel that is set totalizer or the channel that is selected pulse range in 37 to 44.

## 10) Wind display

Entering method of the formula

AZI (A)

A: Wind data

Display the compass point which is changed from direction.

Relation of the displayed direction of wind data is in the following list.

If A is fractional value, display closest direction. Example: 1.2 → NNE

| A  | Display |
|----|---------|
| •  | •       |
| •  | •       |
| •  | •       |
| -3 | WNW     |
| -2 | NW      |
| -1 | NNW     |
| 0  | N       |
| 1  | NNE     |
| 2  | NE      |
| 3  | ENE     |
| 4  | E       |
| 5  | ESE     |
| 6  | SE      |
| 7  | SSE     |
| 8  | S       |
| 9  | SSW     |
| 10 | SW      |
| 11 | WSW     |
| 12 | W       |
| 13 | WNW     |
| 14 | NW      |
| 15 | NNW     |
| 16 | N       |
| 17 | NNE     |
| 18 | NE      |
| •  | •       |
| •  | •       |
| •  | •       |

In addition, scale plate which is registered channel that is used this calculation is displayed wind scale.

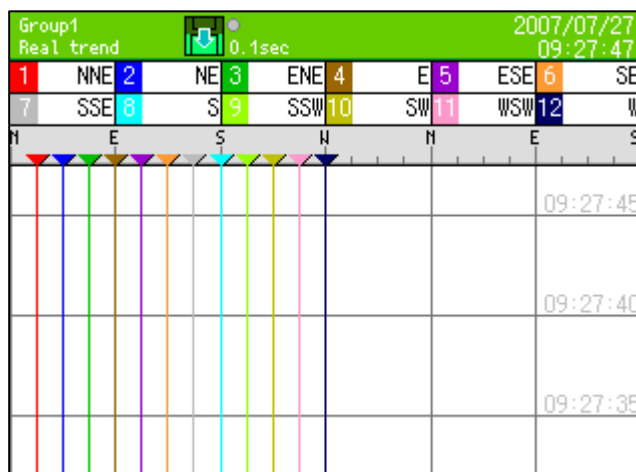

Display coordinate on the trend is same as normal numeric data.

## 11) Example of arithmetic expression where calculations are combined

- $(CH(1)*3-20)/6$   
("Raw data of channel 1" X 3 – 20) ÷ 6
- $(CH(1)+CH(2))<300$   
When the total of raw data of channel 1 and channel 2 is less than 300, it becomes 1.
- $ABS(CH(1))\geq 50$   
When absolute value of channel 1 is 50 or more, it becomes 1.
- $(PCH(1)\geq 100)AND(PCH(2)\leq 50)$   
When data of channel 1 is 100 or more and data of channel 2 is 50 or less, it becomes 1.

\*Note The following functions can not be used together. The results are not calculated correctly.  
ITG, AVE, AVEH, OLD, OLDH, IIR  
Example: AVE (OLD (1#10)#60) → NG

## 13.3 Display settings

### 13.3.1 Channel parameter

- Proceed from the MENU settings.
- Move the focus to the setting item using direction key.
- By pressing the ENTER key on the item for setting, the screen moves to the input screen.

By selecting the display settings on the setting menu screen and then selecting the channel parameters, the following screen is displayed.

Set the wave pattern type, maximum/minimum values of the display scale, color and the display position of each channel.

| CH. | Display scale |         |         | Color       | Position |
|-----|---------------|---------|---------|-------------|----------|
|     | Type          | Minimum | Maximum |             |          |
| 01  | Std.          | -10.00  | 10.00   | Red         | 1        |
| 02  | Std.          | -10.00  | 10.00   | Blue        | 1        |
| 03  | Std.          | -10.00  | 10.00   | Green       | 1        |
| 04  | Std.          | -10.00  | 10.00   | Brown       | 1        |
| 05  | Std.          | -10.00  | 10.00   | Purple      | 1        |
| 06  | Std.          | -10.00  | 10.00   | Orange      | 1        |
| 07  | Std.          | -10.00  | 10.00   | Grey        | 1        |
| 08  | Std.          | -10.00  | 10.00   | Cyan        | 1        |
| 09  | Std.          | -10.00  | 10.00   | Light Green | 1        |
| 10  | Std.          | -10.00  | 10.00   | Yellow      | 1        |
| 11  | Std.          | -10.00  | 10.00   | Pink        | 1        |
| 12  | Std.          | -10.00  | 10.00   | Dark Blue   | 1        |

#### ■ Setting the display scale

The data are displayed on the screen with the setting contents of the display scale.

| Item     | Contents  |
|----------|---|
| Type     | <p>“Standard”: Min and Max values can be set in the range of <math>\pm 30000</math>. The screen is displayed in the standard format.</p> <p>“Exponent”: Min and Max values are set in the exponent format. The screen is also displayed in the exponent format. The significant of Min and Max values is 1 to 9.99 and the exponent part can be set in the range of <math>\pm 15</math>.</p>  |
| Min, Max | <ul style="list-style-type: none"> <li>• In the trend display, the Min value is positioned at the extreme left (low) and the Max value is positioned at the extreme right (up) by coordinate calculation. ( ) for horizontal direction</li> <li>• When there are multiple channels displayed at the same position, the Min and Max values of the channel with the smallest number are displayed on the scale plate and the Min and Max values of each channel are used for the coordinate for each pen.</li> <li>• The Min and Max values are displayed with the number of digits after decimal point displayed in the screen.</li> </ul> |

■ Setting the display position

- The display position (1, 2, 3, and 4) indicates the position of scale plate.

For vertical trend graph

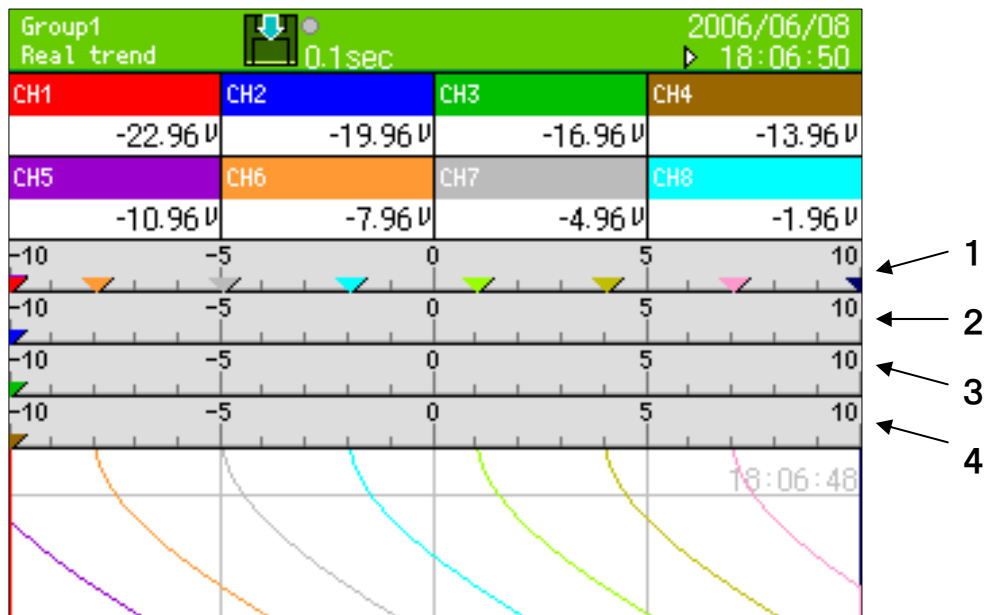

For horizontal trend graph

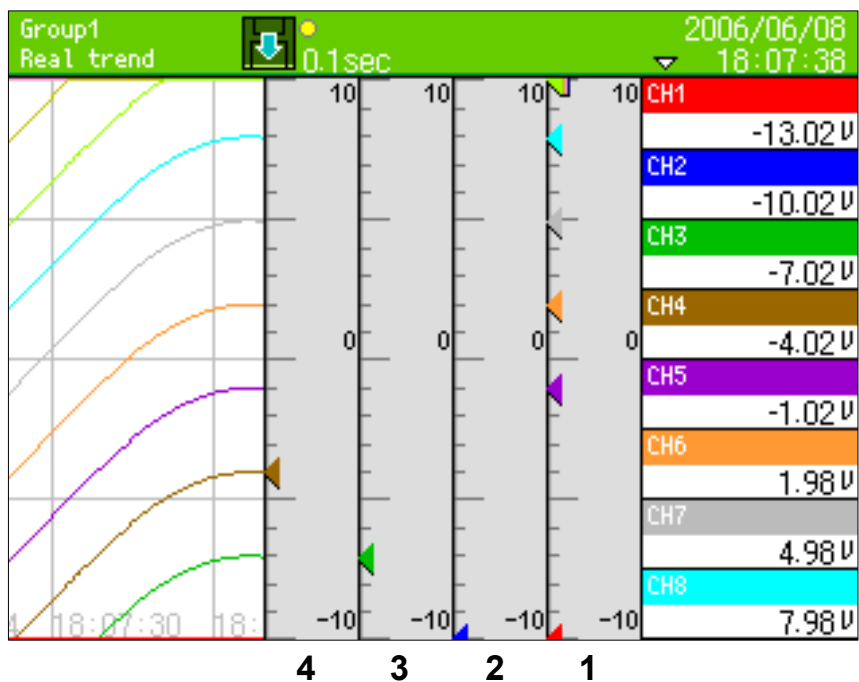

■ Copy the parameter using the copy function

Ch.  Copy from  to

The above shows the setting for copying Ch 01 from Ch 02 to Ch 05. By selecting the [Go] and pressing the ENTER key, the parameters of Channel 01 are copied from Channel 02 to Channel 05. Colors are not copied.

### 13.3.2 Group parameter

- Proceed from the MENU settings.
- Move the focus to the setting item using direction key.
- By pressing the ENTER key on the item for setting, the screen moves to the input screen.

By selecting the display settings on the setting menu screen and then selecting the group parameters, the following screen is displayed.

The group being specified by the number in the upper left "Group" can be set.

| Group1        |      | Real trend |    | 0.1sec |    | 2006/06/08 |   | 18:08:36 |  |
|---------------|------|------------|----|--------|----|------------|---|----------|--|
| Group         | 1    | Group name |    |        |    |            |   |          |  |
| Channel       | 01   | 02         | 03 | 04     | 05 | 06         |   |          |  |
| Trend display | Y    | Y          | Y  | Y      | Y  | Y          |   |          |  |
| Size          | 1    | 1          | 1  | 1      | 1  | 1          |   |          |  |
| Channel       | 07   | 08         | 09 | 10     | 11 | 12         |   |          |  |
| Trend display | Y    | Y          | Y  | Y      | Y  | Y          |   |          |  |
| Size          | 1    | 1          | 1  | 1      | 1  | 1          |   |          |  |
| Trip Line 1   | Posi | 0          | %  | Color  | ■  | Size       | 1 |          |  |
| Trip Line 2   | Posi | 0          | %  | Color  | ■  | Size       | 1 |          |  |
| Trip Line 3   | Posi | 0          | %  | Color  | ■  | Size       | 1 |          |  |
| Trip Line 4   | Posi | 0          | %  | Color  | ■  | Size       | 1 |          |  |

#### ■ Setting the group name

- Set the group name. This group name is used in the screen display and used as the file name of the recorded data.

#### ■ Channel

- Set the channel to be registered in the group. The registration is cancelled by setting blank (pressing the down-arrow at 1 or the up-arrow at 44).

#### ■ Trend display

- Every time the ENTER key is pressed after selecting "Y" and "N" are switched alternatively. The trend with N is not displayed even if the channel has been registered. The data of channel with N selected are not recorded in the file.

#### ■ Trend line size

- It is the thickness of the trend line. It can be selected from 1, 3, 5.

#### ■ Setting the trip line

Set the trip line (dotted line) to be displayed on the trends.

- Position  
Set the display position of the trip line in the range 0-99% of the display width.
- Color  
Select the color of the trip line.
- Size  
Select the thickness of the trip line from 1, 3 or 5



### 13.3.3 Group parameter 2

- Proceed from the MENU settings.
- Move the focus to the setting item using direction key.
- By pressing the ENTER key on the item for setting, the screen moves to the input screen.

By selecting the display settings on the setting menu screen and then selecting the group parameter 2, the following screen is displayed.

The group being specified by the number in the upper left "Group" can be set.

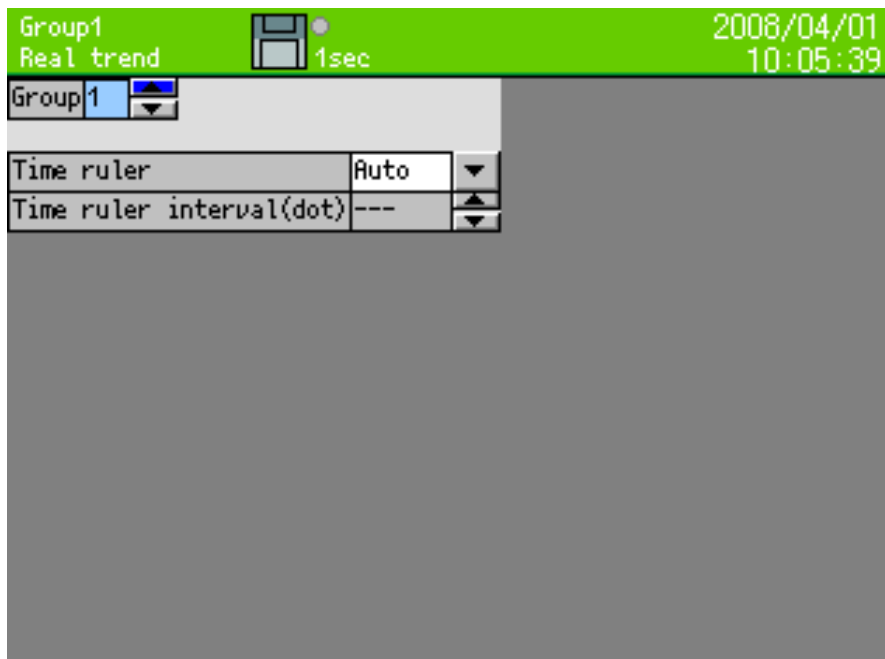

#### ■ Time ruler

Select auto or specified. In case of auto, ruled line interval is decided by recording interval.

#### ■ Time ruler interval (dot)

Time ruler interval of trend is specified. Even number of 12 to 510 can be set. This function is effected when select 'specified' in 'time ruler'.

### 13.3.4 Common parameters

- Proceed from the MENU settings.
- Move the focus to the setting item using direction key.
- By pressing the ENTER key on the item for setting, the screen moves to the input screen.

By selecting the display settings on the setting menu screen and then selecting the common parameters, the following screen is displayed.

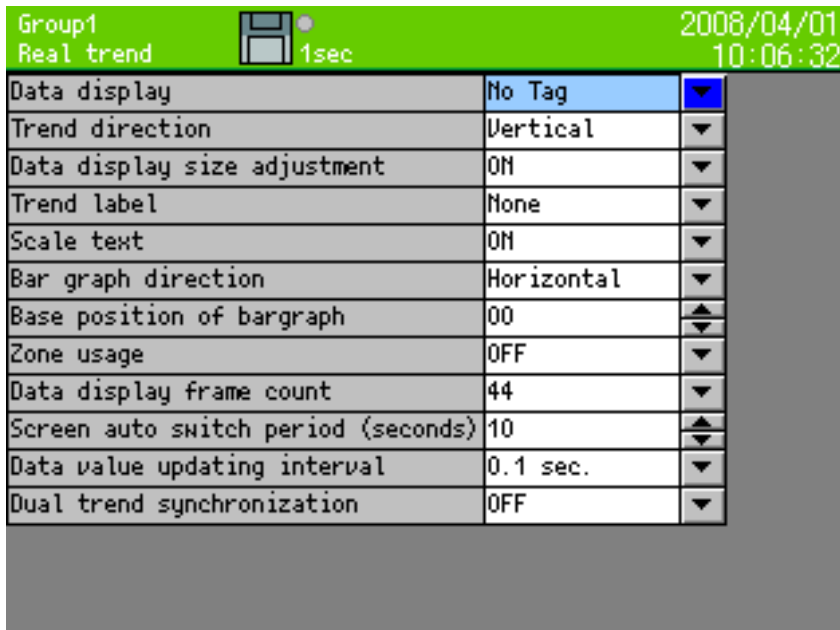

#### ■ Setting the data display

- Set the upper side (or right side) display of the trend screen to indicate the tag name, the bar graph or nothing.

|        |          |           |      |
|--------|----------|-----------|------|
| No tag | With tag | Bar graph | None |
|--------|----------|-----------|------|

#### ■ Setting the trend direction

- Set the waveform direction to be vertical or horizontal.

#### ■ Setting the data display size adjustment

- This is the function which automatically sizes up data display on the trend screen when registered channel numbers are small. In the following cases, data is displayed by larger font.

| Data display | Trend direction | Number of the registered CH |
|--------------|-----------------|-----------------------------|
| No tag       | Vertical        | Less than 3                 |
| With tag     | Vertical        | Less than 4                 |
| No tag       | Horizontal      | Less than 6                 |
| With tag     | Horiconatal     | Less than 4                 |

#### ■ Setting the trend label

- Set the label for displaying on the trend.

|     |         |     |
|-----|---------|-----|
| OFF | Channel | Tag |
|-----|---------|-----|

#### ■ Setting the scale text

- Set the scale plate to display the numerical values or not.

#### ■ Setting the bar graph direction

- Set the bar graph direction on the bar graph screen to be vertical or horizontal.

■ Setting the base position of the bar graph

- Set the base position of the bar graph from 0 to 100 on the bar graph screen. When the base position is 0, the bar is displayed based on leftmost (or bottommost). When the base position is 100, the bar is displayed based on rightmost (or uppermost).

When the base position is 0

When the base position is 50

When the base position is 100

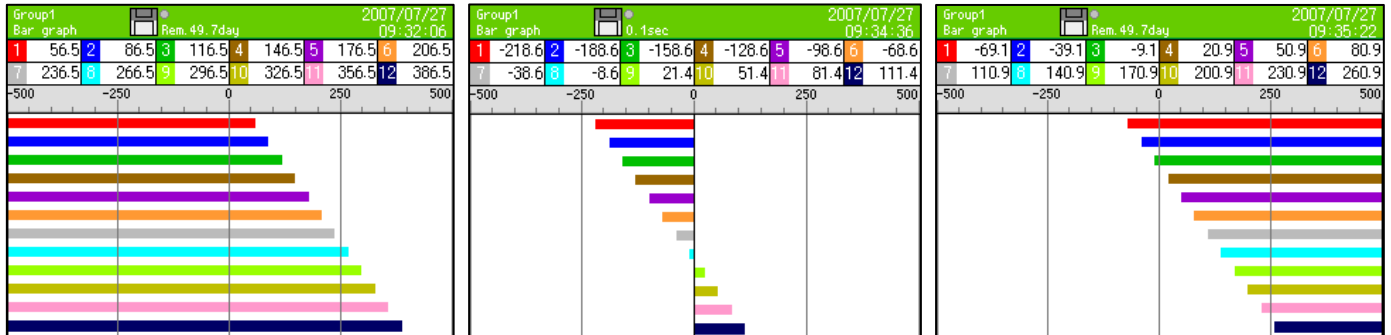

■ Setting zone usage

- The display range of the measured/calculated data is called zone. When the zone is set to ON, the display range can be divided into zones. The details are described in the next page.

■ Setting numeric display frame count

- Set the division number of the numeric display frame.

|   |   |   |   |   |   |   |    |    |    |    |
|---|---|---|---|---|---|---|----|----|----|----|
| 1 | 2 | 3 | 4 | 6 | 8 | 9 | 10 | 12 | 21 | 44 |
|---|---|---|---|---|---|---|----|----|----|----|

■ Screen auto switch period

- Set the switching period if the “Auto switching” has been set to ON with the DISP menu.

■ Numeric value update period

- Select the numeric value updating period of measured data to be displayed on the screen.

|             |             |          |
|-------------|-------------|----------|
| 0.1 seconds | 0.5 seconds | 1 second |
|-------------|-------------|----------|

■ Dual trend synchronization

- When previous file is opened by dual trend during ‘ON’, the file is scrolled as fast as real trend. When scroll end of the file, if there is continuous file, the file is opened automatically and scrolling is continued.

## Zone

The display range of the measured/calculated data is called zone. Since the data can be displayed by setting the zone for each channel, the data can be easily read by displaying the waveforms in separate zones.

Select "ON" in the zone usage. Then, selecting the display settings in the setting menu screen and selecting the channel parameters, the following screen with the zone added is displayed.

| CH.  |         | Display scale |       | Color       | Zone | Posi |
|------|---------|---------------|-------|-------------|------|------|
| Type | Minimum | Maximum       |       |             |      |      |
| 01   | Std.    | -10.00        | 10.00 | Red         | 1    | 1    |
| 02   | Std.    | -10.00        | 10.00 | Blue        | 2    | 1    |
| 03   | Std.    | -10.00        | 10.00 | Green       | 1    | 1    |
| 04   | Std.    | -10.00        | 10.00 | Brown       | 2    | 1    |
| 05   | Std.    | -10.00        | 10.00 | Purple      | 1    | 1    |
| 06   | Std.    | -10.00        | 10.00 | Orange      | 2    | 1    |
| 07   | Std.    | -10.00        | 10.00 | Grey        | 1    | 1    |
| 08   | Std.    | -10.00        | 10.00 | Cyan        | 2    | 1    |
| 09   | Std.    | -10.00        | 10.00 | Light Green | 1    | 1    |
| 10   | Std.    | -10.00        | 10.00 | Yellow      | 2    | 1    |
| 11   | Std.    | -10.00        | 10.00 | Pink        | 1    | 1    |
| 12   | Std.    | -10.00        | 10.00 | Dark Blue   | 2    | 1    |
| 13   | Std.    | -10.00        | 10.00 | Red         | 1    | 1    |

When the zone is set to either 1 or 2, the display of wave format in the trend screen is divided into 2. Channels set by 1 are displayed in Zone 1 and channels set by 2 are displayed in Zone 2.

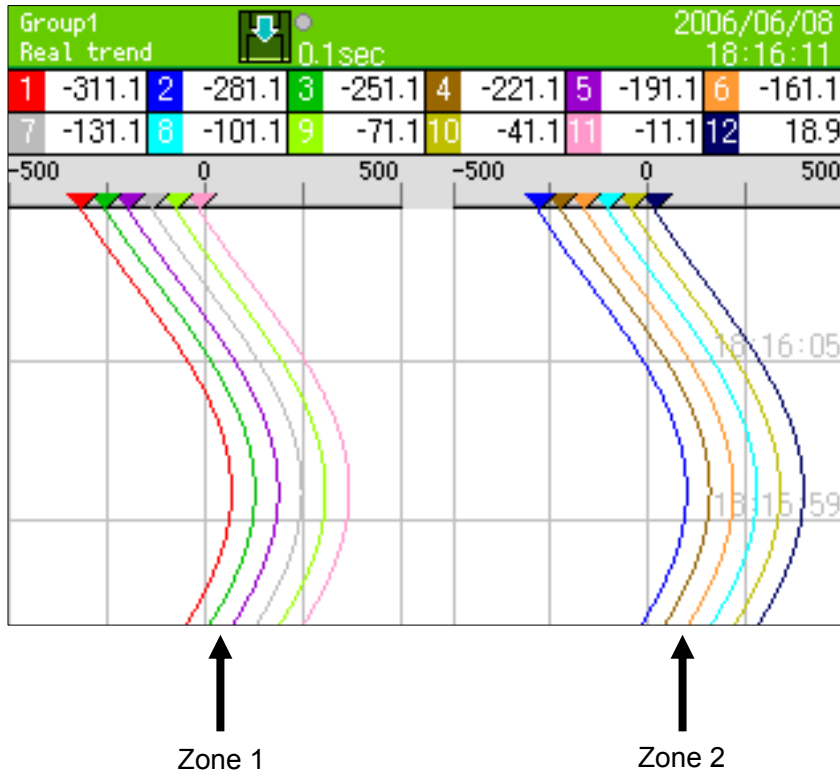

### 13.3.5 LCD settings

- Proceed from the MENU settings.
- Move the focus to the setting item using direction key.
- By pressing the ENTER key on the item for setting, the screen moves to the input screen.

By selecting the display settings on the setting menu screen and then selecting the LCD settings, the following screen is displayed.



#### ■ Setting the display off timer (minute)

- The display-off timer for the LCD can be set from 1 to 60 minutes.
- For canceling the display off, tap any key.

#### ■ Setting the display brightness

- Select the brightness of the LCD backlight from 4 steps. 1 is the brightest and 4 is the darkest.

#### ■ Setting the back color

- Select the back color of the screen from white or black.

## 13.4 Alarm settings

- Proceed from the MENU settings.
- Move the focus to the setting item using direction key.
- By pressing the ENTER key on the item for setting, the screen moves to the input screen.

By selecting the alarm settings on the setting menu screen, the following screen is displayed.

| No. | Type | Value | Ref. CH | Deadband | Delay |
|-----|------|-------|---------|----------|-------|
| AL1 | None | 0.0   | 01      | 0.0      | 0     |
| AL2 | None | 0.0   | 01      | 0.0      | 0     |
| AL3 | None | 0.0   | 01      | 0.0      | 0     |
| AL4 | None | 0.0   | 01      | 0.0      | 0     |

| No. | Relay | AND/OR | MARKER |
|-----|-------|--------|--------|
| AL1 | 0     | OR     | 0      |
| AL2 | 0     | OR     | 0      |
| AL3 | 0     | OR     | 0      |
| AL4 | 0     | OR     | 0      |

### ■ Setting the type

- Set the alarm type.

|       |                           |             |  |
|-------|---------------------------|-------------|--|
| None  | The alarm is not set      | Diff. upper | Set the differential upper limit alarm |
| Upper | Set the upper limit alarm | Diff. lower | Set the differential lower limit alarm |
| Lower | Set the lower limit       | Error       | Set the error alarm                    |

### ■ Setting the settings value

- Set the judgment value of alarm.

### ■ Setting the reference CH

- Set the reference channel for the differential high limit alarm/differential low limit alarm.

### ■ Setting the dead band

- Set the alarm deadband between the alarm value and its release. (Refer to the next page.)

### ■ Setting the delay

- Set the delay time for the alarm.(0-3600 seconds)

### ■ Setting the relay

\* The alarm output terminal (option) is necessary for outputting alarms actually.

- The relays can be set regardless of whether the alarm output terminal is used.
- Set the relays with the alarm output terminal number 0 to 12. When 0 is set, the alarm is not outputted.

### ■ Setting the alarm output mode

|     |  |
|-----|--|
| AND | The relay becomes ON when all alarms set in one alarm output terminal are activated.   |
| OR  | The relay becomes ON when any of alarms set in one alarm output terminal is activated. |

When both of "AND" and "OR" are set to one relay channel, the relay becomes ON when either of "AND" of all alarms set with "AND" or all "OR" of alarms set with "OR" is established.

■ Setting the maker

- Set the automatically written maker on the trend for alarm activation. When 0 is set, the maker is not written.

Differential alarm

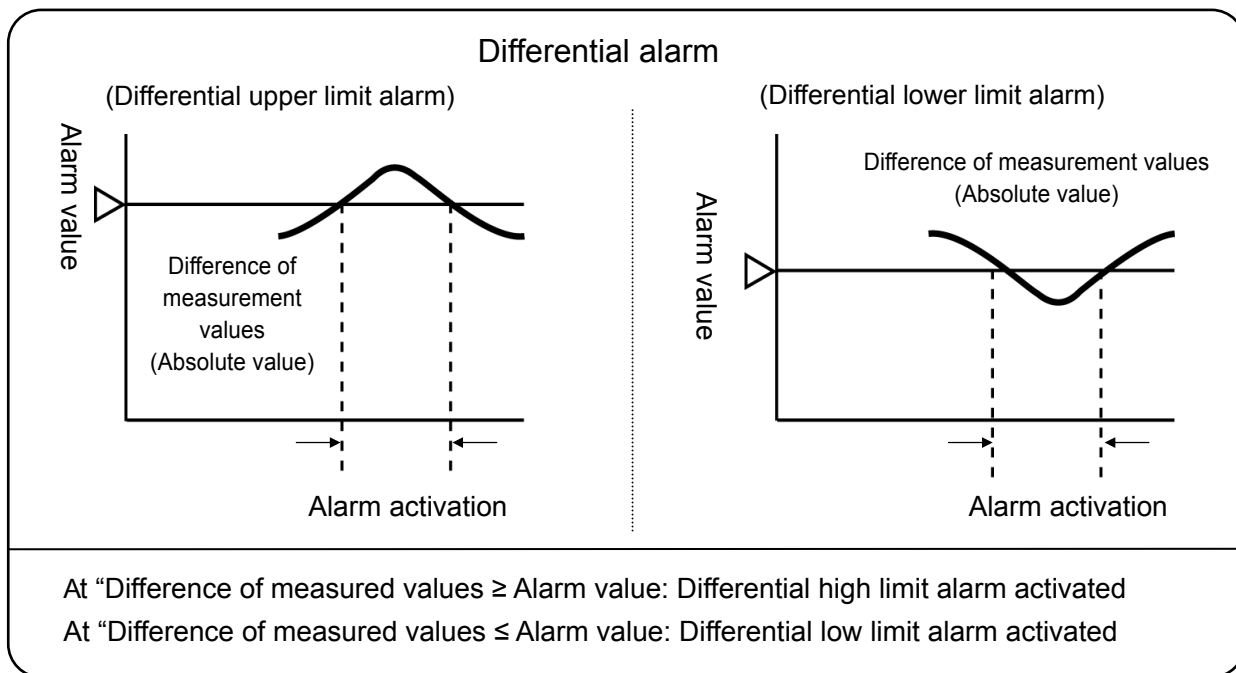

Alarm dead band

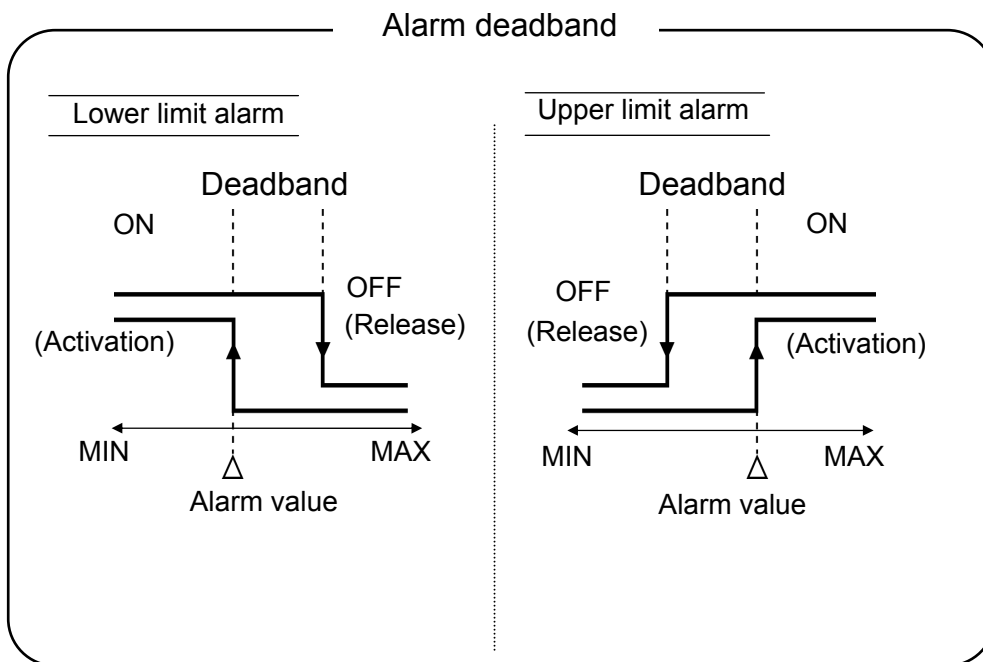

## 13.5 File settings

- Proceed from the MENU settings.
- Move the focus to the setting item using direction key.
- By pressing the ENTER key on the item for setting, the screen moves to the input screen.

By selecting the file settings on the setting menu screen, the following screen is displayed.

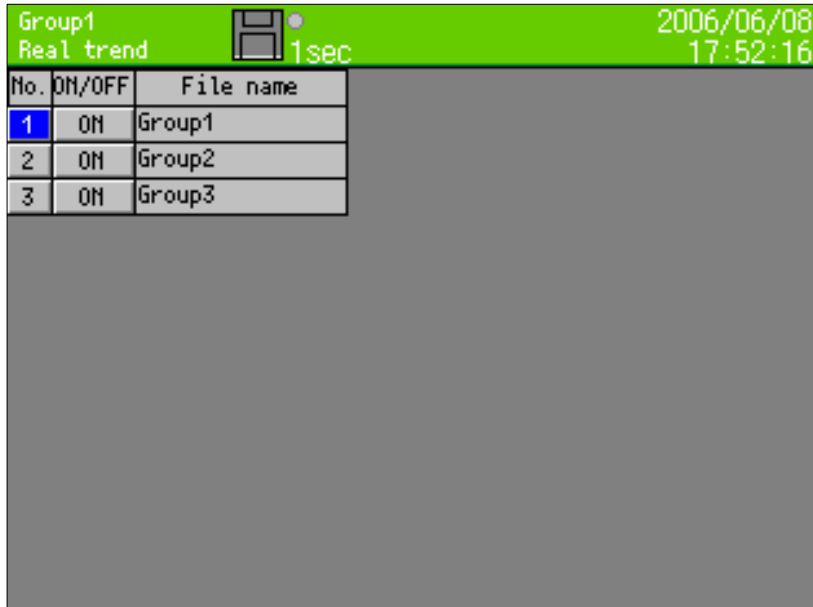

| No. | ON/OFF | File name |
|-----|--------|-----------|
| 1   | ON     | Group1    |
| 2   | ON     | Group2    |
| 3   | ON     | Group3    |

### ■ No.

By selecting number and pressing the ENTER key, the file setting screen of the selected group is displayed. Detail of the setting method is explained on the next page.

### ■ ON/OFF

When ON is displayed, data is recorded, and when OFF is displayed, data is not recorded.



<File setting screen>

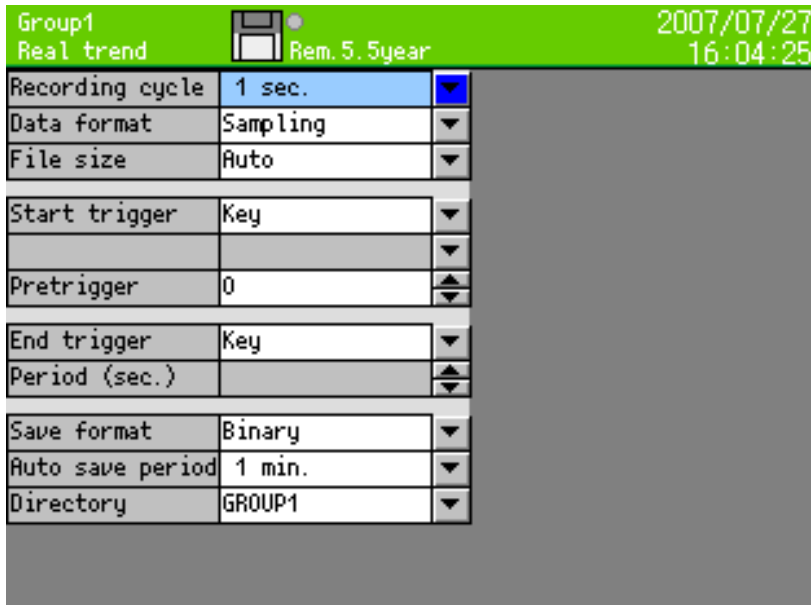

■ Setting the recording cycle \*\*

|         |   |
|---------|---|
| Seconds | 0.1 sec, 0.2 sec, 0.5 sec, 1 sec, 2 sec, 3 sec, 5 sec, 10 sec, 15 sec, 20 sec, 30 sec |
| Minutes | 1 min, 2 min, 3 min, 5 min, 10 min, 15 min, 20 min, 30 min, 60 min                    |

- \* If the recording cycle less than 0.5 seconds is set, recording is done in 3 groups and 12 points for each group.
- \* When interval is set less than 0.5 seconds (0.1-0.5 seconds) at the KR2161/2121, input channel numbers become automatically 4 points.

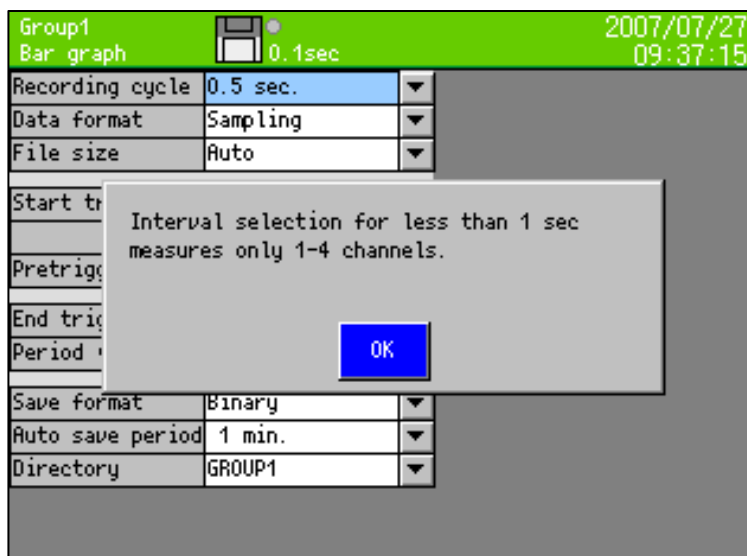

■ Setting the data format

When the recording cycle is 0.1 seconds, the sampling is only selectable.

In recording the data into the file, the average, maximum, minimum or maximum/minimum values in the period of the recording cycle can be recorded. When the maximum/minimum is selected, the data size becomes 1.5 times larger.

|          |         |         |         |                 |
|----------|---------|---------|---------|-----------------|
| Sampling | Average | Maximum | Minimum | Maximum/minimum |
|----------|---------|---------|---------|-----------------|

■ **Setting the file size**

Select the file size (period). When the file reaches specified size, the file is completed, and the data after completed is recorded by another name.

Pause of [minute] and [hour] is calculated based on 0:00, pause of 1 week is calculated based on 0:00 of Sunday, and pause of 1 month is calculated based on 0:00 of first day.

|        |   |
|--------|---|
| Minute | 10 minutes, 15 minutes, 20 minutes, 30 minutes, 60 minutes      |
| Hour   | 2 hours, 3 hours, 4 hours, 6 hours, 8 hours, 12 hours, 24 hours |
| Other  | 1 week, 1 month   |

When recording is stopped before reaching the file size, or the data reaches maximum file size (refer to 9.9 Internal memory), file is completed.

■ **Setting the start trigger**

The recording starts by the following trigger.

|     |       |                        |
|-----|-------|------------------------|
| Key | Alarm | Digital input (option) |
|-----|-------|------------------------|

| Trigger type           | Contents   |
|------------------------|--|
| Key                    | The recording starts without any conditions.   |
| Alarm                  | The recording starts when the alarm relay becomes ON.<br>When this item is selected, the relay terminal number can be selected.            |
| Digital input (option) | The recording starts when the digital input terminal becomes ON.<br>When this item is selected, the input terminal number can be selected. |

■ **Setting the pretrigger (0 to 950)**

When the recording starts, the past data retroactive to the count set here are recorded.

Example: When the recording starts at 13:00:00 with the pretrigger “10” and the recording cycle “2 seconds”, the data from 12:59:40 to 12:59:58 are added to the beginning of the file.

Note: When the power is turned off or the settings are changed, the data for the pretrigger are cleared, and the data in the interval specified here may not be enough. In this case, only the data being saved are added to the beginning of the file.

■ **Setting the end trigger**

Select the condition for the end of recording. The same contents as the start trigger are displayed in the first item.

|             |                  |
|-------------|------------------|
| Key (Alarm) | Period (seconds) |
|-------------|------------------|

| Trigger type | Contents  |
|--------------|---|
| Key (Alarm)  | The recording stops when the start conditions are not established.  |
| Period       | After recording the data for the specified period (seconds), the recording stops. At the time, if the start trigger conditions are established, the recording starts again immediately (within 1 second). |

■ **Setting the period (seconds) (0 to 30000)**

After starting record by start trigger, if trigger becomes OFF, the data is recorded for set period and then stopped. However, when recording is stopped by STOP key, recording is stopped despite of this setting.

■ **Setting the file size**

Select the file size (period). When the file reaches specified size, the file is completed, and the data after completed is recorded by another name.

Pause of [minute] and [hour] is calculated based on 0:00, pause of 1 week is calculated based on 0:00 of Sunday, and pause of 1 month is calculated based on 0:00 of first day.

|        |   |
|--------|---|
| Minute | 10 minutes, 15 minutes, 20 minutes, 30 minutes, 60 minutes      |
| Hour   | 2 hours, 3 hours, 4 hours, 6 hours, 8 hours, 12 hours, 24 hours |
| Other  | 1 week, 1 month   |

When recording is stopped before reaching the file size, or the data reaches maximum file size (refer to 9.9 Internal memory), file is completed.

■ **Setting the save format**

Select the file format for recording the data into a CF card.

|        |     |                      |
|--------|-----|----------------------|
| Binary | CSV | CSV<br>(continuance) |
|--------|-----|----------------------|

| Save format          | Contents  |
|----------------------|---|
| Binary               | The data are recorded with the binary file (extension "krf"). For the replay, this recorder or analytical software is necessary.  |
| CSV                  | The data are recorded with the CSV formatted text file. The data can be read with spreadsheet application software like Excel (Microsoft), etc. In addition, the data can be used in the attached report application software. When the decimal marker is set to ",", the data becomes the tab-delimited text file with the extension of "txt". |
| CSV<br>(continuance) | The format is same as the above, however when recording is stopped by trigger, the data is recorded same file continuously after restarting. In above case, when recording is stopped, the file is completed, and the data is recorded by new file after restarting.  |

■ **Setting the auto save period**

This is the interval for coping the file in the internal memory to an external memory.

In addition to this interval, each file is copied to the CF card at its completion. (Refer to Para. 9.9.)

|         |   |
|---------|---|
| Minutes | No settings, 1 min, 2 min, 3 min, 5 min, 10 min, 20 min, 30 min, 60 min |
|---------|---|

■ **Setting the directory (Maximum length 16 characters)**

- For saving the data to an external storage media, the directory name for saving can be set.
- The hierarchy can also be specified. The delimiting symbol is "\ " (backslash). Refer to "Para. 7.3 Character entering method".

## 13.6 Totalizer reset settings

The totalizer is executed by the calculation settings of each channel. On this screen, set the procedure for resetting the totalized data to 0.

All calculations are reset in this setting except ITG24. ITG24 is reset only in base time and not reset every interval.

- Proceed from the MENU settings.
- Move the focus to the setting item using direction key.
- By pressing the ENTER key on the item for setting, the screen moves to the input screen.

By selecting the totalizer reset settings on the setting menu screen, the following screen is displayed.

|                |              |      |            |          |
|----------------|--------------|------|------------|----------|
| Group1         | Real trend   | 1sec | 2008/04/01 | 10:09:02 |
| Setting method | All channels |      |            |          |
| CH             | All          |      |            |          |
| Manual reset   | Execute      |      |            |          |
| Auto Reset     | OFF          |      |            |          |
| Base time      | 00:00        |      |            |          |
| Interval       | 24:00        |      |            |          |
| Reset by DI    | None         |      |            |          |

### ■ Setting method

- Select 'all channels' or 'individual channel'.

In case of 'all channels', setting contents are accommodated all channels.

In case of 'individual channel', individual reset setting is accommodated each channel.

### ■ CH

- When select 'individual channel', setting is performed to specified channel.

### ■ Manual reset

- The totalized data is reset to 0 manually.

### ■ Auto reset

- When the auto reset of totalizer is used, set it to ON.  
Set it to OFF when it is not used.

### ■ Base time and interval

- The totalizer reset is executed at the following time,  
 $\text{Base time} + (\text{interval} \times n) \quad n = 0, 1, 2, 3, \dots$

Example: When the base time is set at 0:00 and the interval is set at 04:00, the totalized value is reset at 0 o'clock, 4 o'clock, 8 o'clock, 12 o'clock, 16 o'clock and 20 o'clock.

### ■ Reset by digital input (option)

\*When this instrument has not digital input option, this item is not displayed.

- The totalizer rest is executed when the specified digital input terminal becomes ON.  
Select "None" when it is not used.

## 13.7 Schedule settings

- Proceed from the MENU settings.
- Move the focus to the setting item using direction key.
- By pressing the ENTER key on the item for setting, the screen moves to the input screen.

By selecting the schedule settings on the setting menu screen, the following screen is displayed.

| Date settings       |          | Date |       | Time |  |
|---------------------|----------|------|-------|------|--|
| Start date and time | 05/01/01 | ▼    | 00:00 | ▼    |  |
| End date and time   | 05/01/02 | ▼    | 00:00 | ▼    |  |

| Day setting | Sun                      | Mon                      | Tue                      | Wed                      | Thu                      | Fri                      | Sat                      |
|-------------|--------------------------|--------------------------|--------------------------|--------------------------|--------------------------|--------------------------|--------------------------|
| Usage days  | <input type="checkbox"/> | <input type="checkbox"/> | <input type="checkbox"/> | <input type="checkbox"/> | <input type="checkbox"/> | <input type="checkbox"/> | <input type="checkbox"/> |
| Start time  | 00:00                    |                          | ▼                        |                          |                          |                          |                          |
| End time    | 00:00                    |                          | ▼                        |                          |                          |                          |                          |

When the schedule is set on this screen, the recording is executed for its set period only. Even though the conditions specified with the file settings are established, the recording cannot be executed if it is not in the scheduled period. The status bar is displayed in gray for out-of-scheduled period.

### ■ Setting the schedule

- Select it from No settings, date or day.
- By these settings, the following settings become enabled.

### ■ Setting the parameters for the date settings

- Set the start date/time and the end date/time.

### ■ Setting the parameters for the day setting

- Check the day for using.
- Set the start time and the end time.

## 13.8 Marker text setting

- Proceed from the MENU settings.
- Move the focus to the setting item using direction key.
- By pressing the ENTER key on the item for setting, the screen moves to the input screen.

By selecting the marker text settings on the setting menu screen, the following screen is displayed.

| Without digital input option                                |       | With digital input option                             |          |
|---|-------|---|----------|
| Group1<br>Real trend Rem. 1.4year<br>2006/07/14<br>11:40:29 |       | Group1<br>Real trend 0.2sec<br>2006/08/09<br>18:33:24 |          |
| No.   | Clear | No.   | DI Group |
| Marker text   |       | Marker text   |          |
| 1   | Clear | 1   | None 1   |
| 2   | Clear | 2   | None 1   |
| 3   | Clear | 3   | None 1   |
| 4   | Clear | 4   | None 1   |
| 5   | Clear | 5   | None 1   |
| 6   | Clear | 6   | None 1   |
| 7   | Clear | 7   | None 1   |
| 8   | Clear | 8   | None 1   |
| 9   | Clear | 9   | None 1   |
| 10  | Clear | 10  | None 1   |
| 11  | Clear | 11  | None 1   |
| 12  | Clear | 12  | None 1   |
| 13  | Clear |   |          |
| 14  | Clear |   |          |

On this screen, up to 50 marker texts (max. 30 characters) to be written on the trends can be registered in advance. For writing the marker text, refer to Para. 9.3.

Even when texts are not registered on this screen, texts can be created at the writing of markers.

- By selecting the "Clear", the marker text is erased.
- By selecting the message column, the character entering screen is displayed.

(Maker writing with the digital input (option))

The maker can be written on the trends with ON from the digital input terminal.

<Digital input --- Standard>

When the input terminal designated for the [digital input] becomes ON, the corresponded maker is written on the trends of the specified group.

<Digital input --- Binary>

Set the maker text number 1 to 50 by using the digital input terminal 1 to 7 (Binary expression of low bit at terminal 1 side and high bit at terminal 7 side).

When terminal 8 is turned on under condition of the contact status of 1 to 50 at the terminal 1 to 7, the markers corresponding to the marker text numbers are written on the trends of the specified group.

## 13.9 Memory operation

- Proceed from the MENU settings.
- Move the focus to the setting item using direction key.
- By pressing the ENTER key on the item for setting, the screen moves to the input screen.

Following screen is displayed when, memory operation of settings menu screen is selected.

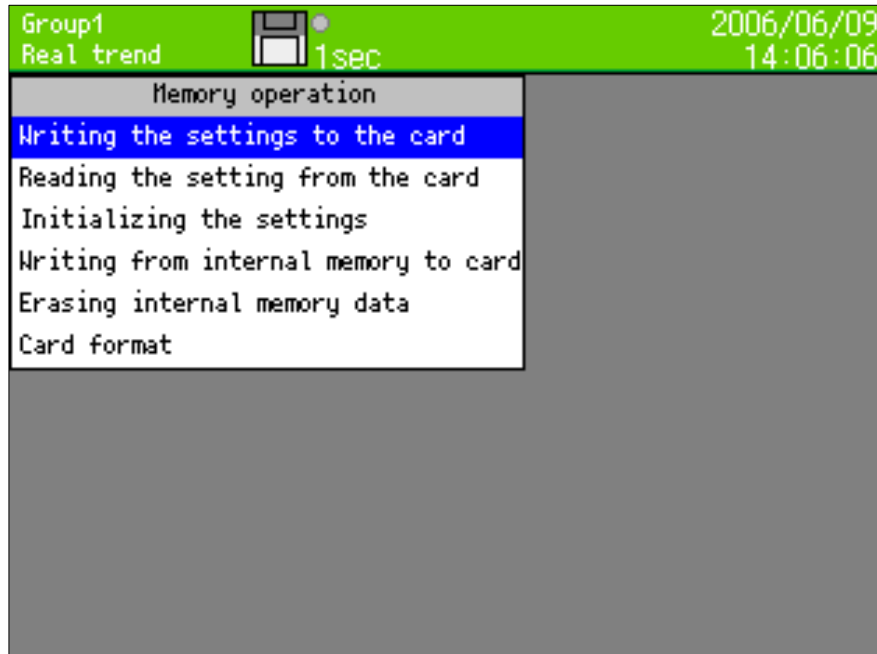

### ■ Writing the settings to the card

Up to 10 current setting contents can be written to CF card.

Numbers 1-10 and file name is displayed as list. Select the number to be written and press the ENTER key.

On pressing the “ENTER” key after entering the file name, setting contents are written.

File is saved with extension “.krs”, in “SETUP” folder in the CF card.

Settings file can be read and used in other KR2000 series also.

### ■ Reading the settings from card

Settings file is read from CF card and the current settings are overwritten.

Numbers 1-10 and file name is displayed as list. Select the number to be read and press the ENTER key.

### ■ Initializing the settings

As the current settings are the settings at the time of shipping from the factory they are overwritten.

### ■ Writing the internal memory to card

Entire data from the internal memory is written to the CF card.

### ■ Erasing internal memory data

Entire data of internal memory is erased.

### ■ Card format

CF card is quick formatted.

## 13.10 Network settings

### 13.10.1 Ethernet settings

- Proceed from the MENU settings.
- Move the focus to the setting item using direction key.
- By pressing the ENTER key on the item for setting, the screen moves to the input screen.

By selecting the network settings on the setting menu screen and then selecting the Ethernet settings, the following screen is displayed.

| Group1          |                 | Real trend |  | 2006/06/09 |  |
|-----------------|-----------------|------------|--|------------|--|
|                 |                 | 1sec       |  | 09:56:56   |  |
| IP address      | 192.168.254.254 |            |  | ▼          |  |
| Subnet mask     | 255.255.255.0   |            |  | ▼          |  |
| Default gateway | 0.0.0.0         |            |  | ▼          |  |

Set IP address, etc. for using this recorder on the Ethernet.

#### ■ IP address

Set IP address of this recorder. The DHCP (automatic assignment of IP addresses) cannot be used. Ask the IP address to the administrator for the network to connect.

#### ■ Subnet mask

Set the subnet mask of this recorder.

#### ■ Default gateway

If there is router gateway like a router, etc. on the network, set default gateway address.

### Example of usage in small scale network

When this recorder is used in a small network without connecting to an interoffice LAN or Internet via a router, set the IP address as follows.

| Instrument | IP address      | Subnet mask   |
|------------|-----------------|---------------|
| KR2000 A   | 192.168.254.254 | 255.255.255.0 |
| KR2000 B   | 192.168.254.253 | 255.255.255.0 |
| ...        | ...             | ...           |
| PC A       | 192.168.254.1   | 255.255.255.0 |
| PC B       | 192.168.254.2   | 255.255.255.0 |
| ...        | ...             | ...           |



### 13.10.2 DNS settings

The DNS server is for converting the address specified with a name into the IP address. When the addresses of the FTP server, POP3 server, SMTP server, etc. are entered with names, make sure to set the DNS server.

- Proceed from the MENU settings.
- Move the focus to the setting item using direction key.
- By pressing the ENTER key on the item for setting, the screen moves to the input screen.

By selecting the network settings on the setting menu screen and then selecting the DNS settings, the following screen is displayed.

|                     |            |            |
|---------------------|------------|------------|
| Group1              |            | 2006/06/09 |
| Real trend          |            | 10:46:48   |
| 1sec                |            |            |
| DNS ON/OFF          | OFF        |            |
| Primary server IP   | 0. 0. 0. 0 | ▼          |
| Secondary server IP | 0. 0. 0. 0 | ▼          |

#### ■ DNS on/off

- Select the DNS from ON (enabled) or OFF (disabled).

#### ■ Primary server IP, secondary server IP

- Enter the address of the DNS server. If the primary server is not found, use the address of the secondary server. When there is only one DNS server, it is no problem not to enter any address to the secondary server.

### 13.10.3 Web server settings

Set the login user name and password for accessing web server.

- Proceed from the MENU settings.
- Move the focus to the setting item using direction key.
- By pressing the ENTER key on the item for setting, the screen moves to the input screen.

By selecting the network settings on the setting menu screen and then selecting the Web server settings, the following screen is displayed.

| Administrator user |      |
|--------------------|------|
| Login user name    | user |
| Login password     |      |

| General user    |       |
|-----------------|-------|
| Login user name | guest |
| Login password  |       |

Select 'Administrator user' or 'General user'.

|                    |   |
|--------------------|---|
| Administrator user | All items are operated.   |
| General user       | Recorder display and data display are operated. Only the screen update is operated on the recorder display. |

#### ■ Login user name

- Set the login user name of administrator user/general user.

#### ■ Login password

- Set the login password of administrator user/general user.

### 13.10.4 FTP client settings

- Proceed from the MENU settings.
- Move the focus to the setting item using direction key.
- By pressing the ENTER key on the item for setting, the screen moves to the input screen.

By selecting the network settings on the setting menu screen and then selecting the FTP client settings, the following screen is displayed.

| Group1          |     | 2008/04/01 |
|-----------------|-----|------------|
| Real trend      |     | 10:09:44   |
| Server address  |     | ▼          |
| Directory       |     | ▼          |
| Login user name |     | ▼          |
| Login password  |     | ▼          |
| PASV mode       | OFF |            |
| Auto Forwarding | OFF |            |
| Retry mode      | OFF |            |

Execute the settings for using the FTP client function of this recorder.

#### ■ Server address

Specify the address of the server for transferring the file. When the address is set with a name (○○.co.jp, ○○.com, etc.), not the IP address, make sure to set the DNS (13.10.2).

#### ■ Directory

Set the directory for writing the file. If there is no directory, the automatic creation cannot be executed.

#### ■ Login user name

Set the user name for logging into the FTP server.

#### ■ Login password

Set the password for logging into the FTP server.

#### ■ PASV mode

Set to ON when the file is transferred with the PASV mode.

#### ■ Auto Forwarding

Set to ON for transferring the file created automatically at the switching of the file for recording.

#### ■ Retry mode

When FTP transfer is failed three times on 'OFF', error message is displayed on the screen and stop transfer. When retry mode is 'ON', try to transfer until succeeding. However, when transfer-waiting files become over 360, files after 360 are not transferred. When turns off the power of the instrument, transfer-waiting files are not transferred after tuning on the power.

### 13.10.5 FTP server settings

- Proceed from the MENU settings.
- Move the focus to the setting item using direction key.
- By pressing the ENTER key on the item for setting, the screen moves to the input screen.

By selecting the network settings on the setting menu screen and then selecting the FTP server settings, the following screen is displayed.

|                   |            |      |            |
|-------------------|------------|------|------------|
| Group1            | Real trend | 1sec | 2006/06/09 |
| FTP server ON/OFF | OFF        |      | 09:58:14   |
| Login user name   | anonymous  |      |            |
| Login password    |            |      |            |

Execute the settings for using the FTP client function of this recorder.

■ FTP server ON/OFF

When the FTP server is set to ON, the FTP server function is executed. Set it OFF when FTP server function is not in use.

■ Login user name

Set the user name for logging in to the FTP server.

■ Login password

Set the password for logging in to FTP server.

### Using method of FTP server

By using the function of the FTP server, the file in the CF card of this recorder can be read from a PC on the network. The followings are the connection method for using a Web browser (Internet Explorer, Netscape, Opera).

Note: In case of connecting to the FTP server by using the Web browser, if a user name other than "anonymous" is set, the normal connection may not be possible.

- (1) Enter "ftp://(IP address of this instrument)/ " into the address bar in the browser and press the ENTER key of the PC
- (2) The list of files and folders is displayed in the browser.
- (3) From then, like the Windows explorer, file operations of moving, copying, opening, etc. can be executed. However, writing to this recorder is not permitted.

For the connection using a FTP client software other than the Web browser, set the software to log in by the user name and password set with this recorder and execute the connection.

### 13.10.6 SNTP settings

- Proceed from the MENU settings.
- Move the focus to the setting item using direction key.
- By pressing the ENTER key on the item for setting, the screen moves to the input screen.

By selecting the network settings on the setting menu screen and then selecting the SNTP settings, the following screen is displayed.

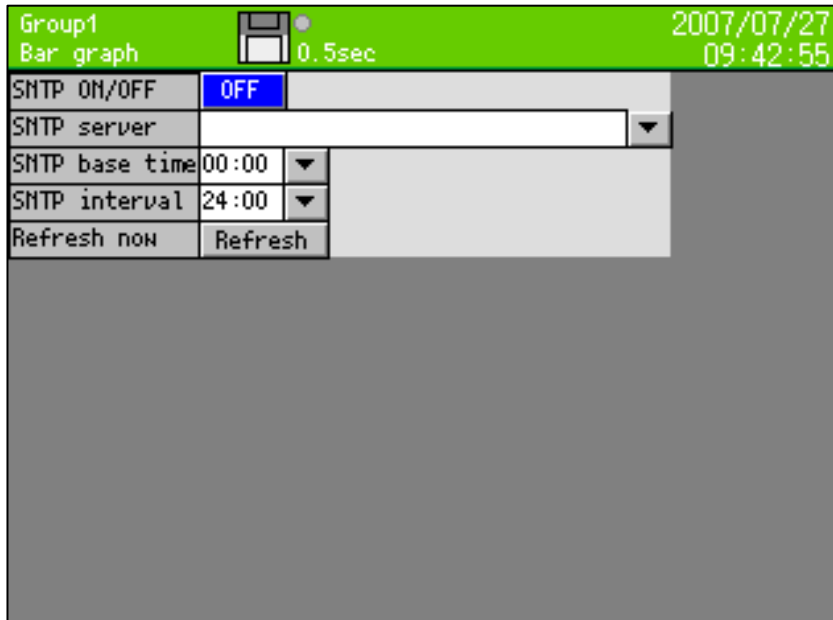

Execute the settings for using the SNTP function of this recorder.

■ SNTP ON/OFF

Set to “ON” when the automatic time synchronization by the SNTP is executed. If not executed, set to “OFF”.

■ SNTP server

Specify the address of the SNTP server. When the address is set with a name (○○.co.jp, ○○.com, etc.), not the IP address, make sure to set the DNS (13.10.2).

■ SNTP base time/ SNTP interval

- The time synchronization is executed at the following time.  
base time + (interval x n) n = 0, 1, 2, 3, ...

Example: In case that the “SNTP base time” is 0:00 and the “SNTP interval” is 04:00, the time synchronization by the SNTP is executed at 0 o'clock, 4 o'clock, 8 o'clock, 12 o'clock, 16 o'clock and 20 o'clock.

■ Refresh now

When the “Refresh” button is tapped, the time synchronization with the SNTP server is executed.

Example of SNTP sever

- |  |  |
|--|--|
| • 131.107.1.10.....NIST  | • 130.34.48.32.....Tohoku University   |
| • 198.123.30.132..NASA   | • 157.16.213.52...Osaka Prefecture University  |
| • 133.100.9.2.....Fukuoka University   | • 133.41.4.1.....Hiroshima University  |
| • 133.100.11.8.....Fukuoka University  | • 210.173.160.57..National Institute of Information and Communications Technology (NiCT) |
| • 133.40.41.175....National Astronomical Observatory (Mizusawa VERA Observatory) | • 210.173.160.87..National Institute of Information and Communications Technology (NiCT) |
| • 130.69.251.23...The University of Tokyo  |  |

### 13.10.7 E-MAIL settings

This recorder can send e-mails by the event of alarm or time.

Specify 8 forwarding addresses in advance. E-mails are sent to the addresses selected from them when the event (Maximum 8 conditions can be registered) is activated.

- Proceed from the MENU settings.
- Move the focus to the setting item using direction key.
- By pressing the ENTER key on the item for setting, the screen moves to the input screen.

By selecting the network settings on the setting menu screen and then selecting the E-MAIL settings, the following screen is displayed.

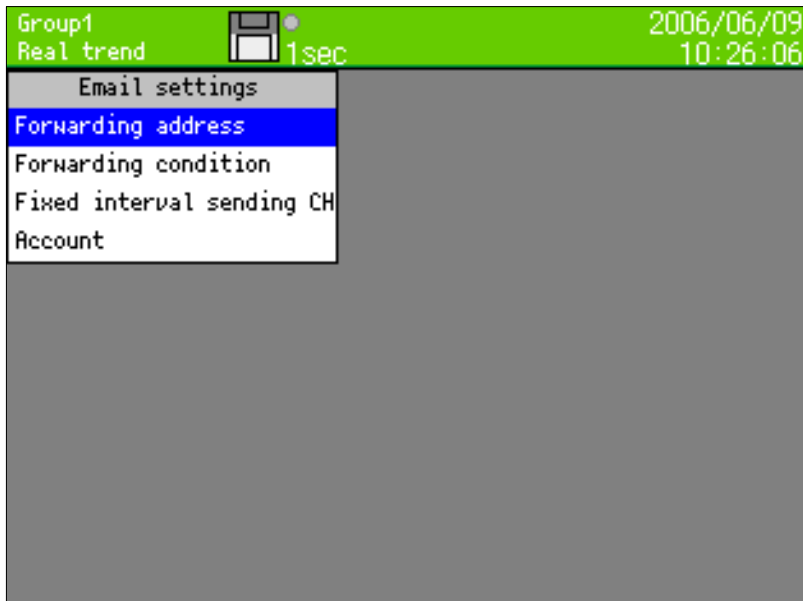

By selecting the forwarding address, the following screen is displayed. (For the settings of the forwarding address name, refer to “7.3 Character entering method.”)

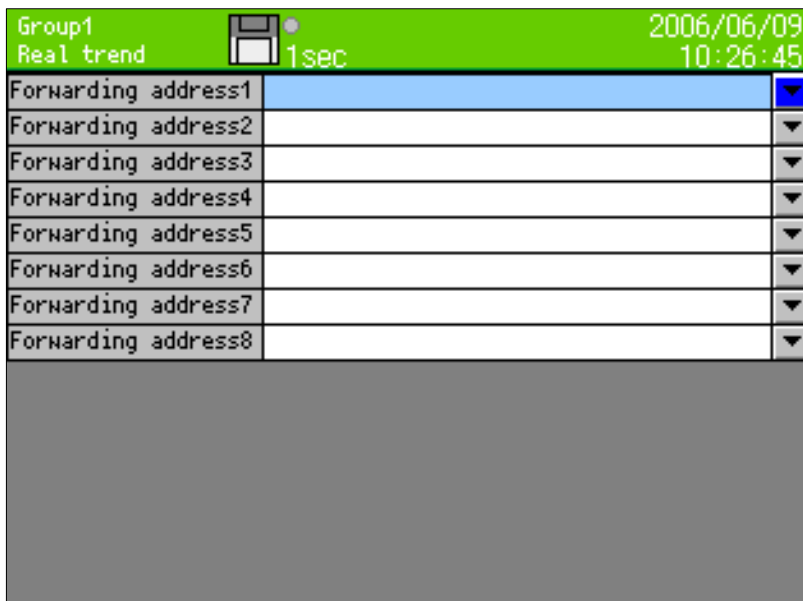

Set the forwarding address.

- Up to 8 forwarding addresses can be set.

By selecting the forwarding condition, the following screen is displayed.

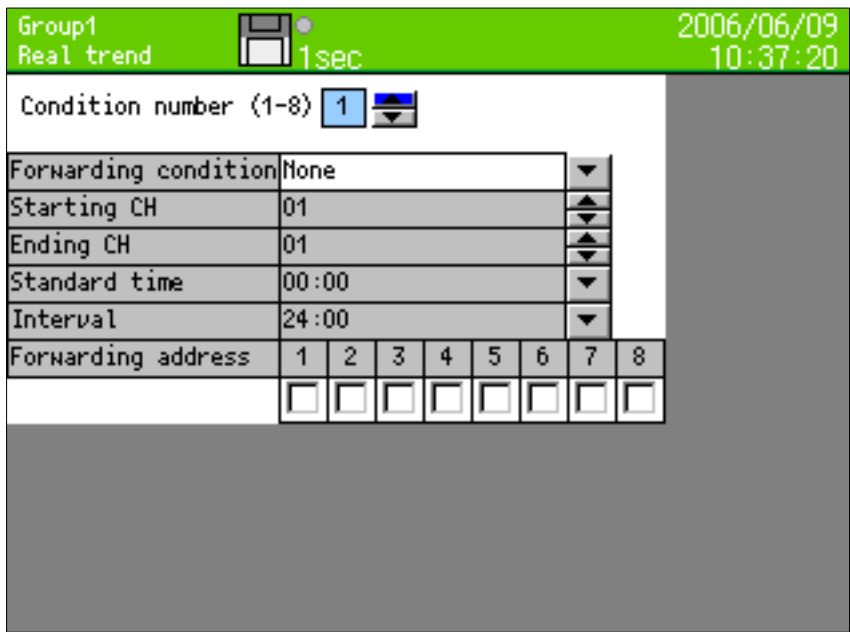

■ Selecting the condition number

- Up to 8 types of the e-mail forwarding condition can be registered. On this screen, set conditions for the number selected here.

■ Selecting forwarding condition

- Set the condition for forwarding the e-mail to the forwarding addresses.

| Item                  | Contents  |
|-----------------------|---|
| None                  | This condition is not used  |
| Alarm activation time | The e-mail is forwarded when the alarm is activated at the specified channel. |
| Fixed interval        | The e-mail is forwarded at every interval time based on the base time.        |

■ Starting CH, Ending CH

- These settings are effective then the "Alarm activated time" is selected in the forwarding condition. The e-mail is forwarded when the alarm is activated in the channels specified by the starting channel and the ending channel.

■ Standard time, interval

- These settings are effective then the "Fixed interval" is selected in the forwarding condition. The e-mail is forwarded at the following time.  
Base time + (interval x n) n = 0, 1, 2, 3, ... .

Example: In case that the "Standard time" is 0:00, "Interval" is 04:00, the e-mail is forwarded at 0 o'clock, 4 o'clock, 8 o'clock, 12 o'clock, 16 o'clock and 20 o'clock.

■ Forwarding address

- Check the address for forwarding.

By selecting the “Fixed interval sending CH”, the following screen is displayed.  
 When the “Fixed interval” is specified for the forwarding condition, the e-mail is forwarded by writing the data of the channels, which are registered on this screen, into the message body.

Group1  
 Real trend 0.1sec 2006/06/09 09:33:37

Condition number (1-8) 1

|                          |                          |                          |                          |                          |                          |                          |                          |                          |                          |                          |                          |
|--------------------------|--------------------------|--------------------------|--------------------------|--------------------------|--------------------------|--------------------------|--------------------------|--------------------------|--------------------------|--------------------------|--------------------------|
| 01                       | 02                       | 03                       | 04                       | 05                       | 06                       | 07                       | 08                       | 09                       | 10                       | 11                       | 12                       |
| <input type="checkbox"/> | <input type="checkbox"/> | <input type="checkbox"/> | <input type="checkbox"/> | <input type="checkbox"/> | <input type="checkbox"/> | <input type="checkbox"/> | <input type="checkbox"/> | <input type="checkbox"/> | <input type="checkbox"/> | <input type="checkbox"/> | <input type="checkbox"/> |
| 13                       | 14                       | 15                       | 16                       | 17                       | 18                       | 19                       | 20                       | 21                       | 22                       | 23                       | 24                       |
| <input type="checkbox"/> | <input type="checkbox"/> | <input type="checkbox"/> | <input type="checkbox"/> | <input type="checkbox"/> | <input type="checkbox"/> | <input type="checkbox"/> | <input type="checkbox"/> | <input type="checkbox"/> | <input type="checkbox"/> | <input type="checkbox"/> | <input type="checkbox"/> |
| 25                       | 26                       | 27                       | 28                       | 29                       | 30                       | 31                       | 32                       | 33                       | 34                       | 35                       | 36                       |
| <input type="checkbox"/> | <input type="checkbox"/> | <input type="checkbox"/> | <input type="checkbox"/> | <input type="checkbox"/> | <input type="checkbox"/> | <input type="checkbox"/> | <input type="checkbox"/> | <input type="checkbox"/> | <input type="checkbox"/> | <input type="checkbox"/> | <input type="checkbox"/> |
| 37                       | 38                       | 39                       | 40                       | 41                       | 42                       | 43                       | 44                       |                          |                          |                          |                          |
| <input type="checkbox"/> | <input type="checkbox"/> | <input type="checkbox"/> | <input type="checkbox"/> | <input type="checkbox"/> | <input type="checkbox"/> | <input type="checkbox"/> | <input type="checkbox"/> |                          |                          |                          |                          |

- Condition number
  - Select the e-mail forwarding condition number for the settings.
- Setting fixed interval forwarding CH data
  - Check the channel numbers for attaching the data.



By selecting the "Account", the following screen is displayed.

| Group1           |        | 2007/07/27 |
|------------------|--------|------------|
| Bar graph        | 0.5sec | 09:43:44   |
| POP3 address     |        | ▼          |
| SMTP address     |        | ▼          |
| Sender address   |        | ▼          |
| Account          |        | ▼          |
| Password         |        | ▼          |
| SMTP port number | 25     | ▼          |
| POP3 port number | 110    | ▼          |

- POP3 address
  - This address is used when the SMTP server requires the POP3 authentication. Enter the address of the POP3 server. Do not enter anything when POP3 authentication is not required.
- SMTP address
  - Enter the address of the SMTP server.
- Sender address
  - Enter the e-mail address obtained for this recorder. When this address is not correct, some SMTP servers do not accept the transmission of the e-mail.
- Account
  - Enter the mail account for logging into the mail server.
- Password
  - Enter the password for logging into the mail server.
- SMTP port number
  - Enter the port number of SMTP. Standard saver is 25.
- POP3 port number
  - Enter the port number of pop3. Standard saver is 110.

## 13.11 System settings

### 13.11.1 Clock settings

Set the date/clock of internal clock of this recorder.

- Proceed from the MENU settings.
- Move the focus to the setting item using direction key.
- By pressing the ENTER key on the item for setting, the screen moves to the input screen.

By selecting the system settings on the setting menu screen and then selecting the clock settings, the following screen is displayed.

|                       |          |            |
|-----------------------|----------|------------|
| Group1                |          | 2008/04/01 |
| Real trend            |          | 10:10:15   |
| Date                  | 08/04/01 | ▼          |
| Time                  | 10:10:13 | ▼          |
| Set                   |          |            |
| Time adjustment by DI | None     | ▼          |
| Display format        | YY/MM/DD | ▼          |
| Time zone             | +09:00   | ▼          |

#### ■ Date/Time

- Enter the date in the same way as the character entering
- The writing to the internal clock is executed at pressing the “Set” button. Press the “Set” button by the time signal, etc.

#### ■ Time adjustment by DI

- When specified digital input is turned ON, if ‘second’ of the time is less than 30, second is 0 and if ‘second’ is more than 30, ‘second’ is 0 and add 1 to ‘minute’.

#### ■ Display format

- Select the display format of the date.  
YY/MM/DD: Year/month/day  
MM/DD/YY: Month/day/year  
DD/MM/YY: Day/month/year

#### ■ Time zone

- Set the time difference from Greenwich mean time (GMT). This setting is reflected in sending time of e-mail header.

### 13.11.2 Key lock

- Proceed from the MENU settings.
- Move the focus to the setting item using direction key.
- By pressing the ENTER key on the item for setting, the screen moves to the input screen.

By selecting the system settings on the setting menu screen and then selecting the key lock, the following screen is displayed.

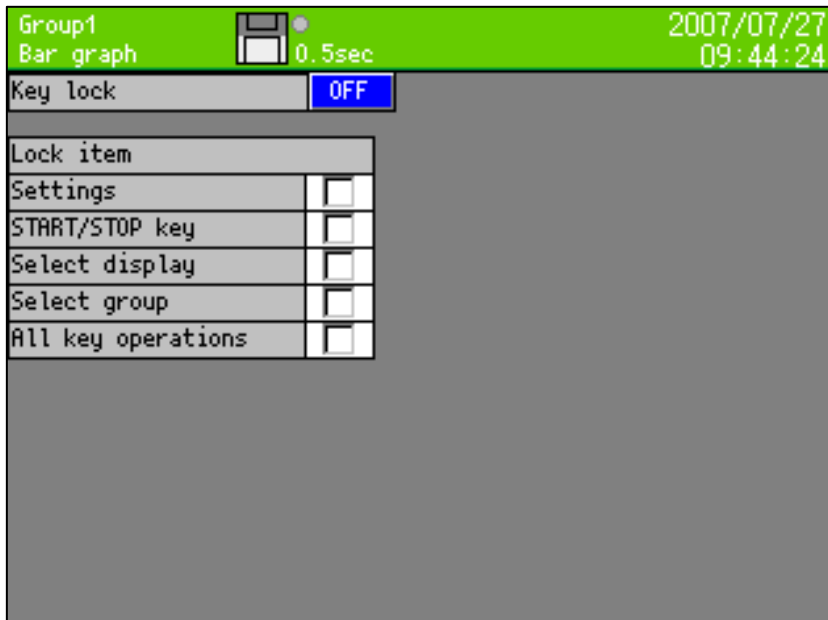

When the MENU settings is selected with the key lock ON, entering into the setting screen is disabled without a password. Set the password using “Password settings” on the next page.

(Message at the key lock ON)

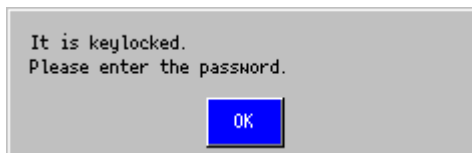

#### ■ Setting the key lock

- Set the key lock to ON or OFF.

#### ■ Setting the lock item

- Set the lock item by key lock.

| Item               | Content  |
|--------------------|--|
| Settings           | Lock for operation to enter the setting screen in the MENU/HOME settings.  |
| START/STOP key     | Lock for operation of START/STOP.  |
| Select display     | Lock for display selection of DISP menu.   |
| Select group       | Lock for group selection of DISP menu.   |
| All key operations | Lock all key operations. However, operation of entering MENU setting screen and operation of key on MENU setting screen can be operated. |

### 13.11.3 Password settings

- Proceed from the MENU settings.
- Move the focus to the setting item using direction key.
- By pressing the ENTER key on the item for setting, the screen moves to the input screen.

By selecting the system settings on the setting menu screen and then selecting the password setting, the following screen is displayed.

This password is used for the followings.

- For releasing the key lock
- Login password for displaying the web page

|              |  |            |      |            |          |
|--------------|--|------------|------|------------|----------|
| Group1       |  | Real trend | 1sec | 2006/06/09 | 11:28:56 |
| Old password |  |            |      |            |          |
| New password |  |            |      |            |          |

■ Setting the password (For entering password, refer to “7.3 Method of entering the characters”.)

- Set the password for the key lock.

■ For changing the password

- The password can be changed by entering the current password into the old password field and then by entering a new password into the new password field.

### 13.11.4 High order communications settings

- Proceed from the MENU settings.
- Move the focus to the setting item using direction key.
- By pressing the ENTER key on the item for setting, the screen moves to the input screen.

By selecting the system settings on the setting menu screen and then selecting the high order communications settings, the following screen is displayed.

| Group1                  |         | 2007/05/16            |  |
|-------------------------|---------|-----------------------|--|
| Real trend              |         | Rem. 28.2day 17:46:16 |  |
| TCP/IP                  |         |                       |  |
| Port number             | 11111   | ▼                     |  |
| Serial communication    |         |                       |  |
| Communication mode      | RTU     | ▼                     |  |
| Instrument address      | 01      | ▲▼                    |  |
| Bit Rate                | 9600bps | ▼                     |  |
| Communication character | 8N1     | ▼                     |  |

#### ■TCP/IP port number

- Set the port number for executing the high order communications by TCP/IP.
- When port number is set 502, it is possible to communicate by Modbus-TCP. When port number is set other than 502, this instrument communicates by own communication method.  
When use our company's PC software such as CISAS, TRWIN, KIDS, or PASS for high order application, set the number except 502. When use the PC software corresponding commercial Modbus-TCP, set 502.

#### ■Serial communications (Option)

\*When the instrument has not communication interface option, serial communication is not displayed.

Set the following items according to the settings of the high order application.

- Communication mode  
Select the communication mode from [RTU] or [ASCII].
- Instrument address  
Set a value from 1 to 31
- Bit rate  
Select the bit rate from [9600bps] or [19200bps].
- Communication character  
Select the combination of the data bit, parity, and stop bit.

### 13.11.5 Other settings

- Proceed from the MENU settings.
- Move the focus to the setting item using direction key.
- By pressing the ENTER key on the item for setting, the screen moves to the input screen.

By selecting the network settings on the setting menu screen and then selecting the other settings, the following screen is displayed.

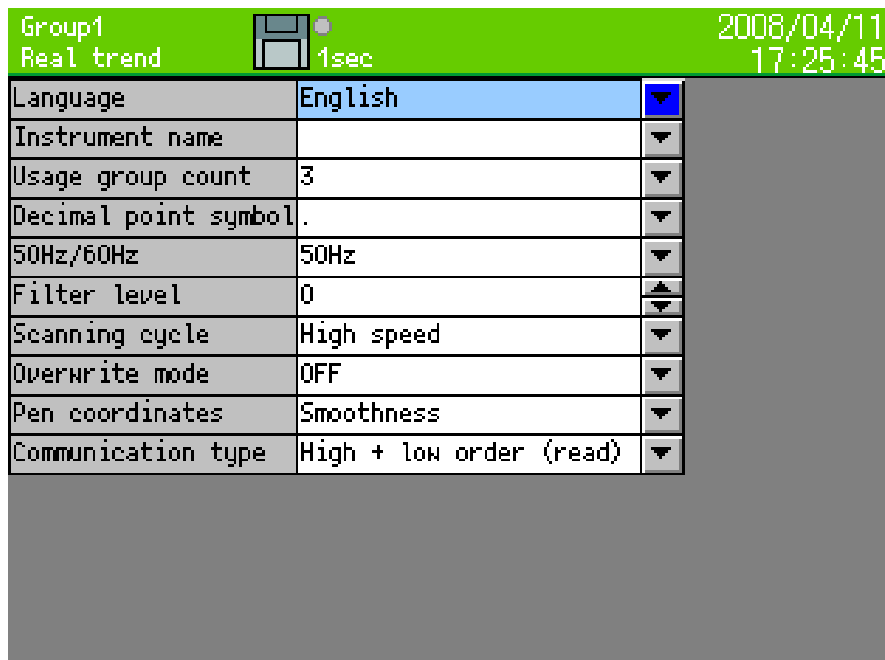

| Group1               |                         | 2008/04/11 |
|----------------------|-------------------------|------------|
| Real trend           |                         | 17:25:45   |
| Language             | English                 | ▼          |
| Instrument name      |                         | ▼          |
| Usage group count    | 3                       | ▼          |
| Decimal point symbol | .                       | ▼          |
| 50Hz/60Hz            | 50Hz                    | ▼          |
| Filter level         | 0                       | ▲▼         |
| Scanning cycle       | High speed              | ▼          |
| Overwrite mode       | OFF                     | ▼          |
| Pen coordinates      | Smoothness              | ▼          |
| Communication type   | High + low order (read) | ▼          |

- Language
  - Select the language from Japanese or English.
- Name of the instrument
  - It is used in the subject for forwarding the e-mail. "Message from (instrument name)" is used as the subject.
  - When it is in blank, the subject becomes "Message from Recorder".
- Setting the usage group count
  - The usage group count can be set from 1 to 5.
  - The smaller the usage group count the longer the period for recording it in internal memory (Refer to 9.9 Internal memory). When usage group count is 4 or more, recording within interval of less than 1 second is not possible.
- Setting the decimal point
  - Select ". (dot)", or ",", (comma)" for the decimal point.
  - When the decimal point is a comma and the file save format is the CSV, the file becomes the tab delimited text file. (Refer to 13.5 File settings.)
- Setting 50Hz/60Hz
  - Select the power frequency from 50Hz or 60 Hz.

■ Setting the filter level

- The input filter level can be set from 0 to 3.  
0 means no-filter, and 3 means the strongest filter.

■ Setting the overwrite mode

- With the overwrite mode is ON and the CF card remaining space decreases, the data is continuously written in the CF card by deleting the old file. When the overwrite mode is OFF and the CF card remaining space is insufficient, the data is not written in the CF card any more (The data recording is continued in the internal memory).

■ Setting the pen coordinate

- Select the coordinates calculation way of trend from smoothness/direct.
- In case of selecting the [Smoothness], even if the trend coordinate is changed by changed data, the trend coordinate is not changed from previous value until changing of the data exceed equivalent of 1 dot on the trend. When data is changed less than equivalent of 1 dot of trend coordinate, trend line does not swing.
- When select the [Direct], the trend coordinate from data is drawn directly.

(Example of drawing for [Direct] and [Smoothness])

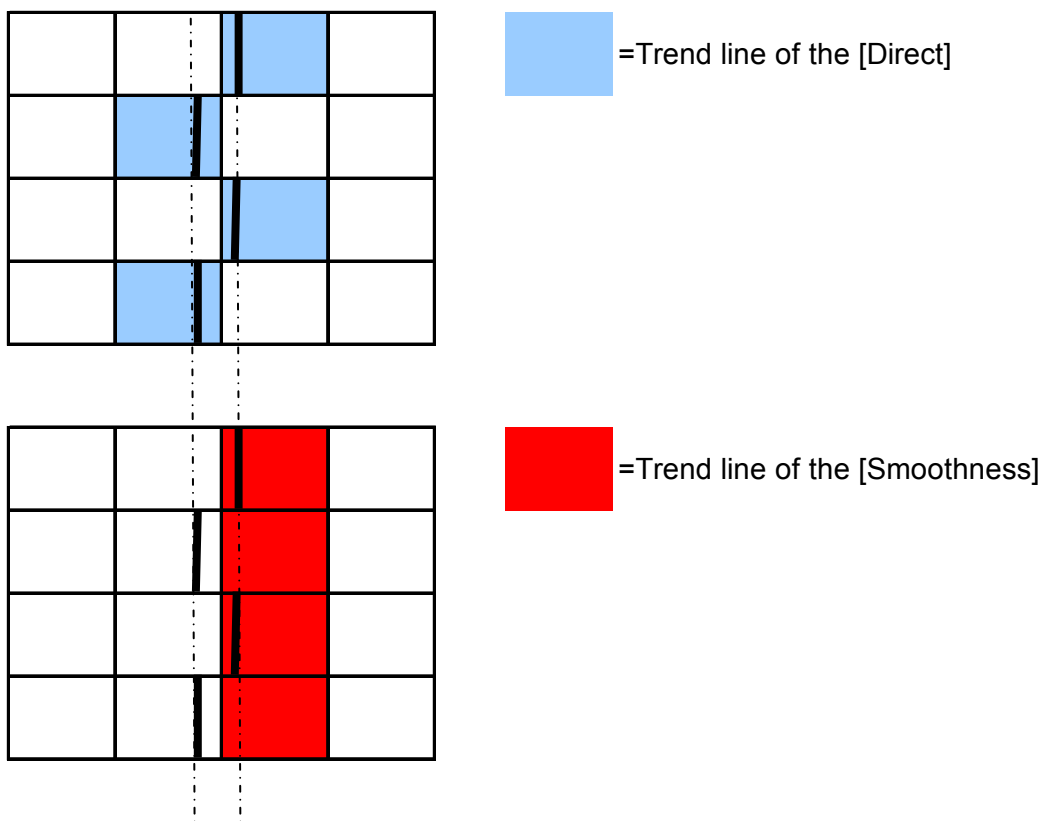

Range of the changing is less than range of 1 dot.

■ Select the communication type (option)

- Select the communication type from [High + low order (read)] or [High + low order (write)].  
Each communication types are following.

|                          |  |
|--------------------------|--|
| High + low order (read)  | Record the data in PLC and input data of the product of our company that is connected low order. |
| High + low order (write) | Transfer the input data of KR2000 to PLC.  |

# 14 Setting/Displaying on WEB screen

## 14.1 Display and settings of the Web screen

By using the web browser, the settings relating to inputs and records of this recorder can be configured and the data can be displayed.

### 14.1.1 Top page

By accessing to the IP address of this recorder via the web browser (The figure shows Internet Explorer.), the following screen is displayed after the password authentication.

The user name used for the password authentication is fixed as the “user” and cannot be changed.

However, the password can be changed to arbitrary characters at this recorder side. When the Link button is clicked, the screen moves to the “Recorder display” for displaying the same screen, on which the same operation can be executed, as this recorder on the browser, the “Data display” for displaying the data of each recording channel, the “Input settings” for setting input parameters of every channel, the “Alarm settings” for setting alarm parameters, the “Calculation settings” for setting formulas of every channel, the “Group settings” for setting record-related-items and the “Marker text setting” for setting marker texts.

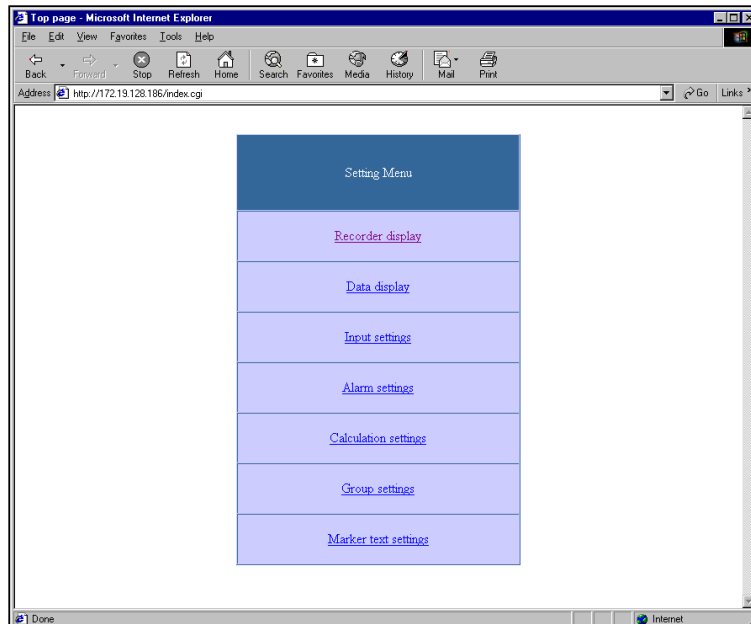



### 14.1.2 Recorder display

The same contents as this recorder are displayed. The keys arranged at the lower part of the screen can be operated like the keys of this recorder. Because of the image file used, it takes more time for loading than other screens. For preventing operational error, do not operate this recorder and this screen together at the same time.

Do not use the “Refresh”, “Back”, “Forward”, etc. on the browser and use the keys at the lower part screen.

When the ‘Refresh’ key at the lower right of the screen is clicked, the current display is reloaded. By clicking the “Auto refresh ON”, the screen is updated at about 1 minute interval. For stopping the auto refresh, click the “Auto refresh OFF”.

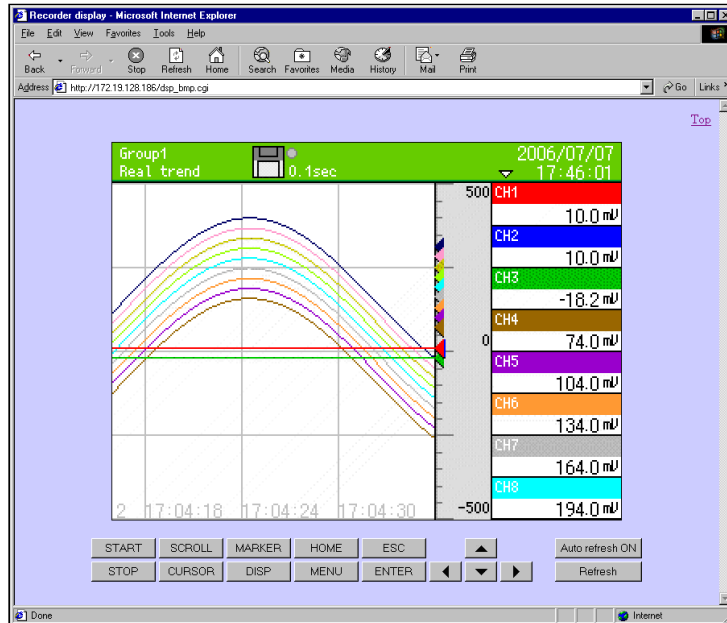

### 14.1.3 Data display

The data of 44 channels of this recorder are displayed with tag names and engineering units. Two kinds of screens are selectable, the screen fixedly displaying data obtained at the time of displaying it and the screen displaying data automatically updated every 10 seconds. When the link is clicked on the top page, the screen moves to the screen fixedly displaying data obtained at the time of displaying it. For moving to the automatic updating screen, click the “Start auto refresh” link at the lower part of the screen. Also, for moving to the fixed display during the automatic updating display, click the “Stop auto refresh” link at the lower part of the screen.

| Channel number | Tag  | Data   | Unit | Channel number | Tag  | Data   | Unit |
|----------------|------|--------|------|----------------|------|--------|------|
| 01             | CH01 | -403.3 | mV   | 23             | CH23 | 43.54  | V    |
| 02             | CH02 | -373.3 | mV   | 24             | CH24 | 46.54  | V    |
| 03             | CH03 | -343.3 | mV   | 25             | CH25 | 49.49  | V    |
| 04             | CH04 | -313.3 | mV   | 26             | CH26 | 52.49  | V    |
| 05             | CH05 | -283.3 | mV   | 27             | CH27 | 55.49  | V    |
| 06             | CH06 | -253.3 | mV   | 28             | CH28 | 58.49  | V    |
| 07             | CH07 | -223.3 | mV   | 29             | CH29 | 61.49  | V    |
| 08             | CH08 | -193.3 | mV   | 30             | CH30 | 64.49  | V    |
| 09             | CH09 | -163.3 | mV   | 31             | CH31 | 67.49  | V    |
| 10             | CH10 | -133.3 | mV   | 32             | CH32 | 70.49  | V    |
| 11             | CH11 | -103.3 | mV   | 33             | CH33 | 73.49  | V    |
| 12             | CH12 | -73.3  | mV   | 34             | CH34 | 76.49  | V    |
| 13             | CH13 | 13.54  | V    | 35             | CH35 | 79.49  | V    |
| 14             | CH14 | 16.54  | V    | 36             | CH36 | 82.49  | V    |
| 15             | CH15 | 19.54  | V    | 37             | CH37 | 85.49  | V    |
| 16             | CH16 | 22.54  | V    | 38             | CH38 | 88.49  | V    |
| 17             | CH17 | 25.54  | V    | 39             | CH39 | 91.49  | V    |
| 18             | CH18 | 28.54  | V    | 40             | CH40 | 94.49  | V    |
| 19             | CH19 | 31.54  | V    | 41             | CH41 | 97.49  | V    |
| 20             | CH20 | 34.54  | V    | 42             | CH42 | 100.49 | V    |
| 21             | CH21 | 37.54  | V    | 43             | CH43 | 103.49 | V    |
| 22             | CH22 | 40.54  | V    | 44             | CH44 | 106.49 | V    |

## 14.1.4 Input settings

This is for changing the settings of the input parameters of this recorder. By clicking the “Set” button after entering each item, the setting contents are written in this recorder. The settings of 6 channels are displayed on 1 screen and the displaying channel block can be switched by selecting the link from the “Channel number” table at the upper part of the screen. The settings cannot be changed during recording.

| Ch | Range type        | RJ       | Range   |         | Scale   |         | Burn out | Correction | Filter level   | Tag | Unit |
|----|-------------------|----------|---------|---------|---------|---------|----------|------------|----------------|-----|------|
|    |                   |          | Minimum | Maximum | Minimum | Maximum |          |            |                |     |      |
| 01 | -500.0 to 500.0mV | External | -500.0  | 500.0   | -500.0  | 500.0   | NONE     | 0.0        | System setting |     |      |
| 02 | -500.0 to 500.0mV | External | -500.0  | 500.0   | -500.0  | 500.0   | NONE     | 0.0        | System setting |     | mV   |
| 03 | -500.0 to 500.0mV | External | -500.0  | 500.0   | -500.0  | 500.0   | NONE     | 0.0        | System setting |     | mV   |
| 04 | -500.0 to 500.0mV | External | -500.0  | 500.0   | -500.0  | 500.0   | NONE     | 0.0        | System setting |     | mV   |
| 05 | -500.0 to 500.0mV | External | -500.0  | 500.0   | -500.0  | 500.0   | NONE     | 0.0        | System setting |     | mV   |
| 06 | -500.0 to 500.0mV | External | -500.0  | 500.0   | -500.0  | 500.0   | NONE     | 0.0        | System setting |     | mV   |

Contents of each setting

| Setting items | Contents   |
|---------------|--|
| Range type    | Select the input range.  |
| RJ            | Select the reference junction compensation from internal or external.  |
| Range Min     | Set the minimum value of the range.  |
| Range Max     | Set the maximum value of the range.  |
| Scale Min     | Set the minimum value of the scale.  |
| Scale Max     | Set the maximum value of the scale.  |
| Burnout       | Select the burn out from upscale, downscale or none.   |
| Correction    | Set the value (shift value) added to the input value.  |
| Filter level  | The input filter level can be set from 0 to 3. 0 means no-filter, and 3 means the strongest filter. When [system settings] is selected, settings are following [system settings] – [other settings]. |
| Tag           | Set the tag name for the data with maximum 15 characters.  |
| Unit          | Set the engineering unit for the data with maximum 7 characters.   |

### 14.1.5 Alarm setting

This is for changing the the settings of the alarm parameters of this recorder. By clicking the “Set” button after entering each item, the setting contents are written in this recorder. The settings of 6 channels are displayed on 1 screen and the displaying channel block can be switched by selecting the link from the "Channel number" table at the upper part of the screen.

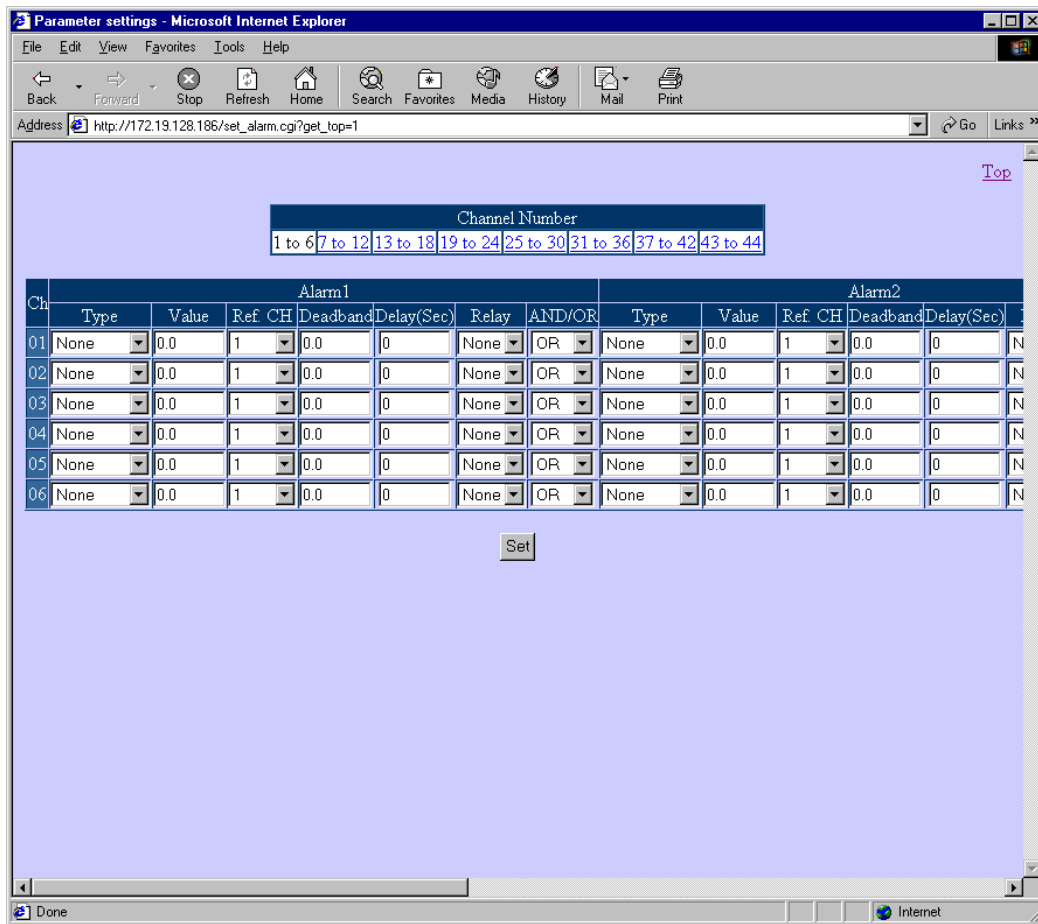

Contents of each setting

| Setting items           | Contents  |
|-------------------------|---|
| Alarm 1-4 Type          | Select the alarm type.  |
| Alarm 1-4 setting value | Set the alarm value of each alarm.  |
| Alarm 1-4 reference CH  | When the differential alarm is set in the alarm type of each alarm, select the reference channel. |
| Alarm 1-4 dead band     | Set the dead band of each alarm.  |
| Alarm 1-4 delay         | Set the delay of each alarm from 0 to 3600 seconds.   |
| Alarm 1-4 relay number  | Select the output destination relay number at the activation of each alarm.                       |
| Alarm 1-4 AND/OR        | Set the alarm output mode.  |

## 14.1.6 Calculation settings

The screenshot shows a web browser window titled "Calculate setting - Microsoft Internet Explorer". The address bar shows "http://172.19.128.196/set\_compute.cgi". The page content consists of two side-by-side tables. Each table has a header row with "Ch", "Calculate", and "Formula" columns. The first table contains rows numbered 01 to 22, and the second table contains rows numbered 23 to 44. Each row in both tables has a checkbox in the "Calculate" column and a text input field in the "Formula" column. A "Set" button is positioned below the second table. A "Top" link is visible in the top right corner of the page content area.

### Contents of each setting

| Setting items | Contents                                       |
|---------------|--|
| Calculate     | Select whether the calculation is used or not. |
| Formula       | Set the formula with maximum 48 characters.    |

### 14.1.7 Group settings

This is for changing the settings of the record-related-parameters of this recorder. When the “Set” button is clicked after entering each item, the setting contents are written in this recorder. The settings of one group are displayed on one screen. The group to be displayed can be switched by selecting from the "Group number" table on the upper part of the screen. The group that can be selected here is the groups from the Group 1 to the usage group count set in “System settings” → “Other settings” of this recorder. The settings of the group with the Record ON checked cannot be changed during recording.

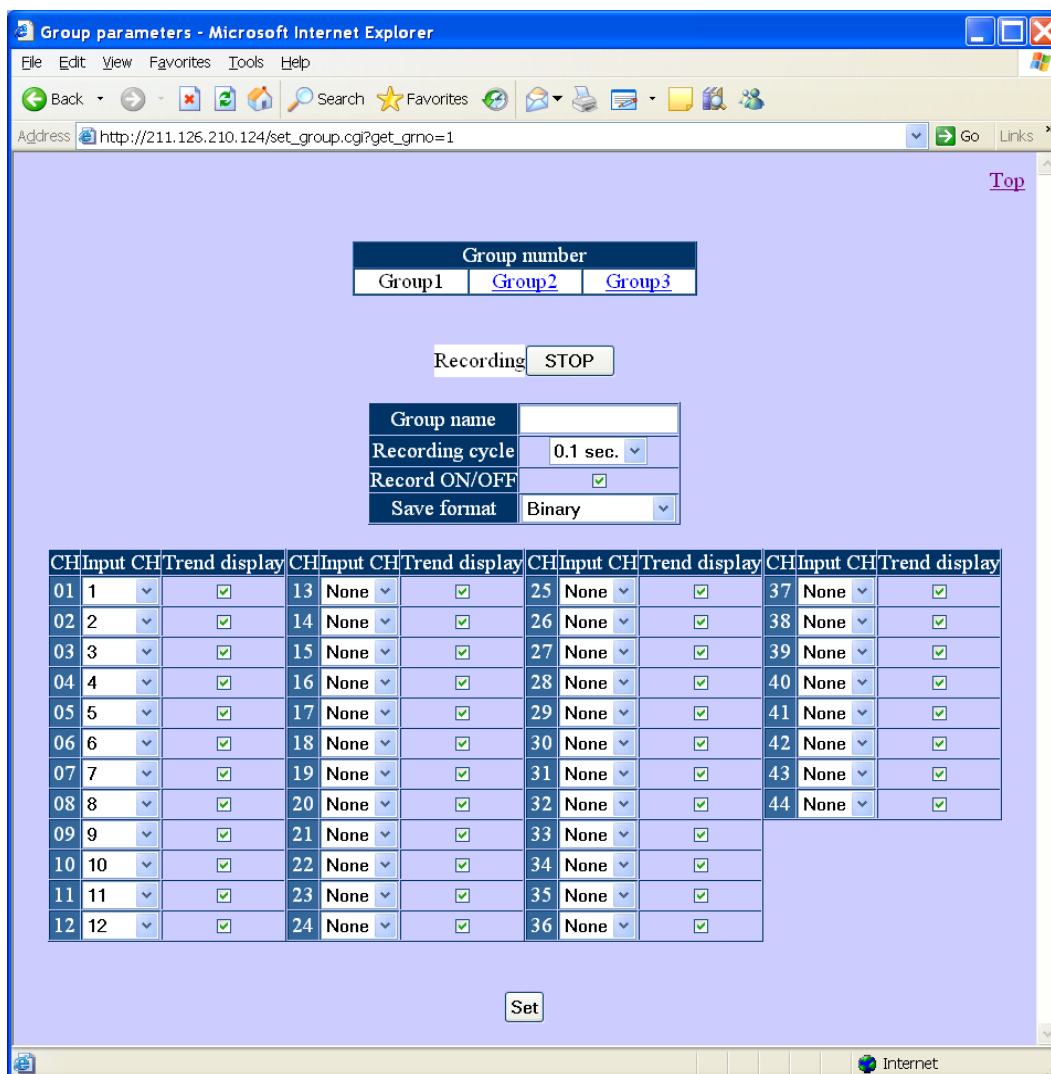

Contents of each setting

| Setting items    | Contents  |
|------------------|---|
| Group name       | Set the group name with maximum 16 characters.                                |
| Recording period | Select the time interval for displaying and recording the data.               |
| Recording ON/OFF | Select whether its group is recorded or not.                                  |
| Save format      | Select the file format for recording the data into CF card. (refer to 13.5)   |
| Input channel    | Select the input channel number to be recorded in each recording channel.     |
| Trend display    | Select whether the trends of each channel are displayed or not on the screen. |

### 14.1.8 Maker text setting

This is for changing the settings of the maker text parameters of this recorder. When the “Set” button is clicked after entering each item, the setting contents are written in this recorder. By setting the text at the last column (No. 10 in the figure), 10 more columns are displayed. Up to 50 texts can be registered. Refer to Para. 9.3 and 9.6 for writing the maker text on the trends.

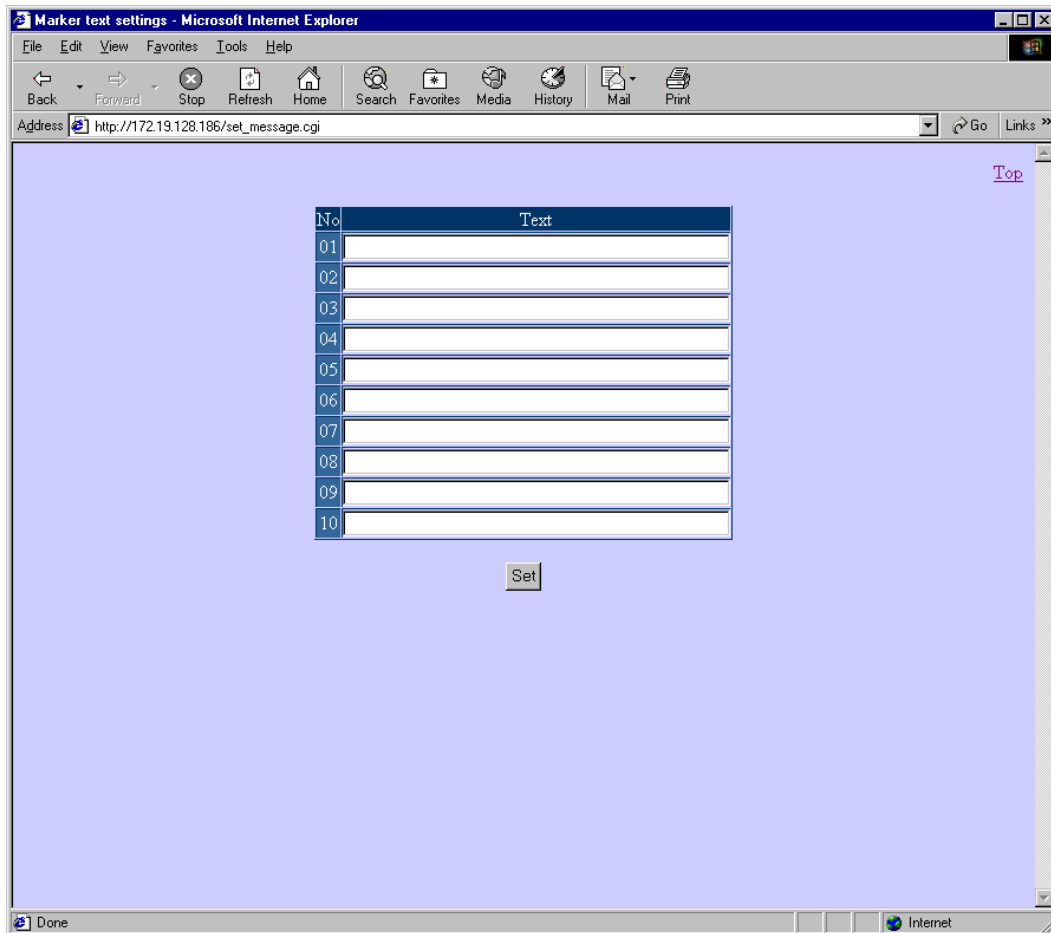

Contents of each setting

|                     |   |
|---------------------|---|
| Setting item        | Contents  |
| Text (No. 01 to 50) | Set the marker text with maximum 30 characters. |

# 15 Read the recorded data using USB

## 15.1 Outline

The recorded data stored in the CF card can be read through USB port installed in KR2000. Therefore, the required file can be copied to the PC without removing the CF card from the instrument.

## 15.2 Operation Environment

|                      |  |
|----------------------|--|
| Compatible PC        | Model loaded with USB1.1 or higher interface   |
| Compatible OS        | Windows2000 / XP   |
| Compatible USB cable | A type plug-B type plug  |
| Limitations          | <ul style="list-style-type: none"><li>▪ Operations by connecting via USB hub are not guaranteed.</li><li>▪ Write operations to file or folder (Including Move, name change) are not possible.</li><li>▪ CF card is not recognized depend on the USB port of your personal computer. Please acknowledge not supporting it in that case.</li></ul> |

## 15.3 Access to data file

Check that the CF card is inserted when KR2000 is in operating condition.

Open the front compartment and connect the USB port of the PC on which USB port of KR2000 and OS are being installed, with the compatible USB cable.

After connecting, CF card set in KR2000 is recognized as the removable disk on the OS. (Drive is automatically installed when connected with the PC initially. Restarting of OS is requested depending on the PC environment.)

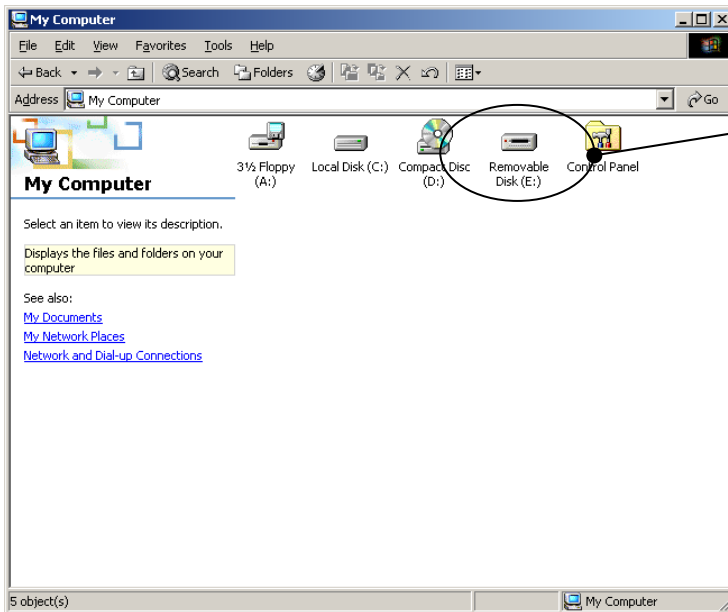

Removable disk added by USB connection. CF card in KR2000 can be assessed.

Contents of the CF card set in KR2000 can be read by accessing the recognized removable disk. Since it is a read-only file, copy the required file to the hard disk in the PC and then use it.

## Warning

- Do not disconnect the power supply when the data is being accessed.

Take care as the contents of the CF card may get destroyed and the data may get lost, when the power supply of KR2000 is disconnected, when the data file is being accessed.

- Do not remove the USB cable when the data is being accessed.

Operations of KR2000 system may get unstable on removing the USB cable, when the data file is being accessed. Moreover, in case to remove the cable, click on "Safe Removal of Hardware" icon displayed on the task tray on the PC screen and then execute the operations stipulated by OS.

- Do not insert and remove the USB cable from the instrument during recording.

Performance of the instrument will become unstable.

- Access to the data when it is being recorded

KR2000 system executes the access to the CF card when the storing operation is in progress. Although it can operate exclusively by the access from the PC, however, as the total performance decreases, access the data when the storing operation is being stopped,

- Update card information

After connecting the cable, the file on the updated CF card may not be displayed on the PC. When recording operation, write of setup file, snapshot is executed after connecting the cable, file information is updated by inserting and removing the CF card.



# 16 Low order communications (read) (option)

## 16.1 Outline

**\*When use low order communications, set communication type to [High + low order (read)] (Refer to 13.11.5).**

Low order communications are functions that this recorder works as a master unit (high order instrument) communications and reading data of the other instruments which are connected as slave units (low order instruments) assigned for input channel of this recorder and then displaying and recording the data. This recorder and low order instruments communicate by serial communication of RS-485 communication standard compliance.

The “range”, “scale”, “RJ”, and “burn out” settings can be set for lower order instrument.\*1

Data requirement for each instrument is approximately 1 second (all points per 1 instrument). When connect 5 instruments to low order side, data renewal period is approximately 5 seconds.\*3

\*1 LT230, LT350/370, LT830, JU, JW has only data collective function, not setting.

\*2 Data renewal time is different depending on regulated points only JW.

Less than 10 points: number of connection lower-order communication instrument x 1 (second)

10-13 points: number of connection lower-order communication instrument x 2 (seconds)

More than 13 points: number of connection lower-order communication instrument x 3 (seconds)

\*3 Except JW

\*4 Data of following PLC made of Mitsubishi Electric can be read.

- MELSEC AnACPU series
- MELSEC QnACPU series
- MELSEC QnASCPU series
- MELSEC QCPU series
- MELSEC FX series

Need the communication unit etc. that is corresponded communication control procedure model 4.

Following devices can be inputted.

- D0000 to D1023
- M0000 to M2047

\*5 Data of following PLC made of Omron can be read.

- The instrument which is corresponded SYSMAC C mode command communication.

Following channels can be inputted.

- Data memory (DM) area: D0000 to D9999
- CIO (input and output relay etc.) area: 0 to 6143

When communicate with PLC of Omron, need line convertors (SC8-10) same as the number of PLC (refer to 5-7(5)).

—Instrument can be connected low order side—

1. BR
2. AL3000
3. AH3000
4. SE3000
5. KE3000
6. LE5000
7. KR2000/3000
8. LT230
9. LT350/370
10. LT450/470
11. LT830
12. JU
13. JW
14. MELSEC series
15. SYSMAC series

### ■ Lower-order communication (read) outline

- Model: KR21□□—Q□□
- Connection quantity: Maximum 5
- Maximum input points\*: 30 points (KR216□)/24 points (KR212□)  
\*Possible to register on CH7 (KR216□) or from CH13 to CH36 (KR212□) of the recorder.
- Data renewal period: approximately 1 second per 1 instrument.\*  
\* Display of renewal may delay in this instrument depending on the condition of data renewal or communication response delay of low order side instrument.
- Communication time out: approximately 1 second for each instrument (no retry). Retain the data of last value.\*

\*When communication time out is occur for the 60th times in a row, display and record “UNDER”.

## 16.2 Procedure of connection setting to low order instrument

After connecting between low order communication terminal of this recorder and low order instruments, set this recorder (high order instrument) and low order instruments following the procedure. See “5.7 Connection of communication I/F terminal”, instruction manual of communication interface of each instrument, and connection instruction manual for detail of connection. (Terminal resistance is installed to the instrument which is set one end or both ends of standard communication line, however terminal resistance is not installed depend on the environment.)

<<Example>>

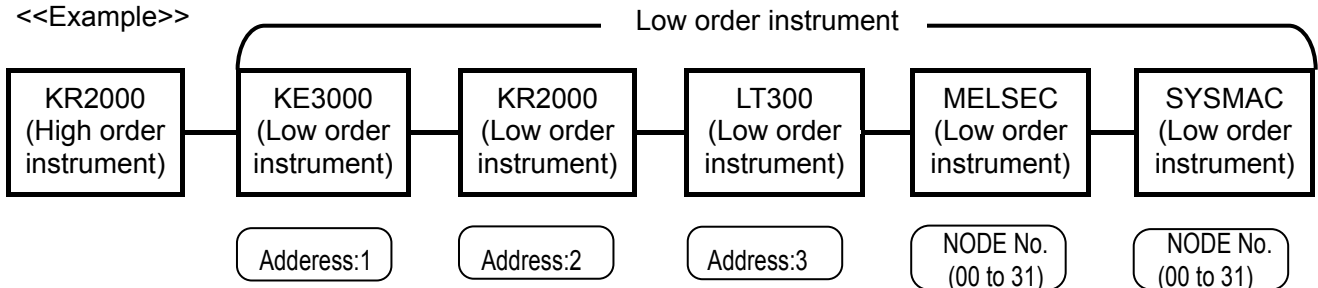

### 16.2.1 Setting of low order instrument

- (1) Set communication address (instrument number) of low order instrument from 1 to 5 without overlap (Node number of PLC is optional number which is not overlapping).
- (2) Set communication of each low order instrument by specification of below. See instruction manual of each instrument for setting method.

Baud rate :9600 bps  
 Length of data :8 bit  
 Stop bit :1 bit  
 Parity :None

### 16.2.2 Register to the instrument (product of our company)

- (1) Press the Menu key in operation screen of the instrument, and select “system setting” → “low order communication (read)” in the list, then press the ENTER key. (Display “lower communication (read)” only in lower communication (read) option product)
- (2) Select appropriate name of the model from a list of “model”. Register low order instrument corresponding each communication address (instrument number) 1 - 5 to COM1-COM5.
- (3) Register points to “input points”

| COM  | Model   | Input points | PLC node | Top address | Read count |
|------|---------|--------------|----------|-------------|------------|
| COM1 | KE      | 12           | ---      | ---         | ---        |
| COM2 | KR2/3   | 6            | ---      | ---         | ---        |
| COM3 | LT2/3/8 | 1            | ---      | ---         | ---        |
| COM4 | AL/AH   | 6            | ---      | ---         | ---        |
| COM5 | BR      | 4            | ---      | ---         | ---        |

- ◆ Example of setting  
 COM1:KE/12points  
 COM2:KR2/6points  
 COM3:LT3/1point  
 COM4: AL/6points  
 COM5: BR/4points

Name of instrument which is displayed on the list is displayed convenient. \*1

| On the list | Model of our company  |
|-------------|-----------------------|
| SE3         | SE3000                |
| AL/AH       | AL3000/AH3000         |
| KR2         | KR2000                |
| LE5         | LE5000                |
| LT2/3/8     | LT230/LT350/370/LT830 |
| LT4         | LT450/470             |

Data of LT (each series), JU, and JW is assigned like below for CH data.

| L T  |   |
|------|---|
| CH01 | Measured value (PV)                       |
| CH02 | Measured value (SV)                       |
| CH03 | Control output value (MV: Heating output) |
| CH04 | Control output value (MV: cooling output) |
| CH05 | Execution SV                              |
| CH06 | Execution EV1                             |
| CH07 | Execution EV2                             |
| CH08 | Execution EV3                             |
| CH09 | Execution EV4                             |
| CH10 | Execution P                               |
| CH11 | Execution I                               |
| CH12 | Execution D                               |
| CH13 | Execution No.                             |

| JW   |   |
|------|---|
| CH01 | Voltage level (average)                     |
| CH02 | Current value (average)                     |
| CH03 | Electric value                              |
| CH04 | None assigned                               |
| CH05 | Voltage level (between U phase and V phase) |
| CH06 | Current value (U phase)                     |
| CH07 | Load resistance value (U phase)             |
| CH08 | Voltage level (between V phase and W phase) |
| CH09 | Current value (V phase)                     |
| CH10 | Load resistance value (V phase)             |
| CH11 | Voltage level (between W phase and U phase) |
| CH12 | Current value (W phase)                     |
| CH13 | Load resistance value (W phase)             |
| CH14 | Initial resistance value (U phase)          |
| CH15 | Initial resistance value (V phase)          |
| CH16 | Initial resistance value (W phase)          |

| J U  |                       |
|------|-----------------------|
| CH01 | Voltage level         |
| CH02 | Current value         |
| CH03 | Electric value        |
| CH04 | Load resistance value |

### 16.2.3 Register to the instrument (PLC)

- (1) Select “system setting” → “low order communications (read)” on the menu screen of the recorder.  
 \* “low order communication (read)” is displayed when the recorder has low order communication (read) option.
- (2) Select the name of the model from the list of “model”. Then register PLC on each COM1 to COM5.
- (3) Register administrate address of the recorder on “top address” and “read address”.

|      | Model  | Input points | PLC node | Top address | Read count |
|------|--------|--------------|----------|-------------|------------|
| COM1 | MELSEC | ----         | 0        | D0000       | 5          |
| COM2 | MELSEC | ----         | 1        | D0000       | 5          |
| COM3 | MELSEC | ----         | 2        | D0000       | 5          |
| COM4 | MELSEC | ----         | 3        | D0000       | 5          |
| COM5 | MELSEC | ----         | 4        | D0000       | 5          |

### 16.2.4 Register CH number of low order instrument

- (1) Press the MENU key at the operation screen of the recorder, and select “input computation programming” on the list.
- (2) Move the focus to “input type” of CH which is registered low order instrument, and press the ENTER key.  
 Select model which is registered “16.2.2 Setting of low order instrument” from the displayed list, and press the ENTER key.
- (3) Set CH number of low order instrument which is resisted “CH” column of third row.

| CH. | Input type   | CH. | Tag | Unit |
|-----|--------------|-----|-----|------|
| 01  | AI           | 1   |     | U    |
| 02  | AI           | 2   |     | U    |
| 03  | AI           | 3   |     | U    |
| 04  | AI           | 4   |     | U    |
| 05  | AI           | 5   |     | U    |
| 06  | AI           | 6   |     | U    |
| 07  | COM1 (KR2)   | 1   |     | U    |
| 08  | ----         | 1   |     | U    |
| 09  | COM1 (KR2)   | 1   |     | U    |
| 10  | COM2 (AL/AH) | 1   |     | U    |
| 11  | COM3 (KE)    | 1   |     | U    |
| 12  | COM4 (LE5)   | 1   |     | U    |
| 13  | ----         | 1   |     | U    |
| 14  | ----         | 1   |     | U    |

## 16.2.5 Input setting of low order instrument

- (1) Move the focus to “input computation programming” of “CH” of the left side, press the ENTER key. Display detail setting screen like below.

|                             |               |              |       |    |
|-----------------------------|---------------|--------------|-------|----|
| Group1                      | 2007/05/18    |              |       |    |
| Real trend                  | 11:15:24      |              |       |    |
| 1sec                        |               |              |       |    |
| CH. 07                      | COH1(KR2)-CH1 | Copy from 07 | to 07 | Go |
| Range type                  | 10U           |              |       |    |
| Range                       | -10.00        | to           | 10.00 |    |
| Scale                       | -10.00        | to           | 10.00 |    |
| Correction                  | 0.00          |              |       |    |
| RJ                          | ----          |              |       |    |
| Burn out                    | ----          |              |       |    |
| Tag                         |               |              |       |    |
| Unit                        | U             |              |       |    |
| Calculate                   | OFF           |              |       |    |
| Formula                     |               |              |       |    |
| Load Send Load all Send all |               |              |       |    |

- (2) Move the focus to INPUT button for getting setting contents of relevant CH of low order instrument, and press the ENTER key. Move the focus to All points input button for getting setting contents of all registered points, and ENTER key.

Following message is shown when input of setting contents is done normally.

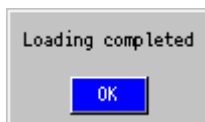

Press the ENTER key for returning.

If the input is incorrect, the following message is displayed.

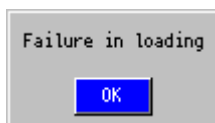

Press the ENTER key for returning, and move the focus to INPUT button, then press the ENTER key again. When message of “INPUT Complete” is not shown, communication is not normal. Check the setting and connection of this instrument and low order instruments again.

(3) When changing the setting from this recorder for appropriate CH of low order instrument, perform following procedure. (The instrument which is not change the setting is not displayed [transfer] [all] [points transfer] button.)

When change the setting only displayed CH, move the focus to [transmitting], and press the [ENTER] key. In case of changing and setting of all needed CH, move the focus to [all points] after finishing the change of all setting, then press the [ENTER] key. Following message is shown when input of setting contents is done normally. After sending contents of setting is complete, the following message is displayed.

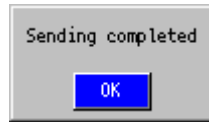

Press the ENTER key for returning.

If the input is incorrect, the following message is displayed.

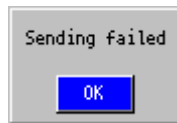

Press the ENTER key for returning, and move the focus to INPUT button, then press the ENTER key again. When message of "INPUT Complete" is not shown, communication is not normal. Check the setting and connection of this instrument and low order instruments again.

(4) After finish the setting of CH press the [ESC] key and save the setting.

(5) After setting of the above procedure, start data acquisition. When register the CH which is allotted to low order instrument at [display setting] – [group parameter], data of low order instrument can be displayed and recorded (refer to 13.3.2).

# 17 Low order communications (write) (option)

## 17.1 Outline

**\*When use low order communications, set communication type to [High + low order (write)]. (Refer to 13.11.5)**

Low order communications (write) has the function that communicate for high order instrument and write measurement and calculation data of this recorder to connected low order instrument. This recorder and low order instruments communicate by serial communication of RS-422A or RS-485 communication standard compliance.

—Instrument can be connected low order side—

1. MELSEC series<sup>\*1</sup>
2. SYSMAC series<sup>\*2</sup>

\*1 Data of following PLC made of Mitsubishi Electric can be read.

- MELSEC AnACPU series
- MELSEC QnACPU series
- MELSEC QnASCPU series
- MELSEC QCPU series
- MELSEC FX series

Need the communication unit etc. that is corresponded communication control procedure model

4.

Following devices can be inputted.

- D0000 to D1023
- M0000 to M2047

\*2 Data of following PLC made of Omron can be read.

- The instrument which is corresponded SYSMAC C mode command communication.

Following channels can be inputted.

- Data memory (DM) area: D0000 to D9999
- CIO (input and output relay etc.) area: 0 to 6143

When communicate with PLC of Omron, need line convertors (SC8-10) same as the number of PLC (refer to 5-7(5)).

### ■ Low order communications (write) specification outline

- Model: KR21□□-Q□□

- Connection quantity: Maximum 5

- Maximum writing points\*: 44

\*Possible to write all channels data of this instrument.

- Data renewal period: Approximately 1 second per 1 instrument\*

\*Display of renewal may delay in this instrument depending on condition of data renewal or communication response delay of low order side instrument.

- Communication time out: Approximately 1 second for each instrument \*(no retry).

\*When the instrument include communication time out and has communication error for 60th times,, display error message.

## 17.2 Register to the instrument

- (1) Select “system setting” → “low order communications (read)” on the menu screen of the recorder  
 \*“low order communication (write)” is displayed when the recorder has low order communication (write) option.
- (2) Select the name of the model from the list of “model”. Then register PLC on each COM1 to COM5.
- (3) Register address which is written from this recorder on “top address” and “write count”.
- (4) Register top channel of source of write on “top CH”.

| Group1     |        | 2008/01/09 |             |             |        |
|------------|--------|------------|-------------|-------------|--------|
| Real trend |        | 16:41:44   |             |             |        |
|            | Model  | PLC node   | Top address | Write count | Top CH |
| COM1       | MELSEC | 0          | D0000       | 10          | 1      |
| COM2       | SYSMAC | 0          | D0000       | 5           | 11     |
| COM3       | ----   | 0          |             | 0           | 0      |
| COM4       | ----   | 0          |             | 0           | 0      |
| COM5       | ----   | 0          |             | 0           | 0      |

On the setting of the above,

COM1: Write the data of CH1 to 10 of KR to “D0000 to D0009” of MELSAC of PLC node “0”.

COM2: Write the data of CH11 to 15 of KR to “D0000 to D0004” of SYSMAC of PLC node “0”.



# 18 Scale calibration

## 18.1 Scale calibration

To maintain the measuring accuracy, it is recommended to calibrate this instrument every year.

| Calibration Name     | Description   |
|----------------------|---|
| Zero-span adjustment | <p>Execute the adjustment by inputting the zero and span of each measurement range.</p> <p>* This recorder process inputs with one AD converter per four channels. Therefore, execute the adjustment by inputting the zero and span of each range 2 times for 6 points specification and 3 times for 12 points specification.</p> |

※ The sensor correction (shift of value) for each channel can also be performed. (Refer to 13.2 Input operation settings)

## 18.2 Calibration Environment

| Items               | Reference conditions |
|---------------------|----------------------|
| Ambient temperature | 23°C±2°C             |
| Ambient humidity    | 50%±10%              |
| Power voltage       | 100V AC±1%           |
| Power frequency     | 50Hz or 60Hz±0.5%    |

## 18.3 Preparation

### 18.3.1 Preparation of tools

| Tools                          | Input types |              |            | Remarks                                 |
|--------------------------------|-------------|--------------|------------|---|
|                                | DC voltage  | Thermocouple | Resistance |   |
| DC voltage current generator   | ○           |              |            | Accuracy: Better than ±0.05%            |
| Reference junction compensator |             | ○            |            | 0°C±0.2°C                               |
| Thermocouple for test          |             | ○            |            | Same type of thermocouple as input type |
| Standard variable resistor     |             |              | ○          | Accuracy: Better than ±0.05%            |
| 3-core copper wire             |             |              | ○          | Same resistance value per core          |

### 18.3.2 Before calibration

- (1) Attach the terminal board cover and turn power on.
- (2) Take the warm-up time for more than 30 minutes until this recorder is stabilize. (The ideal warm-up period is more than 1 hour.)

#### Remarks

Adjustment

The check and adjustment of measured values need careful cautions for the adjustment work besides tools such as standard tools and reference conditions. When the check and adjustment of measured values are required, contact your local CHINO's sales agent.

## 18.4 Connection

Connections depend upon the input types. Connect tools such as standard tools to the measuring input terminals to be adjusted.

### Caution

■ Turn off the power source before connections

Turn off the power source before connections for preventing electric shock.

(1) In case of DC voltage input

CH2, CH5, CH11 are the channels for adjustment in case of KR21\*0.

For the adjustment, connect to the CH2, CH5, CH11 all together as shown in the right figure.

CH2 is the channel for adjustment in case of KR21\*1.

●KR21\*0

CH1-CH4 are adjusted by adjustment of CH2.

CH5-CH8 are adjusted by adjustment of CH5.

CH9-CH12 are adjusted by adjustment of CH11.

■ Use only CH2, CH5 for 6 channels specification

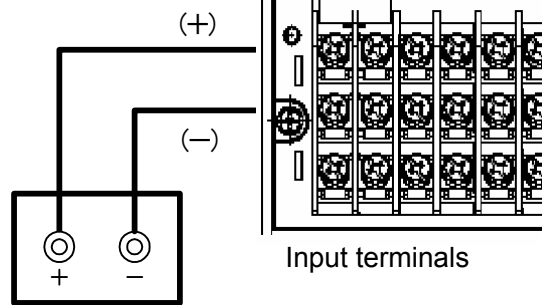

DC standard voltage generator

●KR21\*1

CH1-CH12 (if there is 6 channel specification, channels are CH1-CH6) are adjusted by adjustment of CH2.

(2) In case of the resistance thermometer input

CH2, CH5, CH11 are the channels for adjustment in case of KR21\*0.

For the adjustment, connect to the CH2,

CH5, CH11 independently as shown in the right figure.

CH2 is the channel for adjustment in case of KR21\*1.

●KR21\*0

CH1-CH4 are adjusted by adjustment of CH2

CH5-CH8 are adjusted by adjustment of CH5

CH9-CH12 are adjusted by adjustment of CH11

■ Use only CH2, CH5 for 6 channels specification

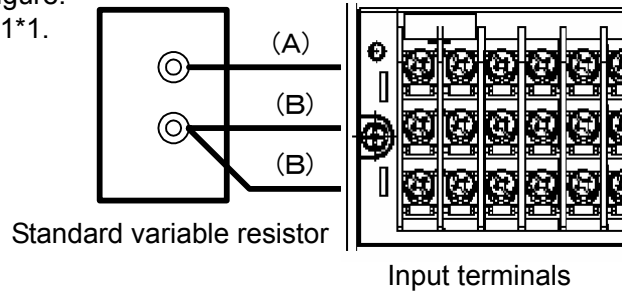

Standard variable resistor

Input terminals

●KR21\*1

CH1-CH12 (if there is 6 channel specification, channels are CH1-CH6) are adjusted by adjustment of CH2.

(3) In case of the thermocouple input (KR21\*0 and KR21\*1 are same connection)  
 CH1, CH6, CH12 are the channels for adjustment.  
 For the adjustment of thermocouples, connect to the CH1, CH6, CH12 independently as shown in the right figure.

- CH1, CH6, CH12 are used for adjusting 3 elements for measuring the terminal temperature.
- Use only CH1, CH6 for 6 channels specification

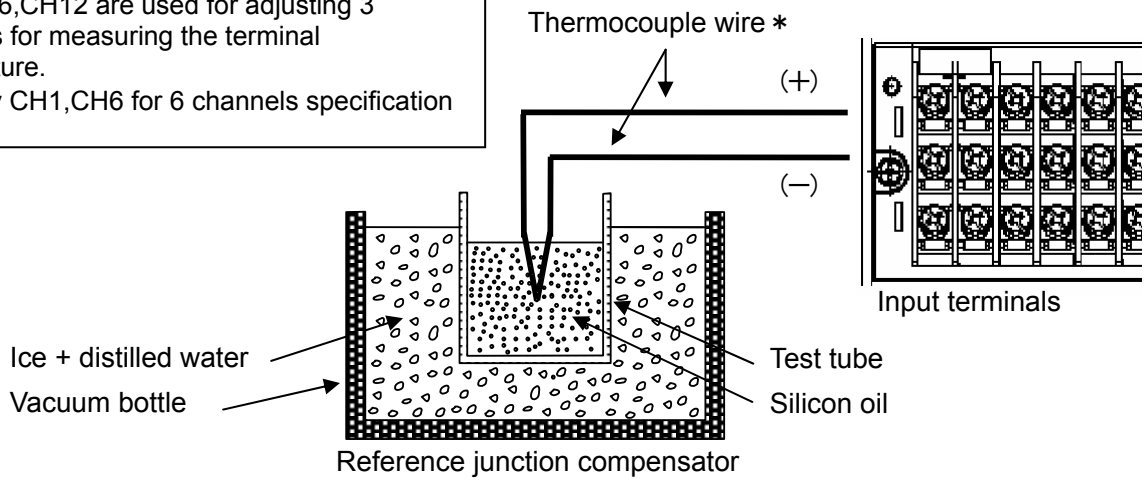

The electromotive force of the thermocouple input becomes small by the electromotive force equivalent to the temperature at terminals. The instrument itself compensates for its value. This is called the reference junction compensation. The input for the adjustment is entered with the power of a reference unit (0°C at reference). Accordingly, the reference junction compensator is used for reducing the reference junction compensated value.

# 18.5 Zero and span adjustment

## 18.5.1 Calibration screen

- Execute the range adjustment by inputting the zero and span values of the input range to each input channel for adjustment.
- Move the focus to adjusting range by direction key.
- Press the ENTER key at the range to be adjusted to move to the adjustment mode.

By pressing the MENU key on the operation screen and then pressing HOME key more than 5 seconds, the following calibration screen is displayed. The data displayed show the AD account values after adjustment.

| Group1     |    |     | 2006/06/09 |      |      |      |      |      |
|------------|----|-----|------------|------|------|------|------|------|
| Real trend |    |     | 11:41:09   |      |      |      |      |      |
| Range      |    |     | Zero       |      |      | Span |      |      |
| 6.9mV      | Go | CLR | 0000       | 0000 | 0000 | 0000 | 0000 | 0000 |
| 13.8mV     | Go | CLR | 0000       | 0000 | 0000 | 0000 | 0000 | 0000 |
| 27.6mV     | Go | CLR | 0000       | 0000 | 0000 | 0000 | 0000 | 0000 |
| 55.2mV     | Go | CLR | 0000       | 0000 | 0000 | 0000 | 0000 | 0000 |
| 69mV       | Go | CLR | 0000       | 0000 | 0000 | 0000 | 0000 | 0000 |
| 200mV      | Go | CLR | 0000       | 0000 | 0000 | 0000 | 0000 | 0000 |
| 500mV      | Go | CLR | 0000       | 0000 | 0000 | 0000 | 0000 | 0000 |
| 2V         | Go | CLR | 0000       | 0000 | 0000 | 0000 | 0000 | 0000 |
| 5V         | Go | CLR | 0000       | 0000 | 0000 | 0000 | 0000 | 0000 |
| 10V        | Go | CLR | 0000       | 0000 | 0000 | 0000 | 0000 | 0000 |
| 20V        | Go | CLR | 0000       | 0000 | 0000 | 0000 | 0000 | 0000 |
| 50V        | Go | CLR | 0000       | 0000 | 0000 | 0000 | 0000 | 0000 |
| Pt150      | Go | CLR | 0000       | 0000 | 0000 | 0000 | 0000 | 0000 |
| Pt300      | Go | CLR | 0000       | 0000 | 0000 | 0000 | 0000 | 0000 |

## 18.5.2 Adjustment of the DC voltage input range

Connect as shown in “16.4 Connection (1) In case of the DC voltage input”.

In case of the KR21\*0, connect to the CH2, CH5, CH11 all together, and execute the adjustment by inputting the voltage for the adjustment range.

In case of the KR21\*1, connect to the CH2, and execute the adjustment by inputting the voltage for the adjustment range.

- (1) Select “Go” at the range to be adjusted and press the ENTER key.

■ Adjustment screen of KR21\*0

| Group1     |    |     | 2007/05/16   |      |     |       |       |       |
|------------|----|-----|--------------|------|-----|-------|-------|-------|
| Real trend |    |     | Rem. 7. 3day |      |     |       |       |       |
| Range      |    |     | Zero         |      |     | Span  |       |       |
| 6.9mV      | Go | CLR | -48          | -118 | 13  | 23571 | 23561 | 23674 |
| 13.8mV     | Go | CLR | -26          | -67  | 10  | 27058 | 27087 | 27143 |
| 27.6mV     | Go | CLR | -12          | -32  | 6   | 26511 | 26554 | 26572 |
| 55.2mV     | Go | CLR | -3           | -13  | 5   | 22731 | 22779 | 22775 |
| 69mV       | Go | CLR | -2           | -12  | 5   | 25633 | 25689 | 25679 |
| 200mV      | Go | CLR | 1            | -3   | 4   | 25655 | 25722 | 25714 |
| 500mV      | Go | CLR | 2            | 0    | 5   | 26720 | 26771 | 26768 |
| 2V         | Go | CLR | 3            | 1    | 5   | 26200 | 26218 | 26226 |
| 5V         | Go | CLR | -5           | -15  | 7   | 26080 | 26133 | 26120 |
| 10V        | Go | CLR | 1            | -3   | 5   | 16690 | 16727 | 16720 |
| 20V        | Go | CLR | 2            | -2   | 5   | 25395 | 25455 | 25437 |
| 50V        | Go | CLR | 3            | 0    | 5   | 26451 | 26492 | 26478 |
| Pt150      | Go | CLR | -52          | -100 | -76 | 23459 | 23515 | 23533 |
| Pt300      | Go | CLR | -17          | -39  | -27 | 18783 | 18860 | 18873 |

■ Adjustment screen of KR21\*1

| Group1     |    |     | 2007/05/16   |  |  |      |  |  |
|------------|----|-----|--------------|--|--|------|--|--|
| Real trend |    |     | Rem. 7. 2day |  |  |      |  |  |
| Range      |    |     | Zero         |  |  | Span |  |  |
| 6.9mV      | Go | CLR |              |  |  |      |  |  |
| 13.8mV     | Go | CLR |              |  |  |      |  |  |
| 27.6mV     | Go | CLR |              |  |  |      |  |  |
| 55.2mV     | Go | CLR |              |  |  |      |  |  |
| 69mV       | Go | CLR |              |  |  |      |  |  |
| 200mV      | Go | CLR |              |  |  |      |  |  |
| 500mV      | Go | CLR |              |  |  |      |  |  |
| 2V         | Go | CLR |              |  |  |      |  |  |
| 5V         | Go | CLR |              |  |  |      |  |  |
| 10V        | Go | CLR |              |  |  |      |  |  |
| 20V        | Go | CLR |              |  |  |      |  |  |
| 50V        | Go | CLR |              |  |  |      |  |  |
| Pt150      | Go | CLR |              |  |  |      |  |  |
| Pt300      | Go | CLR |              |  |  |      |  |  |

- (2) Since the window indicating the voltage value for inputting is displayed, input its value to this recorder.

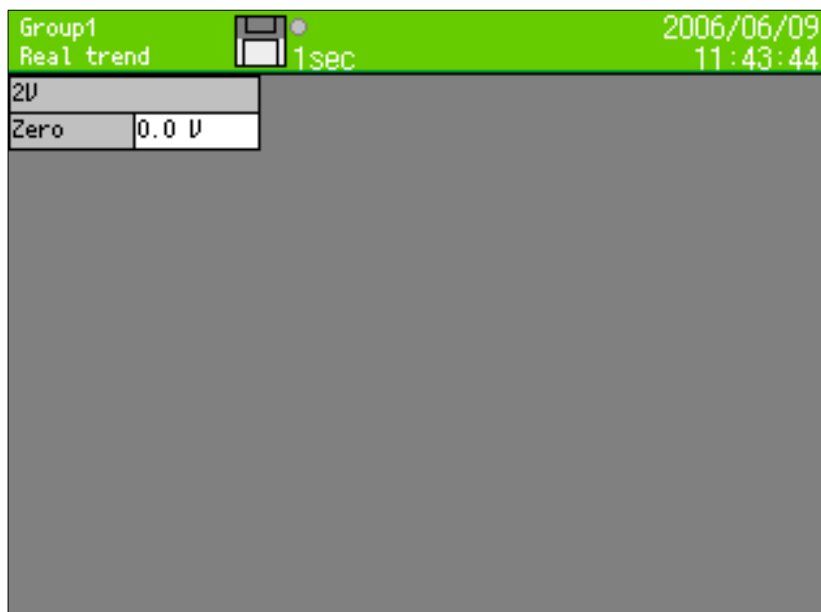

- (3) Adjust the zero point.

(Example) For the adjustment of the  $\pm 2V$  range

- Input the voltage of 0V with the DC standard voltage generator.

- (4) After inputting the zero point for about 5 seconds, press the ENTER key.

- (5) Adjust the span point.

(Example) For the adjustment of the  $\pm 2V$  range

- Input the voltage of +2V with the DC standard voltage generator.

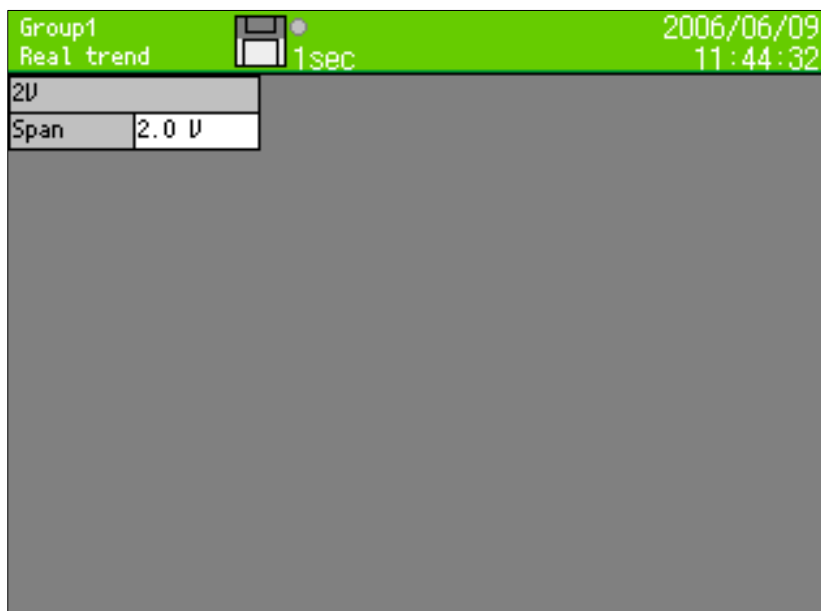

- (6) After inputting the span point for about 5 seconds, press the ENTER key.

- (7) After the adjustment of the span point, the screen is returned to the calibration screen for all ranges.

- (8) Repeat from (1) to (6) for the adjustment of other ranges.

### 18.5.3 Adjustment of resistance thermometer input range

Connect as shown in “18.4 Connection (2) In case of the resistance thermometer input”.

In case of the KR21\*0, execute the adjustment by inputting the resistance value for the adjustment range of each channels of CH2, CH5, and CH11.

In case of the KR21\*1, execute the adjustment by inputting the resistance value for the adjustment range of CH2.

- (1) Select “Go” at the range to be adjusted, and press the ENTER key.
- (2) Since the window indicating the resistance value for inputting is displayed, input its value to this recorder.
- (3) Adjust the zero point.  
(Example) For the adjustment of the Pt150 range
  - Input the resistance of 100Ω with the standard variable resistor.
- (4) After inputting the zero point for about 5 seconds, press the ENTER key.
- (5) Adjust the span point.  
(Example) For the adjustment of the Pt150 range
  - Input the resistance of 157.33Ω with the standard variable resistor.
- (6) After inputting the span point for about 5 seconds, press the ENTER key.
- (7) After the adjustment of the span point, the screen is returned to the calibration screen for all ranges.
- (8) Repeat from (1) to (6) for the adjustment of other ranges.
- (9) In case of the KR21\*0, after adjustment of each channels of CH2, CH5, CH11, press the ESC key for retuning settings menu screen. In case of KR21\*1, after adjustment of CH2, press the ESC key for retuning settings menu screen. When the channel to be calibrated is kept being open, the adjustment at this channel is not performed.

### 18.5.4 Adjustment of thermocouple input range...Adjustment of the reference junction compensation (RJO °C)

#### Remarks

After the adjustment of the DC voltage input range, execute the adjustment of the thermocouple input range. If the adjustment of the DC voltage input range is performed after the adjustment of the thermocouple input range, the adjustment results are influenced.

Connect as shown in “18.4 Connection (3) In case of the thermocouple input”. Execute the adjustment by connecting the thermocouple for adjusting to each of the CH1, CH6 and CH12 terminals.

- (1) Before moving to the calibration screen, set the input of the CH1, CH6 and CH12 terminals to the followings.  
(Refer to “13.2.1 Setting contents”.)

| Range type | Thermocouple connected  |
|------------|---|
| Range      | Set 1 for the decimal point position of the range setting value.<br>Recommendation: Measuring range of which the reference range is $\pm 13.8\text{mV}$ and the display resolution becomes $0.1^\circ\text{C}$ (Refer to “20 Specifications ○Measuring Range, Accuracy Rating and Display Resolution”.) |
| RJ         | Internal  |
| Burnout    | None  |

(2) Select “Go” at the range of RJ0°C on the calibration screen, and press the ENTER key.

■ Adjustment screen of KR21\*0

| Group1 |        | Real trend |      | Rem. 7.2day |       | 2007/05/16 |       | 17:40:24 |  |
|--------|--------|------------|------|-------------|-------|------------|-------|----------|--|
| Range  |        | Zero       |      |             | Span  |            |       |          |  |
| 27.6mV | Go CLR | -12        | -32  | 6           | 26511 | 26554      | 26572 |          |  |
| 55.2mV | Go CLR | -3         | -13  | 5           | 22731 | 22779      | 22775 |          |  |
| 69mV   | Go CLR | -2         | -12  | 5           | 25633 | 25689      | 25679 |          |  |
| 200mV  | Go CLR | 1          | -3   | 4           | 25655 | 25722      | 25714 |          |  |
| 500mV  | Go CLR | 2          | 0    | 5           | 26720 | 26771      | 26768 |          |  |
| 2V     | Go CLR | 3          | 1    | 5           | 26200 | 26218      | 26226 |          |  |
| 5V     | Go CLR | -5         | -15  | 7           | 26080 | 26133      | 26120 |          |  |
| 10V    | Go CLR | 1          | -3   | 5           | 16690 | 16727      | 16720 |          |  |
| 20V    | Go CLR | 2          | -2   | 5           | 25395 | 25455      | 25437 |          |  |
| 50V    | Go CLR | 3          | 0    | 5           | 26451 | 26492      | 26478 |          |  |
| Pt150  | Go CLR | -52        | -100 | -76         | 23459 | 23515      | 23533 |          |  |
| Pt300  | Go CLR | -17        | -39  | -27         | 18783 | 18860      | 18873 |          |  |
| Pt850  | Go CLR | -3         | -10  | -5          | 15449 | 15505      | 15519 |          |  |
| RJ0°C  | Go CLR | -1         | -1   | -1          | ---   | ---        | ---   |          |  |

■ Adjustment screen of KR21\*1

| Group1 |        | Real trend |    | 1sec |      | 2007/05/16 |       | 17:39:45 |  |
|--------|--------|------------|----|------|------|------------|-------|----------|--|
| Range  |        | Zero       |    |      | Span |            |       |          |  |
| 27.6mV | Go CLR |            |    |      | -12  |            | 26511 |          |  |
| 55.2mV | Go CLR |            |    |      | -3   |            | 22731 |          |  |
| 69mV   | Go CLR |            |    |      | -2   |            | 25633 |          |  |
| 200mV  | Go CLR |            |    |      | 1    |            | 25655 |          |  |
| 500mV  | Go CLR |            |    |      | 2    |            | 26720 |          |  |
| 2V     | Go CLR |            |    |      | 3    |            | 26200 |          |  |
| 5V     | Go CLR |            |    |      | -5   |            | 26080 |          |  |
| 10V    | Go CLR |            |    |      | 1    |            | 16690 |          |  |
| 20V    | Go CLR |            |    |      | 2    |            | 25395 |          |  |
| 50V    | Go CLR |            |    |      | 3    |            | 26451 |          |  |
| Pt150  | Go CLR |            |    |      | -52  |            | 23459 |          |  |
| Pt300  | Go CLR |            |    |      | -17  |            | 18783 |          |  |
| Pt850  | Go CLR |            |    |      | -3   |            | 15449 |          |  |
| RJ0°C  | Go CLR | -1         | -1 | -1   | ---  | ---        | ---   |          |  |

(3) After about 30 seconds passed, press the ENTER key.

| Group1 |  | Real trend |  | 1sec |       | 2006/06/09 |  | 11:47:04 |  |
|--------|--|------------|--|------|-------|------------|--|----------|--|
| RJ0°C  |  | Zero       |  |      | 0.0°C |            |  |          |  |

(4) After adjustment, the screen is returned to the calibration screen for all ranges.

(5) When the adjustments are completed, press the ESC key to return to the menu screen.

**Remarks**

- When the input to this recorder was wrong or some inconvenience occurred, try to execute the scale calibration again.
- When select the “CLR” button and press the ENTER key on the calibration screen, the adjustment data are cleared and returned to the default data set at the factory.

# 19 Recommended parts replacement interval

It is recommended to exchange parts periodically as preventive maintenance for using this recorder under good conditions for a long time

## Warning

For replacing parts, ask the service personnel authorized by CHINO. Otherwise, this instrument may not recover properly and also accident may occur.  
Contact your local CHINO's sales agent to perform parts replacement.

### 19.1 Operating Conditions

The reference of the parts exchange intervals is under the following standard conditions. The intervals become shorter if environmental conditions are worse than the standard conditions.

| Items          | Conditions  |
|----------------|-------------|
| Temperature    | 20 to 25°C  |
| Humidity       | 20 to 80%RH |
| Operation time | 8 hours/day |
| Corrosive gas  | Not existed |

| Items  | Conditions   |
|--------|--|
| Others | 1) A place without dust, moisture or oily smoke<br>2) A place without vibrations or shocks<br>3) A place where the operation is not adversely affected |

### 19.2 Reference of Parts Replacement Intervals

| Part name                           | Reference of exchange | Remarks   |
|-------------------------------------|-----------------------|---|
| Power supply unit                   | 5 years               | At the ambient temperature of 25°C                      |
| LCD                                 | 3 years               | *   |
| Keypad                              | 5 years               |   |
| Relay (For mechanical alarm output) | 70,000 times          | Resistance load<br>(Less than the rated contact rating) |
|                                     | 20,000 times          | Inductive load<br>(Less than the rated contact rating)  |
| Lithium battery                     | 5 years               |   |

\* When the LCD reduces its brightness to half, exchange it. The reduction of brightness differs depending on the usage conditions.  
The replacement interval can be extended by using the screen saver function or by setting the brightness control small.



# 20 Troubleshooting

Troubleshooting methods are shown by symptoms. Read corresponding symptom items.

## 1. Not working

| Check   | Causes and remedial measures                             |
|---|--|
| 1) Check if power is supplied to power terminals            | Turn on the external source power supply.                |
| 2) Check if the power supply is as specified                | Feed power supply as specified (100 to 240 VAC 50/60Hz). |
| 3) Check if connections to power terminals are correct.     | Connect the cable to power terminals (L, N) correctly.   |
| 4) POWER switch is not turned ON.                           | Turn ON the POWER switch.                                |
| 5) Try turning off and on the external source power supply. |  |

## 2. Abnormal measurement

| Symptoms   | Causes and remedial measures   |
|--|--|
| 1) Measured values unstable                                    | <ul style="list-style-type: none"> <li>●Check measuring terminals for looseness.</li> <li>●Check if the input signal is unstable.</li> </ul>   |
| 2) An error occurs   | <ul style="list-style-type: none"> <li>●Check if the input signal is correct.</li> <li>●Check if extension wire is connected to input terminals. (Thermocouple input only)</li> <li>●Check input value, if error found, perform calibration with reference to Adjustment (par. 16).</li> </ul> |
| 3) Influences by ambient temperature (Thermocouple input only) | <ul style="list-style-type: none"> <li>●Check if the terminal cover is mounted</li> </ul>  |

### When problem cannot be solved

If problem cannot be solved by performing the troubleshooting, contact your sales agent or CHINO with information of

1. Model, 2. Serial No., 3. Description of problem, 4. Other notes.

When the instrument need to repaire, underdatnd the following before having it repaired.

The data of internal memory may be deleted during repairing.

Backup the data to CF card before having the instrument repaired. We are not responsible for the lost or damaged data.

# 21 Specifications

## ■ General Specifications

Rated power voltage: 100-240 VAC, 50/60 Hz  
(Universal power supply)

Power consumption: 50VA MAX

Operating conditions:

- Reference operating condition
  - ... Ambient temperature/humidity range  
21 to 25°C 45 to 65%RH
  - Power voltage 100 VAC  $\pm 1\%$
  - Power frequency 50/60 Hz  $\pm 0.5\%$
  - Attitude left/right 0° , forward tilting 0° backward  
tilting 0°
  - Warm-up time: 30 minutes or more
- Normal operating condition
  - ... Ambient temperature/humidity range  
0 to 50°C, 20 to 80%RH
  - Power voltage 90 to 264 VAC
  - Power frequency 50/60 Hz  $\pm 2\%$
  - Attitude left/right 0° forward tilting 0°  
backward tilting 0° to 20°
- Transportation condition,
  - ... In the packed condition on shipment from the factory
  - Ambient temperature/humidity range  
-20 to +60°C, 5 to 90%RH (no dew condensation)
  - Vibrations 10 to 60 Hz, less than 0.5 G
  - Impact Less than 40 G
- Storage condition,
  - ... Ambient temperature/humidity range  
-20 to 60°C, 5 to 90% RH (no dew condensation)

Power failure protection:

FLASH memory and SRAM stores the setting.  
A FLASH memory stores the data.  
A lithium battery backs up the clock and parameter  
RAM for more than 5 years (provided that the daily  
operating hours is longer than 8 hours).

Insulation resistance:

Between secondary and protective conductor terminals  
..... More than 20 M $\Omega$  at 500 VDC

Between primary and protective conductor terminals  
..... More than 20 M $\Omega$  at 500 V DC

Between primary and secondary terminals  
..... More than 20 M $\Omega$  at 500 VDC

Between alarm output (mechanical relay) and other  
secondary terminal  
..... More than 20 M $\Omega$  at 500 VDC

Dielectric strength:

Between secondary and protective conductor terminals  
..... 1 minute at 500 V AC

Between primary and protective conductor terminals  
..... 1 minute at 1500 V AC

Between primary and secondary terminals  
..... 1 minute at 2300 V AC

\*\*Primary terminals: Power terminals, alarm output terminals  
Secondary terminals: Input terminals, digital input terminals,  
communication terminals

Case assembly material: Door frame.....ABS resin  
Case and power supply material.....Steel

Color: Door frame..... Black (Equivalent to Munsell N3.0),  
Case.....Gray (Equivalent to Munsell N7.0)

Weight: Approx. 2.2 kg

Mounting: Panel mounting

Clock accuracy:  $\pm 2$  minutes per 30 days (excluding errors  
due to power ON/OFF under the reference operating  
conditions.)

Terminal screws: Power terminal.....M4.0  
Protective conductor terminal.....M4.0  
Input terminals.....M3.5  
Alarm output terminals.....M3.5  
Digital input terminal.....M3.5  
Communication terminals.....M4.0

## ■ Standards

CE marking: EN61326-1: 2006 Class A  
EN61010-1: 2001

IP: IEC529 IP65 (front part) compliance

## ■ Input Specifications

Measuring points: KR2160, 2161... 6 points,  
KR2120, 2121...12 points

Input types: Universal

DC voltage...  $\pm 13.8$  mV,  $\pm 27.6$  mV,  
 $\pm 69.0$  mV,  $\pm 200$  mV,  
 $\pm 500$  mV,  $\pm 2$ V,  $\pm 5$ V\*,  
 $\pm 10$ V\*,  $\pm 20$ V\*,  $\pm 50$ V\*  
(\* With built-in shunt resistors)

DC current... Available by adding external shunt resistor  
T/C... B, R, S, K, E, J, T, N,  
NiMo-Ni, CR-AuFe,  
PtRh40-PtRh20,  
WRe5-WRe26, W-WRe26,  
Platinel II, U, L

RTD... Pt100,  
JPt100, Pt50, Pt-Co

Range setup: Setting of input types and ranges by key  
operation.

The measuring range is selected automatically  
according to the set range.

Scale setup: Setting of minimum values, maximum values  
and engineering units by key operation.

Accuracy rating: See table of inputs.

Temperature drift:  $\pm 0.01\%$  of full scale/°C [Other input types  
than the resistance thermometer inputs are  
converted into the reference range (see the  
Accuracy Rating table)]

Sampling rate: KR2160...0.1 second / 6 points  
KR2120...0.1 seconds / 12 points  
KR2161...0.3 second / 6 points  
KR2121...0.3 second / 12 points

\*\*When less than 1 second is set the recording interval at  
KR2161, 2121, sampling rate is 0.1 second / 4 points.

\*\*internal processes (alarm judgment, computation etc.) are  
performed 0.1 seconds cycle.

Reference junction (RJ) compensation accuracy:

K, E, J, T, N, Platinel II ... Maximum  $\pm 0.5^\circ\text{C}$   
R, S, NiMo-Ni  
CR-AuFe  
WRe5-WRe26,  
W-WRe26, U, L ..... Maximum  $\pm 1.0^\circ\text{C}$

(The above errors are added to the accuracy ratings for the  
internal reference junction compensation)

Input resolution: Approx. 1/32,000 (converted into reference  
range)

Burnout: Signal disconnection detection for thermocouple and  
resistance thermometer inputs.

Up-scale burnout, down-scale burnout or burnout  
disabled can be selected for each input.

Allowable signal source resistance:

- Thermocouple inputs (burnout disabled), DC voltage inputs (max. ±2 V) ..... Less than 1 KΩ
- DC voltage inputs (±5 to 50 V) ...Less than 100 Ω
- Resistance thermometer inputs (Pt100, JPt100) ... Less than 10 Ω per wire -- common for 3 wires

Input resistance: Thermocouple input

- ... Approx. 1 MΩ
- DC voltage input ... Approx. 1 MΩ at less than ±2 V,

Maximum input voltage:

- Thermocouple inputs (burnout disabled), DC voltage inputs (max. ±2V) Maximum ±10V DC
- DC voltage inputs (±5 to 50 V) Maximum ±60V DC
- Thermocouple inputs (burnout enabled), resistance thermometer inputs Maximum ±6V DC

Maximum common mode voltage: 30V AC

Common mode rejection ratio: Minimum 120dB (50 or 60Hz)

Series mode rejection ratio: Minimum 50dB (50 or 60Hz)  
 However, when it contains a thing for the signal and the peak value of the noise is equal to or less than 1.5 times the standard range.

## ■Recording Specifications

Internal memory: 4MB

Recording cycle:

|        |   |
|--------|---|
| Second | 0.1, 0.2, 0.5, 1, 2, 3, 5, 10, 15, 20, 30 sec |
| Minute | 1, 2, 3, 5, 10, 15, 20, 30, 60 min            |

(Caution): When set less than 0.5 seconds (0.1-0.5 seconds) to the recording cycle at KR2161/2121, input channel number is automatically 4 points.

Recording data:

- Measured data  
Group name, recording start date/time, recording cycle, measured data, alarm data, maker text
- Programmed parameters All parameters

Recording measured data: 4-byte binary/1 data  
 (Recording maximum and minimum value 6 byte/1 data)

Recording into internal memory:

:\*The following conditions can be selected.

- Key operations
- Trigger signals (alarm activation)
- Start/end by day and time

\*Pre-triggering recording available with the key operations and trigger signals

Pre-triggering measuring count =950 data

\*Recording cycle can be programmed for each file

Memory usage display:

The amount of memory used in each file is displayed on the operation screens by icon.

External memory: • CF card  
 (FAT16, FAT32 formatted)

## ■Display Specifications

Display: 5.6-inch TFT color LCD  
 (316x234 dots: 111.36mmX83.52mm)

Trend display colors: 12 colors (selectable)

Operation screens:

Screens are switched with the DISP. Key, scroll key and ENTER key.  
 Screens of 5 groups can be switched except for the Alarm Summary screen (max. 44 channels/1 group).

• Trend screens:

One of the Real-time Trend, Historical Trend or Dual Trend displays can be selected.  
 (scale plate and pointer displays) Vertical or horizontal orientation selectable. Data display enabled or disabled selectable. Scrolling available.

• Bar graph screen...Data display enabled or disabled selectable.

• Data screen... (Data + Tag + Engineering unit + Alarm activated status)

• Alarm summary screen: Current alarm output status + alarm log (Channel, level, alarm event time)

Skipping: On the Trend and Data screens, the channels to be skipped in display can be set for each group.

Scrolling: On the Historical Trend screens, previous data can be referred with the cursor operation.

- Historical Trend...Entire Memory file area
- Dual Trend...Enables on the historical trend screen only.

Display (Historical Trend): Historical data is displayed by specifying a file.  
 Data logging is continued.

\* Display by scrolling or by time specified.

\* Enables to display from a CF memory card.

Data search (Historical Trend):

Historical trend display by selecting from alarm display, marker list

Marker display: Marker can be displayed on the real-trend screen by the key operation or by digital input and stored in a message data file.

※ Pre-registration of marker text  
 (Maximum 50 texts, Maximum 30 characters / Text).

Display updating interval: Same as storing interval

LCD saver: When no key is operated for the specified period of time, the back-light is OFF. The period can be set from 1-60 minutes..

## ■Programming/Operation Specifications

Key types: 14

START, STOP, SCROLL, CURSOR, MARKER, DISP, HOME, MENU, ESC, ENTER, Direction key: right, left, up, down

HOME setting:

- Input parameter setting
- Storage interval setting
- Specifications confirmation

MENU setting:

- Input and arithmetic setting
- Display setting
- Alarm setting
- File setting
- Totalizer reset setting
- Schedule setting
- Marker text setting
- Memory operation
- Network setting
- System setting

## ■ Alarm Specifications

Number of alarms that can be set: Up to 4 alarms/channel

Alarm types: Upper limit, lower limit, differential higher limit, differential lower limit

Alarm memory: Stores alarm event/cancellation time, alarm types

\* Storage of latest 200 common channels

Alarm output (Option): 12 points ("a" contact)  
 6points ("c" contact)

## ○ Measuring Range, Accuracy Rating and Display Resolution

Note) For the accuracy under the reference operation condition and for thermocouple inputs (internal RJ), the reference junction compensation accuracy is not included.

| Input type    | Measuring range    | Reference range    | Accuracy rating   | Display resolution |        |
|---------------|--------------------|--------------------|-------------------|--------------------|--------|
| THERMOCOUPLE  | K                  | -200.0 to 300.0 °C | ±13.8 mV          | 0.1 °C             |        |
|               |                    | -200.0 to 600.0 °C | ±27.6 mV          | 0.1 °C             |        |
|               |                    | -200 to 1370 °C    | ±69.0 mV          | 1 °C               |        |
|               | E                  | -200.0 to 200.0 °C | ±13.8 mV          | 0.1 °C             |        |
|               |                    | -200.0 to 350.0 °C | ±27.6 mV          | 0.1 °C             |        |
|               |                    | -200 to 900 °C     | ±69.0 mV          | 1 °C               |        |
|               | J                  | -200.0 to 250.0 °C | ±13.8 mV          | 0.1 °C             |        |
|               |                    | -200.0 to 500.0 °C | ±27.6 mV          | 0.1 °C             |        |
|               | T                  | -200 to 1200 °C    | ±69.0 mV          | ±0.1%<br>±1digit   | 1 °C   |
|               |                    | -200.0 to 250.0 °C | ±13.8 mV          | 0.1 °C             | 0.1 °C |
|               | R                  | -200.0 to 400.0 °C | ±27.6 mV          | 0.1 °C             | 0.1 °C |
|               |                    | 0 to 1200 °C       | ±13.8 mV          | 1 °C               | 1 °C   |
|               | S                  | 0 to 1760 °C       | ±27.6 mV          | 1 °C               | 1 °C   |
|               |                    | 0 to 1300 °C       | ±13.8 mV          | 1 °C               | 1 °C   |
|               | B                  | 0 to 1760 °C       | ±27.6 mV          | 1 °C               | 1 °C   |
|               |                    | 0 to 1820 °C       | ±13.8 mV          | 1 °C               | 1 °C   |
|               | N                  | -200.0 to 400.0 °C | ±13.8 mV          | 0.1 °C             | 0.1 °C |
|               |                    | -200.0 to 750.0 °C | ±27.6 mV          | 0.1 °C             | 0.1 °C |
|               |                    | -200 to 1300 °C    | ±69.0 mV          | ±0.15%<br>±1digit  | 1 °C   |
|               | W-WRe26            | 0 to 2315 °C       | ±69.0 mV          | 1 °C               | 1 °C   |
| WRe5-WRe26    | 0 to 2315 °C       | ±69.0 mV           | 1 °C              | 1 °C               |        |
| PtRh40-PtRh20 | 0 to 1888 °C       | ±13.8 mV           | 1 °C              | 1 °C               |        |
| NiMo-Ni       | -50.0 to 290.0 °C  | ±13.8 mV           | 0.1 °C            | 0.1 °C             |        |
|               | -50.0 to 600.0 °C  | ±27.6 mV           | 0.1 °C            | 0.1 °C             |        |
|               | -50 to 1310 °C     | ±69.0 mV           | ±0.2%<br>±1digit  | 1 °C               |        |
| CR-AuFe       | 0.0 to 280.0 K     | ±13.8 mV           | 0.1 K             | 0.1 K              |        |
| Platinel II   | 0.0 to 350.0 °C    | ±13.8 mV           | 0.1 °C            | 0.1 °C             |        |
|               | 0.0 to 650.0 °C    | ±27.6 mV           | 0.1 °C            | 0.1 °C             |        |
|               | 0 to 1395 °C       | ±69.0 mV           | ±0.15%<br>±1digit | 1 °C               |        |
| U             | -200.0 to 250.0 °C | ±13.8 mV           | 0.1 °C            | 0.1 °C             |        |
|               | -200.0 to 500.0 °C | ±27.6 mV           | 0.1 °C            | 0.1 °C             |        |
|               | -200.0 to 600.0 °C | ±69.0 mV           | ±0.15%<br>±1digit | 0.1 °C             |        |
| L             | -200.0 to 250.0 °C | ±13.8 mV           | 0.1 °C            | 0.1 °C             |        |
|               | -200.0 to 500.0 °C | ±27.6 mV           | 0.1 °C            | 0.1 °C             |        |
|               | -200 to 900 °C     | ±69.0 mV           | ±0.1%<br>±1digit  | 1 °C               |        |

K, E, J, T, R, S, B, N: IEC584, JIS C1602-1995,  
U (Cu-CuNi), (Fe-CuNi): DIN43710  
W-WRe26, WRe5-WRe26, PtRh40,  
PtRh20, NiMo-Ni, CR-AuFe, PlatinelII: ASTM

| Input range            | Measuring range    | Reference range    | Accuracy rating   | Display Resolution |        |
|------------------------|--------------------|--------------------|-------------------|--------------------|--------|
| DC Voltage             | -13.80 to 13.80 mV | ±13.8 mV           | ±0.1%<br>±1digit  | 10µV               |        |
|                        | -27.60 to 27.60 mV | ±27.6 mV           |                   | 10µV               |        |
|                        | -69.00 to 69.00 mV | ±69.0 mV           |                   | 10µV               |        |
|                        | -200.0 to 200.0 mV | ±200.0 mV          |                   | 100µV              |        |
|                        | -500.0 to 500.0 mV | ±500.0 mV          |                   | 100µV              |        |
|                        | -2.000 to 2.000 V  | ±2 V               |                   | 1 mV               |        |
|                        | -5.000 to 5.000 V  | ±5 V               |                   | 1 mV               |        |
|                        | -10.00 to 10.00 V  | ±10 V              |                   | 10 mV              |        |
|                        | -20.00 to 20.00 V  | ±20 V              |                   | 10 mV              |        |
|                        | -50.00 to 50.00 V  | ±50 V              |                   | 10 mV              |        |
| Resistance thermometer | Pt100 (JIS'97)     | -140.0 to 150.0 °C | 160 Ω             | ±0.15%<br>±1digit  | 0.1 °C |
|                        |                    | -200.0 to 300.0 °C | 220 Ω             | ±0.1%<br>±1digit   | 0.1 °C |
|                        |                    | -200.0 to 850.0 °C | 400 Ω             | ±0.1%<br>±1digit   | 0.1 °C |
|                        | JPt 100            | -140.0 to 150.0°C  | 160 Ω             | ±0.15%<br>±1digit  | 0.1°C  |
|                        |                    | -200.0 to 300.0°C  | 220 Ω             |                    |        |
|                        |                    | -200.0 to 649.0°C  | 400 Ω             |                    |        |
| Pt50                   | -200.0 to 649.0 °C | 220 Ω              | ±0.1%<br>±1digit  | 0.1 °C             |        |
| Pt-Co                  | 4.0 to 374.0 K     | 220 Ω              | ±0.15%<br>±1digit | 0.1 K              |        |

P t 1 0 0 : IEC751 (1995),  
JIS C1604-1997  
JPt100: JIS C1604-1981,  
JIS C1606-1989  
P t 5 0 : JIS C1604-1981

## ○ Exception of accuracy rating

| Input range   | Measuring range | Accuracy rating |
|---------------|-----------------|-----------------|
| K, E, J, T, L | -200 to 0 °C    | ±0.2%±1digit    |
| R, S          | 0 to 400 °C     | ±0.2%±1digit    |
| B             | 0 to 400 °C     | Not specified   |
|               | 400 to 800 °C   | ±0.15%±1digit   |
| N, U          | -200 to 0 °C    | ±0.3%±1digit    |
| W-WRe26       | 0 to 100 °C     | ±4%±1digit      |
|               | 100 to 400 °C   | ±0.5%±1digit    |
| PtRh20-PtRh5  | 0 to 100 °C     | ±4%±1digit      |
|               | 100 to 400 °C   | ±0.5%±1digit    |
| PtRh40-PtRh20 | 0 to 300 °C     | ±1.5%±1digit    |
|               | 300 to 800 °C   | ±0.8%±1digit    |
| CR-AuFe       | 0 to 20 K       | ±0.5%±1digit    |
|               | 20 to 50 K      | ±0.3%±1digit    |
| Pt100('97)    | 700 to 850 °C   | ±0.15%±1digit   |
| Pt-Co         | 4 to 50 K       | ±0.3%±1digit    |

# Appendix A. Report Application (Sample)

## Note

This application is a sample application. Inquiries about usage and malfunction cannot be accepted. Please understand it before using.

Reports such as daily/monthly reports can be created by using the report application included in the CD attached. Installation operations on the PC are required for using this application. Moreover, Excel (97 or later) should be installed.

In this software, the editing is executed on the data acquired by this recorder and imported to a PC. CSV formatted file can be used for the data.

## A-1 Operation environment

|        |                               |
|--------|-------------------------------|
| OS     | Windows98, Me Windows2000, XP |
| CPU    | Pentium300MHz or higher       |
| Memory | 64MB or more                  |
| Others | Excel 97 (Microsoft) or later |

## A-2 Installation method

Insert the attached CDROM in the CD drive of the PC in which the report application is to be used, and run the “setup.exe” in the “report (English)” folder. Follow the instructions on the screen to install this application.

## A-3 Uninstallation method

Open “Add/Remove programs (or Add/Remove applications depending on the OS)” from the control panel and remove the report application.

## A-4 Operation method

### A-4-1 Main screen

When the application is started, the basic screen is displayed. Perform various operations based on this screen.

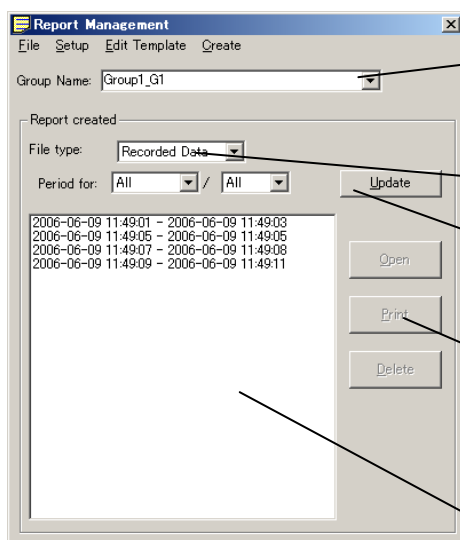

Select the group to be operated. The group names, based on the data of the stored data folder specified by the “Setup”, are registered in the list. Enter the group name with the keyboard when there is no group to be selected.

The created report file with the conditions specified here is displayed in the list box below.

Update the contents from the following list box to the latest status.

Operations such as “Open” “Print” “Delete” can be executed for the file selected in the list box in the left.

The data and time of the report files, in the folder designated, matching with the conditions specified in the above combo box, is displayed in list.

## A-4-2 Menu structure

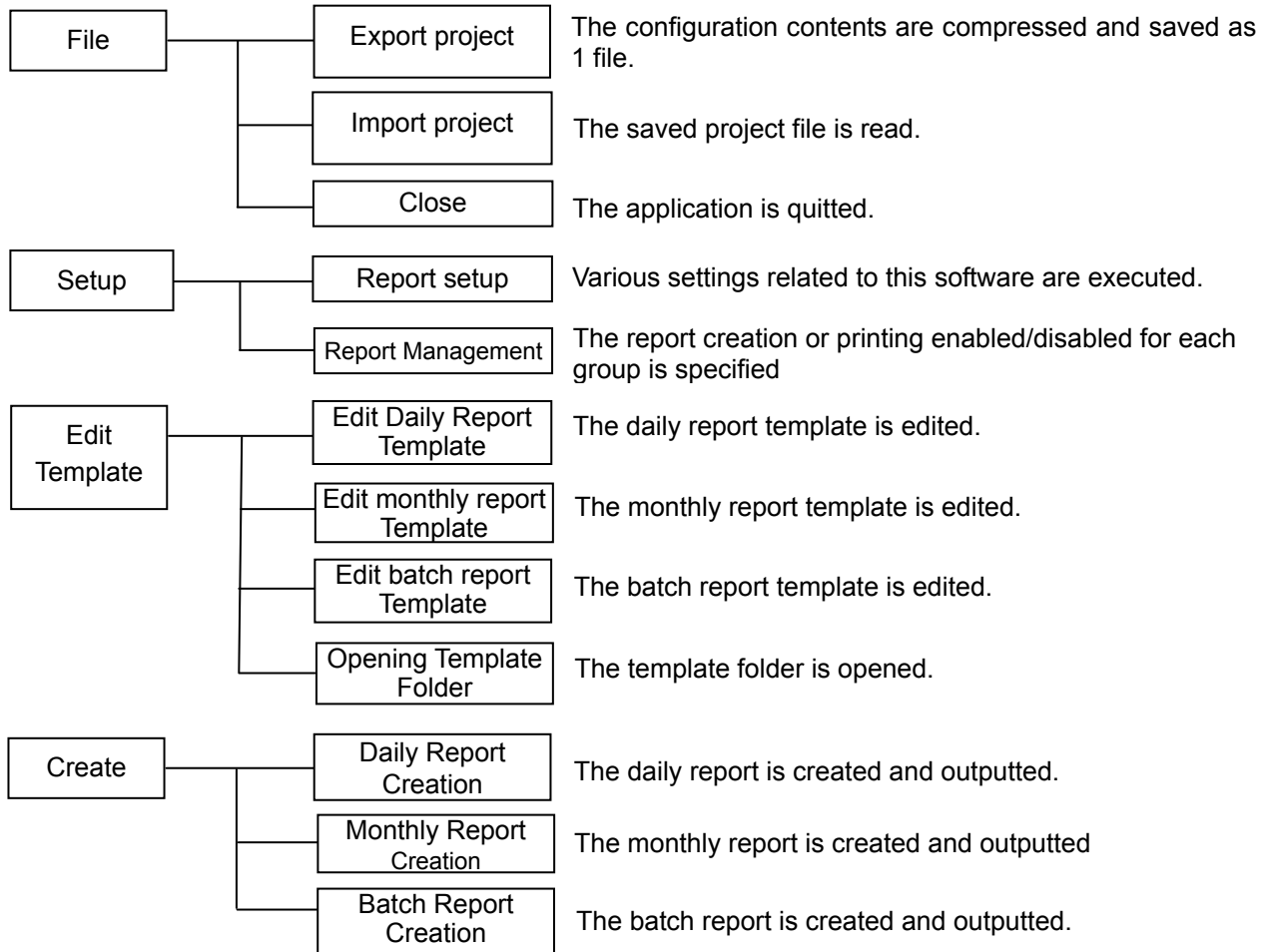

## A-4-3 Exporting Project

Specify the save destination and the file name.

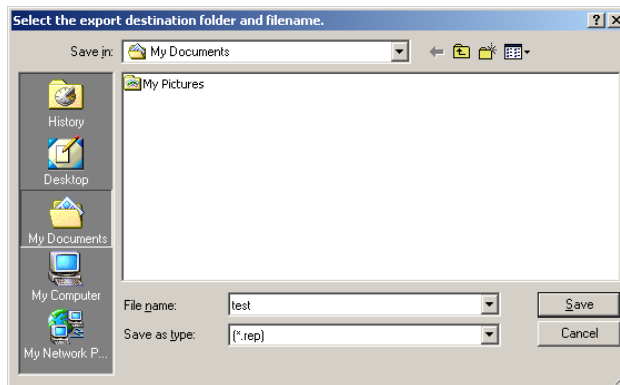

The compressed saving is executed and the file is created.

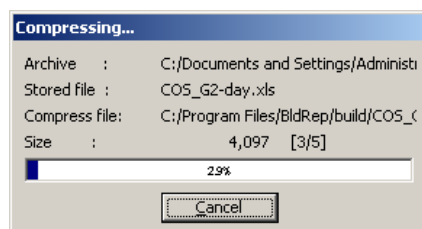

#### A-4-4 Importing project

- ① Confirmation dialog box for overwriting the configuration is displayed. Click the "OK".

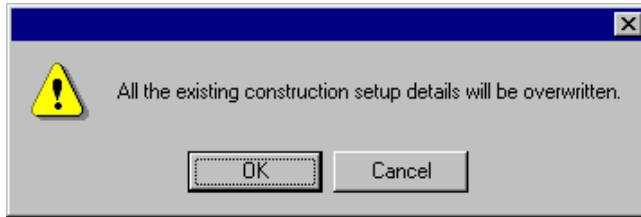

- ② Select the file to be read.

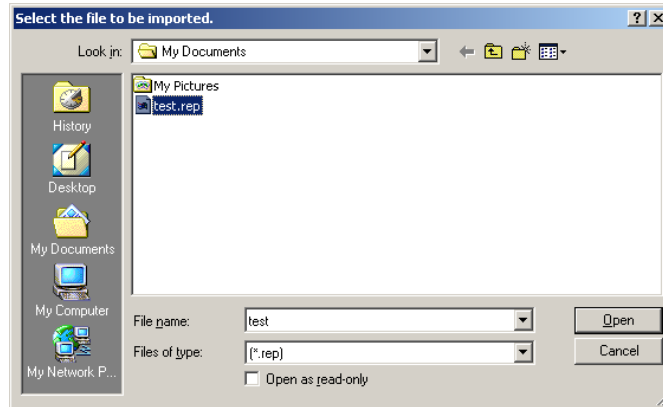

- ③ Read the file.

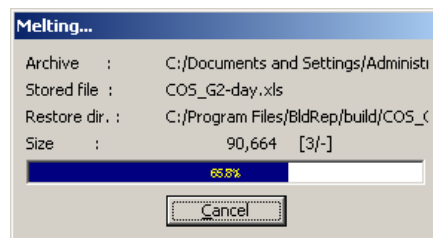

#### A-4-5 Report settings

The setting tables of the Type, Recorded Data, Output, Start Date/Time and password are displayed. The contents of each tab are described below.

(Type)

Select the report type to be used from the following 3 patterns.

- Daily report and Monthly report
- Batch report
- Daily report, Monthly report and Batch report

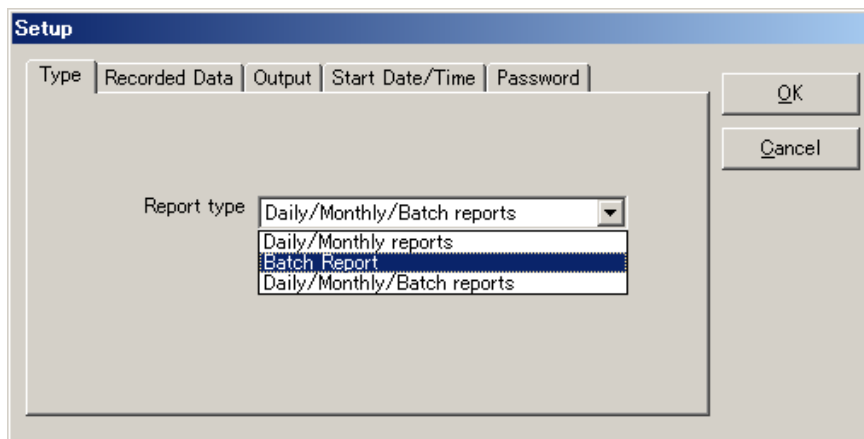

Daily report ... The report is created by compiling the data stored in a day.

Monthly report ... The report is created by compiling the data stored in a month.

Batch report ... The report corresponding to the stored data file.

(Stored data)

Specify the folder in which the stored data is saved. For setting, use the folder selection screen by clicking “Reference”. Copy the file of this recorder to this directory, or specify the data saving directory of the CF card and insert the CF card when the report is created.

Only the CSV formatted file can be used for the stored data. Set the “Save format” to the “CSV” in the file settings of this recorder.

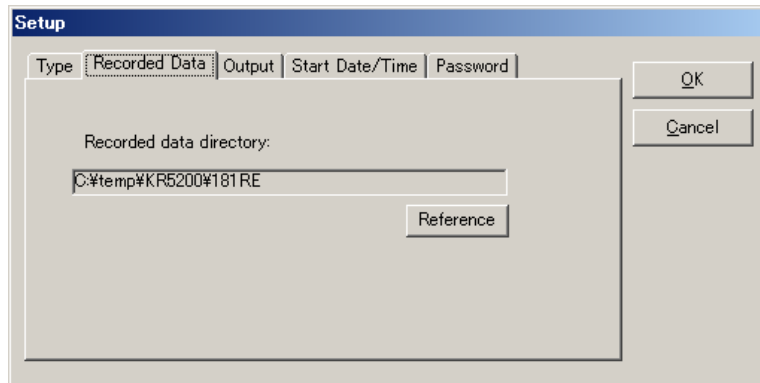

(Output)

Specify the output destination (save destination) of the report file. For setting, use the folder selection screen by clicking “Reference”. The required setting items are displayed by selection at the “Type” tab. The following figure is for the Daily/Monthly reports.

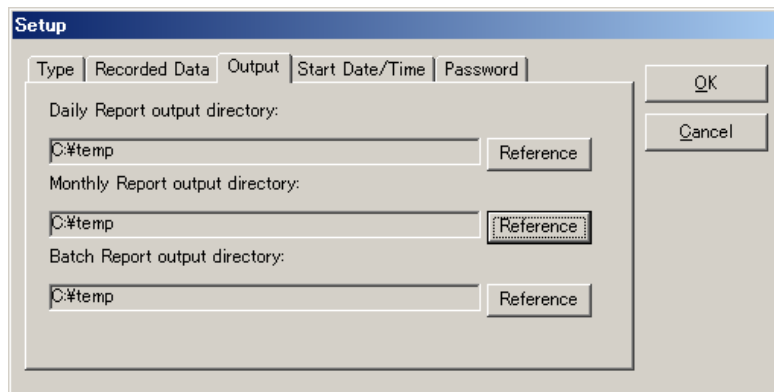



## Settings of KR2000

Set KR2000 as shown below for using the report application.

### (1) File save format

Select the "CSV" for the file save format. This application cannot be used in case of Binary.

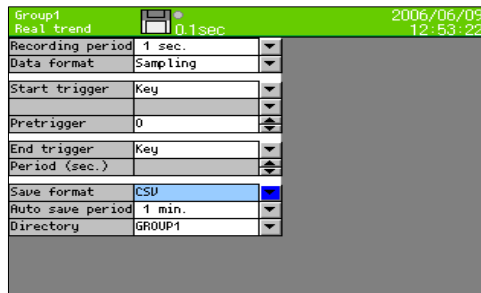

### (2) Schedule settings

When using the daily report, it is convenient if the "Day" is selected with the KR2000 schedule settings, the required day is checked, and set the start and end time is set to the date change time of the daily report because the file is divided at that point.

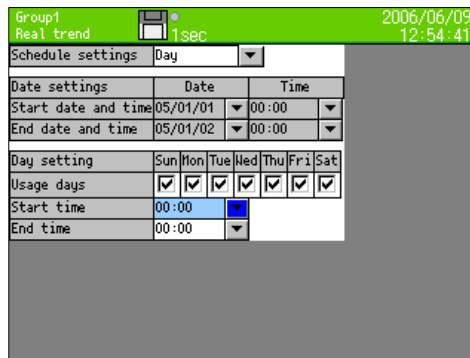

### (Start Date/Time)

Set the starting time of a day for creating the daily report and the starting date in a month for creating the monthly report. With this settings, set the time range for data to be used for creating the daily report or the monthly report.

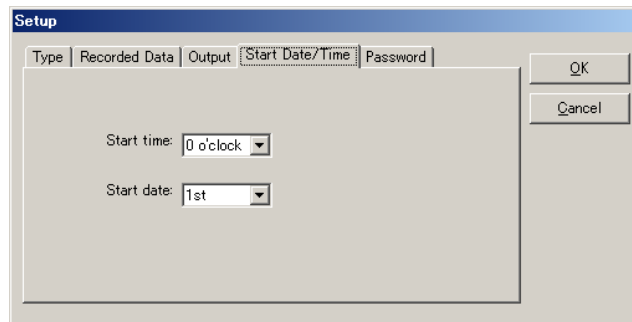

### (Password)

Register the password for locking the report template with. Use the same password for all templates. When the template is locked, the report cannot be created if the password is not entered or a wrong password is entered.

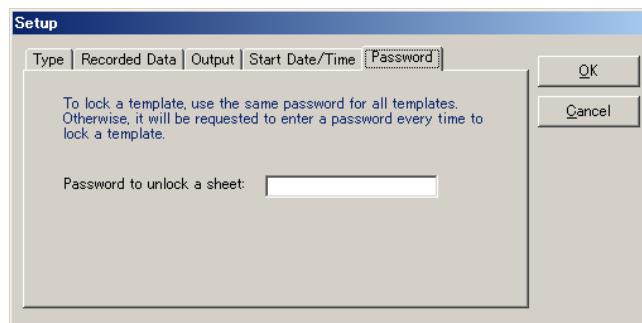

### A-4-6 Report Management

Specify whether each report is created for every group.

Each time each column is clicked, it changes from \* → (Blank) → P. The “— “ indicates that the template is not created. The report is not created if the template is not created.

The report marked with “\*” is created but the report marked with blank is not created. The report marked with “P” is created and then printed out.

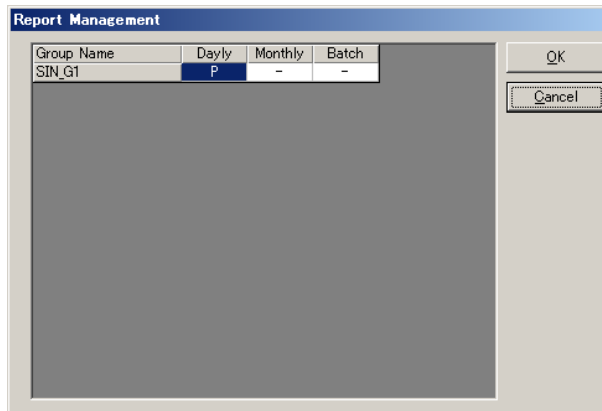

### A-4-7 Edit sheet

The template editing is described in A-5 Edit report template.

### A-4-8 Create daily report

The daily reports of the groups marked with “\*” in the daily report column of the report management is created based on the contents in the daily report template.

1. Specify the period for creating the daily report. Select the start date and the end date.

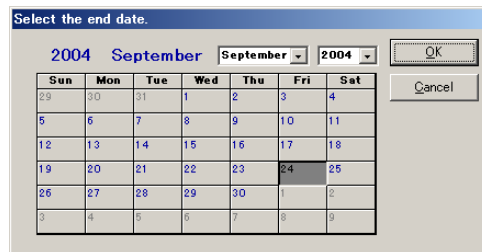

2. The daily report is created after reading the stored data.

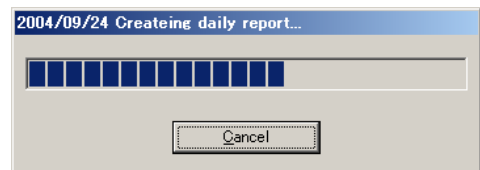

3. After the daily report is created, it is added to the list in the “Report created”.

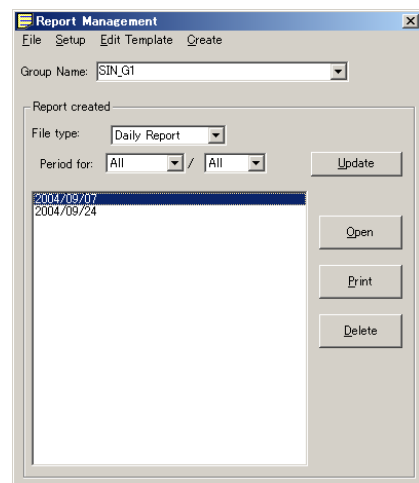

### A-4-9 Monthly report creation

The monthly reports of the groups marked with “\*” in the monthly report column of the report management is created based on the contents in the monthly report template.

1. Specify the period for creating the monthly report. Select the start month and the end month.

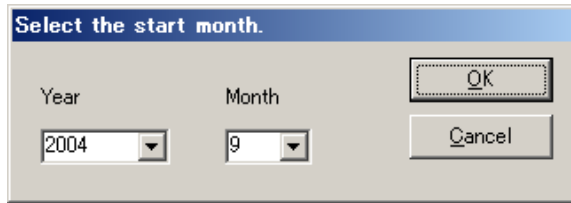

A dialog box titled "Select the start month." with a blue header bar. It contains two dropdown menus: "Year" with "2004" selected and "Month" with "9" selected. There are "OK" and "Cancel" buttons on the right side.

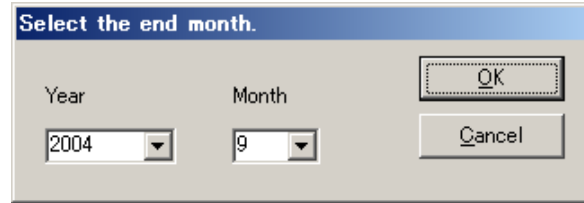

A dialog box titled "Select the end month." with a blue header bar. It contains two dropdown menus: "Year" with "2004" selected and "Month" with "9" selected. There are "OK" and "Cancel" buttons on the right side.

2. The monthly report is created after reading the daily report.

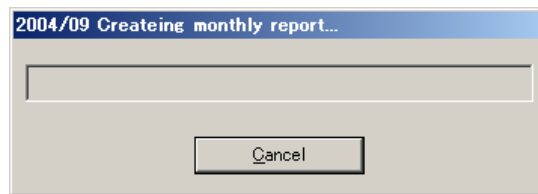

A dialog box titled "2004/09 Creating monthly report..." with a blue header bar. It contains a single empty text input field and a "Cancel" button at the bottom.

3. After the monthly report is created, it is added to the list in the “Report created”.

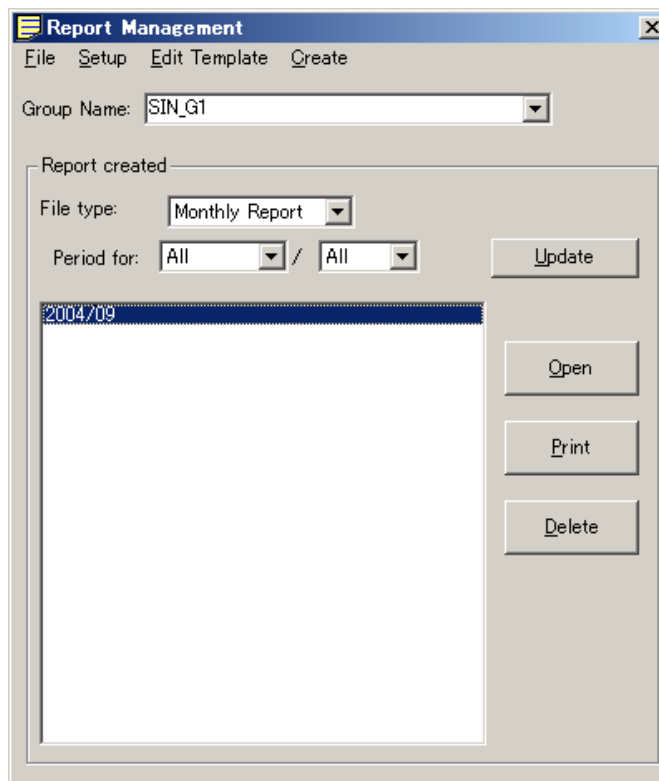

The "Report Management" window has a menu bar with "File", "Setup", "Edit Template", and "Create". The "Group Name" dropdown is set to "SIN\_G1". Under the "Report created" section, the "File type" is "Monthly Report" and the "Period for" is "All / All". There is an "Update" button. A list box shows "2004/09" selected. To the right of the list box are "Open", "Print", and "Delete" buttons.

## A-4-10 Create batch report

1. Select the stored data file for the report.

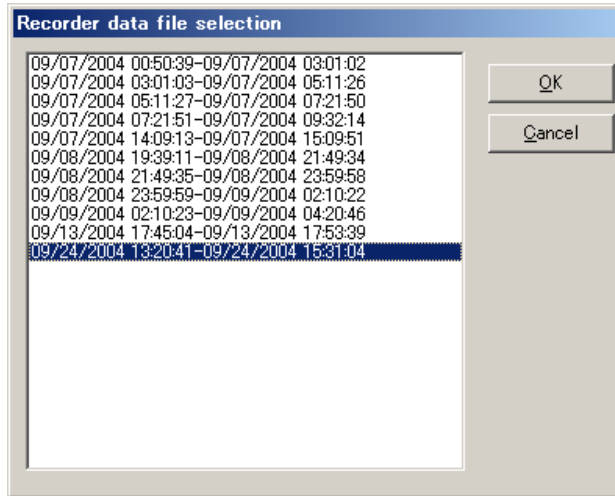

2. The batch report is created after reading the stored data.

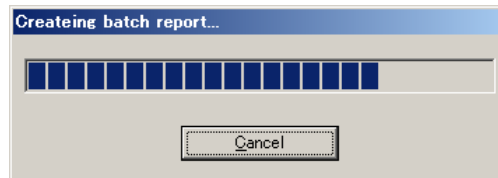

3. After the batch report is created, it is added to the list in the "Report created".

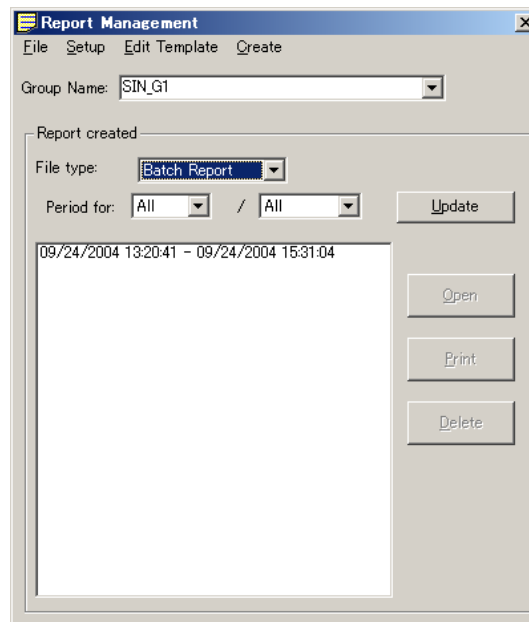

## A-5 Edit Report Template

Each report is created on the respective template. On the template, create frame of table, fonts, formula indicating cell contents, fixed characters, printing-related-settings, etc. beforehand.

### A-5-1 Edit daily report template

The contents created on the “daily report” sheet are outputted as the daily report.

1. Create frames, fixed characters, etc. for the daily report.

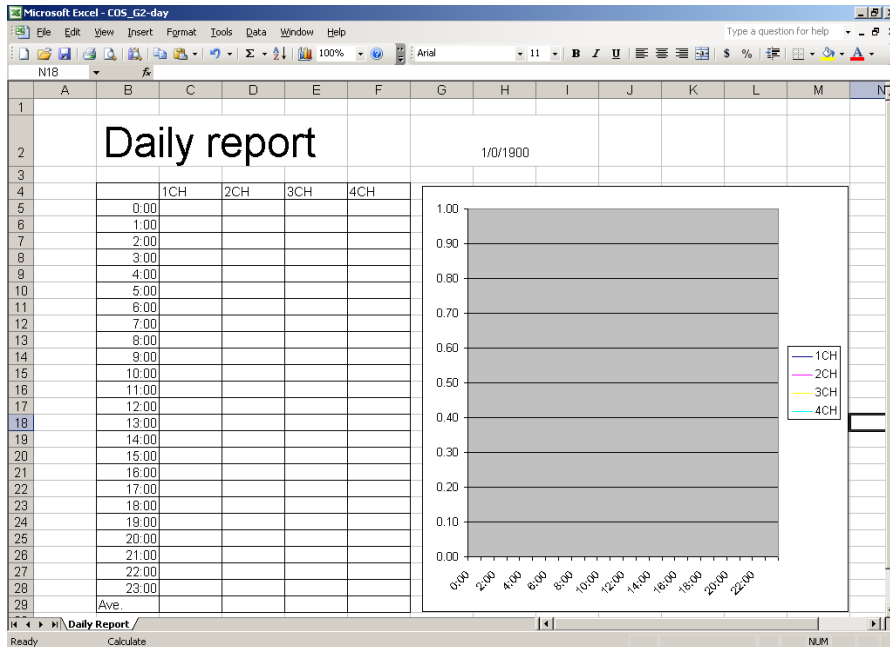

2. Open the input screen by double-clicking on the cell where the data is to be pasted.

Select the function type for the data to be pasted.

Select the data channel. If the “Time stamp” is selected, the time is used in calculation instead of data. Use it for writing the time indication.

Use here for inputting the created contents continuously in the time direction or the channel direction.

Select whether the calculation for average, maximum, etc. is applied to the data in the entire day or is applied to the data in the specified time range.

When this is checked and the calculated result is an error, its result is displayed as a blank instead of an error indication.

3. By clicking the “OK” after setting all items, the formula is written in the cell.

4. After the creation is complete, execute the overwrite-save of the file and quit.

## A-5-2 Edit monthly report template

The contents created on the “monthly report” sheet are outputted as the monthly report.

1. Create frames, fixed characters, etc. for the monthly report.

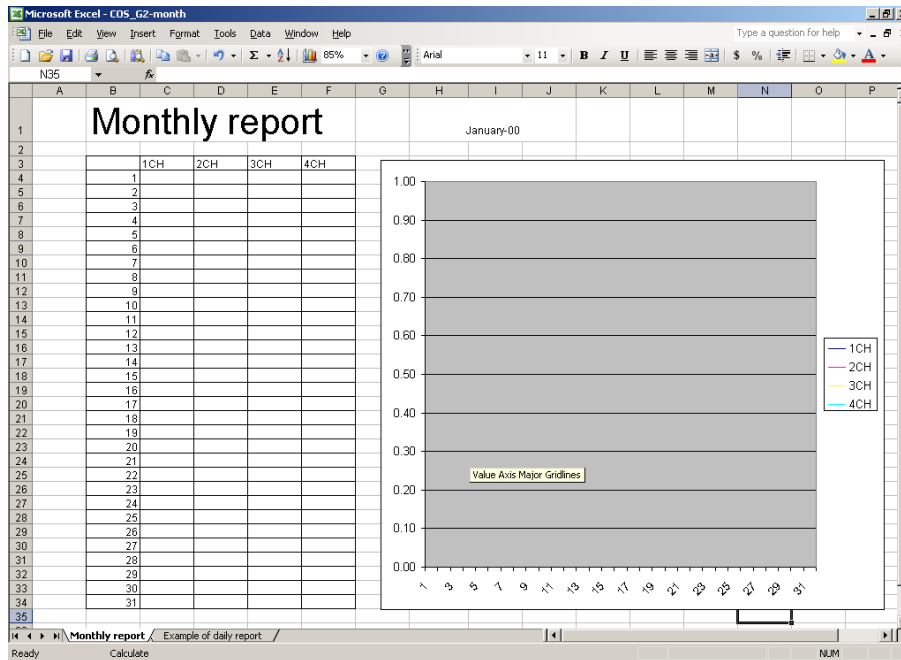

2. Open the input screen by double-clicking on the cell where the data is pasted.

Specify the position of the daily report data to be used. Since the daily report contents is displayed when the cursor is placed here, click on the desired cell.

Use here for inputting the created contents continuously in the time direction or the channel direction.

Select whether the calculation for average, maximum, etc. is applied to the data in the entire month or is applied to the data in the specified days. When the “Day specified” is selected, the function type is not selectable and the data in the specified position in the specified day are only used.

Select the function type for the data calculated.

When this is checked and the calculated result is an error, its result is displayed as a blank instead of an error indication.

3. By clicking the “OK” after setting all items, the formula is written in the cell.
4. After the creation is complete, execute the overwrite-save of the file and quit.



# CHINO

---

## CHINO CORPORATION

32-8,KUMANO-CHO,ITABASHI-KU,TOKYO 173-8632

Telephone:81-3-3956-2171

Facsimile:81-3-3956-0915

E-mail: [inter@chino.co.jp](mailto:inter@chino.co.jp)

---



Printed in Japan ( )