

KPSI 750 submersible level transducer



FEATURES

- NON-CLOGGING 2.75" TEFLON COATED ELASTOMERIC DIAPHRAGM
- INTEGRAL DIAPHRAGM PROTECTOR
- CUSTOM LEVEL RANGES FROM 10-115FT (3-35M) H₂O
- CUSTOM POLYURETHANE OR ETFE CABLE LENGTHS
- ±0.25% FSO STATIC ACCURACY
- MULTIPLE ANALOG OUTPUTS
- WELDED 316SS OR TITANIUM
- OPTIONAL LIFETIME LIGHTNING PROTECTION
- CUSTOM-BUILT IN TWO DAYS

- TWO YEAR WARRANTY
- SHIPPED WITH LONG LIFE VENT FILTER

APPLICATIONS

- LIFT STATIONS
- WASTEWATER
- SLURRY TANKS
- PUMP CONTROL

KPSI 750 specifications information

FULL SCALE LEVEL RANGES

Intermediate Level Ranges Available

Vented gage reference.....10 thru 115 ft (3 thru 35 m) H₂O
 Proof Pressure.....1.5 X FS
 Burst Pressure.....2.0 X FS

STATIC PERFORMANCE

Combined effects of Non-linearity, Hysteresis and Repeatability, Best Fit Straight Line method

Static Accuracy.....±0.25%FSO
 Resolution.....±0.0001%FS

ENVIRONMENTAL

Wetted Materials.....316 SS; Delrin®; Teflon® PTFE polyurethane or Viton®. Delrin® and Viton® are registered trademarks of DuPont.

Compensated Temp Range.....0 to 50°C
Maximum allowable deviation from the Best Fit Straight Line due to a change in temperature

Thermal Error.....±0.10%FSO/ °C worst case for level ranges >23' (7m) H₂O, prorated for level ranges ≤ 23' (7m) H₂O

Operating Temperature Range.....-20 to 60°C when attached to polyurethane cable

Protection Rating.....IP 68, NEMA 6P

ELECTRICAL

Excitation..... • 9-28V - VDC output (0-5V, 0-2.5V, 0-4V)
 • 9-28V - mA output (4-20) • 15-28V - VDC output (0-10V)
 • 10-28V - VDC output (1.5-7.5V)

Input Current.....20 mA max, for mA output; 3.5 mA max, for VDC output

Output..... 4-20 mA, 0-5 VDC, 0-2.5VDC, 0-4VDC, 0-10VDC, 1.5-7.5VDC

Zero Offset.....±0.25 mA for mA output, < 0.25 VDC for VDC output

Output Impedance.....See Loop Resistance diagram for mA output, 20 ohm for VDC output
 Insulation Resistance.....100 mega ohm at 50 VDC
 Circuit Protection.....Polarity, surge/shorted output

CERTIFICATIONS

UL, CUL and FM - Intrinsically safety approved
 CE compliant to EN 61326-1:2001 and EN 61326-2-3:2006

PHYSICAL

Approximate Weight.....3.5 lbs (1588 g) transducer, 0.05 lbs/ft (79 g/m) cable

Cable Jacket Material.....Polyurethane (standard), Tefzel®, Teflon® and Kevlar® are registered trademarks of DuPont.

ETFE (optional), ETFE is a fluoropolymer (Teflon® derivative) material, Tefzel® or equivalent

Cable Pull Strength.....200 lbs (90 kg)

Cable Number of Conductors.....4

Cable Conductor Size.....22 AWG

Cable Seal.....Molded Polyurethane for polyurethane cable, Viton® Gland for ETFE cable

TEMPERATURE OUTPUT OPTION (not intrinsically safety approved)

Temperature Range.....-20 to 60°C, available for 4-20mA output versions only

Output Signal.....4-20 mA

Temperature Measurement Accuracy.....±4°C

LIGHTNING PROTECTION (OPTIONAL)

Power supply needs to be limited to 150 mA to avoid lock up of the gas tube after a suppression event

Life Expectancy.....> 1,000 operations

Peak Clamping Voltage.....36 volts

Response Time.....<10 nsecs

KPSI 750 technical data

ELECTRICAL TERMINATION

| 22AWG CONDUCTORS IN A SHIELDED CABLE WITH VENT TUBE | | |
|---|-----------------------|--|
| 4-20 mA | RED BLACK | + EXCITATION - EXCITATION |
| 0-5 VDC | RED BLACK WHITE | + EXCITATION - EXCITATION + SIGNAL |
| ALL | DRAIN WIRE | SHIELD |

LOOP RESISTANCE VS. POWER SUPPLY

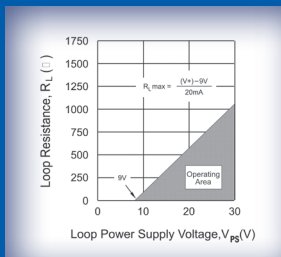

MOLDED CABLE SEAL CONFIGURATION FOR POLYURETHANE CABLE

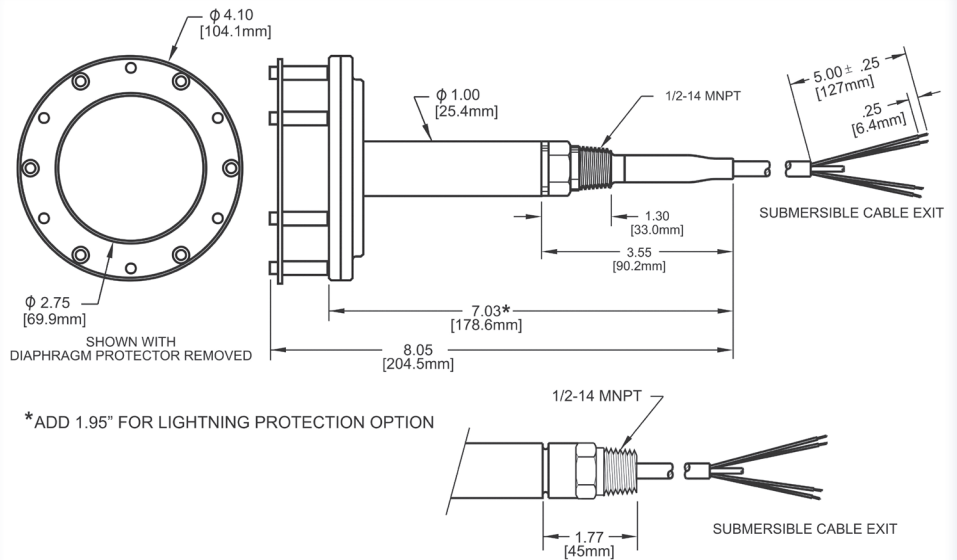

KPSI 750 order information



MODEL 750, $\pm 0.25\%$ ISO Static Accuracy
MATERIAL S, Stainless Steel
REFERENCE FORMAT 1, Vented gage
OUTPUT 3, 0-5 VDC, F, 0-2.5V, G, 0-4V, H, 0-10V, J, 1.5-7.5V
 4, 4-20 mA, 6, 4-20 mA temp. measurement option
PRESSURE CONNECTION D, Diaphragm protector
ELECTRICAL CONNECTION A, 1/2" - 14 NPT male conduit fitting with molded cable seal
 B, 1/2" - 14 NPT male conduit fitting with gland
LIGHTNING PROTECTION A, None, B, Full Lightning Protection
LEVEL RANGE (at MAX output) # # # . # # #
LEVEL RANGE (at MIN output) # # # . # # #
MOISTURE PROTECTION B, Vent Filter, C, Aneroid Bellows
CABLE TYPE 1, Polyurethane, 2, ETFE
CABLE LENGTH (in feet) # # # #
LABEL A, Psi, B, ft H₂O, C, m H₂O

EXAMPLE 750 S 1 F D 4 B 004 . 334 014 . 000 B 1 0055 A

1. The part number requires two level range limits, corresponding to maximum and minimum outputs, to be specified in **pounds per square inch (psi)** to three decimal places. The lower level range is typically 000.000 unless otherwise required. For reverse output requirements, enter the lower range for the maximum output and the upper range for the minimum output. Use the following conversion factors:

ft H₂O / 2.3073 = psi Examples: 10 ft H₂O / 2.3073 = 4.334 psi (enter 004.334 in the part number)
 m H₂O / 0.703265 = psi 10m H₂O / 0.703265 = 14.219 psi (enter 014.219 in the part number)

2. Contact PSI if private labeling is required.

Warranty: The Series 750 product is warranted against defects in material and workmanship for 2 years from date of shipment. Products not subjected to misuse will be repaired or replaced. THE FOREGOING IS IN LIEU OF ANY OTHER EXPRESSED OR IMPLIED WARRANTIES. We reserve the right to make changes to any product herein and assume no liability arising out of applications OR USE OF ANY PRODUCT OR CIRCUIT DESCRIBED. PRODUCTS DESCRIBED IN THIS SPECIFICATION ARE NOT INTENDED FOR LIFE SUPPORT APPLICATIONS.