

SHPFI-M

Smart Frequency to Current Loop Powered Flow Transmitter with Scaled Pulse Output

Features

- Accepts Inputs From: Magnetic Pickups, Contact Closures, DC Pulses (Optically Isolated) from Pulse Producing Flowmeters
- 4-20mA Analog Output Option (8 updates/sec)
- 20 Point Linearization
- Isolated Scaled Pulse Output of Total
- Nonvolatile Flash Memory of Setup Data and Calibration Information
- Setup Software for Easy Programming and Monitoring Using a PC and Special Serial Cable (BSAC1)

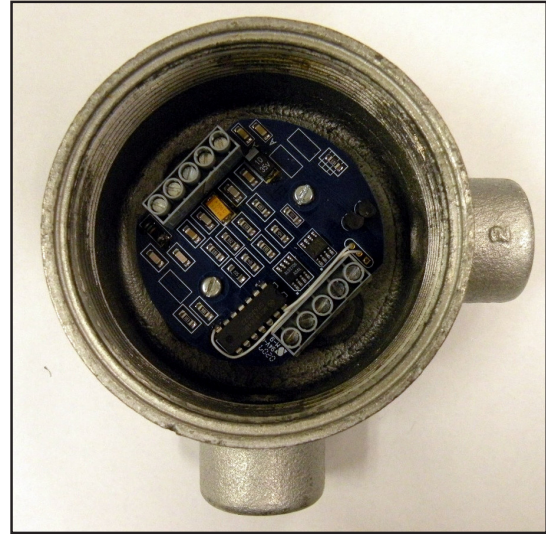

Description

The SHPFI-M is a smart frequency to current converter and also a frequency to frequency pulse scaler. It is intended to be used with flow meters and similar devices who generate a pulse signal either from a magnetic pickup or a contact closure whose frequency is related to flow rate and where each pulse represents a quantity of flow. The SHPFI-M also contains a linearization function commonly required by flow meters to improve their accuracy. The flow rate and total are computed within the SHPFI-M and the 4-20mA analog output and the high level scaled pulse output are generated from these computed values. The SHPFI-M is programmed using a special setup program from a PC. A special programming cable called the BSAC1 is also required. These items are purchased separately. The computed Rate and Total may also be viewed on your PC using these special cables.

Specifications

POWER:

LOOP POWERED

Voltage: 8.5 to 30 VDC
Protection: Reverse Polarity Protection on Current Loop
Loop Burden: 8.5V maximum

COMPUTATION:

Rate Computation
5 Digits (99999), updates 8X per second
Time base: /SEC, /MIN, /HR/DAY
Min. Input Frequency: 0.01 Hz to 10 Hz (selectable delay of 0.1 to 99.9 seconds) Selectable Rate Damping

PULSE OUTPUT OF COMPUTED TOTAL:

The pulse output advances with the least significant digit of the computed totalizer or decimal multiples thereof (see Pulse scale divider).
Type: Isolated photomos relay
Max. voltage (off state): 30 VDC
Current (on state): 100mA
Pulse Duration: Selectable 0.5, 0.25, 0.125, 0.0625 seconds
Pulse Scale divider (Pulscale): User selectable, +1, +10, +100 or OFF

ACCURACY:

0.01% Computed Rate, ± 1 least significant digit of computed rate
Temperature Drift: 50 ppm/ $^{\circ}$ C Worst Case

ENVIRONMENTAL:

OPERATING TEMPERATURE

-4 $^{\circ}$ F (-20 $^{\circ}$ C) to +158 $^{\circ}$ F (70 $^{\circ}$ C)
Extended Temp: -22 $^{\circ}$ F (-30 $^{\circ}$ C) to +158 $^{\circ}$ F (70 $^{\circ}$ C)

HUMIDITY

0 - 90% Noncondensing

MOUNTING STYLES:

- | | |
|----------------------|-------------------------------------------------------------------------------|
| 0- OEM- | OEM option |
| 2- Wall Mount - | NEMA 4X Enclosure |
| 3- Explosion Proof - | Class I, Division I, Groups B, C & D
Class II, Division I, Groups E, F & G |

NOTE: Meter mounting kits available (consult Factory)

INPUTS:

MAGNETIC PICKUP INPUT

Frequency Range: 0 to 3500 Hz
Trigger Sensitivity: 10 mV p-p (nominal)
Over Voltage Protected: ± 30 VDC

OPTO-ISOLATED DC PULSE INPUT

High (logic 1): 4-30 VDC
Low (logic 0): Less Than 1 VDC
Minimum Current: .5 mA
Hysteresis: 0.4 VDC
Frequency Range: 0 to 5 kHz
Min. Pulse Width: 0.1 msec

CONTACT CLOSURE INPUT (contact closure to common)

Internal Pullup Resistor: 100 K Ω to +3.6 VDC
High (logic 1): Open or 4-30 VDC
Low (logic 0): Less Than .5 VDC
Internal Switch Debounce Filter: 0 to 40 Hz (others on request)

K-FACTOR

Range: 0.001 to 99999999
Decimal Point Locations: XXXX.XXXX to XXXXXXXX

20 POINT LINEARIZATION

This feature allows the user to enter 20 different frequencies with 20 different corresponding K-Factors to linearize non linear signals.

ANALOG OUTPUT:

Type: 4-20 mA follows computed rate display, Two wire hookup
Accuracy: 0.025% Full Scale at 20 $^{\circ}$ C
Temperature Drift:
50 ppm/ $^{\circ}$ C Typical
Reverse Polarity Protected
Update Rate: 8 times/second

COMMUNICATIONS ACCESSORY:

RS232 SERIAL SETUP SOFTWARE

This accessory enables you to access a variety of process parameters through serial communications. PC compatible communications software is included with this cable. With this software and a Serial Adapter Cable (BSAC1) you will be able to setup the unit through your PC.

Dimensions:

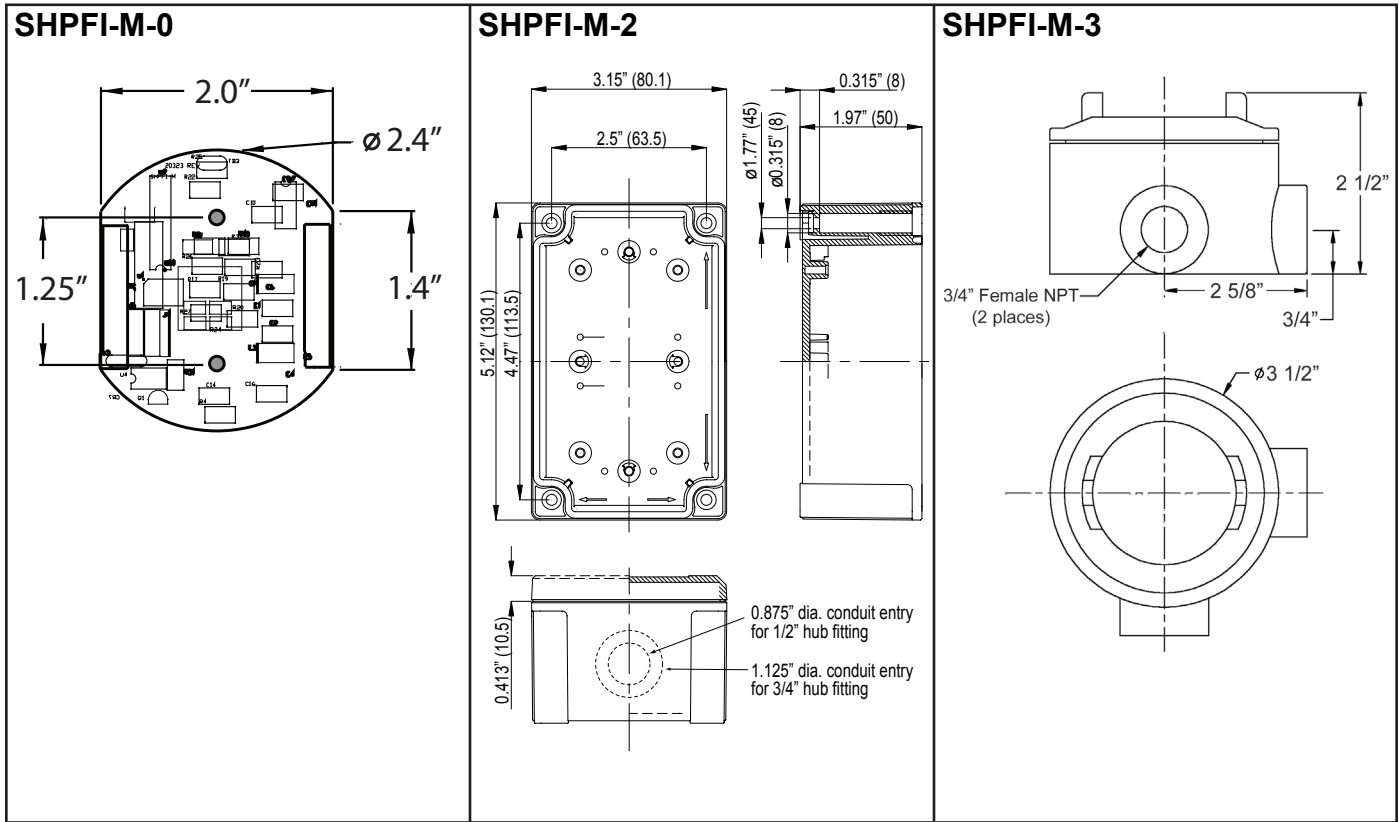

Typical Wiring:

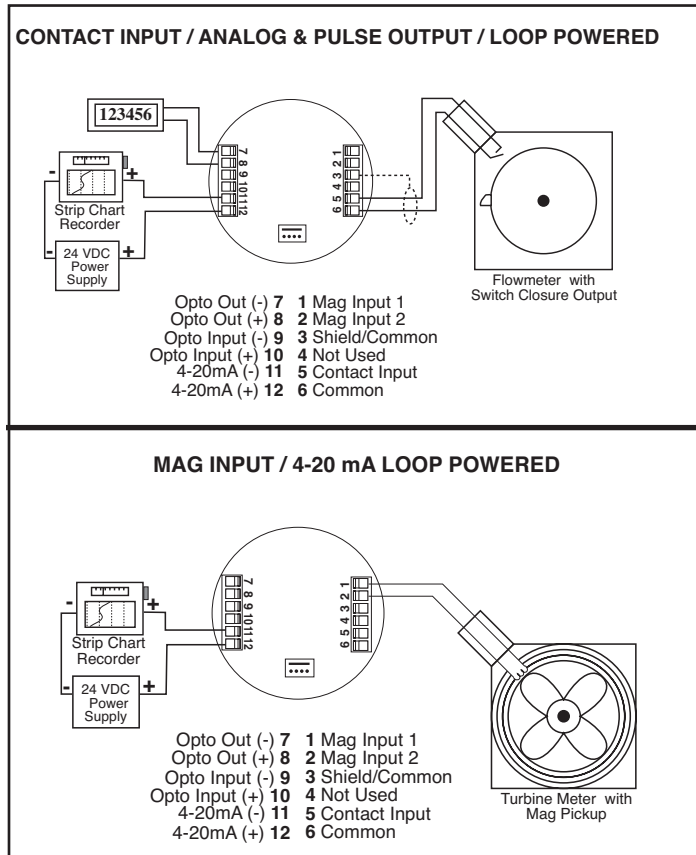

Decoding Part Number:

Ordering Information

EXAMPLE: SHPFI-M 2 HF2 ET

Series: _____
Mounting: _____
 0 = OEM
 2 = NEMA 4X Box
 3 = Explosion Proof Housing

Mounting Options for NEMA 4X: _____
 H2 = 0.875" Hole for NEMA4X mounting style
 HF2 = 0.5" Female NPT Hub fitting for NEMA4X mounting style
 H3 = 1.125" Hole for NEMA4X mounting style
 HF3 = 3/4" Female NPT Hub fitting for NEMA4X mounting style

Additional conduit entry configurations are available, consult factory.

Options (Multiple Options Available) _____
 ET = Extended Temp.: -22°F to 158°F (-30°C to 70°C)
 CE** = CE Compliant
 CSA** = CSA Listed Explosion Proof (planned)
 IS** = UL Listed IS (planned)

Accessories:
 115-24 = 115 VAC to 24 VDC power supply
 BSAC1 = RS232 Serial Adapter Cable (for programming only) with setup software. For use with S1 option.
 TFM-MK -1 = Turbine Flow meter Mounting Kit for flow meters with a 1" Male NPT riser
 TFM-MK -3/4 = Turbine Flow meter Mounting Kit for flow meters with a 3/4" Male NPT riser
 CA-TM-2-18-FL = 18" Turbine Flow meter Cable Assembly