

P295

Installation & Operating Instructions



Printer parts

- (1) Upper case
- (2) Printer cover
- (3) Operation panel
- (4) Document table
- (5) POWER switch
- (6) Interface connector
- (7) FG
- (8) Drawer kick-out connector
- (9) Power connector
- (10) DIP switches

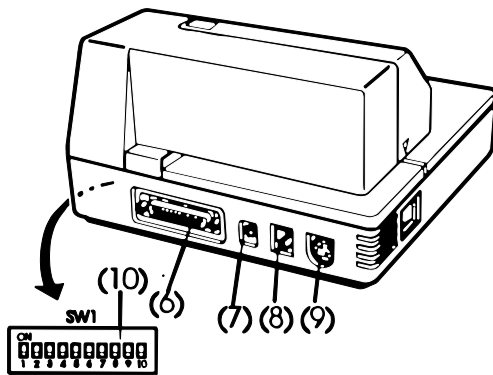
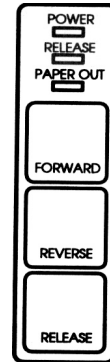
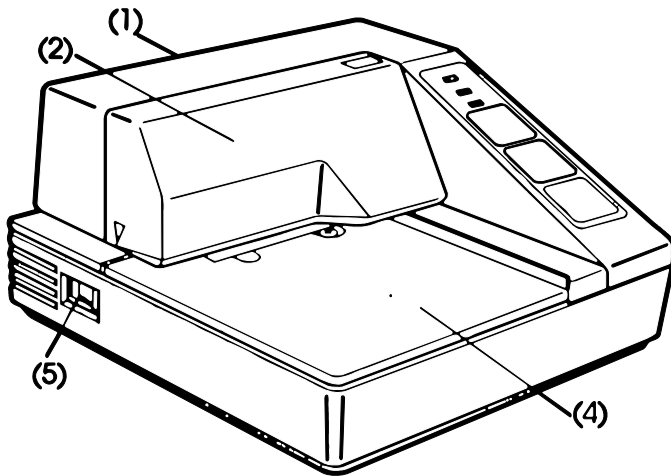

P295

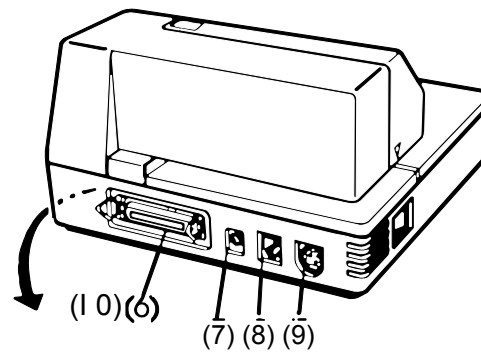

P295P

Chapter 1

Installation

Unpacking

The illustration below shows the items included for the standard specification printer.

If any item is damaged, please contact your dealer for assistance.

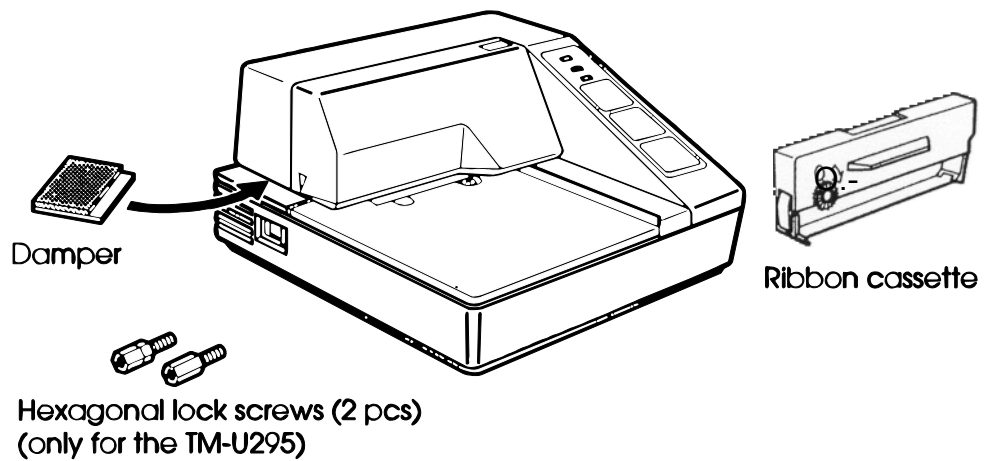

- Note:
See the Note on page 1-3 for information about the screws.

Removing the Transportation Damper

The printer is protected during shipping by a transportation damper that must be removed before you turn on the printer.

1. Pull the damper out and remove the strip of tape from the top of the printer, as shown below.

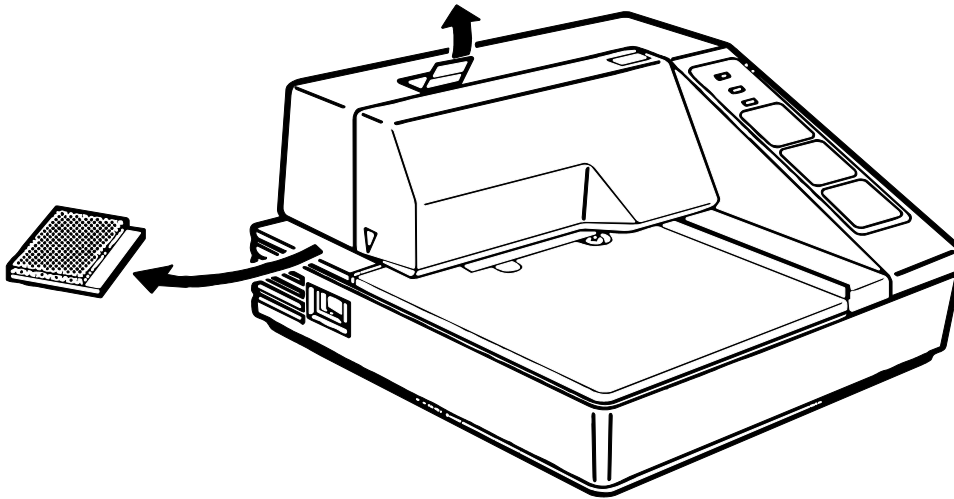

Note:

steps: turn on the printer, press the RELEASE button, press the FORWARD button, turn off the printer, and put the transportation damper back where it was when you received the printer.

Connecting the Printer to the Computer

You need an appropriate interface cable to connect your computer to the printer.

P295

You need an appropriate serial interface cable to connect your computer to the printer.

1. Make sure that the printer and the computer are turned off. Then plug the cable into the connector on the back of the printer, as shown.

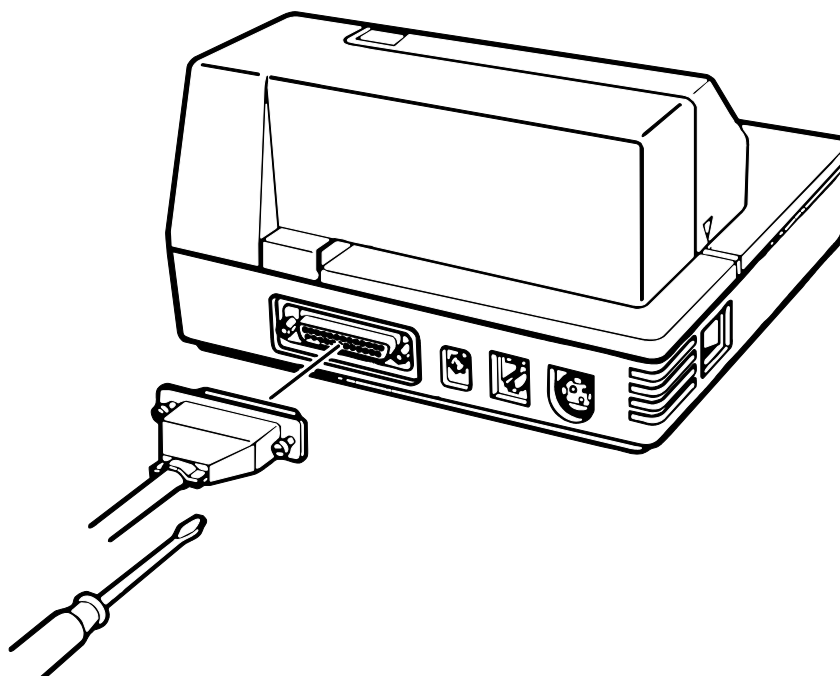

• Note:

Your printer comes with inch-type hexagonal lock screws installed. If you plan to use an interface cable that requires millimeter-type lock screws, replace the inch-type screws with the enclosed millimeter-type screws by using a hex screwdriver (5 mm). To distinguish the two types of screws, see the illustration below; the screw on the right is the millimeter type.

2. Connect the other end of the cable to the connector on your computer.

P295

You need an appropriate parallel interface cable to connect your computer to the printer.

1. Make sure that the printer and the computer are turned off. Then plug the cable into the connector on the back of the printer, as shown.

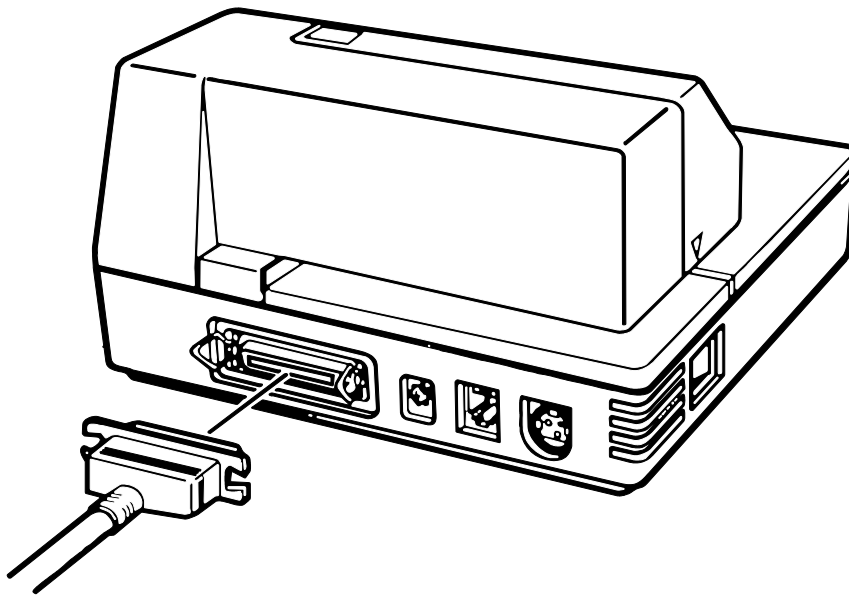

• Note:

Squeeze the wire clips on the printer together until they lock in place on both sides of the connector.

2. Connect the other end of the cable to the connector on your computer.

Connecting the Printer to the Drawer

Plug the drawer cable into the drawer kick-out connector on the back of the printer next to the computer interface connector.

P295

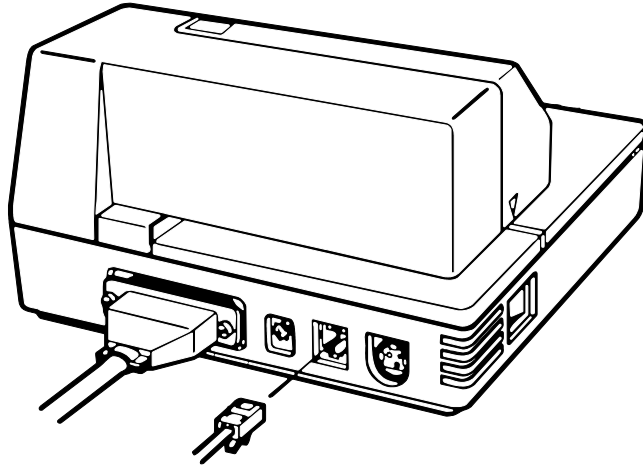

P295P

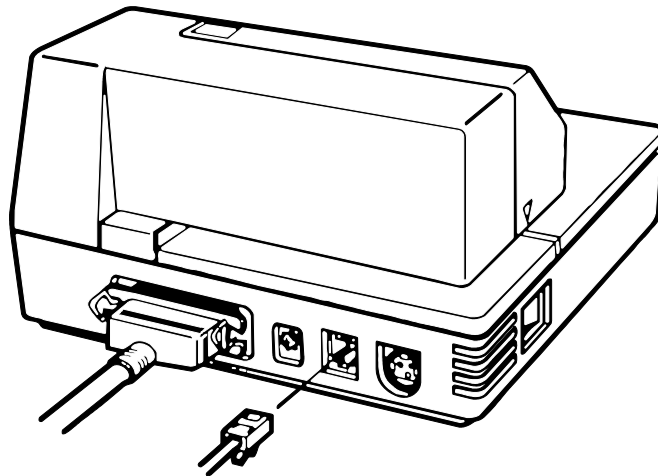

CAUTION:

Do not connect a telephone line to the drawer kick out connector.

Grounding the Printer

You need an appropriate ground wire to ground your printer. Recommended wire is described below.

Thickness of wire: AWG 18 or equivalent
Diameter of terminal to be attached: 3.2

1. Make sure that the printer is turned off.
2. Connect the ground wire to the printer using the FG screw on the back of the printer, as shown.

P295

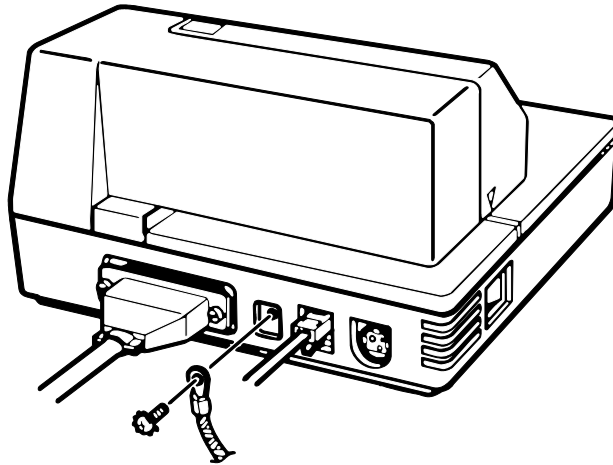

P295P

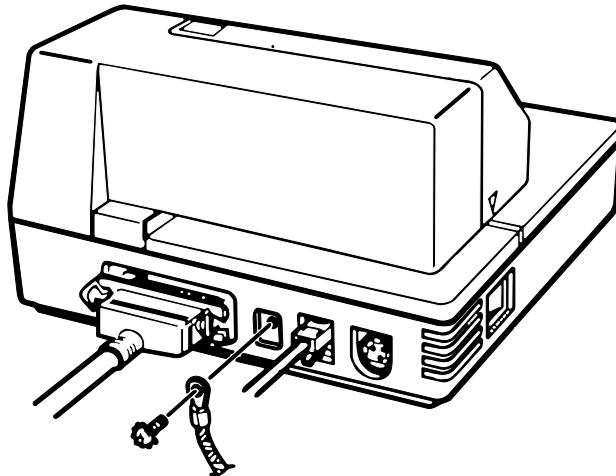

Connecting the Power Supply

This printer requires an external power supply. The EPSON Power Supply PS-150 is recommended.

CAUTION:

Using an incorrect power supply can cause serious damage to the printer.

1. Make sure that the power supply is turned off.
2. Plug the power supply's cable into the printer's connector as shown below. Note that the flat side of the connector faces up.

P295

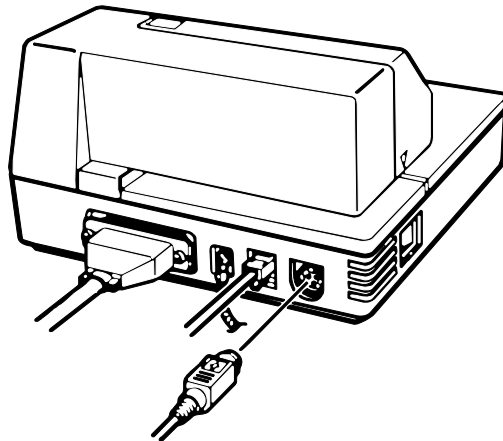

P295P

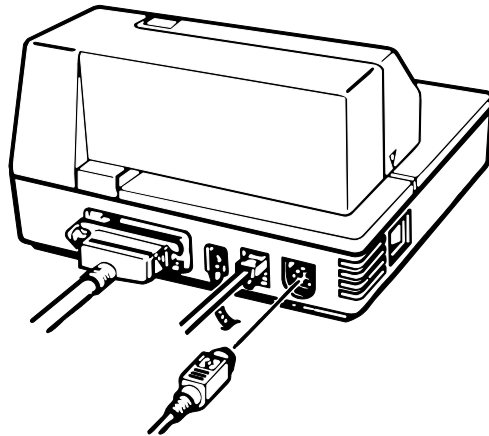

3. Plug the power cord into an outlet.

Installing the Ribbon

Be sure to use a ribbon cassette that meets the printer's specifications. The EPSON ERC-27 is recommended.

• *Note:*

For instructions on replacing a used ribbon, see Chapter 2.

1. Turn the printer on using the power switch on its left side.
2. Press the RELEASE button to turn the light on. This puts the printer in the paper release mode.
3. Turn the printer off.

⚠ CAUTION:

Be sure to perform the steps above because it is necessary to make sure that the printer is in the paper release mode before you install the ribbon cassette.

4. Open the printer cover by slightly pressing the ridges on the top left and pulling the cover forward, as shown in the illustration below.

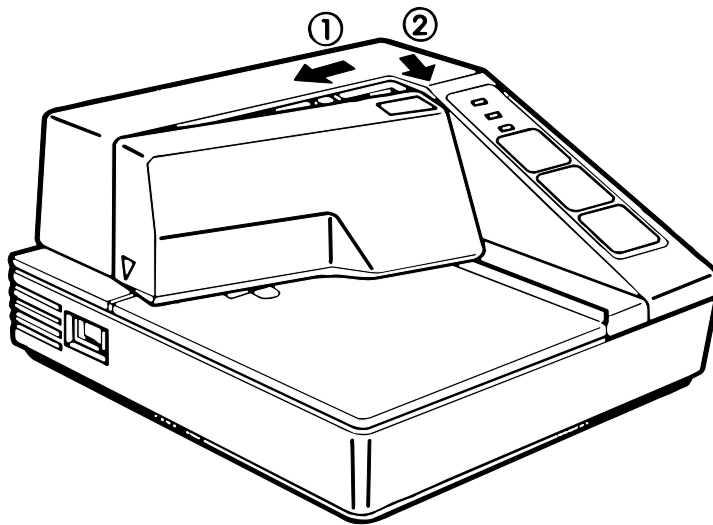

5. Check to see that the ribbon in the cassette is not creased or twisted, Then turn the feed knob in the direction of the arrow on the ribbon cassette to take up any slack in the ribbon.

6. Carefully insert the ribbon cassette in the printer as shown in the illustration below. Notice exactly where the ribbon must go.

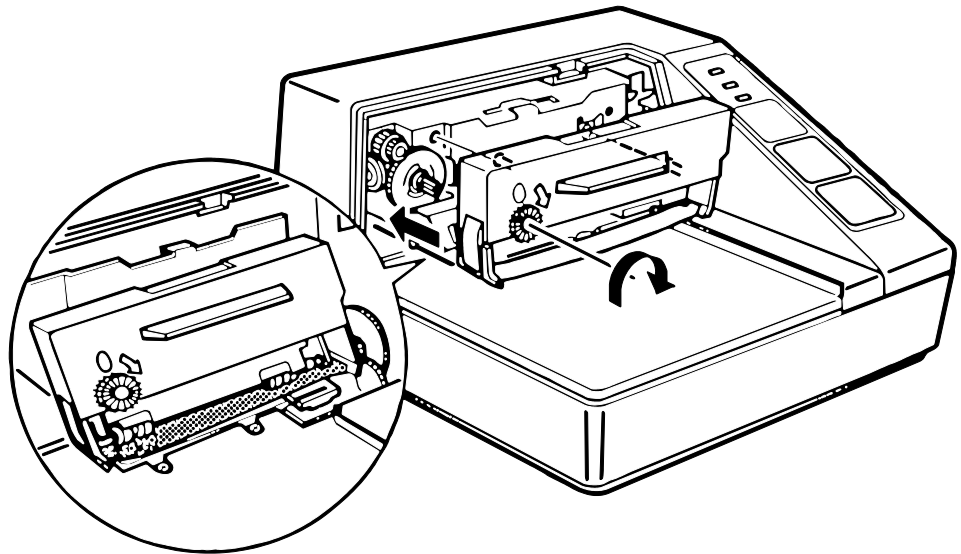

7. Then push firmly on the right side and then the left side of the ribbon cartridge until each side clicks into place.

4. Insert the paper from either the front or the side, as shown in the illustration below. Insert the paper into the printer until it is stopped by the form stopper. The markings on the side of the printer can also be used to judge how far to insert paper.

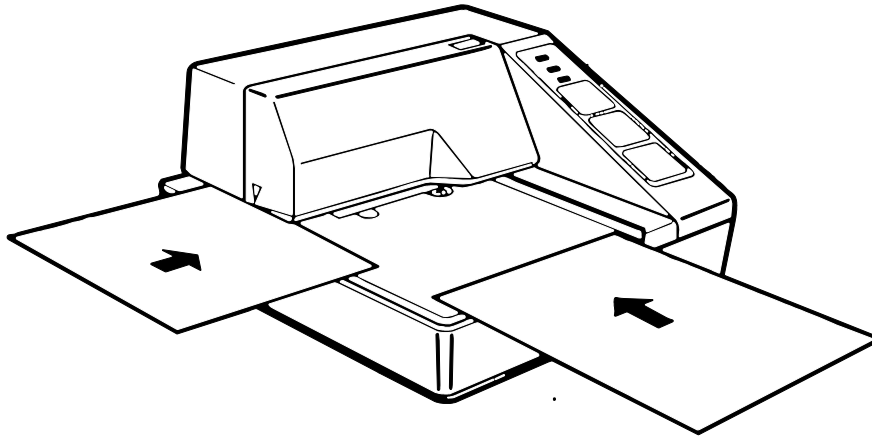

5. Check the PAPER OUT light. When you insert the paper correctly, the PAPER OUT light goes out. If the PAPER OUT light is still on, remove the paper and re-insert it.

Running the Self Test

Any time that you want to check the performance of your printer you can run the self-test described below. This shows whether your printer is working correctly. It is independent of any other equipment or software.

The self test checks the control circuits, printer mechanisms, print quality, RAM, ROM version', and DIP switch settings.

To Perform the self test, follow the steps below:

1. Insert a sheet of paper following the instructions on page 1-12.
2. Turn off the printer.

3. While holding down the RELEASE button, turn the printer back on.
4. Remove your finger from the RELEASE button. The printer prints the current printer settings and then eject the paper.
5. Press the RELEASE button to eject the paper completely and insert new paper to begin the second part of the test.

After the printer prints a pattern, it prints the following message:

completed

The printer ejects the paper; then enters the normal mode.

Setting the DIP Switches

You can change several interface settings by changing the DIP switch settings. If you need to change any of these settings, follow the steps below:

1. Make sure that the printer is off.

2. Turn the printer over and locate the DIP switches, as shown below.

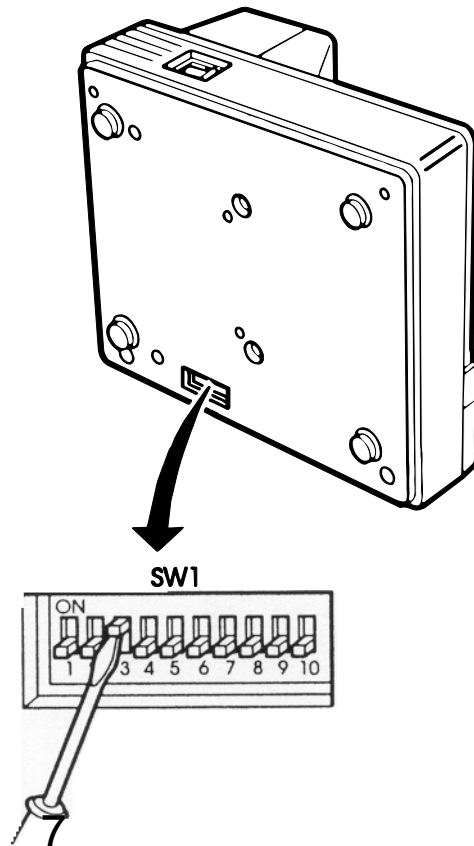

3. Notice that ON is marked on the set of switches. Use tweezers or another narrow tool to move the switches.
4. Use the following tables to set the DIP switches.

P295

Switch	Function	ON	OFF
	Data reception error	Ignored	Prints'?'
2	Receive buffer capacity	35 bytes	512 bytes
3	Handshaking	XON/XOFF	DTR/DSR
4	Word length	7 bits	8 bits
5	Parity check	Yes	No
6	Parity selection	Even	Odd
7			
8	See Transmission Speeds table below,		
9	Pin 6 reset signal	Used	Not used
10	Pin 25 reset signal	Used	Not used

Transmission Speeds

Speed in Bits per Second	SW 7	SW 8
1200	ON	ON
2400	OFF	ON
4800	ON	OFF
9600	OFF	OFF

Chapter 2

Using the Printer

The control panel has three buttons and three lights.

Buttons

All three of these buttons can be disabled or enabled by the **ESC 5** command.

RELEASE

Pressing this button moves the rollers so that paper can be inserted or removed.

REVERSE

Feeds the paper backward based on the line feed amount set by **ESC 2** and **ESC 3**.

FORWARD

Feeds the paper forward based on the line feed amount set by **ESC 2** and **ESC 3**.

You can also use the RELEASE button to start a self-test. See Chapter 1 for details.

Indicator Lights

POWER

This light is on whenever power is supplied to the printer.

RELEASE

This light is on when the printer is in the paper release mode and it is off when the printer is in the clamp mode. Paper can be inserted only when the printer is in the paper release mode.

This light blinks to indicate an error condition in the following cases:

- Paper jam
- Home position error
- Timing error
- Drive circuit error
- Power supply voltage error

If this light blinks, turn off the printer, make sure that no paper is jammed in it, and then turn it back on. If the light is still blinking, contact a qualified service person.

PAPER OUT

This light is on when paper is not inserted or is not inserted correctly.

Replacing a Used Ribbon

When your printing is not dark enough, it is time to replace the ribbon.

First follow steps 1 through 4 in the "Installing the Ribbon" in Chapter 1.

Then remove the used ribbon by grasping the handle and pulling straight out, as shown by the arrow in the illustration below.

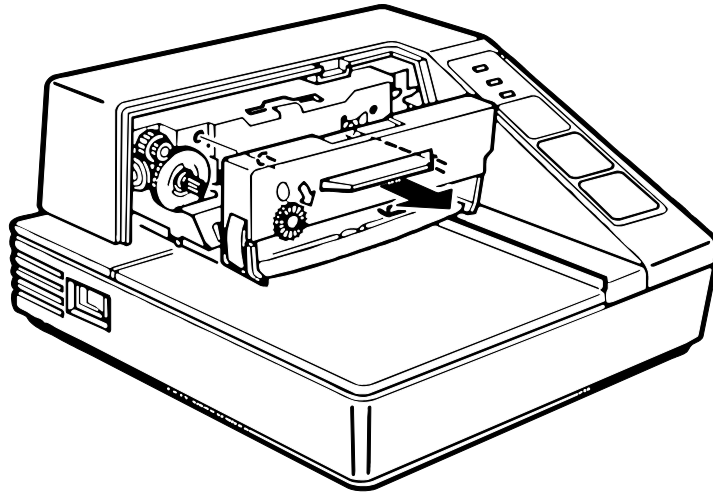

Then follow the rest of the steps in "Installing the Ribbon" in Chapter 1.

Chapter 3

Troubleshooting

This chapter gives the solutions to some printer problems.

Power Problems

The **POWER** light does **not** come on.

Make sure that the power supply cables are correctly plugged into the printer, the power unit, and to the power outlet.

Make sure that power is supplied to the power outlet. If the outlet is controlled by a switch or timer, use another outlet.

Printing problems

The **PAPER OUT** light is on and nothing is printed.

If the PAPER OUT light is on, the paper is not inserted or is not inserted correctly.

The **RELEASE** light is flashing and nothing is printed.

This indicates an error condition. Turn off the printer, make sure that no paper is jammed in it, and then turn it back on. If the RELEASE light is still flashing, contact a qualified service person.

Chapter 4

Reference Information

Printing Specifications

Printing Method:	Impact dot matrix
Head Wires	7-pin shuttle type
Printing Direction:	Unidirectional
Lines per second	5 x 7 font: 1.9 to 2.3 7 x 7 font: 1.9 to 2.3
Characters per line	5 x 7 font: 35 7 x 7 font: 42
Characters per inch:	5 x 7 font: ANK: 0.63 Graphics: 0.315 7 x 7 font: ANK: 0.63 Graphics: 0.315
Paper feed speed:	Approximately 12.5 lines (52.5 mm 12.10"/second) (When the ESC d and FF commands are used.)

Character Specifications

Number of characters	Alphanumeric characters: 95 Extended graphics: 128 x 3 International characters: 32
Character structure:	5 x 7 with 1-dot spacing (normal dot) 7 x 7 with 3-dot spacing (half dot)

Character size:

5 x 7 font:

ANK: 1.6 mm (.063") x 2.9 mm (.114")

Graphics: 1.9 mm (.075") x 2.9 mm
(.114")

7 x 7 font:

ANK: 1.3 mm (.051") x 2.9 mm (.114")

Graphics: 1.6 mm (.063") x 2.9 mm -
(.114")

Paper Specifications

Papertype:	Normal (high quality), pressure sensitive, and carbon copy papers	
Total thickness:	Single Ply Paper: 0.09 to 25mm (.0035" to .0098") Copy Paper: 0.09 to 0.35mm (.0035" to .0138")	
Paper size:	80 mm (W) x 69 mm (L) to 182 mm (W) x 257 mm (L) 13-15'-x 2.72," to 7.17" x 10.12") Up to the European B5 size.	
Copy capability and paper thickness:	No copies (single-ply)-.	0.09 to 0.25 mm 1.0035" to .0098.ff) (135 kg paper or equivalent)
	Combination of normal paper and pressure sensitive paper:	3 sheets maximum (1 original and 2 copies) (0.09 to 0.35 mm 1.0035" to .0138"))
		Backing paper: 0.07 to 0.20 mm 1.0028" to.0079"l Copy and original paper: 0.04 to 0.07 mm (.0016" to.0028") Carbon copy paper: Approximately 0.035 mm 1.0014"l

Copy capability and ambient temperature for printing:

Copying capability is influenced by the ambient temperature. Printing must be performed under the conditions, described in a Table below:

Relationship between ambient temperature and number of copies

Number of copies	Ambient temperature (print mode)
Original + 1 to 2 copies	5° to 40°C (41 11 to 104°F)

Notes on slip paper

- Slip paper should be flat, without curls, wrinkles, or camber, especially at the paper edges. Otherwise, the paper may become ink stained.
- When using multiply-ply carbon copy paper, it should be flat and the glue area should be as small as possible.
- Glue area should be located at the top or left edge of the slip paper.
- Since TOF and BOF sensors are optical sensors, paper having holes at the sensor positions or translucent paper should not be used normally. When using these papers, be sure to disable the paper sensors by **ESC c 4**.
- When using slip paper of 80 mm (3.15") long or less, load the paper so that it is fed straight.
- Use thinner paper (N30 or equivalent) between the top and bottom sheets of multi-ply paper. If thick paper is used, the copy capability is lowered.

Printing position

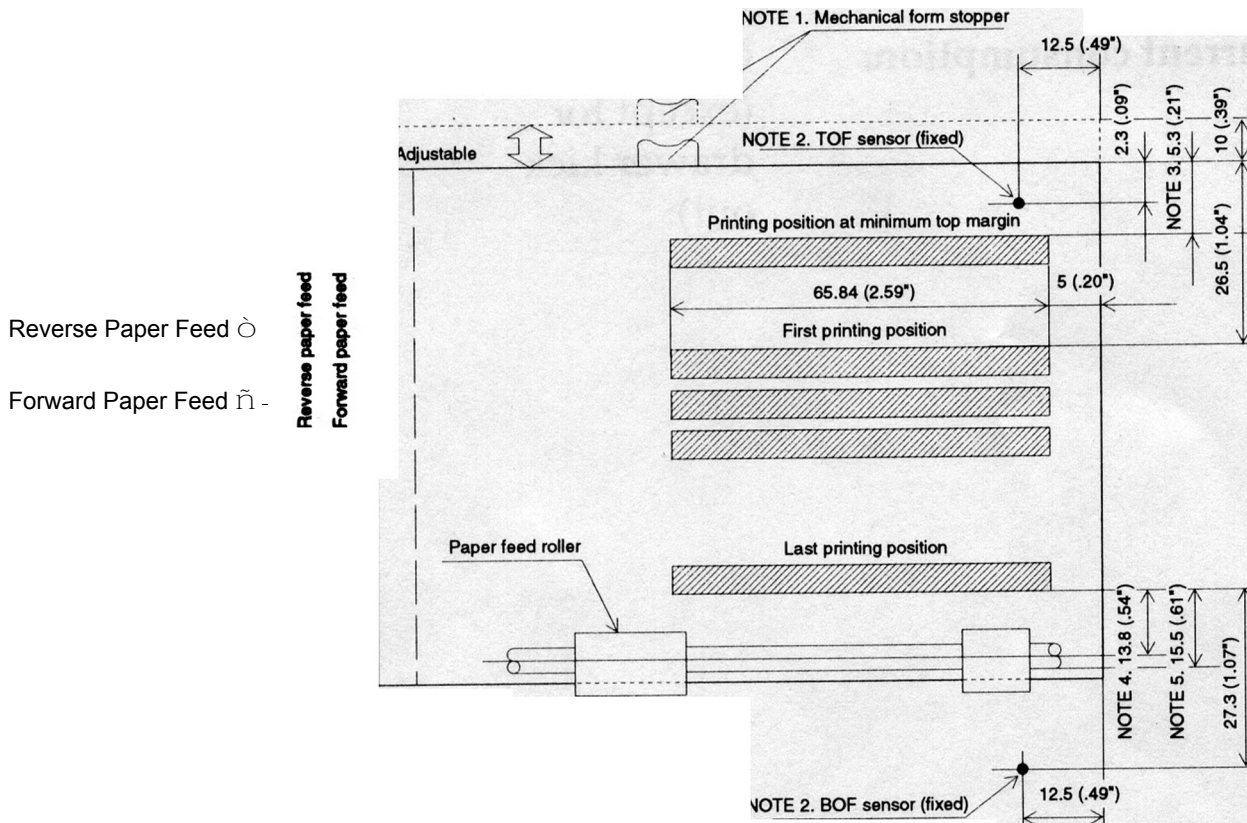

Notes

1. The mechanical form stopper is adjustable in the range 26.5 to 36.5 mm (1.04" to 1.44")
2. The TOF and BOF sensors are fixed and cannot be adjusted.
3. After slip paper is set at the mechanical form stopper, the top margin can be shortened up to 21.2 mm (.83") by feeding the paper backwards (ejection feeding).
4. When ejection feeding is not performed after printing, printing can be performed up to the position at which the paper edge is no longer held by the paper feed roller (13.8 mm) (.54") from the paper edge).
5. When ejection feeding is performed after printing, the paper can be fed forward up to 11.8 mm (.46") (28 dots) after the bottom edge is detected.

Electrical Specifications

Supply voltage: +24 VDC \pm 10%

Current consumption:	Operating (except for drawer kick-out):	Mean - approx. 600 mA at 24 VDC (full-column printing and data transmission of ANK characters)
		Peak - approx. 5.5 A at 24 VDC (full-column printing and data transmission of ANK characters)
		Standby: approx. 100 mA (at 24 VDC, 25°C (77°F))

4-6 Reference Information

Reliability

Life:	Mechanism:	3,000,000 lines
	Print head:	100 million characters (when in the average of 2 dots/wire per character.)
		<ul style="list-style-type: none">• End of Life is defined as the point at which the printer reaches the beginning of the Wearout Period.
MTBF:		180,000 hours
		<ul style="list-style-type: none">• Failure is defined as Random Failure occurring at the time of the Random Failure Period.
MCBF:		7,000,000 lines
		<ul style="list-style-type: none">• This is an average failure interval based on failures relating to wearout and random failures up to the life of 3 million lines.

Reference Information 4-7

Environmental Conditions

Temperature:	Operating:	5° to 40°C (41° to 104°F)
	Storage:	-10° to 50°C (14° to 122°F) (except for ribbon and paper)
Humidity:	Operating:	30 to 85% (with no condensation)
	Storage:	30 to 90% (with no condensation, except for ribbon and paper)

Interface Specifications

Serial interface:	RS-232 compatible
Parallel interface:	IEEE 1284 compatible (Nibble/Byte Modes)

- *Note:*
The interface is factory installed option. One of the interfaces (serial or parallel) is already installed.
- *Note:*
Refer to the EPSON TM-LI295IL1295P Specifications for details.