

**MODELS:**  
MRT-PW

# MINItrOI-PW SERIES

INSTALLATION & OPERATING INSTRUCTIONS

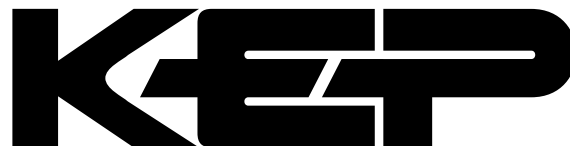

KESSLER-ELLIS PRODUCTS

10 Industrial Way East

Eatontown, NJ 07724

800-631-2165 • 732-935-1320

Fax 732-935-9344



<http://www.kep.com>

# TABLE OF CONTENTS

SPECIFICATIONS .....	1
DECODING PART NUMBER.....	2
HOW TO MOUNT THE UNIT .....	3
WIRING GUIDE LINES .....	4
WHAT CAN YOU VIEW .....	6
OUTPUT JUMPER SELECTIONS .....	6
MILLIVOLT INPUT OPTION JUMPER SELECTIONS.....	6
OPERATING FRONT PANEL .....	7
PROGRAMMING FLOW CHART .....	7
PROGRAM CODES & DESCRIPTIONS .....	8
WIRING TERMINATIONS.....	9
CALCULATING SCALE FACTOR .....	10
SETUP PROGRAMMING PROCEDURE .....	11
SETTING SCALING FACTOR .....	11
SETTING THE COUNTER.....	12
SETTING THE RATE .....	13
SETTING THE LOCK CODE & LOCKING THE UNIT .....	14
SETTING THE RELAYS & PRESETS .....	15
OUTPUT WIRING .....	16
ANALOG OUTPUT OPTION.....	17
RS232/RS422 SERIAL COMMUNICATIONS .....	18
TROUBLESHOOTING GUIDE.....	21
WARRANTY	

# DESCRIPTION & SPECIFICATIONS

## DESCRIPTION:

The Minitrol-PW is a single input counter/ratemeter intended for use with low flow paddle or pelton wheel turbine flowmeters. Two scale factors are used to describe the flowmeter calibration characteristics. The two 5 AMP preset relay outputs can be programmed by the user to apply to the "A" total counter or the "A" ratemeter. The user can view the rate, total and grand total.

## SPECIFICATIONS:

### DISPLAY

6 digit, 0.55" High LED

### INPUT POWER:

110 VAC  $\pm$  15% or 12 to 15 VDC

220 VAC  $\pm$  15% or 12 to 15 VDC

24 VAC  $\pm$  15% or 12 to 15 VDC

### CURRENT:

250 mA DC max. or 6.5 VA AC

### OUTPUT POWER (AC powered units only)

+12 VDC @ 50 mA, unregulated -10 + 50%

### TEMPERATURE:

Operating:

+32°F (0°C) to +130 F (+54°C)

Storage:

-40 F (-40°C) to +200°F (93°C)

### MEMORY

EEPROM stores data for 10 years if power is lost.

### INPUTS:

3: High Impedance DC pulse input 4-30 VDC (high), Open or 0-1 VDC (low), 10 K $\Omega$  imp. 10 kHz max. speed.

3M: Mag. Input, Rate/total input only, accepts 30mV input (50 V max. P/P) signals 10 K $\Omega$  imp. 5 kHz max. (Inhibit input, 4-30V)

**NOTE:** The Mag. input has filtering as follows: up to 300Hz @30mV, 5KHz @ .25V to 50V max.

### INHIBIT TOTAL INPUT

Terminal 6: 4-30 VDC level will inhibit totalization

### RESET:

Front Panel: Resets displayed value and control output

Remote: 4-30 VDC, negative edge resets Totalizer (Total A) and control output

**NOTE:** The remote reset will not reset Grand Total (Total B)

## K FACTOR/SCALING

The K-Factor is used to convert the input pulses to engineering units. The two 5 digit scale factors, with decimal keyed into any position, allow easy direct entry of any scaling factor from 0.0001 to 99999. Factor A is used to enter the linearized K-Factor and Factor B is used to enter the offset frequency.

## LOW FLOW CUTOFF:

A low flow cutoff is provided to inhibit operation in low flow out of range regions.

## CONTROL OUTPUTS:

Relays:

The relays may be assigned to rate or total.

2 each N.O. Relay; 5 Amps 120/240 VAC or 28 VDC. (N.C. relay contacts and NPN transistor output available with solder jumpers. Transistor output is internally pulled up to 10 VDC through relay coil, sinks from 10 VDC to .5 V @ 100 mA)

Analog Output:

An optional 4-20mA (0-20mA) output is available for the Minitrol series. The output can be programmed to track rate or total. This feature is available by adding suffix A to the part number. Connections are via a 2 terminal pluggable screw connector. Programming is accomplished by using the front panel in conjunction with rear dip switches.

Accuracy:  $\pm$  0.25% FS worst case.

Compliance Voltage: 3 to 30 VDC non inductive.

## RS232/RS422 SERIAL INTERFACE

If the serial interface option is supplied, up to 99 units can be linked together. (The terminal addressing the unit must be capable of driving all loads in the loop.) Unit status and new set points can be communicated by serial communication. Mode changes, however, must always be made on the front panel. Data is transmitted at selected baud rates using standard seven bit ASCII characters and parity with two additional bits of "Start" and "Stop" to make up the standard ten bit character.

Data is received and transmitted over standard EIA RS232 or RS422 levels. Each 10 bit character is made up of a start bit, 7 bit ASCII code, parity bit and stop bit. Unit number, baud rate and parity are entered in the "Program Setting" set up mode and remain in memory even if power is off.

Note that the input impedance of RS232 is 3K or 7K Ohm worst case. The terminal addressing the unit must be capable of driving all loads in the loop. RS422 input impedance is much higher and there is usually no problem driving 25 units. Unit serial transmit line remains in a high impedance "OFF" state until addressed.

# SPECIFICATIONS

(continued)

# DECODING PART NUMBER

## PRESETS

Two control outputs are provided. To set relay values, press "menu" button until "Relay" appears on the display, the A and B outputs can be assigned to the rate alarm (high/low), or for total (A) or grand total (B). A 5 digit value can be entered for both presets and the decimal point location is the same as the counter. The outputs can be set to energize from 0.1 to 99.9 seconds or latch (0.0). If a value other than 0.0 is entered, the totalizers will auto reset at the preset. This may be used to create a relay pulse output instead of grand total.

## LOCKOUT

Unauthorized front panel changes can be prevented by entering a user selected 5 digit code, in the "LOC" mode. The front panel can be completely locked out or the presets can remain accessible.

## RATEMETER

Accurate to 4 1/2 digits (±1 display digit). The rate meter can be programmed to accept almost any number of pulses per unit of measurement and auto-range up to 5 digits of significant information. The display can be programmed to read in units per Second (SEC), Minute (MIN), Hour (HOUR), or Day (DAY).

## COUNTER

The two 6-digit totalizers can count at 10kHz speed. They share a 5-digit dividing scale factor. The totalizer performs as follows:

### If Freq. In > Cutoff

$$\text{Total increment} = \frac{\text{Freq. Offset} \cdot \Delta \text{Time}}{\text{K Factor A}} + \frac{\text{Pulses In}}{\text{K Factor A}}$$

$$\text{Rate} = \frac{\text{Freqin} + \text{Freq offset} \cdot \text{time base}}{\text{K Factor A}}$$

Time base: Sec =1, Min = 60, Hour = 3600, Day = 86400

### If Freq. In < Cutoff

Total Increment = 0

Rate = 0

Total B (grand total) increments with Total A.

## THEORY OF OPERATION

Low flow, Pelton Wheel turbine flowmeters have a transfer characteristic which can best be represented by the following equation for frequencies above the minimum usable flowrate for the device:

$$\text{frequency} = \frac{K_{\text{linearized}} \cdot \text{GPM}}{60} - \text{Offset Frequency}$$

Where:  $K_{\text{linearized}}$  and offset frequency are scaling constants determined during flow sensor calibration.

This transfer characteristic applies with the meter manufacturers published range. Below some minimum flow meter output frequency, the flow rate should be considered as 0 and the totalization inhibited. This is called the "cutoff" frequency.

## MINItrol-PW (MRTPW)

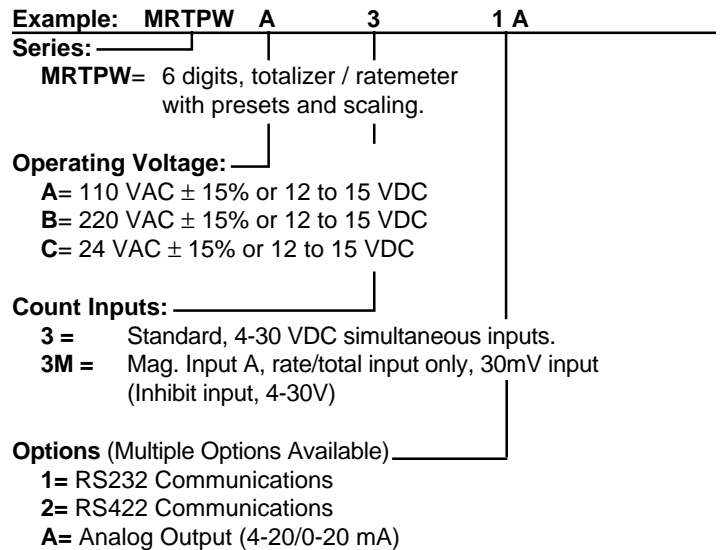

# HOW TO MOUNT THE UNIT

The unit is designed to be mounted with a gasket providing a water tight seal. Two mounting brackets are provided to secure the unit to the panel. A panel less than .1" may distort if the clamps are screwed too tightly.

Slide the body of the unit through the rubber gasket. Insert the unit into the panel. As shown in "FIG. A", slide the brackets up the groove to press against the back of the panel. Insert screws into rear of brackets and tighten them evenly and alternately. Do not over tighten! A normal level of torque is required. Maximum torque should be 3" pounds.

This product is designed to be panel mounted and is NEMA 4 rated if proper mounting procedures are followed and the required and supplied hardware is correctly used.

If the panel in which the unit is mounted is less than 0.125" thick, the possibility exists that there will be some flexing. Should this flexing occur, the resulting deformation of the panel could cause a loss of the water tight seal. In case this should occur, the use of silicone or other sealant would be recommended.

This product is designed to the NEMA 4 rated. However, the fact that we are unable to control either the location in which the device is installed or the actual installation itself requires that the company's liability shall extend only to the repair or replacement of a defective product.

We are prepared to offer additional assistance in those special situations where normal mounting methods do not seem to satisfy the customers needs. This assistance may be obtained by calling the factory and asking for Application Engineering.

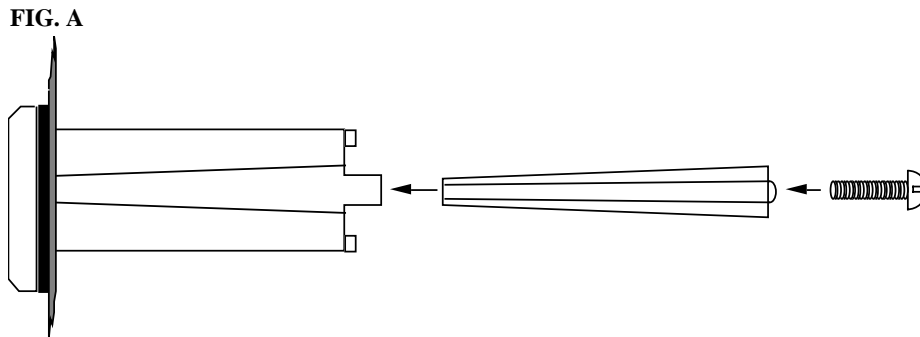

## DIMENSIONS

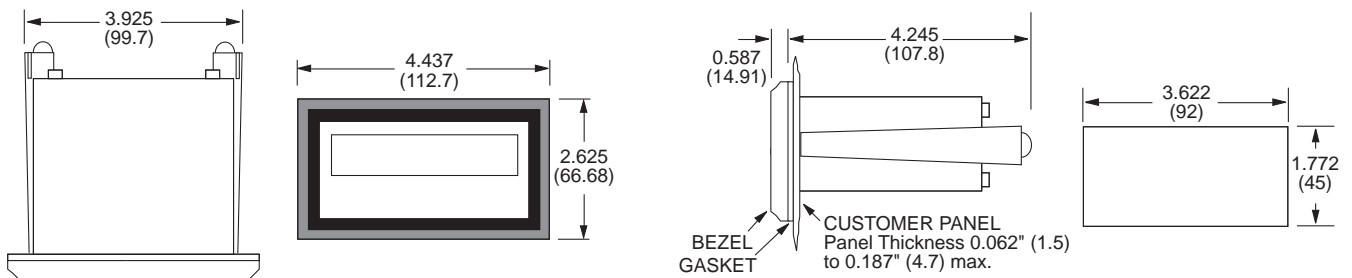

## WIRING GUIDELINES

The rear terminal contains 12 screw terminals for connecting #14 to #28 gauge wire.

The unit is controlled by a microprocessor and, therefore, an electrically "noisy" environment could cause operating problems. The input power line should not be common to power lines for motors, pumps, contactors, etc.

The unit is designed to be immune from line or transient voltage interference. In some environments voltage spikes of over 1000 volts can occur. When common to a power line driving motors voltage fluctuations can be extreme and rapid. Lines driving DC or AC solenoids, relays, or actuators can also cause problems.

Four sources of noise can occur:

- 1) AC power line noise - If the unit cannot be connected to a clean power source, an inductive load suppressing device (MOV as GE # V130LA1 or Resistor Capacitor as Paktron # .2 uf/220 ohm @ 400V) can be installed. Although locating the suppressor across the AC supply at the unit should help, best results are obtained by connecting the suppressor across the leads of the "load" at the device causing the spike.
- 2) Input line noise -The noise is carried on the input and D.C. ground lines. Make sure the input wires are never run into the unit in a bundle with power input lines. Also, keep these input lines isolated from inductive lines from devices drawing heavy loads. If there is a possibility of electrical noise, we recommend using shielded cable, with the shield being hooked to the D.C. ground terminal on the instrument, and to "earth" at one point in the circuit, preferably at the D.C. ground terminal of the unit.
- 3) Output lines - The unit has two relay outputs. When these outputs are used to run external relays or solenoids, spikes can be generated upon activation. This noise can spread through the instrument causing operating problems. If the source is a D.C. operated device, a general purpose diode (IN4004) placed across the solenoid prevents electrical noise spikes. Connect the cathode (banded side) to the more positive side of the coil. If the source is an A.C. operated device, use a MOV or Resistor Capacitor across the coil.
- 4) 12 VDC output supply - Noise can be generated on the 12 VDC output supply if it is used to drive inductive loads or if the current draw exceeds 50 mA. Insure that all inductive loads have a diode (such as IN4004) across the coil and that the current does not exceed 50 mA.

## TOTALIZER INHIBIT INPUT

In many applications it is sometimes necessary to inhibit totalization while certain operations are being performed. A high logic level on this input inhibits totalization while the rate indication is still active. This feature is useful during meter proving and may be used with liquid phase detectors.

## CONNECTING AC / DC POWER

NOTE: Connect power only after other connections are finished. Do not touch the live AC power terminals! The unit has been designed with an isolated AC input. Thus, polarity is not a concern for the AC input. The chassis is plastic, therefore earth ground is not used. For D.C. operation, connect + 12V to pin 7 and - D.C. to pin 8.

## CONNECTING SENSOR INPUTS

These diagrams show how to hook a typical input sensor to the unit. The unit supplies an unregulated 12 Volt (50mA) output to power these sensors (Pin 7).

A valid pulse is one which makes a transition from the off-state (0 to 1V) to the on-state (4 to 30V): a positive going edge. The input impedance is 10K Ohms to ground. The unit can be programmed from the front panel for slow switch closure inputs up to 40Hz (select "Lo CPS"), or solid state switches (select "hi CPS") up to 9.99KHz. No rear terminal jumpers are required. Use PNP (sourcing) type pulsers.

## TYPICAL SENSOR HOOKUP

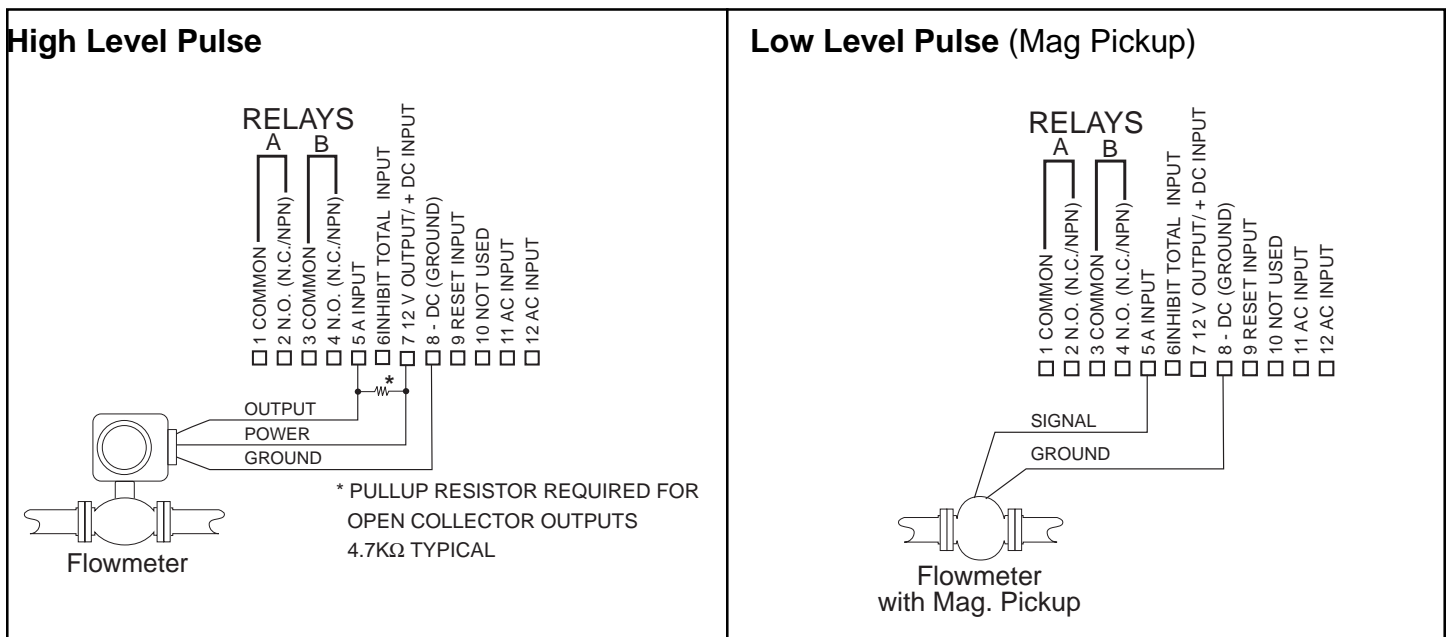

# WHAT CAN YOU VIEW?

Pressing VIEW shows:

- A) The total of input A. If "reset to 0" is selected A counts up, if "set to preset" is selected A will count down.
- B) The rate of input A.
- C)\* The grand total of input A (B Total) which always count up.

NOTE:

\* All decimal points are inverted when "B total" (grand total) is being displayed.

## OUTPUT JUMPER SELECTIONS

FUNCTION	MODIFICATION	
"A" RELAY N.C. OUTPUT	CUT AT "A"	JUMPER "B" TO "2"
"B" RELAY N.C. OUTPUT	CUT AT "D"	JUMPER "E" TO "4"
* "A" PRESET TRANSISTOR (NPN)	CUT AT "A"	JUMPER "C" TO "2"
* "B" PRESET TRANSISTOR (NPN)	CUT AT "D"	JUMPER "F" TO "4"

**BOTTOM VIEW AT TERMINAL**

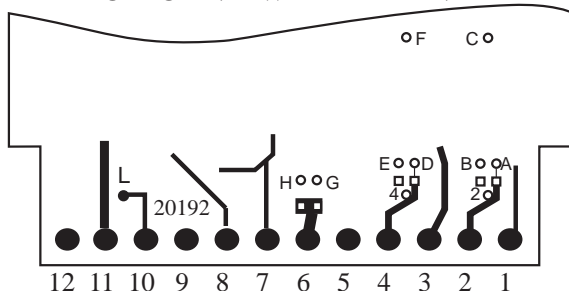

## MILLIVOLT INPUT OPTION JUMPER SELECTIONS

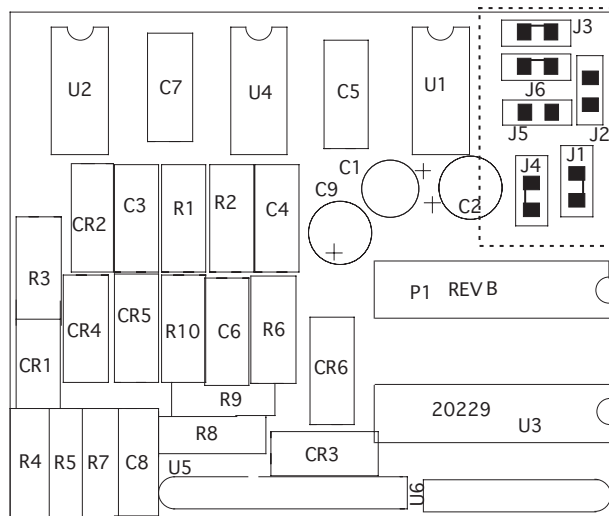

If the unit has the millivolt input bd.# 20229, The A inputs can be solder jumper programmed to accept either a low millivolt or 4-30 V input. The B input should always be set for 4-30 V. Each unit shipped is programmed according to part number. If solder jumpers are made, the part number should be modified to reflect the changes made

C=CLOSE, O=OPEN

	4-30V INPUT	Millivolt INPUT
Input A	J1-O, J2-C, J3-O	J1-C, J2-O, J3-C
InputB	J4-O, J5-C, J6-O	

\* The unit must be removed from the case to access jumpers C & F, all other jumpers can be accessed by removing the plastic extender.

**NOTE:** All three pads at jumpers 2 and 4 are connected.



# OPERATING THE FRONT PANEL

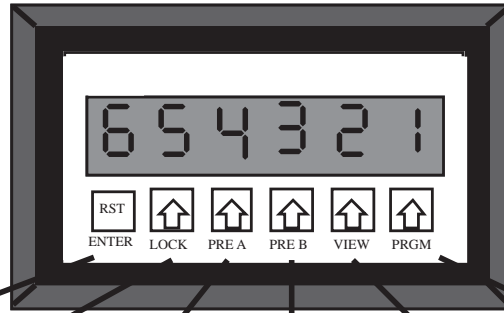

Press to "reset" in operating mode. Press to "enter" in programming mode.

Press to enter lock code for panel lock.

Press to view or change preset A.

Press to view or change preset B.

Press to alternately view A rate, A total or A grand total.

Press to cycle through PROGRAM choices. Press to toggle between choices in program mode.

## PROGRAMMING FLOWCHART

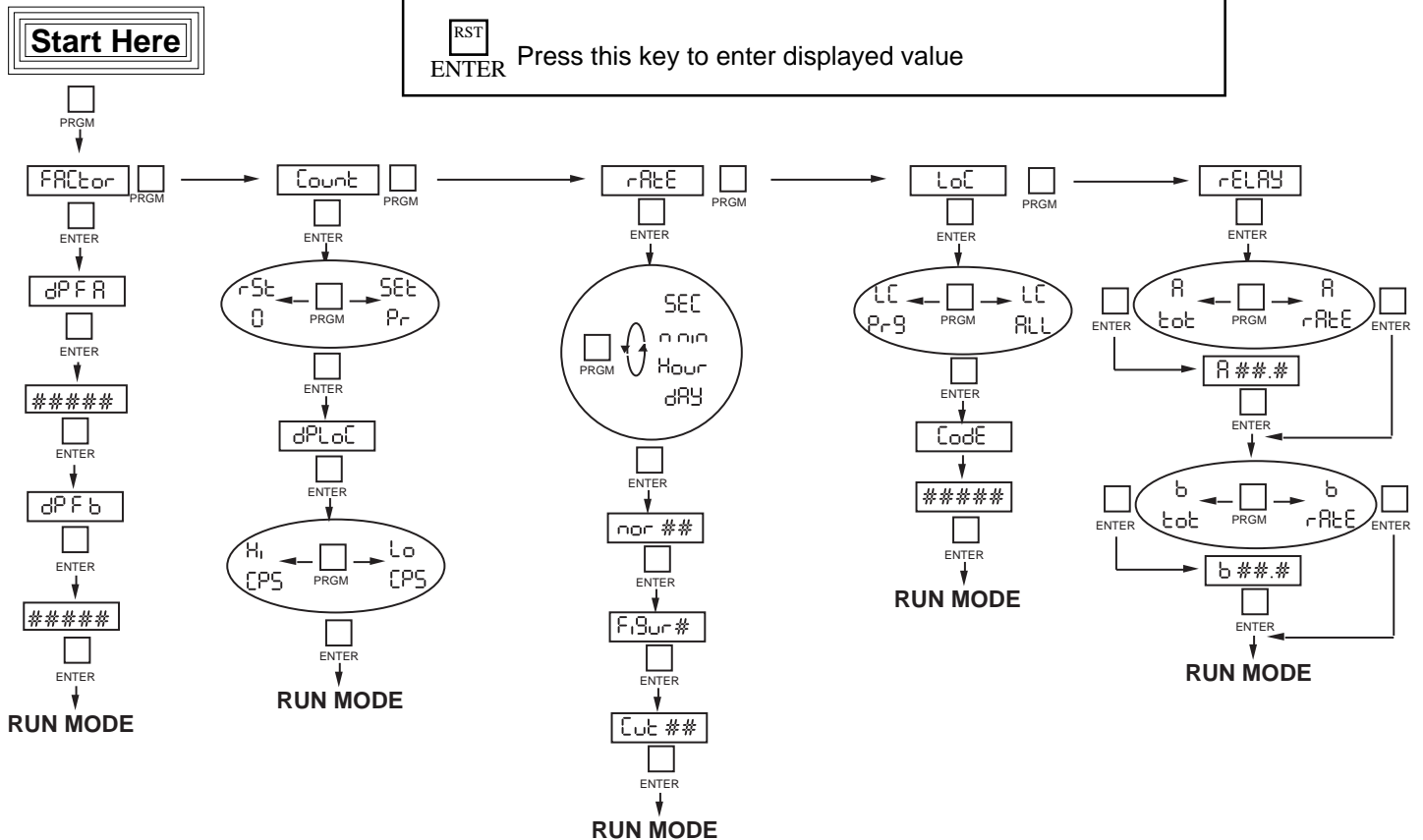
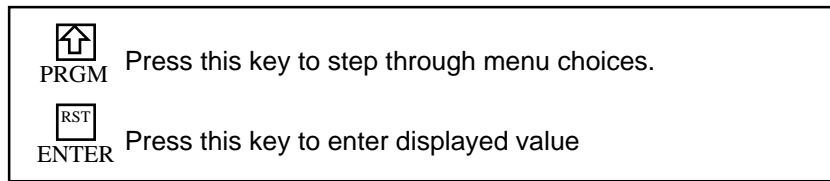

The following is a list of abbreviations as they appear on the display and front panel of the unit.

<u>ABBREVIATION</u>	<u>DESCRIPTION</u>
FRctOr	SCALING FACTOR - Enter the 5 digit dividing scale factor (K-Factor) for the total input (Input A).
dP F A	DECIMAL POINT FOR FACTOR A (K-Factor) - Enter location of decimal point for Scaling Factor A by pressing the button under the digit where the decimal is desired.
dP F b	DECIMAL POINT FOR FACTOR B (offset) - Enter location of decimal point for the Offset Scaling Factor by pressing the button under the digit where the decimal is desired.
COUNT	PORTION OF MENU FOR SETTING COUNTER VARIABLES
rSt 0	RESET TO 0 - Counter will reset to 0. The totalizer will count up from 0.
SEt Pr	SET TO PRESET - Counter will reset to preset A. The totalizer will count down from preset A. The grand totalizer will count up .
dP Loc	DECIMAL POINT LOCATION - Enter desired location of decimal by pushing the button under the digit where the decimal is desired. Changing the decimal will change the decimal location in the totalizer and grand totalizer, but not the rate display.
Hi CPS	HIGH COUNTS PER SECOND - This sets the unit for high count speeds (0-9.99KHz)
Lo CPS	LOW COUNTS PER SECOND – This sets the unit for contact debounce filtering (0-40Hz)
rRtE	PORTION OF MENU FOR SETTING RATE VARIABLES
SEC	RATE PER SECOND - The display will read in rate per second.
min	RATE PER MINUTE - The display will read in rate per minute.
Hour	RATE PER HOUR - The display will read in rate per hour.
dRY	RATE PER DAY- The display will read in rate per day.
nOr ##	NORMALIZING FACTOR - Normalizes (averages) the data being received. Higher settings provide more normalizing (averaging) for a more stable display. Derived from the equation: $\frac{(\text{Old Data} \times \text{"NOR"} + \text{New Data})}{(\text{"NOR"} + 1)}$
FiGur ##	SIGNIFICANT FIGURE - This sets the amount (1-5) of meaningful figures the unit will display. (RATE DISPLAY ONLY). FOR EXAMPLE: If "2" is set as the figure, a rate of 273.45 will be displayed as 270.
Cut	CUTOFF FREQUENCY - Enter the minimum usable frequency for the input device. Any input pulses below this frequency are blocked, the rate reads "0" and totalization stops.
LoC	LOCK - This portion of the menu allows you to: 1) lock the program (presets are still accessible) 2) lock all (presets and program are locked).

- LOCK PROGRAM - This will lock the program and allow the presets to be changed when the unit is in the lock mode.
- LOCK ALL - This will lock the program and the presets when the unit is in the locked mode. The presets can be viewed, but not changed.
- LOCK CODE - This message (code) will flash on display for approximately 3 seconds. It will be followed by a 5 digit number (xxxxx). The number you enter here will be the code to lock and unlock the unit.
- RELAY - This portion of the menu allows you to set your relay operation variables.
- RELAY A FOR TOTALIZER - When this is selected relay A will activate when the total (Total A) has reached Preset A.
- RELAY A FOR RATE - When this is selected relay A will activate when the Rate of input A equals or exceeds preset A.
- RELAY A DURATION - This prompt will appear when "A TOT" is selected. It is the duration which the relay will remain energized (00.1 to 99.9 sec). If 00.0 is selected, the relay will latch until reset. When the duration is not at 00.0, the total will autorecycle.
- RELAY B FOR TOTALIZER - When this is selected relay B will activate when the grand total (Total B) has reached preset B.
- RELAY B FOR RATE - When this is selected relay B will activate when the rate equals or exceeds preset B. The relay will drop out when the rate falls below preset B.
- RELAY B DURATION - This prompt will appear when "B TOT" is selected. It is the duration which relay B will remain energized (00.1 to 99.9 sec). If 00.0 is selected, the relay will latch until reset. When the duration is not at 00.0, the grand total will autorecycle. The autorecycle mode for the grand total may be used to create a relay pulse output.

## WIRING TERMINATIONS

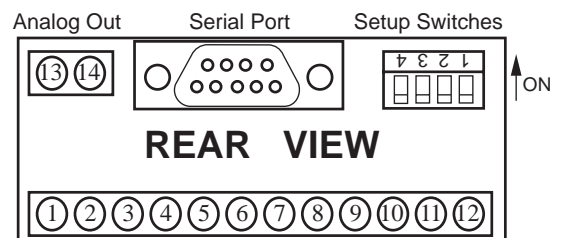
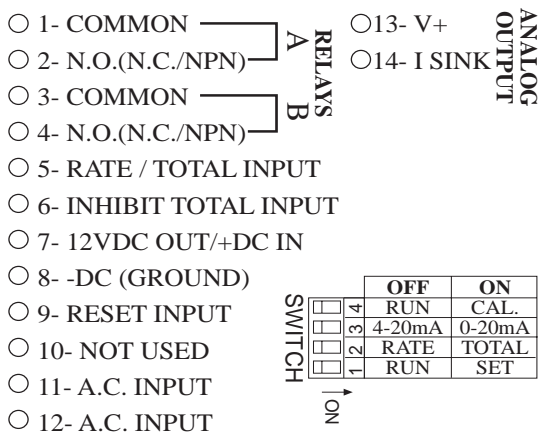

## **CALCULATING SCALE FACTORS**

There are two separate scale factors, associated with pelton wheel flowmeters. The factor ranges from 0.0001 to 99999. Because the "units per second", "minute", "hour" or "day" are field programmable from the keypad, scale factor calculations for the ratemeter are easy.

The A Factor is used for the linearized number of pulses per desired unit of measure.

The B Factor is used for the offset frequency (in Hz).

# PROGRAMMING

**STEP**  
**1**  
**SETTING**  
**SCALING**  
**FACTORS**

<u>PRESS</u>	<u>DISPLAY</u>	<u>REMARKS</u>
<input type="checkbox"/> <b>PRGM</b>	FACtor	This section of the menu is used to set up the scaling factors for rate and total.
<input type="checkbox"/> <b>ENTER</b>	dP F A	This sets the decimal for the primary scaling factor (Factor A). Press the arrow key under the digit where the decimal is desired. To clear the decimal, press the arrow key furthest to the right (PRGM) .
<input type="checkbox"/> <b>ENTER</b>	#####	This is the primary scaling factor (Factor A) for input A. To change, press the arrow key under the digit(s) to change. Press ENTER to enter the displayed value.
<input type="checkbox"/> <b>ENTER</b>	dP F b	This sets the decimal for the offset scaling factor (Factor B). Press the arrow key under the digit where the decimal is desired. To clear the decimal, press the arrow key furthest to the right (PRGM) .
<input type="checkbox"/> <b>ENTER</b>	#####	This is the offset scaling factor (Factor B) for the rate and totalizer. To change, press the arrow key under the digit(s) to change. Press ENTER to enter the displayed value.

**STEP**  
**2**  
**SETTING**  
**THE**  
**COUNTER**

<u>PRESS</u>	<u>DISPLAY</u>	<u>REMARKS</u>
<input type="checkbox"/> <b>PRGM</b>	FRACtor	This section of the menu sets up the counter information.
<input type="checkbox"/> <b>PRGM</b>	Count	
<input type="checkbox"/> <b>ENTER</b>	rSt 0 or SEt Pr	Press the PRGM key to choose RST 0 (reset to 0, count up) or SET PR (set to preset, count down), press the ENTER key to enter the displayed choice.
<input type="checkbox"/> <b>ENTER</b>	dP Loc	This sets the decimal location for the totalizer and grand totalizer. Press the arrow key under the desired digit location. To clear the decimal, press the arrow key furthest to the right. Press the ENTER key to enter the displayed location.
<input type="checkbox"/> <b>ENTER</b>	Hi CPS or Lo CPS	Press the PRGM key to choose HIGH CPS (0-9.99KHz) or LOW CPS (0-40Hz). Press the ENTER key to enter the displayed choice.

STEP  
3  
SETTING  
THE RATE

<u>PRESS</u>	<u>DISPLAY</u>	<u>REMARKS</u>
<input type="checkbox"/> PRGM <input type="checkbox"/> PRGM <input type="checkbox"/> PRGM	FACtor  Count  rAtE	This section of the menu is used to set up the rate information.
<input type="checkbox"/> ENTER	SEC n min Hour dAY	Press the PRGM key to choose SEC (rate per second), MIN(RPM), HOUR (RPH) or DAY (rate per day). Press ENTER to enter displayed choice.
<input type="checkbox"/> ENTER	nor #.#	This sets the normalizing (averaging) factor. Press the arrow keys under the desired digits to change. Press ENTER to enter displayed value.
<input type="checkbox"/> ENTER	FiGur #	This sets the minimum number of significant figures to be displayed. Press the arrow key under the digit to change. Press ENTER to enter displayed value.
<input type="checkbox"/> ENTER	Cut ##	This sets the cutoff frequency 00-99 Hz. Any input frequency below this value will inhibit the totalizer and ratemeter reading. Press the arrow keys under the desired digits to change. Press ENTER to enter displayed value.





**STEP  
5**

**SETTING  
THE  
RELAYS**

**PRESS**                      **DISPLAY**                      **REMARKS**

PRGM                      FACTor

PRGM                      Count

PRGM                      rAtE

PRGM                      LoC

PRGM                      rELAY

This section sets up the relay information.

ENTER                      A tot  
or  
A rAtE

Press the PRGM key to choose A TOT (A assigned to total A) or A RATE (A assigned to rate). Press enter when the desired choice is displayed.

*THIS SELECTION  
WILL ONLY APPEAR  
IF "A RATE" IS  
CHOSEN*

ENTER                      A ##.#

This is the duration (.1 to 99.9 sec) that relay A will remain energized. If 00.0 is selected, the relay will latch until reset

ENTER                      b tot  
or  
b rAtE

Press the PRGM key to choose B TOT (B assigned to grand total B) or B RATE (B assigned to rate). Press enter when the desired choice is displayed.

*THIS SELECTION  
WILL ONLY APPEAR  
IF "B RATE" IS  
CHOSEN*

ENTER                      b ##.#

This is the duration (.1 to 99.9 sec) that relay B will remain energized. If 00.0 is selected, the relay will latch until reset

**SETTING  
THE  
PRESETS**

PRE A                      PrEA  
Followed by  
last PRE A  
entered

PRE A = Preset A; The set point at which output A will trigger. If the displayed value is not the desired preset, press the key(s) under the digit to be changed.

PRE B                      PrEb  
Followed by  
last PRE A  
entered

PRE B = Preset B; The set point at which output B will trigger. If the displayed value is not the desired preset, press the key(s) under the digit to be changed.

# OUTPUT WIRING

The following diagrams detail the connection of the relay and analog output options. Each relay consist of a form A contact (Normally Open). NPN transistor or Normally Closed contacts are available with solder jumpers (see Jumper Options).

## ANALOG OUTPUT

The analog output can be selected to output 4-20 mA or 0-20 mA and can be selected to track the rate or total. Pin 13 supplies 12 to 18V to power the current loop. Pin 14 supplies the current sinking driver. When connecting a strip chart recorder, make connections as follows:

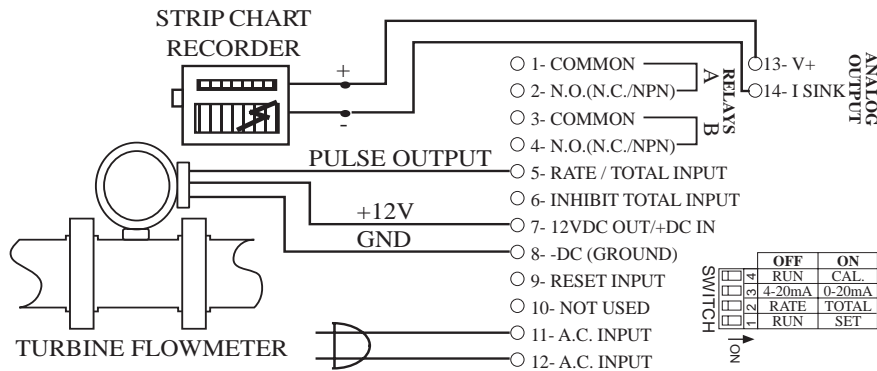

**APPLICATION HINT:** A 0-5 V output can be created by choosing 0-20 mA and using a 250Ω resistor.

## ALARMS

The relays can be used to trigger alarms which warn the operator that the total or rate has exceeded a set amount. The outputs are programmable to be assigned for rate or total. When assigned to the total, the relays can have a user selectable on time (duration) or can be latched until reset.

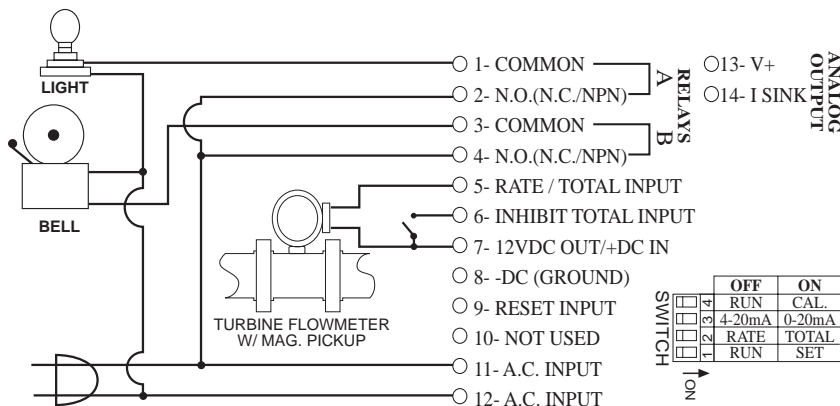

# ANALOG OUTPUT OPTION

## Description:

An optional 4-20mA (0-20mA) output has been added to the Minitrol series. The output can be programmed to track rate or total. This feature is available by adding suffix A to the part number. Connections are via a 2 terminal pluggable screw connector.

## Connections: (see FIG. 1)

PIN13 supplies the 12 to 18 VDC to power the current loop.  
PIN14 is the control sink driver

## Accuracy:

± 0.25% FS

## Compliance Voltage:

3 to 30 VDC

## Setup:

The optional analog output feature uses 4 dip switches on the back for setup. These switches are used as follows:

**SW1** - View or change "set low" and/or "set high" values

**SW2** - Select output for rate or total

**SW3** - Select 4-20mA or 0-20mA

**SW4** - Calibrate the unit.

After the regular parameters shown in the programming flowchart have been set, locate the 4 switches on the back of the unit. (see FIG. 1)

## Switch Settings:

**SWITCH 1:** Enter Analog Low & High (normally off)

Switch 1 is used to load in the low (4mA or 0mA) and/or the high (20mA) output settings. With power on, set switch 1 ON (up).

LOW SETTING is viewed or changed by pressing PRE A. If the displayed value is correct, press ENTER. If not, press buttons A through E to step to the desired value and press ENTER. (disregard the display which will show the last count reading).

HIGH SETTING is viewed or changed by pressing PRE B. If the displayed value is correct, press ENTER. If not, press buttons A through E to step to desired value and press ENTER.

Return switch 1 to OFF (down) position, PRE A and PRE B buttons now function to view or change relay trip values.

## SWITCH 2: Select Total or Rate

SW2 OFF (down): Analog output follows rate

SW2 ON (up): Analog output follows total

## SWITCH 3: Select 4-20mA or 0-20mA

SW3 OFF (down): Selects 4-20mA output range

SW3 ON (up): Selects 0-20mA output range

## SWITCH 4: Calibrate (normally off)

Switch 4 is used for calibration. Calibration is done at the factory and should not be needed (see SWITCH 1 to enter high and low values). If recalibration is desired, a calibrated 20mA ammeter with 1uA resolution is needed. Attach the "+" lead of the meter to pin 13 and the "-" lead to pin 14. Set switch 4 ON (up). The unit will output approximately 20.000mA and a decimal will light in the third position. Read the output using the ammeter. Press PRE A. If the display is the same as the ammeter reading, press ENTER. If not, press buttons A through E to step to ammeter reading and ENTER. (Disregard display which now shows the last count reading with decimal point in third position) Return switch 4 to OFF (down) position.

## RS232 & RS422 Operation:

When the unit is supplied with RS232 or RS422, the analog output "low" and "high" settings can be accessed and changed through the serial port. The codes are as follows:

**AL** Unit will display (transmit) analog out "low" value.

**AL(S)XXXXX** Unit will load analog out "low" with entered number. (S) = space

**AH** Unit will display (transmit) analog out "high" value.

**AH(S)XXXXX** Unit will load analog out "high" with entered number. (S) = space

FIG. 1

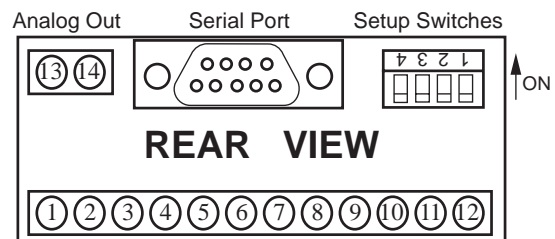

## Typical Wiring:

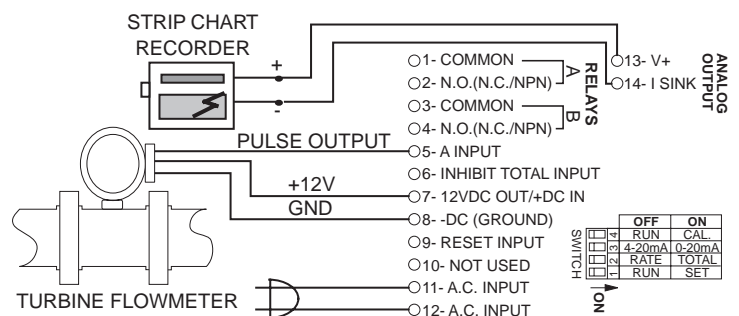

# INTERFACE CARD RS 232/422 OPERATION

## **RS 232/422 SET-UP:**

All serial communication mode changes must be done through serial communications. Mode changes cannot be done through the front panel. To initialize the unit, place a jumper between pin 7(+12V)[bottom board] and pin 1(init)[DB-9 connector] on initial power up. The unit defaults to: 300 baud rate, "MARK" parity and device number 01. To enter the program mode you must set your terminal for 300 baud rate and "MARK" parity. Next, type D1(s), (s)= **space bar**. The unit will echo back "DEVICE #1:". Now type EP (enter program) and a carriage return (enter). The unit will echo back "PROGRAM SETTING". You are now in the programming mode.

## **SETUP PROCEDURE:**

The following sections consist of the communications setup options as they appear in the menu. (If you wish to exit the program mode, at any time you can hit the "escape key" (Hex Code: 1B) and the unit will save the changes made but not effect the remaining data values.) When each section of the setup menu is displayed, the current data will appear in the < > signs. If you wish to change the data, type in the number of the desired choice and press return (enter). If you wish to keep the current data, simply press return.

## **DEVICE NUMBER:**

Each unit in the multidrop installation must be assigned it's own device number (1 to 99). Zero is reserved for a dedicated hook-up to only one terminal, and it's transmit output line remains in an "on" active state. The device number is entered in the program mode. The unit will prompt you:

DEVICE# <XX>?

If XX is the desired device number press return (enter), if not enter the desired number after the question mark and press return (enter).

## **BAUD RATE:**

The baud rate is the speed at which data is transmitted, expressed in bits per second. Baud rates of 300, 600, 1200, 2400, 4800 or 9600 are available. When in the baud rate section of the menu, the unit will list :

BAUD RATES:

1:300 2:600 3:1200

4:2400 5:4800 6:9600

then prompt you:

BAUD RATE <300>?

Press return (enter) if this is the desired baud rate or enter the assigned number of one of the six possible baud rates. If an invalid baud rate is entered the unit will prompt you to choose another baud rate. This will occur until a valid baud rate is entered or escape is pressed.

## **PARITY:**

Parity is a bit of information that is inserted before the stop bit and is used to help check if the data transmission is correct. When setting the parity you may select "ODD" (parity bit is logic 0 if total number of logic 1's in the first seven data bits is

odd), "EVEN" (parity bit is logic 0 if total number of logic 1's in the first seven data bits is even), "MARK" (parity bit is always logic 1 - High / Mark) or "SPACE" (parity bit is always logic 0 - Low / Space). If a "MARK" parity is chosen, it will appear that two stop bits are used. Use the "MARK" parity with terminals using parity "OFF" or "NONE". These terminals ignore the parity. The unit does not check the parity but does transmit the parity chosen. When setting the parity, the unit will print:

PARITIES:

MARK-0 SPACE-1 EVEN-2 ODD-3

Then the unit will prompt you:

PARITY<MARK>?

If this is the desired parity press return (enter), if it isn't enter the number of the desired parity then press return (enter).

## **STROBE LIST:**

The serial interface card is also equipped with a strobe line. When the strobe line is triggered, a chosen set of data will be transmitted to be displayed or printed. The selections for the display list are entered in the program mode. Enter "1" to add selections to the list and enter "0" to delete selections from the list. The seven available items for the strobe display list are: (1) Preset A, (2) Preset B, (3) K-Factor A, (4) K-Factor B, (5) Rate of A, (6) Count A, (7) Count B. When setting the strobe list the unit will print :

ENTER STROBE LIST:

DO NOT DISPLAY-0 DISPLAY-1

The unit will prompt you:

PRESET A<DISPLAY>?

PRESET B<DISPLAY>?

K-FACTOR A<DISPLAY>?

K-FACTOR B<DISPLAY>?

RATE<DISPLAY>?

COUNT A<DISPLAY>?

COUNT B<DISPLAY>?

If the above choices are entered, when the strobe line is triggered (3-30V positive pulse) the unit will transmit:

DEVICE# 1:

PA XXXXX

PB XXXXX

KA XXXXX

KB XXXXX

DR XXXXXX

DA XXXXXX

DB XXXXXX

(SEE COMMANDS BELOW FOR DESCRIPTION OF COMMAND CODES).

Each time the strobe line gets triggered the unit will transmit this data unless the program mode is entered and the strobe list altered.

After these four items have been entered they will remain unaltered unless the program mode is entered again and the values changed. The unit is now set and must be addressed by it's device number to come on line again.

**SERIAL INPUT COMMANDS:**

To get a unit on line you must address it by it's device number. This is done by typing DXX(S), XX= device number. The unit comes on line and echoes back DEVICE# XX. Insure that "DEVICE# XX:" is received before requests are sent. The unit is now ready to receive a command or string of commands separated by a space. A carriage return (enter) will enter the commands and processing of requests begins. The carriage return (Hex Code "D") puts the unit "off line" after data is processed.

**COMMANDS:**

- EP.....Unit will enter program mode.
- DA.....Unit will display (transmit) Total A.
- DB.....Unit will display (transmit) Total B (grand total).
- DR.....Unit will display (transmit) rate A.
- KA.....Unit will display K-factor A.
- †\*KA(S)XXXXX....Unit will load K-factor A with entered number.
- KB.....Unit will display K-factor B
- †\*KB(S)XXXXX....Unit will load K-factor B with entered number.
- PA.....Unit will display Preset A.
- †PA(S)XXXXX....Unit will load Preset A with entered number.
- PB.....Unit will display Preset B
- †PB(S)XXXXX....Unit will load Preset B with entered number.
- RA.....Total A will reset
- †\*RA(S)XXXXXX...Unit will set Total A to entered number.
- RB.....Total B (grand total)will reset.
- †\*RB(S)XXXXXX...Unit will reset Total B (grand total) to entered number.

**\*THE UNIT WILL RECOGNIZE A DECIMAL IF ONE IS PLACED IN ANY OF THESE DATA VALUES.**

**†THE UNIT WILL ONLY RECOGNIZE THE LAST FIVE DIGITS ENTERED (SIX DIGITS FOR RA & RB).**

The following is an example of requests and responses:

<u>Transmit from terminal</u>	<u>Receive from unit</u>
	(s)=Space
D5(s) [Unit #5 Activated]	DEVICE# 5:
PA(s)12345(s)PA	PA 12345 PA
KA(s)1576(s)KA	KA 1576 KA
KB(s)6751(s)KB	KB 6751 KB
RA(s)RB[RETURN]	RA RB
(UNIT PRESETS AND A & B K-FACTORS ARE SET AND BOTH TOTALIZERS ARE RESET)	
12345	
	1576
	6751

**SERIAL INTERFACE OPERATION:**

Data is received and transmitted over standard EIA RS232 or RS422 levels. Each ten bit character is made up of a start bit, seven bit ASCII code, a parity bit and a stop bit. Device number, baud rate, parity and strobe list are entered in the program setup mode and will remain in memory even if power is lost.

The input impedance of RS232 is 3KΩ to 7KΩ worst case. The terminal addressing the unit must be capable of driving all loads in the loop. The input impedance of RS422 is much higher and there should be no problem driving as many as 99 units. The transmit line remains in a high impedance "off" state until addressed. Only one unit is to be on line at a time!!! More than one unit on line could damage the unit or corrupt the transmitted data.

When the unit is active (on line) it will operate in a full duplex, echo back mode, so that data sent from the terminal will be transmitted back for verification. When the unit is "on line", use the proper serial transmit commands to request data or set a new value. Up to 80 characters of data can be linked together and transmitted to the unit in a string as long as there is a space between the commands. If an error is made, a correction can be made by back spacing and retyping correct data before the return (enter) is sent. Once a return (enter) is sent, the unit begins processing the data and will transmit the requested data on a non-priority basis over the data transmit line. A keypad entry or incoming data will halt the data communication cycle. Therefore, there should be a pause after data is requested to insure that all data has been transmitted before making another request or addressing another unit. If the unit is not busy, it should not take longer than 300 msec to process each request. To find the cycle time to process and transmit a request, calculate the bit transmit time by using this formula:  $[(1 \div \text{baud rate}) \times (80) + .005] \times \text{number of requests made}$ . This time will be extended if the unit must service the front keypad. If transmission has not started within two seconds after data is requested, it can be assumed that there is a problem. The unit transmits a carriage return and line feed after each data value. Any new communication must be started with DXX(S) (device number and space).

**RS232/RS422 - IBM-PC INTERFACE:**

The following program is for IBM basic to set up RS232/RS422 on serial port (#1) at 300 baud. Run this program after connecting the serial interface connections.

```

10 SCREEN 0,0:WIDTH 80
20 CLS:CLOSE
30 OPEN "COM1:300,n,7,1,CS,DS,CD" AS #1
40 ON ERROR GOTO 110
50 B$=INKEY$
60 IF B$< >" THEN PRINT #1,B$;
70 IF EOF (1) THEN 50
80 A$=INPUT$ (LOC(1),#1)
90 PRINT A$;
100 GOTO 50
110 RESUME

```

# RS232 / RS422 WIRING

## COMPUTER HOOKUP:

**RS 232:** When connecting the unit to a computer with RS 232 communication, only three connections are needed. These connections are: Receive data, Transmit data and Ground. The connections should be made as follows:

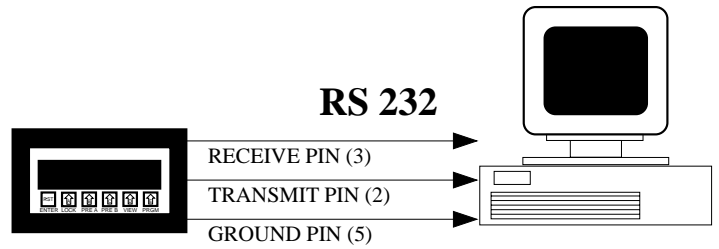

## DP -9 CONNECTOR

Transmit data (pin 2)  
Receive data (pin 3)  
Ground (pin 5)

## COMPUTER

Receive data  
Transmit data  
Ground

**RS 422:** When connecting the unit to a computer with RS 422, five connections are needed. These connections are: Receive data A (+), Receive data B (-), Transmit data A (+), Transmit data B (-) and Ground. The connections should be made as follows:

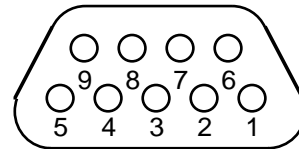
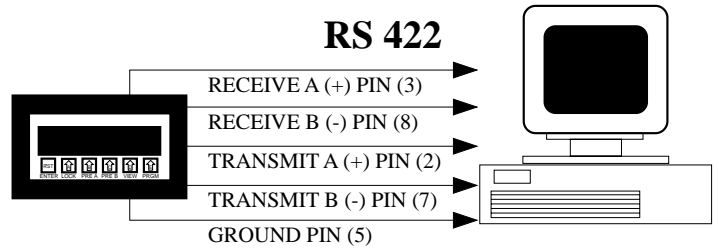

## DP -9 CONNECTOR

Transmit data A(+) (pin 2)  
Transmit data B(-) (pin 7)  
Receive data A(+) (pin 3)  
Receive data B(-) (pin 8)  
Ground (pin 5)

## COMPUTER

Receive data A(+)  
Receive data B(-)  
Transmit data A(+)  
Transmit data B(-)  
Ground

## RS 232

1. INITIALIZE
2. TRANSMIT
3. RECEIVE
4. N/C
5. GROUND
6. STROBE
7. N/C
8. N/C
9. N/C

## RS 422

1. INITIALIZE
2. TRANSMIT A (+)
3. RECEIVE A (+)
4. N/C
5. GROUND
6. STROBE
7. TRANSMIT B (-)
8. RECEIVE B (-)
9. N/C

## PRINTER HOOKUP:

When connecting the unit to a printer, you must first program the desired baud rate, parity and strobe list with a computer. After the unit is programmed it can be connected to the printer. Connect the transmit line(s) of the unit to the receive line(s) of the printer and be sure that both devices have common grounds. When the strobe line is triggered the unit will transmit the selected strobe list which you had previously programmed.

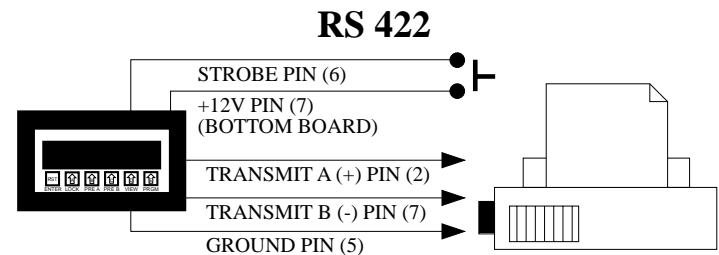
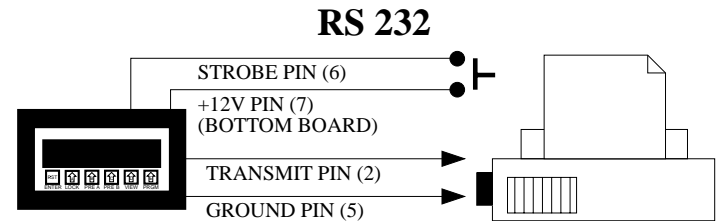

# TROUBLESHOOTING GUIDE

<u>PROBLEM</u>	<u>POSSIBLE CAUSES</u>	<u>SOLUTIONS</u>
Power is applied to unit but the display does not light.	1. AC or DC power wiring is incorrect.	1. Recheck power wiring
Unit works, but occasionally the display freezes or skips counts.	1. Line noise is affecting the processor due to a current spike or surge.	1. Use a different power supply or install a surge suppressor.
Input signal is connected but the unit does not totalize or display rate.	1. Input wiring is incorrect. 2. Scale factors are incorrect. 3. Transmitting device is defective. 4. Wrong debounce filtering selected. 5. Minitrol is defective. 6. Cutoff frequency set too high.	1. Recheck input wiring. 2. Recheck scale factors and factor calculations. 3. Replace transmitting device. 4. Recheck debounce filtering selection "hi cps" or "lo cps". 5. To confirm set Factor A at "1" & Factor B at "0", Cut to "0" Connect a wire to pin #7 and touch it to pin # 5 (input A). Each time pin #5 is touched Total A should count once. If not, call factory for RMA. 6. Recheck cutoff frequency setting
Rate is displaying: r FFFFF.	1. The unit is trying to display a number which it can't (too large). 2. Line noise affected unit on power up.	1. Check scaling factor, if it is correct, lower the number of significant figures. 2. Reprogram the unit and be sure to enter a decimal (enter one and re move it if a decimal is not desired).
Relays are not activating properly.	1. Wrong relay duration. 2. Relay set for wrong activation i.e. total instead of rate.	1. Recheck programmed relay duration. 2. Recheck programmed relay activation mode.
Totalizer resets before reaching 999999.	1. Relay duration is set at a value other than 00.0. This causes the total to auto-reset at the preset.	1. If relay outputs are not being used, set the relays for rate. 2. Set the relay durations to 00.0.

## **NOTE TO OUR CUSTOMER**

KEP is dedicated to providing complete customer service and customer satisfaction. If you have any comments or criticisms about how to improve this manual, please make a note of the problem/improvement and notify us. We are always open to new ideas and improvements. So please let us know your ideas and comments.

Call us toll free: 800-631-2165

### **WARRANTY**

This product is warranted against defects in materials and workmanship for a period of two (2) years from the date of shipment to Buyer.

The Warranty is limited to repair or replacement of the defective unit at the option of the manufacturer. This warranty is void if the product has been altered, misused, dismantled, or otherwise abused.

ALL OTHER WARRANTIES, EXPRESSED OR IMPLIED, ARE EXCLUDED, INCLUDING BUT NOT LIMITED TO THE IMPLIED WARRANTIES OF MERCHANTABILITY AND FITNESS FOR A PARTICULAR PURPOSE.