

AMP-2

Dual Preamp & Signal Conditioner for Magnetic Pickups

Installation and Operating Instructions



KESSLER-ELLIS PRODUCTS

10 Industrial Way East

Eatontown, NJ 07724

800-631-2165 • 732-935-1320

Fax: 732-935-9344



<http://www.kep.com>



Contents

Installation	1
Dimensions.....	2
User Electrical Wiring Installation	3
Wiring Drawing.....	3
Typical Application	3
Simplified Block Diagram.....	3
Startup and Commissioning	4
Operation	4
Specifications	5
Description	5
Environmental	5
Power Input:	5
Magnetic Pickup.....	5
Pulse Output.....	5
Listing for Ex-Proof Option	5
Enclosure.....	5
Decoding Part Number	5
Trouble Shooting.....	6
Recommended Spare Parts	6

Installation

The installation wiring and related workmanship must be in accordance with the National Electrical Code.

DC Power to the unit should be turned off during installation and systematically applied as described in the Start-Up and Commission section

If the surrounding area contains flammable materials then suitable safety precautions need to be observed when carrying out the installation.

The AMP-2 is commonly provided in a variety of enclosures. The style of the enclosure has been specified when ordering. (See ordering information for details.) In addition the Amp-2 may have been supplied with additional accessories such as a flow meter mounting kit (TFM-MK-XXX) and/or an input signal cable for the magnetic pickup (CA-TFM-2-18-FL). See illustrative photos below for details.



See the dimension drawings for the details of the mechanical installation for your unit. The following summarizes the installation of the signal cable, mounting kit, and AMP-2 on top of a turbine flow meter in a typical installation.

The signal cable (For example CA-TFM-2-18-FL) is first plugged into the magnetic pickup of the turbine flowmeter.

The union of the mounting kit is taken apart. A portion of the kit mounts to the turbine flow meter. The other portion screws into the housing for the AMP-2.

The signal cable is fed through the union and into the housing for the AMP-2.

The two halves of the union are joined and tightened with convenient service access to the enclosure provided.

In some other installations it may be necessary to remove the printed circuit board from the enclosure during the mechanical assembly of threaded connections.

In some other installations of the AMP-2-O, only the circuit card assembly is provided and the enclosure and its mounting provided by the customer (or other OEM).

It is important to consider mounting and using suitable sealing fixtures for cables run to the enclosure to prevent the accumulation of condensate within the enclosure.

Verify the enclosure cover seals are present to prevent entry of moisture within the enclosure.

Desiccants are recommended to prevent condensate from forming on the circuit assembly in cold weather.

After the mechanical assembly has been completed proceed to the Electrical Wiring Installation.

Dimensions

OEM Mount (Mounting option 0):

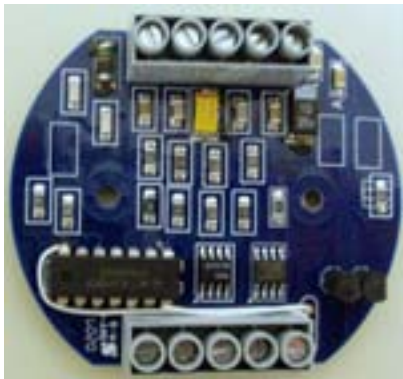
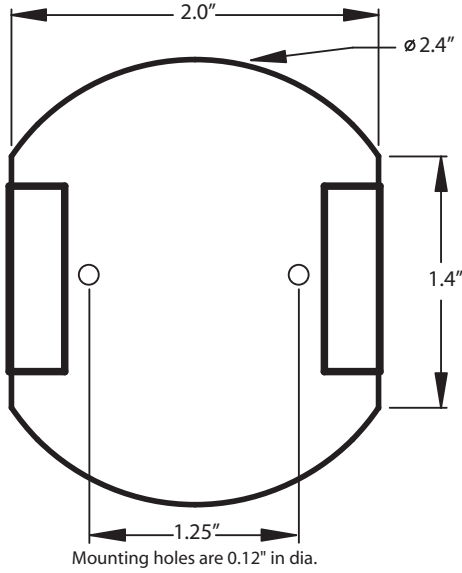

NEMA4 Wall Mount (Mounting option 1):

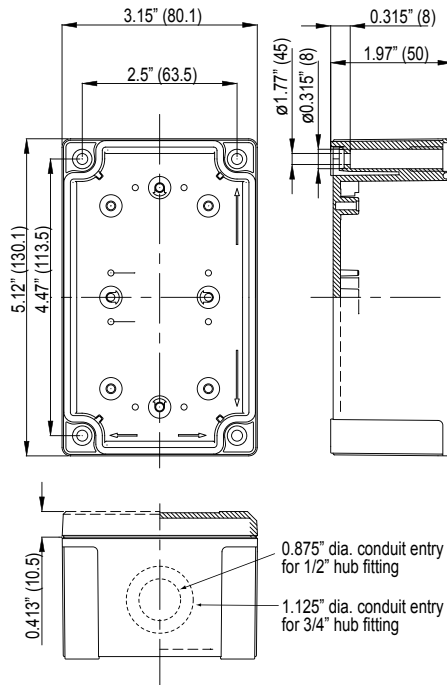

Explosion Proof (Mounting option 2):

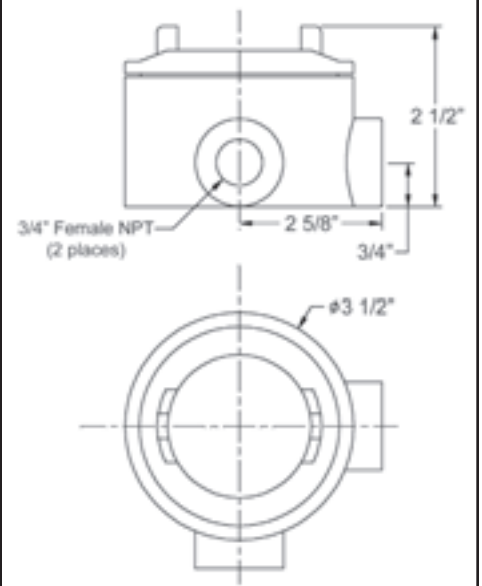

User Electrical Wiring Installation

The AMP-2 contains two input channels that are intended to be connected to magnetic pickups. A high level pulse is provided on each of the channel outputs. The AMP-2 is intended to be powered by a DC Voltage of between 8.5 and 30 Vdc.

The two channels can be used in a variety of ways to suit the intended application:

1. One Magnetic Pickup wired to Channel A with a pulse output on Channel A (Channel B is a Spare)
2. One Magnetic Pickup wired to channels A and B to provide two pulse outputs on Channel A and B
3. Two Magnetic Pickups (one on channel A the other on channel B)

The magnetic Pickup for Channel A is wired to terminals 1 and 2. Note that there is normally no polarity on magnetic pickup sensors. A shield may be connected to terminal 3 if desired. It may be necessary to install a ground on either terminal 3 or 7 or 9 if shields are used .

The magnetic Pickup for Channel B is wired to terminals 4 and 5 if used. Note that there is normally no polarity on magnetic pickup sensors. A shield may be connected to terminal 3 if desired. It may be necessary to install a ground on either terminal 3 or 7 or 9 if shields are used .

The pulse output for Channel A is wired to terminals 8 (+) and 9(-). A shield may be connected to terminal 9 if desired. It may be necessary to install a ground on either terminal 3 or 7 or 9 if shields are used .

The pulse output for Channel B is wired to terminals 10 (+) and 9(-). A shield may be connected to terminal 9 if desired. It may be necessary to install a ground on either terminal 3 or 7 or 9 if shields are used .

DC Power is wired to terminal 6(+) and Terminal 7(-).

Wiring Drawing

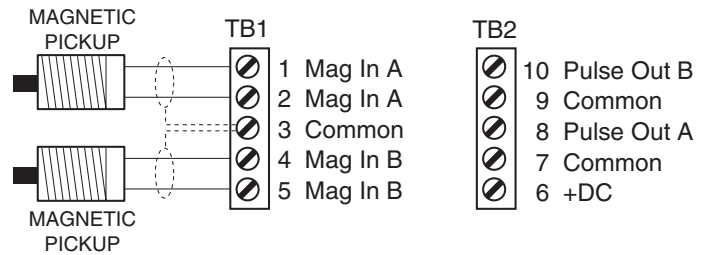

Typical Application

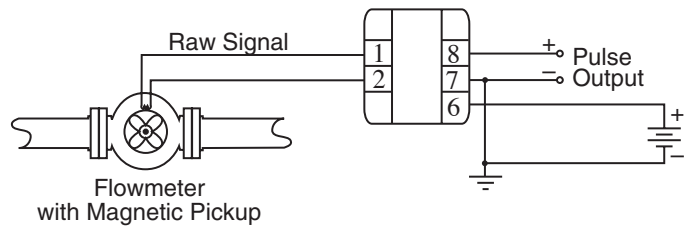

Simplified Block Diagram

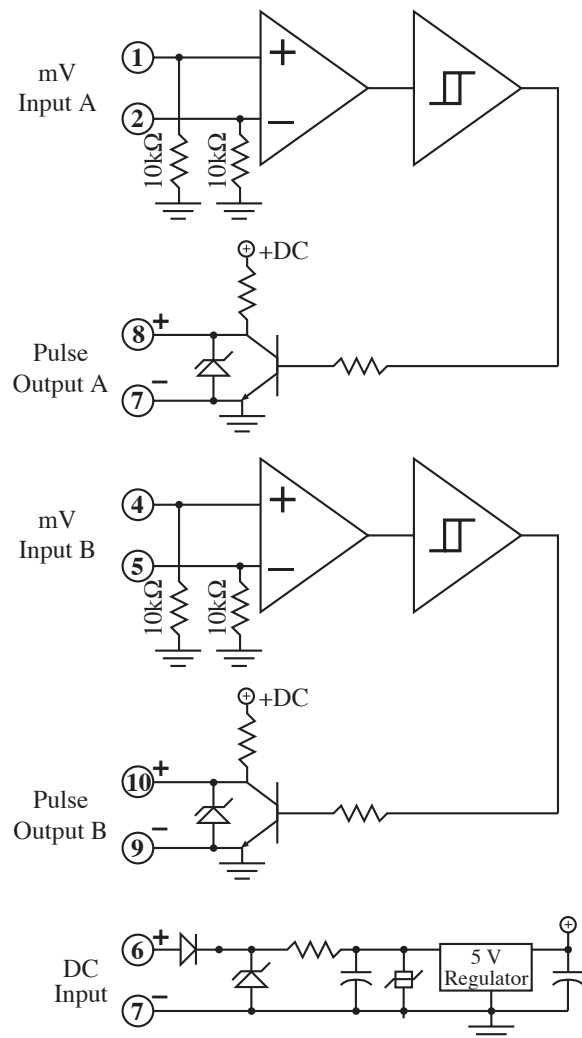

Startup and Commissioning

Verify that the enclosure rating is suitable for the intended installation site. Verify workmanship.

Verify the following wiring connections before applying the DC Power Voltage to the unit:

1. A DC Supply with a Voltage between 8.5Vdc and 30 Vdc is connected 6 (+) and 7 (-)
2. The magnetic pickup for sensor on channel A input is wired to terminals 1 and 2 (no polarity required)
3. The pulse output for channel A is wired to terminals 8 (+) and either 7 or 9 (-)
4. Shields may optionally be connected on either 3 or 7 or 9
5. Earth ground may be required on either 3 or 7 or 9.

If Channel B is being used the following connections should be verified:

6. The magnetic pickup for sensor on channel B input is wired to terminals 4 and 5 (no polarity required)
7. The pulse output for channel B is wired to terminals 10(+) and either 7 or 9 (-)
8. Shields may optionally be connected on either 3 or 7 or 9
9. Earth ground may be required on either 3 or 7 or 9.

Apply the DC Power.

There should be no false pulse output present during periods of no flow. The receiving equipment should not register false signals under these conditions.

The receiving equipment should properly register flow once a signal is generated by the magnetic pickup.

Operation

The operation of the AMP-2 is automatic after the installation is complete. The output should generate a frequency pulse output signal in response to the low level sinusoidal milli-volt signal from the magnetic pickup.

Normal operation can be assumed when the following conditions have been verified:

1. There is no false output pulse signal during periods of no flow (no intended input signal present).
2. There is a valid frequency pulse output signal at the minimum flow rate in the application
3. There is a valid frequency pulse output signal at the maximum flow rate in the application

Specifications

Description

The KEP AMP-2 is a two channel amplifier for use with magnetic pickups. It amplifies and squares the low level signals from a magnetic pickup to drive any ratemeter, totalizer or controller. The unit operates from 8.5 to 30 VDC. It has a 10K pullup resistor attached to the open collector output and sinks a minimum of 20 mA to less than 1 V from a maximum of 30 VDC. It is available in OEM (PC board only), NEMA4X enclosure or in a rugged explosion proof housing with screw terminals for easy installation. Operating temperature is -40° to 65°C.

Note: The low voltage line from the magnetic pickup to the AMP-2 should be less than 10 ft. in length, shielded and isolated from relays, solenoids or other sources of electrical noise (let the output line make the long run). If the input is too sensitive, lower the 10K input impedance by adding a 1K ohm resistor across TB1, pins 1 and 2, 4 and 5 to increase noise immunity.

Environmental

TEMPERATURE: -40° to 65°C

HUMIDITY: 0-95% Noncondensing

Power Input:

Input Voltage Range: 8.5 to 30 VDC

Supply Current: 25 mA (nominal)

Reverse Polarity Protection

Transient Protection: Surge Suppression Clamp at 36V

Magnetic Pickup

Sensitivity: 10 mV p-p

Bandwidth: 0-4000 Hz

Over Voltage Protection to 30 VDC

10 KΩ input resistance

Type: Differential Preamplifier

Pulse Output

Maximum Voltage: DC Input

Maximum Current: 100 mA @ .7V max

Reverse Polarity Protection

Overcurrent Protection

Surge Suppression Clamp at 36V

Listing for Ex-Proof Option

CSA for Canada and USA

Class I Division 1 Groups B,C,D

Class II Division 1 Groups E,F,G

Class III

Enclosure: Type 4X

Enclosure

0- OEM No Enclosure; for use in OEM mounting applications

1- NEMA4X NEMA 4X Wall Mount Enclosure

2- Ex Proof (FM/CSA), NEMA 4X, Die Cast Aluminum, 3 Port Instrument Housing With Blind Cover

Decoding Part Number

Ordering Information

EXAMPLE: AMP2 1 HF2

Series: _____

Mounting: _____

0 = OEM (board only)

1 = NEMA 4X Box

2 = Explosion Proof Housing

Mounting Options for NEMA 4X: _____

H2 = 0.875" Hole for NEMA4X mounting style

HF2 = 0.5" Female NPT Hub fitting for NEMA4X mounting style

H3 = 1.125" Hole for NEMA4X mounting style

HF3 = 3/4" Female NPT Hub fitting for NEMA4X mounting style

Additional conduit entry configurations are available, consult factory.

Accessories:

TFM-MK -1 = Turbine Flow meter Mounting Kit for flow meters with a 1" Male NPT riser

TFM-MK -3/4 = Turbine Flow meter Mounting Kit for flow meters with a 3/4" Male NPT riser

CA-TM-2-18-FL = 18" Turbine Flow meter Cable Assembly

Trouble Shooting

Problem Observation	Cause	Corrective Action Steps
No Pulse Output	No Dc Power	Verify Polarity and Voltage between 6 (+) and 7 (-)
	No input from Sensor	Check Coil Resistance of pickup Check Isolation Resistance of pickup
	Pulse Input Wiring	Check cable connections to pickup
	Pulse Output Wiring	Check cable connections to pulse output
False 60Hz Output	60 Hz Pickup	Install Ground to 3 or 7 or 9 Install 1 k Ohm resistor 1 to 2 and 4 to 5 Use shielded cables
Other False Output	Missing Ground	Add ground to terminal 3 or 7 or 9
	Cable Cross Talk	Use Sheilded Cables Separate cables
	AC Magnetic Field	Install Ground to 3 or 7 or 9 Install 1 k Ohm resistor 1 to 2 and 4 to 5 Relocate Flow meter

Recommended Spare Parts

A spare AMP-2-0 is the only recommended spare part.