

Input Ranges From $\pm 3^\circ$ to $\pm 90^\circ$ Rugged, High Precision, Low Cost, Dual-Ended Power Input Inclinometer

The Jewell **Emerald Series** inclinometer is a low cost, high precision inclinometer designed with higher accuracy sensor than comparable MEMS devices. Applications include robotics, construction equipment, industrial measurement and control, and precision machining. All Emerald Series inclinometers are RoHS compliant.

Features

- Extremely Rugged
- Lower Cost than Traditional Forced-Balance Inclinometers
- High Accuracy
- Greater Precision than MEMS Technologies
- $\pm 5V$ DC Output
- Dual Power Input
- RoHS Compliant

Applications

- Aerospace
- Military
- Robotics
- Academic Research
- Geotechnical Monitoring
- Track Monitoring and Testing
- Vehicle Wheel Alignment



Outline Diagram

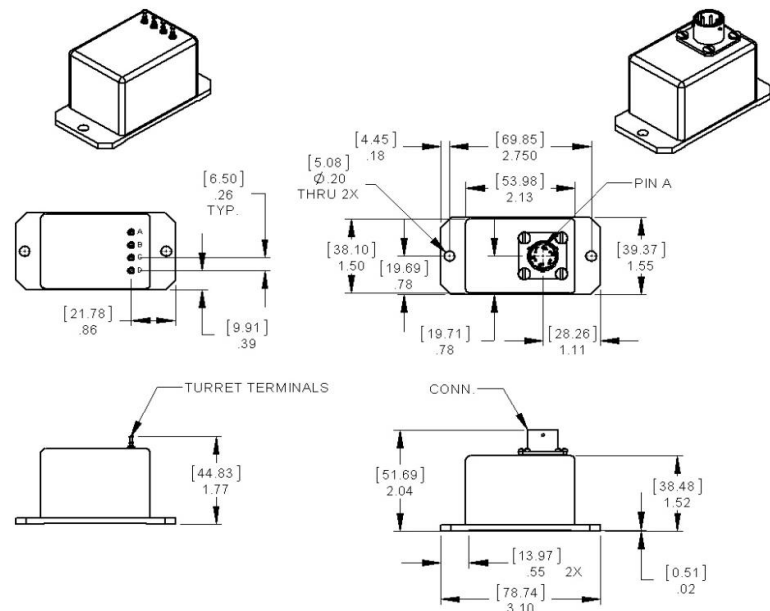

Dimensions in inches [mm]

Pin Out (Options: C-connector, P-Pin)

Pin Option		Connector Option	
A	Positive Input Power	A	Positive Input Power
B	Power/Signal Common	B	Power/Signal Common
C	Negative Input Power	C	Negative Input Power
D	Signal	D	Signal
		E	N/C
		F	N/C

Performance Specifications

STATIC/DYNAMIC

Input Range, °:	±3	±14.5	±30	±45	±60	±90
Full Range Output (FRO -Note 1) VDC ±0.5%:	±5	±5	±5	±5	±5	±5
Nonlinearity (Note 2) % FRO maximum:	0.05	0.02	0.02	0.02	0.04	0.05
Scale Factor, Volts/g, nominal:	95.5	20.0	10.0	7.1	5.8	5
Scale Factor Temp. Sensitivity (SFTS), PPM /°C maximum:	100	100	100	100	100	100
Bandwidth (-3 dB), Hz nominal:	5.0	5.0	5.0	5.0	5.0	5.0
Output Axis Misalignment, ° maximum:	0.25	0.50	0.50	0.50	0.50	0.50
Pendulous Axis Misalignment, ° maximum:	0.25	0.50	0.50	0.50	0.50	0.50
0° Output, Volts range:	±0.05	±0.05	±0.05	±0.05	±0.05	±0.05
0° Output Temp. Sensitivity, Volts /°C maximum:	0.0070	0.0017	0.0010	0.0008	0.0007	0.0007
Resolution and Threshold (Note 3), μradians maximum:	1	1	1	1	1	1

ELECTRICAL

Number of Axes:	1
Input Voltage Range, (VDC):	±12 to ±18
Input Current, mA, max:	40
Output Impedance, Ohms, nom:	10
Noise, Vrms, maximum:	0.002

ENCLOSURE

Seal:	IP65
-------	------

ENVIRONMENTAL

Operating Temp Range:	-55°C to +85°C
Storage Temp Range:	-60°C to +90°C
Shock:	500g, 1 msec, ½ sine

Notes: Note 1: Full Range is defined "from negative full input angle to positive full input angle."

Note 2: Nonlinearity is specified as deviation of output referenced to theoretical sine function value, independent of misalignment.

Note 3: Full Resolution is achieved with noise reduction techniques.

Custom Capabilities

- 15 to 30V single-ended input option available
- Pigtail and Connector alternative options available
- Custom ranges and bandwidths available

How to Order

Connector Version		Pin Version	
Model #	Part #	Model #	Part #
SMIC-D-3	02550308-001	SMIP-D-3	02550307-001
SMIC-D-14.5	02550308-002	SMIP-D-14.5	02550307-002
SMIC-D-30	02550308-003	SMIP-D-30	02550307-003
SMIC-D-45	02550308-004	SMIP-D-45	02550307-004
SMIC-D-60	02550308-005	SMIP-D-60	02550307-005
SMIC-D-90	02550308-006	SMIP-D-90	02550307-006