

Part of our RailStar Series of products, the LCF-2530 is ideal for Rail Maintenance of Way applications

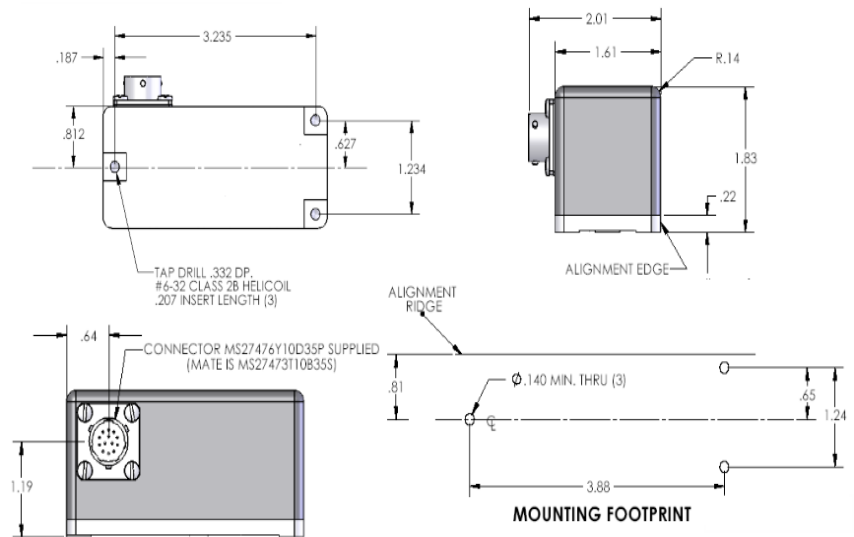

The Jewell **LCF-2530** Series is a dual axis version of the rugged, high accuracy LCF Series. The design of the LCF-2530 was optimized to provide the high suspension, servo technology in a small and convenient package for applications requiring a compact dual axis solution.

## Outline Diagram



## Features & Benefits

- $\pm 0.5g$  to  $\pm 2.0g$  Full Range
- Filtering 5-100 Hz Bandwidth
- Exceptional Bias & Scale Fctr
- High Level  $\pm V$  dc Output
- 1,500g Shock Capability
- Built In Temperature Sensor
- Fluid Damped

## Applications

- Railcar Accel/Decel Control
- Train Performance Testing
- Active Damping
- Rail Car Harshness (NVH)
- Manual Rail Measurement

## Pin Out (Options: C-connector, P-Pin)

PIN-OUT	
1	+12 to +18 VDC
2	-12 to -18 VDC
3	COMMON
4	OUTPUT SIGNAL, X AXIS
5	OUTPUT SIGNAL RTN, X AXIS
6	OUTPUT SIGNAL, Y AXIS
7	OUTPUT SIGNAL RTN, Y AXIS
8-13	N/C

## Performance Specifications

### STATIC/DYNAMIC

Input Range, g:	±0.25	±0.5	±1.0	±2.0	±5.0
Full Range Output (FRO -Note 1) VDC ±1%:	±5.00	±5.00	±5.00	±5.00	±5.00
Nonlinearity (Note 2) % FRO maximum:	0.02	0.02	0.02	0.05	0.10
Scale Factor, Volts/g, nominal:	20.0	10.0	5.0	2.5	1.0
Scale Factor Temp. Sensitivity (SFTS), PPM /°C maximum:	100	60	60	100	100
Bandwidth (-3 dB), Hz nominal:	30.0	30.0	30.0	30.0	30.0
Output Axis Misalignment, ° maximum:	0.50	1.00	1.00	1.00	1.00
Pendulous Axis Misalignment, ° maximum:	0.50	1.00	1.00	1.00	1.00
Bias, g range:	±0.001	±0.002	±0.004	±0.005	±0.005
Bias Temperature Sensitivity, Volts /°C maximum:	0.001	0.0005	0.0003	0.0003	0.0003
Resolution and Threshold, µg maximum:	1	1	1	1	1

### ELECTRICAL

Number of Axes:	2
Input Voltage Range, (VDC):	±12 to ±18
Input Current, mA, max:	50
Output Impedance, Ohms, nom:	100
Noise, Vrms, maximum:	0.002

### ENCLOSURE

Weight oz:	8
Seal:	MIL-STD-202, Method 112

### ENVIRONMENTAL

Operating Temp Range:	-40°C to +80°C
Storage Temp Range:	-60°C to +90°C
Vibration grms:	20
Shock:	1000 g, 1 msec, ½ sine

Notes: Note 1: Full Range is defined "from negative full input acceleration to positive full input acceleration."

Note 2: Nonlinearity is specified as deviation of output referenced to theoretical sine function value, independent of misalignment.

## How to Order

LCF-2530-.25g/.25g	468253-001
LCF-2530-.50g/.50g	468253-002
LCF-2530-1.0g/1.0g	468253-003
LCF-2530-2.0g/2.0g	468253-004
LCF-2530-5.0g/5.0g	Call for Part Number