

# Model MD908 "IRIS" Tilt Switch

The IRIS Tilt Switch and Controller powerful tilt control device with advanced firmware features. The on-board electrolytic tilt sensor is sensitive to <math><0.002^\circ</math>. User programmable settings include AUTO-zero (tare), sample averaging, hysteresis control, and more. Units support RS232 and RS422 (RS485 full duplex) output. The IRIS also supports a variety of output protocols including Trimble TCM, NMEA XDR, BAE, and Ashtech Compatible. Units ship standard with 24-in. hook-up cable. Use the IRIS for industrial pitch and roll measurement, platform leveling, specialized OEM assemblies, scientific instrument packages and more.

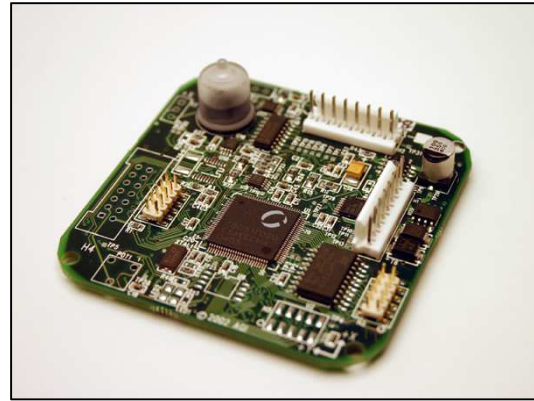

	High-Gain	Standard	Wide-Angle
Angular Range	$\pm 10^\circ$	$\pm 25^\circ$	$\pm 50^\circ$
Resolution	$0.002^\circ$	$0.004^\circ$	$0.01^\circ$
Repeatability	$0.01^\circ$	$0.01^\circ$	$0.02^\circ$
Non-Linearity	1%	1%	1%
Output	RS232, RS422 (RS485 full duplex)		
Output Format	NMEA XDR, Trimble TCM, Ashtec compatible, Simple (default: X, Y, Temp., S/N)		
Baud Rate	9600 (default), 19200, 28800, 57600, 115200, 130400		
Channels	X-tilt, Y-tilt, Temperature, Serial No.		
Tilt Switch Controls	8 TTL-compatible CMOS control outputs (0-5 VDC); 20mA source Power per channel (not to exceed 100mA across all 8 channels)		
Kz Coefficient (deg/C)	10 arcsec/ $^\circ$ C (typical)		
Ks Coefficient (%/C)	0.03%/ $^\circ$ C		
Time Constant	0.15 sec		
Natural Frequency	7 Hz		
Power	7-28 VDC @ 30mA, 250 mV ripple max, reverse polarity protected		
Environmental	$-40^\circ$ to $+85^\circ$ C operating and storage; 90% humidity non-condensing		
Dimensions	67 x 67 x 25 mm, 31g (1.1 oz)		
Materials	Glass electrolytic sensor, fiberglass PCB		

*Specifications subject to change without notice on account of continued product development*

### Ordering Code:

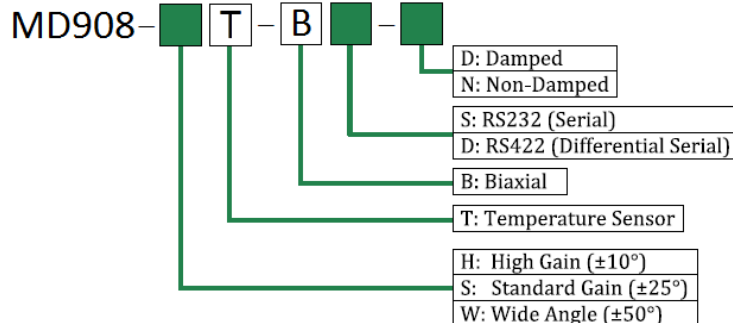

### Accessories:

P/N	Description
84063-01	Extra 24-in Cable Assembly, RS232 , H1 Header to DB9-sub Connector
84088-01	Extra 24-in Cable Assembly, RS422 , H1 Header to DB9-sub Connector
84083-01	24-in Tilt Switch Control Cable (Connects to H3 Terminal), Tinned Ends
00254-02	Transformer, 100-240VAC to 12VDC

# Model MD908 "IRIS" Tilt Switch

## A Full-Featured Inclinometer

The IRIS Tilt Switch and Controller is a versatile biaxial clinometer that measures rotational movement in two orthogonal vertical planes. Serial ASCII data are output as either RS232 or RS422(RS485 full duplex) signals for recording by an external terminal or computer. Important features are firmware-controlled and user-selectable. These include output data rates and formats, signal averaging, autozero (nulling), and internal data storage (logging). Several output data formats are provided, all of which include X tilt, Y tilt, Temperature and Serial Number information.

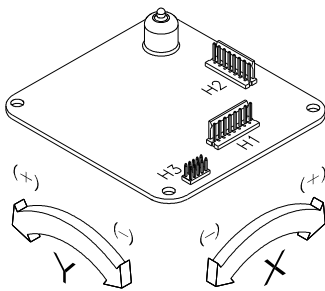

## A Powerful Control Device

The firmware on the standard IRIS board has 5 user programmable thresholds. When a tilt measurement is taken, it is compared to each of these thresholds: +X tilt, -X tilt, +Y tilt, -Y tilt and tilt in any direction. If the measurement exceeds one or more of the thresholds, the corresponding output pin(s) in the H3 connector, are set high (5V), as shown below. If the threshold is not exceeded, the output remains at 0 Volts. The reference angle for the threshold measurement is selected using the autozero command. Threshold checking may be turned off with a single firmware command when it is not needed.

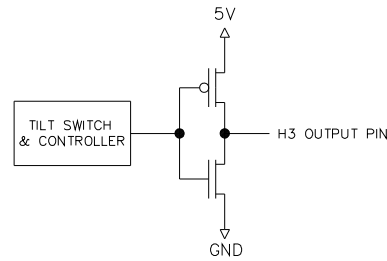

The standard IRIS firmware also allows the user to set the hysteresis of the control thresholds. The hysteresis is used as follows: After an H3 output pin is set high, it is not set low again until the tilt reading has reached a level that is below the threshold by an amount equal to the hysteresis (see diagram).

The IRIS includes 3 additional control output pins in the H3 connector, bringing the total to 8. These 3 additional pins are not active in the regular versions of the product, but may be implemented for your application by custom programming by our software engineers. Each of the 8 control outputs is separately programmable. Another custom option is "normally high" control output instead of the standard "normally low" output. With "normally high" controls the voltage level of the H3 pin is 5V until a threshold is reached, at which time it switches to 0V.

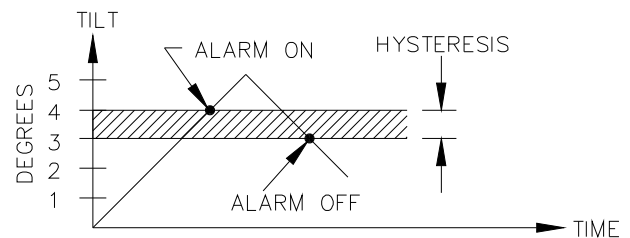

In standard IRIS models the control pins in connector H3 are all set high for approximately 150 milliseconds on power up, after which they reset to their "normally low" value of 0V until a tilt threshold is detected.

# Model MD908 "IRIS" Tilt Switch

## IRIS Tilt Switch & Controller Dimensions and Pin-outs

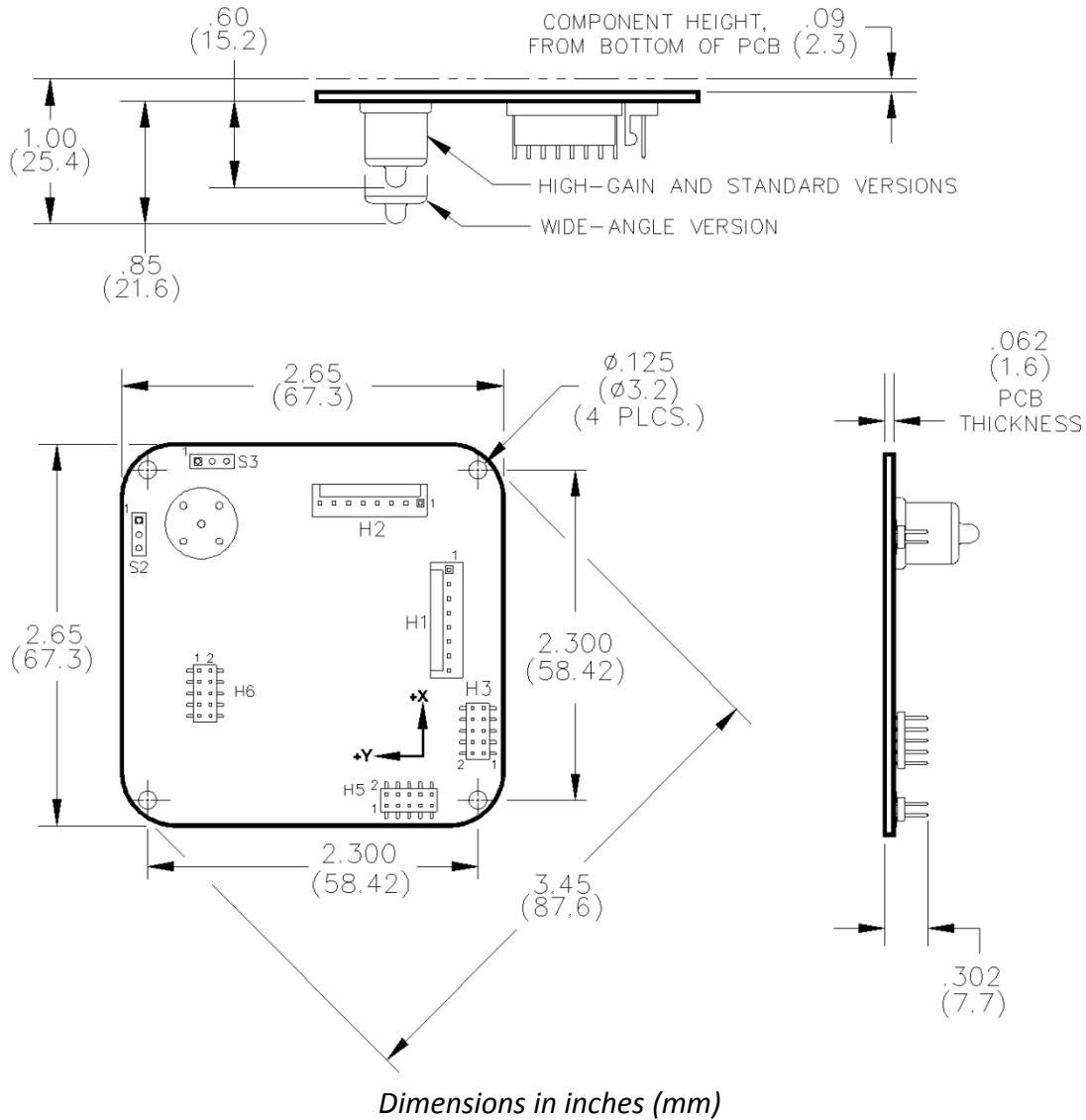

### Pin-outs:

H1 Pin	Function
1	V+
2	GND
3	Tx (RS232)
4	Rx (RS232)
5	Tx+ (RS422)
6	Tx- (RS422)
7	Rx- (RS422)
8	Rx+ (RS422)

H2 Pin	Function
1	V+
2	GND
3	GND
4	--
5	--
6	--
7	Analog X-out
8	Analog Y-out

H3 Pin	Function
1	-X tilt threshold
2	+X tilt threshold
3	-Y tilt threshold
4	+Y tilt threshold
5	Optional threshold*
6	Optional threshold*
7	Optional threshold*
8	Threshold in any direction
9	Ground
10	3.3 VDC output