

If your compass application involves vibration, acceleration, uneven terrain, or rough seas, you will find the Jewell Instruments ECG Series to be an uncompromising solution that will outperform rival units costing considerably more. The ECG provides remarkably accurate heading, pitch, and roll in dynamic conditions. It all starts with a precision 3-axis solid-state magnetometer. Two angular rate gyros independently stabilize pitch and roll. They augment a dual-axis, electrolytic tilt sensor that provides precise tilt measurements in static environments. Two sets of independent filters, one set for pitch and one for roll, combine gyro and electrolytic sensor measurements to provide the best available tilt measurements.

The recommended applications for the ECG are manned and unmanned vehicles, robotics, weather buoys, antenna positioning, platform stabilization, marine navigation, excavation machinery, and irrigation equipment.

The exceptional performance of the ECG is achieved by first calibrating all sensors over a wide temperature range. Then Jewell Instruments aligns the magnetic, tilt, and rate sensors to a common set of axes using precision calibration equipment capable of measuring angles as small as 0.001°. This alignment procedure, driven by our proprietary calibration routines,

minimizes axis coupling and corrects for gyro drift errors.

The ECG is compatible with Jewell's ECS and ECX series. The ECG board fits in the same enclosure and has the same mounting hole pattern and connectors. Identical NMEA sentences are available, and the ECG version includes additional binary data output for temperature and diagnostics.

The ECG comes with an enhanced version of Jewell's demonstration software that is backward compatible with the ECS and ECX. The magnetic calibration procedure required upon installation is identical, as are cabling and power requirements.

For more information, pricing, and availability, please call Jewell Instruments or e-mail sensors@jewellinstruments.com.



Features

- ◆ **Exceptional Dynamic Performance**
 - ⇒ Heading within 3° typical for rates < 250 °/sec
 - ⇒ Pitch and roll within 0.3° for rates < 250 °/sec
- ◆ **High Static Accuracy**
 - ⇒ Heading within 0.5° or better
 - ⇒ Tilt within 0.2° or better
- ◆ **Wide Operating Range**
 - ⇒ ±42° Pitch and Roll
 - ⇒ ±80° Dip angle range
 - ⇒ Temperature -40° to 105°C
 - ⇒ Local Hard Iron to ±1.5 Gauss
- ◆ **Precise Calibration**
 - ⇒ Gyros calibrated for offset and gain from -40° to 85°C
 - ⇒ Rate sensors calibrated and aligned to magnetometer and tilt sensor
 - ⇒ Cross-axis error nearly eliminated on gyros and magnetometer
- ◆ **Single Supply Operation**
 - ⇒ 6 to 45V unregulated DC or
 - ⇒ 5V regulated DC
 - ⇒ Thermal overload and reverse polarity protection
- ◆ **Fast Response**
 - ⇒ 28 readings per second
 - ⇒ Wake from standby in 50 msec
- ◆ **Low Power**
 - ⇒ 30 mA operating
 - ⇒ 10 mA sample
 - ⇒ 5 mA standby
- ◆ **Wide Selection of ASCII or Binary Output data**
 - ⇒ Heading, pitch, and roll
 - ⇒ Magnetometer X, Y, and Z
 - ⇒ Temperature, input voltage, and dip angle
 - ⇒ Output ASCII or binary
 - ⇒ Horizontal X and Y magnetic field strength
 - ⇒ Raw and conditioned gyro data
- ◆ **Two independent serial channels**
 - ⇒ Full-duplex RS-232 for the external RJ12
 - ⇒ Either RS-232 or full-duplex RS-485 for the internal connector
- ◆ **In-System Configuration and Test**
 - ⇒ Laptop can be connected while unit operates in situ
 - ⇒ Perform hard and soft iron calibration
 - ⇒ Monitor outputs and change user-definable settings

Specifications

Heading Performance

| Parameter | Value | Conditions |
|-----------------------|---------------|------------------------------|
| Accuracy ¹ | ± 0.5° rms | Static, Tilt < 35° Dip < 60° |
| | ± 3.0° rms | Dynamic, rate < 250°/sec |
| Repeatability | ± 0.3° | Static, no filter |
| Response time | 36 msec | Minimum, no filter |
| Dip Angle Range | ± 80° | |
| Tilt Range | ± 40° | |
| Update rate | 28 per second | |

¹ May require calibration after installation to eliminate effect of local magnetic field

Pitch and Roll Performance

| Parameter | Value | Conditions |
|---------------|---------|--------------------|
| Accuracy | ± 0.3° | Factory calibrated |
| Repeatability | ± 0.2° | No filter |
| Range | ± 42° | |
| Settling time | 0.5 sec | Gyros enabled |

Electrical

| Parameter | Value | Conditions |
|-----------------------------------|--|-------------|
| Supply Current | <i>Below values are the same color</i> | |
| | 30 mA operating | typical |
| | 10 mA sample | typical |
| | 2 mA standby | typical |
| Supply Voltage (V _{DD}) | <i>Below values are the same color</i> | |
| | 6 – 45 Vdc unregulated | 4.9 Vdc min |
| | 5.0 Vdc regulated | |

Environmental

| Parameter | Value |
|---------------------|---------------|
| Operating Temp | -40° to 105°C |
| Storage Temperature | -50° to 150°C |
| Humidity | 0 to 90% |

Mechanical

| | |
|--------------------|---|
| Enclosure Material | Plastic Enclosure (P Option): (ABS) Flame Retardant UL94 VO Aluminum Enclosure (A Option): Diecast Aluminum Alloy (Type 360.1) |
| PCB Size | 1.8"W x 3.0"L x 0.6"H |
| PCB Mounting | 4 #4 screws, 1.4" x 2.2" spacing |
| Weight | Plastic Enclosure (P Option): 3.2 oz. (90.7 grams) Aluminum Enclosure (A Option): 7.2 oz. (204.1 grams) |
| Connectors | 8 pin, single-row, 0.1" friction header 6 pin RJ12 modular jack |

Interface

| | |
|--------------------|--|
| Signal type | RS-232 and RS-485 |
| Baud rate | 2400, 4800, 9600, 19200, 38400, or 57600 bps |
| Character Format | 8 data, no parity, 1 stop |
| Input Buffer Size | 110 characters |
| Output Buffer Size | 110 characters |
| Output Format | NMEA 0183 and binary |
| Output Data Rate | 1 to 1650 sentences per minute |
| Operating Modes | Continuous or sample |
| Angle Units | Degrees, mils, radians, 16-bit integer |

*Specifications subject to change without notice on account of continued product development

How to Order

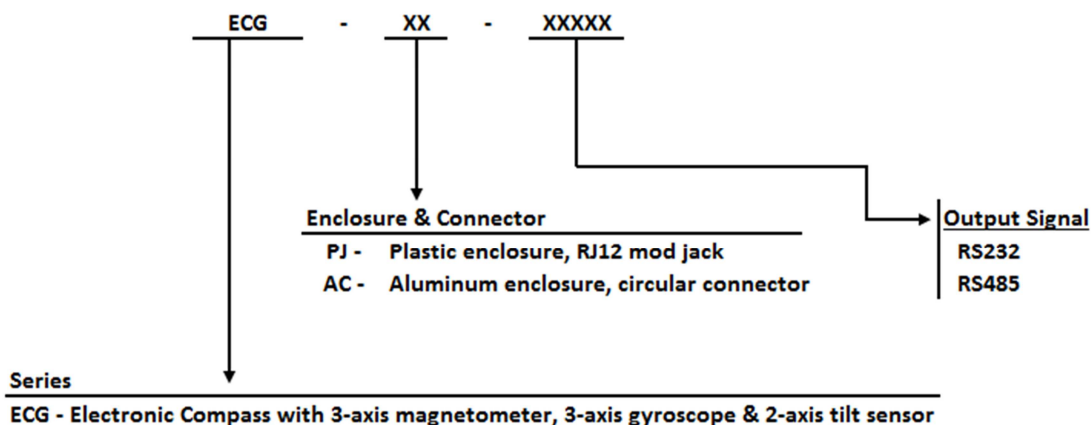

Example:

ECG-PJ-RS232

ECG Electronic Compass with 3-axis magnetometer, 3-axis gyroscope & 2-axis tilt sensor plastic enclosure, RJ12 mod jack & RS232 output signal

Dimensions of Aluminum Enclosure

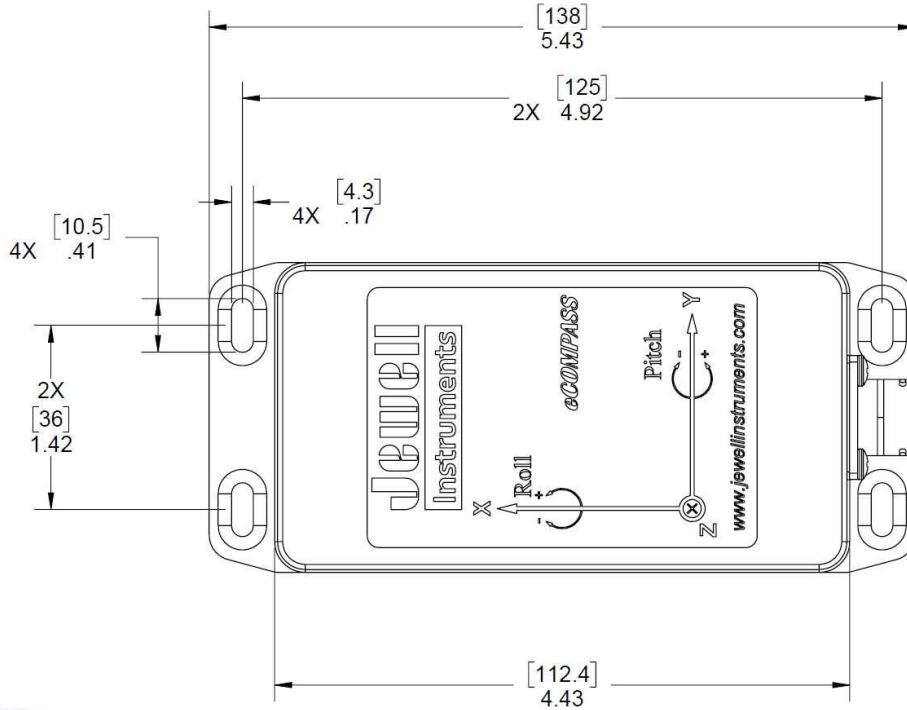

MS3470A10-6S

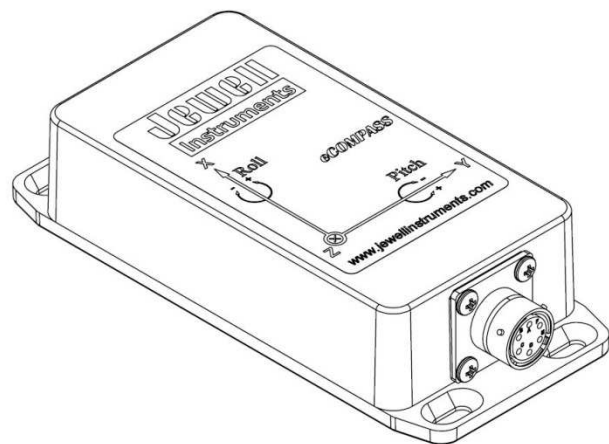
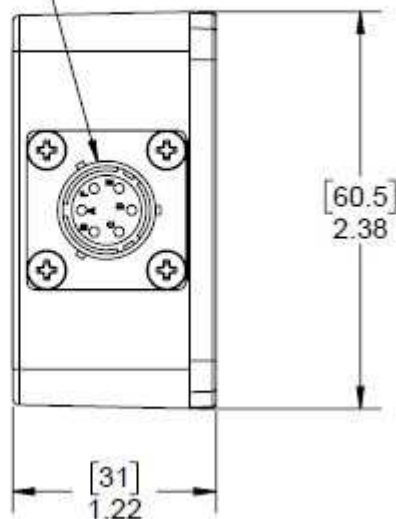

Dimensions: mm [in]

Dimensions of Plastic Enclosure

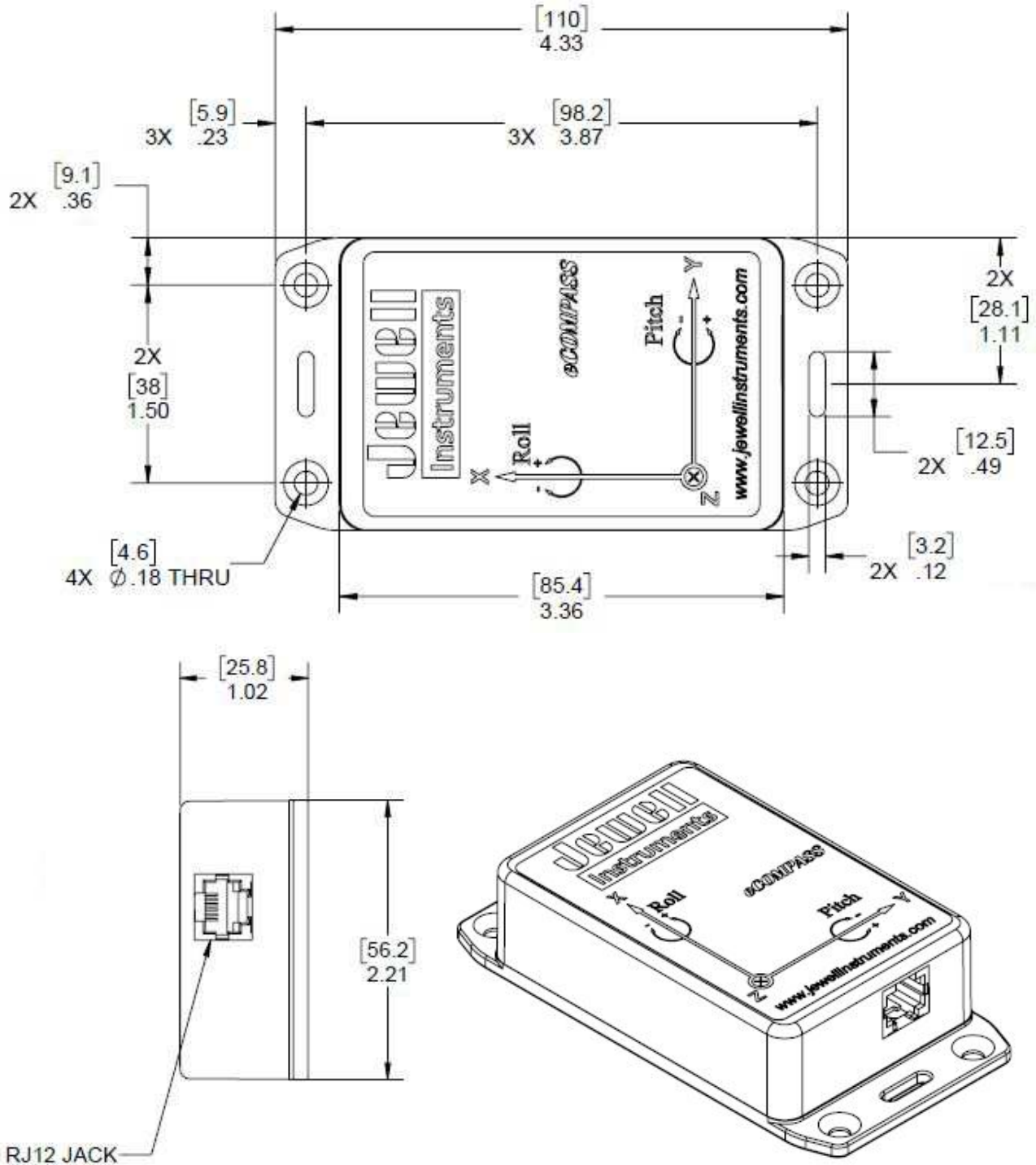

Dimensions: in [mm]

Pin Outs

| J1 RJ-12 Jack Pin Out | |
|-----------------------|--------|
| Pin 1 | Ground |
| Pin 2 | Power |
| Pin 3 | TX |
| Pin 4 | RX |
| Pin 5 | Ground |
| Pin 6 | 100K |

| J2 8-Pin Header Pin Out | |
|-------------------------|--------------|
| Pin 1 | Power |
| Pin 2 | RS232 TX Out |
| Pin 3 | RS232 RX In |
| Pin 4 | RS485 RX+ |
| Pin 5 | RS485 RX- |
| Pin 6 | Ground |
| Pin 7 | RS485 TX+ |
| Pin 8 | RS485 TX- |

Interface Block Diagram

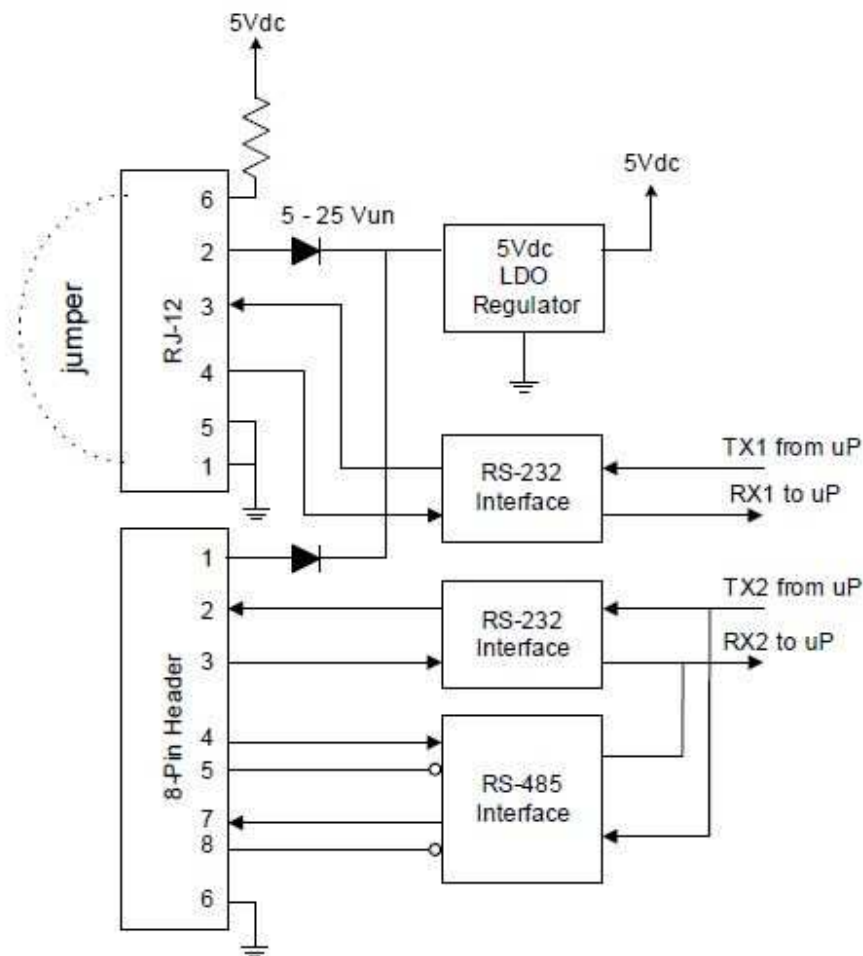

Wiring Drawings

RS-232

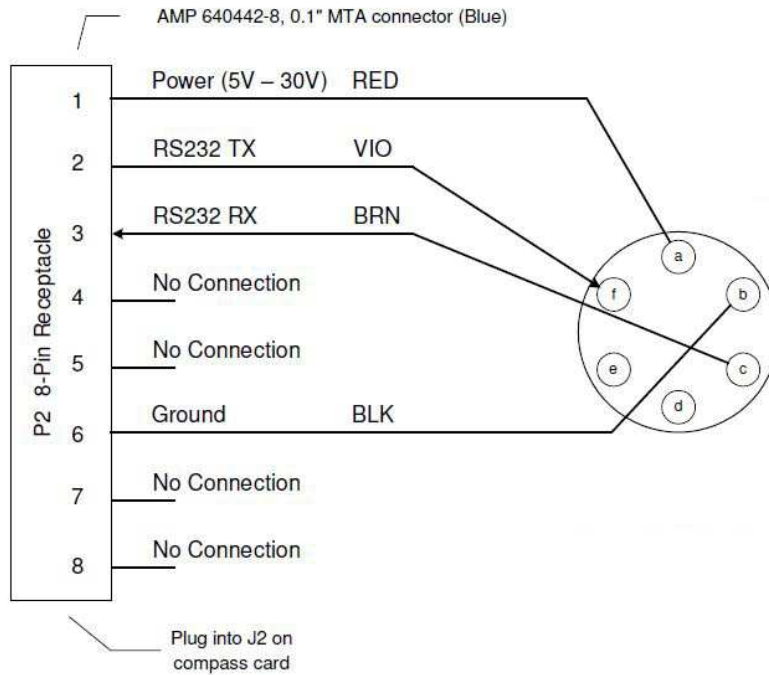

RS-485

