



STANDARDS

- Valve design: ASME B16.34
- Material certification: EN10204-3.1 MTR
- End connections: ASME B16.11, ASME B1.20.1, ASME B16.25
- Steel casting: MSS SP-55
- Valve marking: MSS SP-25
- Direct mount: ISO 5211
- Face to face: ASME B16.10
- Class / Pressure Rating: Class 600
- Sulfide stress cracking: NACE MR-01-75
- CRN Number available; UL certified

J Flow Controls DM4600 Series Three Piece Direct Mount Ball Valves

FEATURES & BENEFITS

- Body and end caps quality investment casting
- With ISO 5211 mounting pad
- With locking function
- Adjustable Stem Packing
- Standard in Stainless Steel or Carbon Steel
- Blow-out proof stem design
- 100% air tested under water at 100 psi
- Working pressure of 2160 psi
- Temperature range of -320°F to 800°F
- End type: butt weld, flanged, socket weld and threaded
- MTR report available

OPTIONS

- Spring return (dead-man) handle
- Extended stem for isolation
- V-Ball for control valve in 15°, 30°, 45°, 60°, 90°, slot or custom
- Automation applicable
- Fugitive emissions bonnet
- PTFE / PFA coating (40-70 um)
- Alloy 20 / Monel / Hastelloy C276 / Titanium / Duplex 2507
- Cryogenic valve to -325°F

BILL OF MATERIALS

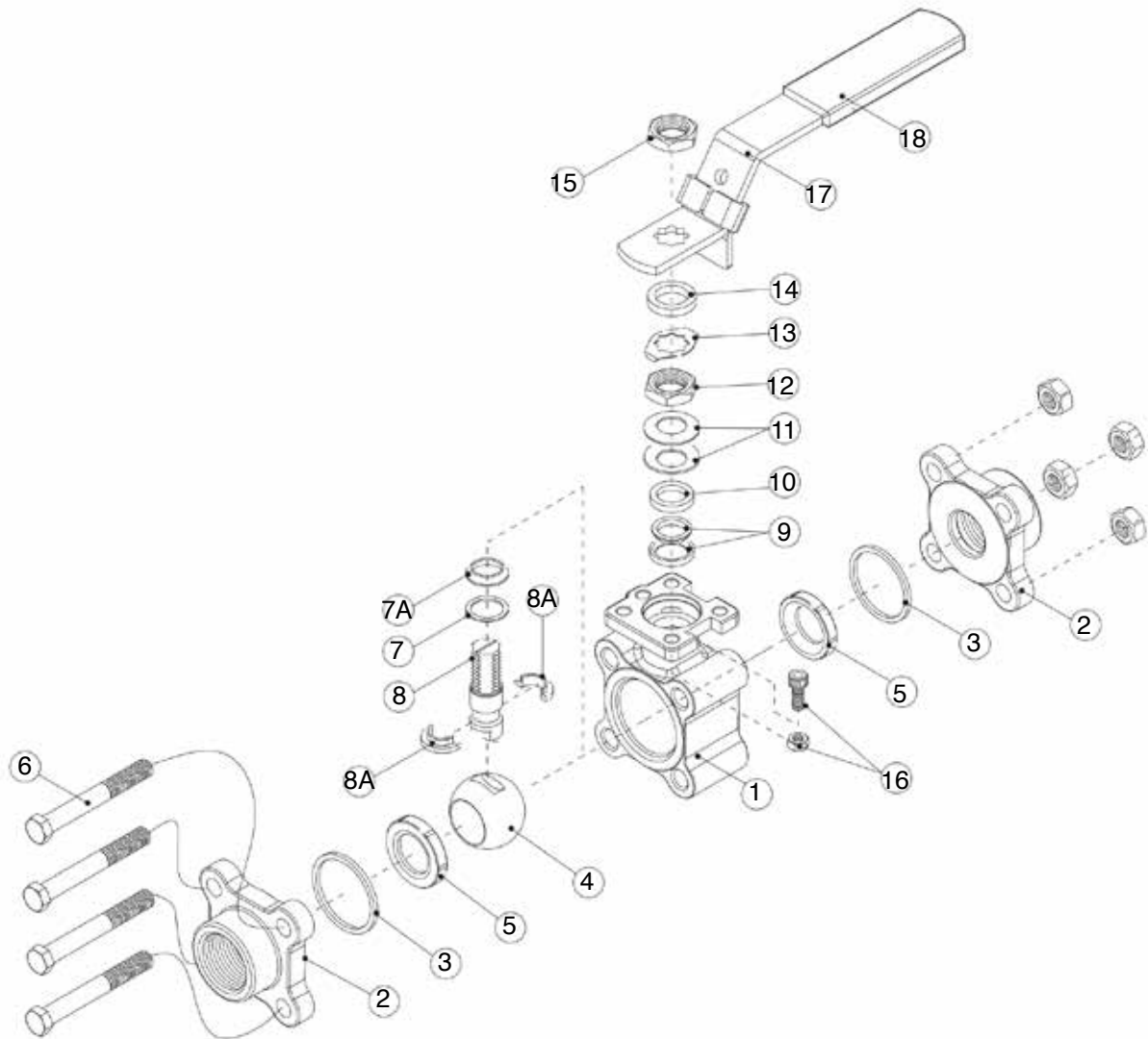

No	Part Name	Materials	No	Part Name	Materials
1	Body	CF8M/WCB	9	Stem Packing	TFM
2	End Cap	CF8M/WCB	10	Gland Washer	SS304
3	Gasket (Body)	TFM	11	Disk Washer	SS301
4	Ball	SS316	12	Stem Nut	SS304
5	Ball Seats	TFM / TCC / PEEK	13	Nut Stop	SS304
6	Bolts	SS304	14	Space Washer	SS304
7	Thrust Washer	TFM	15	Handle Nut	SS304
7A	Thrust Washer	PEEK	16	Stop Pin	SS304
8	Stem	SS316	17	Handle	SS304
8A	Half Split Ring	SS316	18	Handle Cover	Plastic

DM4600 Series Ball Valves

DIMENSIONS

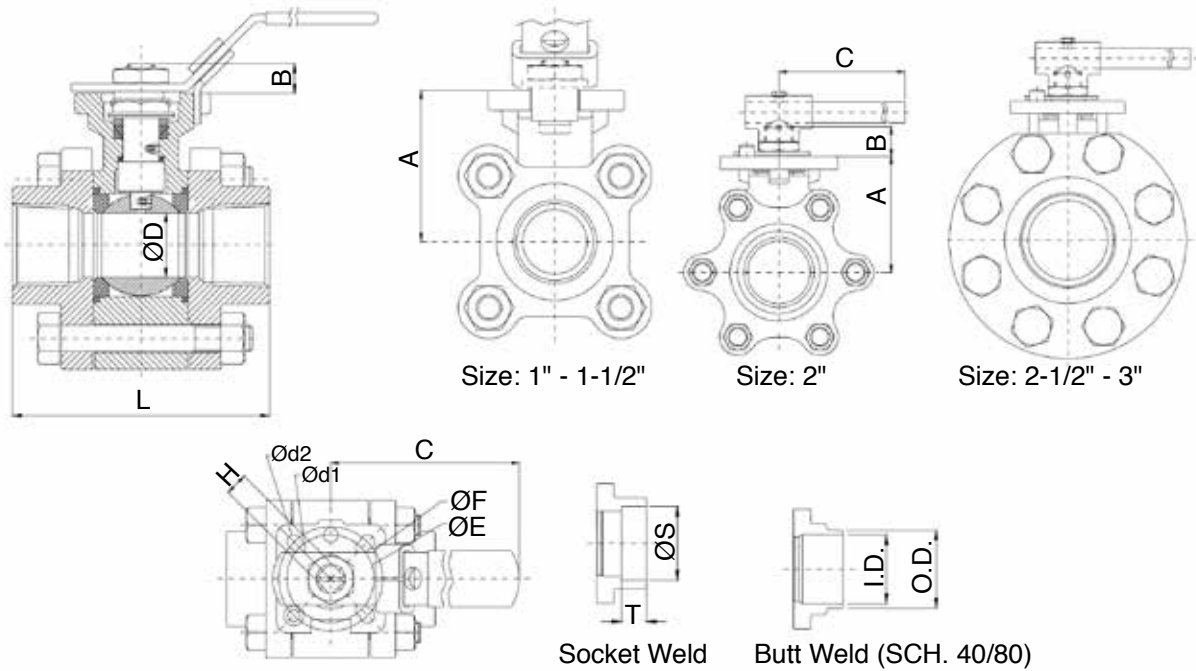

Size	A	B	C	D	d1	d2	E	F	H	L
1/4"	1.81	0.37	5.12	0.43	0.24	0.24	1.42	1.65	0.35	2.62
3/8"	1.81	0.37	5.12	0.49	0.24	0.24	1.42	1.65	0.35	2.62
1/2"	1.89	0.37	5.12	0.59	0.24	0.24	1.42	1.65	0.35	2.76
3/4"	2.09	0.47	6.10	0.79	0.24	0.24	1.65	1.97	0.43	3.62
1"	2.32	0.47	6.10	0.98	0.24	0.28	1.65	1.97	0.43	4.13
1-1/4"	2.44	0.57	8.07	1.26	0.28	0.36	1.97	2.76	0.55	4.37
1-1/2"	2.76	0.57	8.07	1.50	0.28	0.36	1.97	2.76	0.55	4.88
2"	3.54	0.75	12.60	1.97	0.36	0.45	2.76	4.02	0.67	5.91
2-1/2"	4.13	0.71	13.78	2.50	0.36	0.45	2.76	4.02	0.67	6.50
3"	4.69	0.98	20.47	3.07	0.45	0.53	4.02	4.92	0.67	7.68

Size	SW		BW (40#)		BW (80#, std)	
	S	T	OD	ID	OD	ID
1/4"	0.56	0.44	0.55	0.36	0.55	0.30
3/8"	0.69	0.44	0.67	0.50	0.67	0.43
1/2"	0.86	0.50	0.84	0.63	0.84	0.54
3/4"	1.07	0.56	1.05	0.81	1.05	0.74
1"	1.33	0.63	1.31	1.05	1.31	0.96
1-1/4"	1.67	0.69	1.66	1.38	1.66	1.28
1-1/2"	1.92	0.72	1.92	1.59	1.92	1.50
2"	2.41	0.84	2.41	2.06	2.41	1.94
2-1/2"	2.91	0.87	2.91	2.47	2.91	2.32
3"	3.54	1.00	3.54	3.07	3.54	2.90

DM4600 Series Ball Valves

BREAK-TORQUE VALUE (IN-LB AT 0 PSI)

Size	1/4"	3/8"	1/2"	3/4"	1"	1-1/4"	1-1/2"	2"	2-1/2"	3"
Seat	TFM	TFM	TFM	TFM	TFM	TFM	TFM	TFM	DELRIN	DELRIN
Grease	71	71	106	133	159	221	416	735	1460	2213

Note 1: The greases J Flow Controls uses include lubricants and anti-seize that are both SILICONE-FREE

Note 2: J Flow Controls strongly suggests increasing the torque at least 30% - 40% for safety factor when mounting an actuator

FLOW COEFFICIENT (FULL PORT VALVE)

Size	Cv Factor
1/4"	8.5
3/8"	8.5
1/2"	21
3/4"	50
1"	90
1-1/4"	110
1-1/2"	240
2"	400
2-1/2"	700
3"	980

PRESSURE/TEMPERATURE CHART

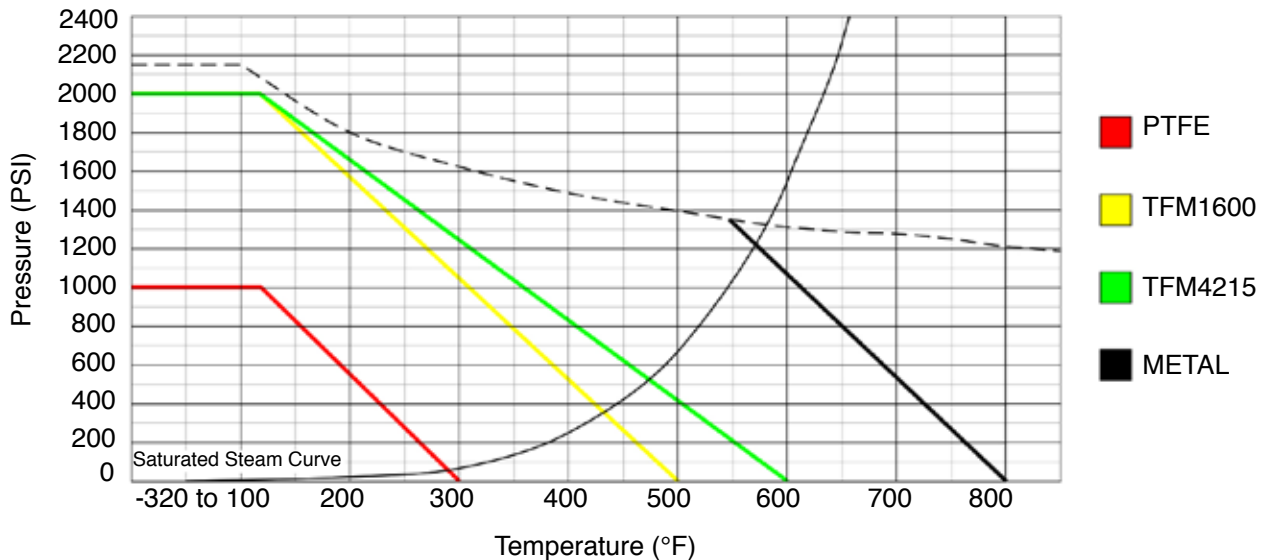

DM4600 Series Ball Valves

HOW TO ORDER

Sizes		Series	Body ¹ , Ball & Stem		Port		Body Seal	
1	1/4"	46	00	CF8	F	Full Port	T	TFM1600
2	3/8"		0L	CF3	1	15° V-Ball	C	TFM4215
3	1/2"		23	WCB, CF8M Ball & Stem	3	30° V-Ball	G	Graphite
4	3/4"		33	CF8M	6	60° V-Ball		
5	1"		44	Alloy 20	9	90° V-Ball		
0	1-1/4"		55	Monel				
6	1-1/2"		6L	CF3M				
7	2"		77	Hastelloy C				
8	2-1/2"		88	LCB				
9	3"	83	LCB, CF8M Ball & Stem					
		99	Duplex					

Packing		Seat	End Connections		Options		
T	TFM1600	T	TFM1600	F1	ANSI 150 RF Flange	CF	Cavity-Filled Seats
C	TFM4215	C	TFM4215	F3	ANSI 300 RF Flange	LD	Locking Handle
G	Graphite	M	CF8M	SW	Socket Weld	SH	Spring Handle
				PT	Female NPT	GO	Gear Operator
				B1	Butt Weld Sch 10	BS	Bare Stem
				B4	Butt Weld Sch 40	FE	Fugitive Emission
				B8	Butt Weld Sch 80	FS	Fire Safe
				E1	Extended Butt Weld Sch 10	SE	Stem Extension
				E4	Extended Butt Weld Sch 40	VB	Vented Ball
				E8	Extended Butt Weld Sch 80		
				E6	Extended Butt Weld Sch 160		
				TW	Female NPT X Socket Weld		
				ES	Extended Socket Weld		

¹ Please see the J Flow Controls Configurator for a full list of body materials



4665 Interstate Drive
Cincinnati, OH 45246
513-731-2900
jflowcontrols.com

While the information and specifications contained in this literature are believed to be accurate, they are supplied for informative purposes only and should not be considered certified or a guarantee of satisfactory results. Nothing contained herein is to be construed as a warranty or guarantee, express or implied, regarding any matter with respect to this product. Because J Flow Controls® is continually improving and upgrading its product design, the specifications, dimensions and information contained herein are subject to change without notice.