

V550 VERIS Verabar[®] **(Flanged Spring-Lock)** **Installation and Maintenance Manual**



**Please read and save
these instructions**

Contents

General Safety Information	3
Product Information	3
Section 1: Scope	3
Purpose of this Manual	3
Section 2: Receiving and Inspecting	
Receiving and Inspecting the Verabar®	3
Section 3: Safety Precautions	3
 Safety Messages and Application Requirements	3
Section 4: Installation Preparations	3-5
Location	3
Orientation	4
Horizontal Piping	4
Vertical Piping	5
DP Transmitter/Local Indicator Location	5
Installation Drawings and Bill of Materials	5
Section 5: Installation Procedure	5-9
Preparing the Pipe	5
Weld Mounting Flange to Pipe	6-7
Insert Sensor	7-8
Insert Instrument Vales or Manifold	9
Valves	9
Manifold	9
Pressurize Pipe and Retighten Bolts	9
Section 6: Periodic Maintenance	10
Limited Warranty and Remedy	11

General Safety Information

Instructions and procedures listed in this manual may require special precautions to ensure the safety of the individuals performing the operations. **Review the entire manual, taking note of safety messages prior to performing any operations listed in the manual.**

Product Information

The VERIS Verabar® averaging pitot flow sensor provides unsurpassed accuracy and reliability. With its solid, one-piece construction and bullet shape the VERIS Verabar® makes flow measurement reliable and precise.

The unique sensor shape reduces drag and flow induced vibration. The location of the low-pressure ports eliminates the potential for clogging and improves signal stability.

The V550 model features flanged mounting components and a spring-lock feature that locks and pre-loads the sensor to the opposite pipe wall regardless of changes in pipe ID due to pressure, temperature, or mechanical force.

Section 1 Scope

These instructions provide a description of procedures for installing the V550 Verabar® model flow sensor. Procedures are given for all industrial flow measurement applications including liquid, steam and gas, for both horizontal and vertical piping configurations.

Section 2 Receiving and Inspection

The following tasks should be performed as part of the receiving inspection procedure:

- Check items received against the packing list.
- Check sensor nameplate for proper model number, serial number and tag number.
- Verify the actual pipe diameter matches the ID stated on the sensor nameplate.
- Check the bullet shaped sensor tube for any signs of damage. Damage to the sensor tube may result in erroneous flow readings.
- Check the round cover tube for any damage, especially axial gouges or scratches. Damage to the cover tube may prevent the packing from sealing properly.

Section 3 Safety Precautions

The following process should be conducted prior to installing the Verabar® flow sensor:

- Check the maximum operating conditions on the flow sensor nameplate. Verify that the maximum operating conditions of the application do not exceed the parameters stated on the nameplate. If any pressure, temperature, or flow limits will be exceeded, contact the factory before proceeding.
- Check to ensure the pipe is depressurized and drained prior to installation.
- Be cautious of pipe temperature prior to prepping the pipe for installation.
- The Spring-Lock Model V550 is designed for carbon and stainless steel pipes with a schedule 10 or heavier wall thickness. The V550 should not be used with PVC, copper, aluminum, cast iron or thin-walled pipes or ducts. If there is any question as to the proper application for a model V550, consult the factory.

Section 4 Installation Preparations

4.1 Location

For the most accurate flow measurement, a minimum straight run of pipe is required. Table 1 shows the minimum straight run requirements.

If longer straight runs are available, position the Verabar® such that the ratio of upstream straight run to downstream straight run is approximately 4 to 1. If straight run lengths are less than the values stated in Table 1, consult the factory for additional accuracy and location information.

Straightening vanes should be positioned such that the end closest to the Verabar® is half way between the Verabar® and the closest upstream configuration. For elbow installations, mount the Verabar® in the same plane as the closest upstream elbow.

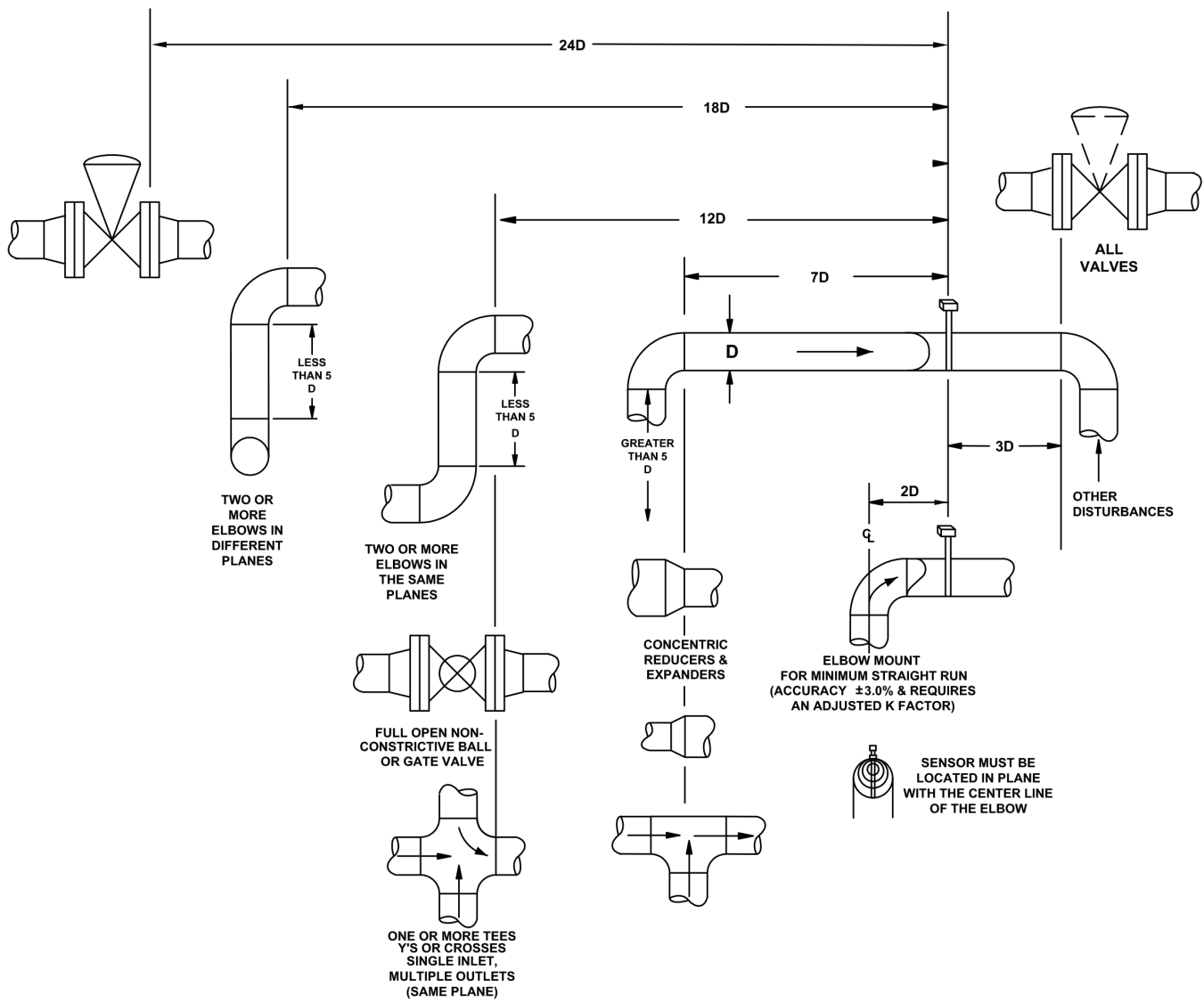

Table 1. Straight Run Requirements

4.2 Orientation

Verify the proper sensor orientation by checking for an “-H” (horizontal piping) or a “-V” (vertical piping) in the model number on the Verabar® sensor nameplate.

Deviation from the following mounting location instructions may cause inaccuracy in the flow measurement.

4.2.1 Horizontal Piping

For air or gas installations, mount the Verabar® in the upper 160° of the pipe to allow any condensate to drain into the pipe (Figure 1). For liquid or steam installations, mount the Verabar® in the lower 160° of the pipe. This allows any entrained air to bleed back into the pipe for liquid applications and allows condensate to collect in the instrument piping for steam applications.

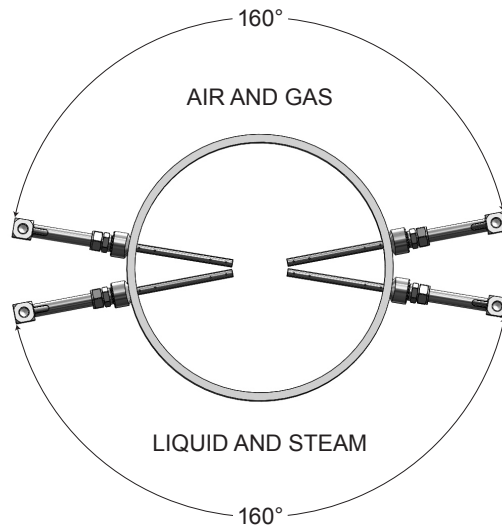

Figure 1. Verabar® Orientation in Horizontal Pipe

4.2.2 Vertical Piping

The Verabar® may be mounted in any location around the circumference of the pipe for vertical piping applications.

4.3 DP Transmitter/Local Indicator Location

When choosing a Verabar® location, consider the DP transmitter/local indicator location:

- The transmitter must be mounted below the Verabar® for liquid and steam applications.
- The transmitter must be mounted above the Verabar® for air and gas applications.

4.4 Installation Drawings and Bill of Materials

Additional information is available in the Installation Drawings and Bill of Materials VB-7061 (Contact factory for access information). It contains standard and alternate transmitter locations and a complete bill of materials based on the fluid type and sensor orientation on the pipe.

Section 5 Installation Procedure

5.1 Preparing the Pipe

- Completely depressurize and drain pipe prior to installation of the Verabar®.
- Mark the location of the hole through which the Verabar® will be mounted. Use a center punch to mark the hole to prevent the drill bit from walking on the pipe.
- Drill the pipe with the proper sized hole per the following table (Important: Do not torch cut hole!):

Sensor Size	Hole Diameter
V550-05	½" (13mm)
V550-10	1" (25mm)
V550-15	1-1/2" (38mm)

• IMPORTANT:

Deburr the hole on the inside of the pipe.

5.2 Weld Mounting Flange to Pipe

- With the follower and packing rings already in place (factory assembled), insert the sensor into the Spring-Lock body (Figure 3). Loosely bolt together (hand tight) the sensor, gasket and mounting flange. Insert the assembly until the tip of the sensor hits the opposite side of the pipe. Align the head of the sensor so that the arrow labeled “FLOW” on the head is in the direction of the flow to within 3°. The contour of the weld coupling should match the contour of the pipe. Check that the bottom of the weld coupling is in contact with the pipe wall.

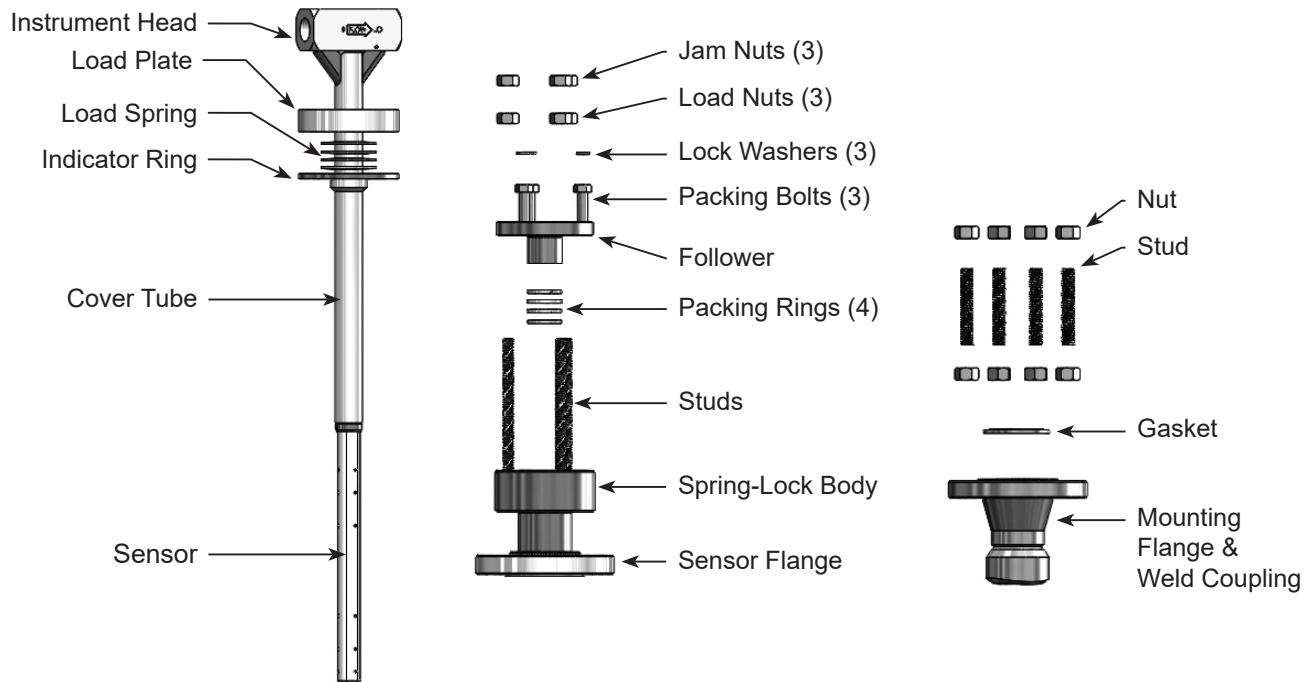

Figure 2. Verabar® Model V550 Assembly

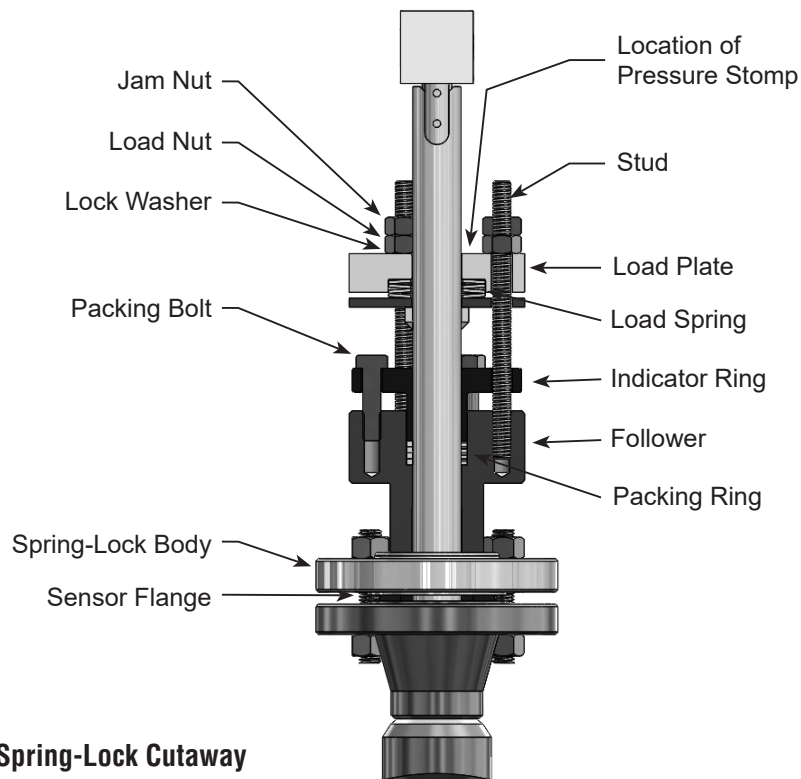

Figure 3. Spring-Lock Cutaway

- Using the appropriate weld gap (1/16" [1.5mm] typical), tack weld the mounting flange into position (see Figure 4).

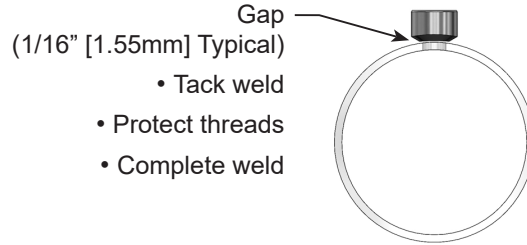

Figure 4. Weld Gap

- Note the flange orientation per Figure 5. The bolt holes on the flange should straddle the centerline of the pipe (2-holing pattern).

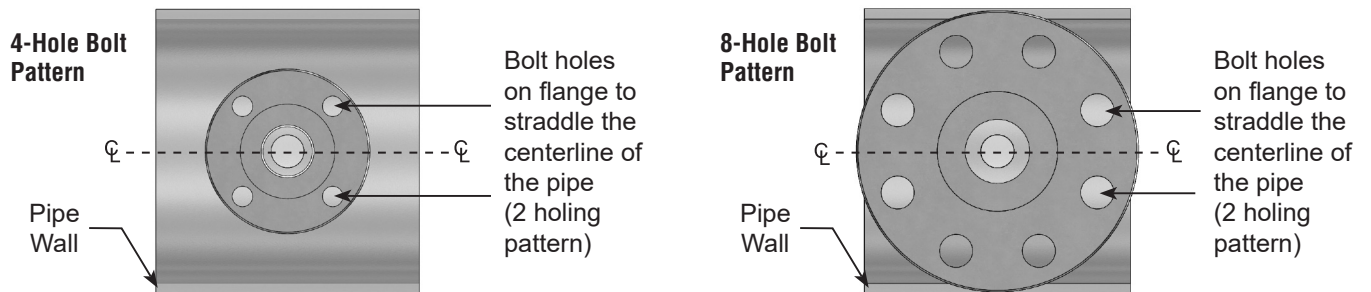

Figure 5. Flange Orientation

- Remove the sensor and sensor flange, and finish welding the weld coupling to the pipe per applicable piping codes.

5.3 Insert Sensor

- With the follower and packing rings already in place (factory assembled), insert the sensor into the Spring-Lock body. Bolt the sensor flange to the mounting flange with the gasket between the flanges. The nuts should be tightened until the gasket is completely crushed (the gasket thickness should be approximately 1/8" [3mm]). Insert the assembly until the tip of the sensor hits the opposite side of the pipe. Note the three studs must pass through the indicator ring and the load plate.
- Align the head of the sensor so that the arrow labeled "FLOW" on the head is in the direction of the flow in the pipe to within 3° (Figure 7). Maintain the head in this position for the remainder of the installation.
- Place the three lock washers and the three load nuts on the studs and tighten. Tighten the load nuts until the load plate is 0.050" (1.3mm) from the indicator ring for -05 and -10 sensors. For -15 sensors, the load plate should be 0.063" (1.6mm) from the indicator ring (Figure 6). For -05 sensors, this can be done by tightening all the load nuts until the load plate just touches the indicator ring and then backing off all the load nuts one complete turn. For -10 and -15 sensors, this can be done by tightening all the load nuts until the load plate just touches the indicator ring and then backing off all the load nuts 3/4 of a turn. The load springs are now properly set.
- Thread on the three jam nuts and tighten until they are resting hand-tight against the lock nuts. Place a backup wrench on the load nut to prevent it from rotating. While not allowing the load nut to rotate, tighten the jam nuts 1/8 turn beyond hand tight.
- Using a torque wrench, tighten the three packing bolts to the appropriate torque value listed in the table below.

Sensor Size	Packing Bolt Torque
-05	4.2 ft-lbs (5.7 Nm)
-10	8.3 ft-lbs (11.3 Nm)
-15	14.1 ft-lbs (19.1 Nm)

- Note: The weld on the weld ring (Figure 6) should not contact the top surface of the follower. If the weld on the weld ring comes into contact with the follower, the sensor will not be properly bottomed in the pipe. If this occurs, consult the factory before proceeding.

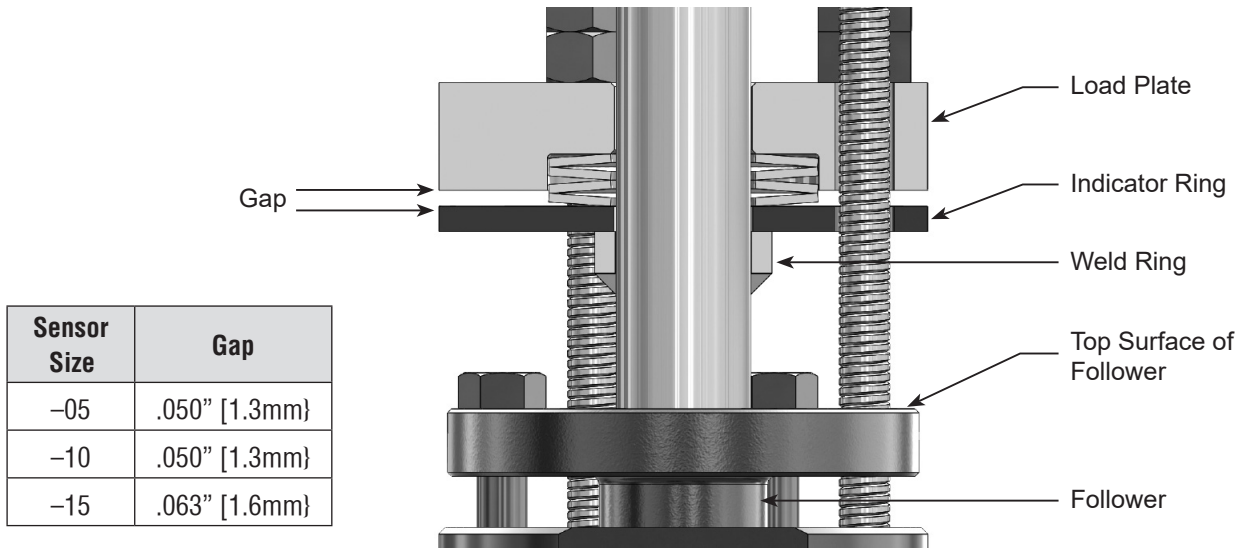

Figure 6. Proper Spring Compression

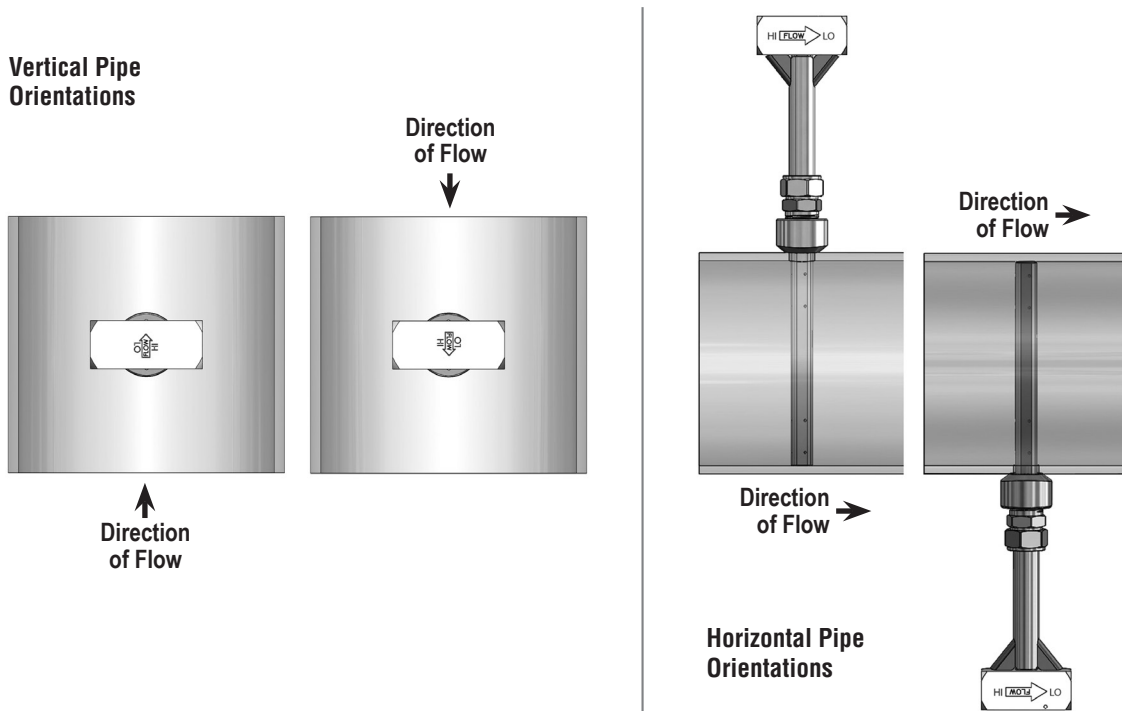

Figure 7. Orientation of Flow Arrow

5.4 Insert Instrument Vales or Manifold

5.4.1 Valves

- If the Verabar® does not have a valve head, install instrument valves using proper thread sealant. Be sure instrument shut-off valves are installed and shut prior to re-pressurizing the pipe.

5.4.2 Manifold

- If the Verabar® has a direct or integral manifold, be sure the high and low pressure block valves are shut off prior to re-pressurizing the pipe.

5.5 Pressurize Pipe and Retighten Bolts

- Pressurize the pipe and check for leaks. If leaks are present, retighten the packing bolts until leaking is eliminated. Verify that the distance between the load plate and the indicator ring is approximately 0.050" (1.3mm) for -05, and -10 sensors and 0.063" (1.6mm) for -15 sensors; make adjustments as required.

The Verabar® is now properly installed (Figure 8).

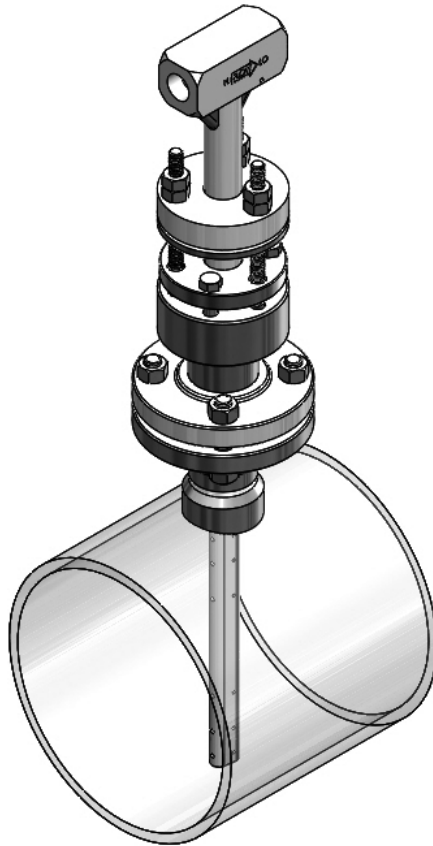

Figure 8. Installed V550

Section 6 Periodic Maintenance

The assembly should be periodically checked. Verify that no leaks are present. Tighten the packing bolts if necessary. Inspect sensor for wear or damage.

Note: Different threads require different maintenance requirements.

VERIS, Inc.

Limited Warranty and Remedy

VERIS, Inc. (“VERIS”) warrants to the original user of those products supplied by it and used in the service and in the manner for which they are intended shall be free from defects in material and workmanship for a period of five (5) years from the date of installation, but not longer than 63 months from the date of shipment from the VERIS factory, unless a Special Warranty Period applies, as noted below. This warranty does not extend to any product that has been subject to misuse, neglect or alteration after shipment from the VERIS factory. Except as may be expressly provided in a written agreement between VERIS and the user, which is signed by both parties, VERIS **DOES NOT MAKE ANY OTHER REPRESENTATIONS OR WARRANTIES, EXPRESS OR IMPLIED, INCLUDING, BUT NOT LIMITED TO, ANY IMPLIED WARRANTY OF MERCHANTABILITY OR ANY IMPLIED WARRANTY OF FITNESS FOR A PARTICULAR PURPOSE.**

The sole and exclusive remedy with respect to the above limited warranty or with respect to any other claim relating to the products or to defects or any condition or use of the products supplied by VERIS, however caused, and whether such claim is based upon warranty, contract, negligence, strict liability, or any other basis or theory, is limited to VERIS’ repair or replacement of the part or product, or, at VERIS’ option, to repayment of the purchase price. In addition to replacing any part of parts found to VERIS’ satisfaction to be defective, VERIS will pay the cost of shipment of both the defective part to the VERIS plant and the replacement part to the original user. As a condition of enforcing any rights or remedies relating to VERIS products, notice of any warranty or other claim relating to the products must be given in writing to VERIS: (i) within 30 days of last day of the applicable warranty period, or (ii) within 30 days of the date of the manifestation of the condition or occurrence giving rise to the claim, whichever is earlier. **IN NO EVENT SHALL VERIS BE LIABLE FOR SPECIAL, DIRECT, INDIRECT, INCIDENTAL OR CONSEQUENTIAL DAMAGES, INCLUDING, BUT NOT LIMITED TO, LOSS OF USE OR PROFITS OR INTERRUPTION OF BUSINESS.** The Limited Warranty and Remedy terms herein apply notwithstanding any contrary terms in any purchase order or form submitted or issued by any user, purchaser, or third party and all such contrary terms shall be deemed rejected by VERIS.

Special Warranty Periods are as follows:

Electronic components, including without limitation, differential pressure transmitters, multivariable transmitters, flow computers, rate or totalizer displays: one (1) year from the date of installation, but not longer than 15 months from the date of shipment from the VERIS factory.

V550 VERIS Verabar® (Flanged Spring-Lock) Installation and Maintenance Manual

*Designs, materials, weights and performance ratings are approximate and subject to change without notice.
Visit armstronginternational.com for up-to-date information.*



Armstrong International - VERIS Flow Measurement Group
5820 Glacier Way, Frederick, CO 80205 - USA Phone: 303-652-8550 Fax: 303-652-8552
armstronginternational.com