



**Monitors, Alarms and Controls Relays
for 1 to 16 channels**

HA20, HA40 & HA71 Gas Detection Controllers



Honeywell Analytics offers a family of gas detection controllers that monitor 2, 4, 8 or 16 points of gas detection. Our controller family delivers robust safety while being cost effective.

The Honeywell digital gas controllers are designed to work in the harshest industrial or commercial environments. A NEMA4x and explosion proof enclosure allows you to place the controllers in all hazardous locations to monitor for toxic gases, combustible gases, and oxygen deficiency.

The controllers are easy to install and feature large graphical LCD display, standard 4-20mA inputs, and non-intrusive inputs for hazardous areas. An optional RS-485 Modbus slave port allows up to 128 HA 40's to be multi-dropped onto a single data highway for interrogation by another Modbus master. A 10-BaseT Ethernet cable is also available for utilizing the popular Modbus TCP/IP protocol.

HA20 2-Channel



HA40 4-Channel



HA71 16-Channel



Optional Stainless Steel Enclosure available for HA20 & HA40

HA20 & HA40 Controllers



Enhanced Technology

- Accepts inputs from up to two (HA20) or four (HA40) 4-20mA sensors transmitters. Internal power supply generates 24VDC and provides 15 watts total system power; optional 50 watts supply available.
- CSA certified to C22.2 NO. 152 for combustible detection and Class I, Div. 2, Groups A,B,C,D CE mark
- 3 independent alarm levels per channel. Relay Acknowledge feature allows silencing of external audible devices during existing alarm conditions
- Graphic LCD readout displays monitored data as bar graphs, trends and engineering units. Alarm LED's flash when new and become steady after acknowledged
- Two standard SPDT common alarm relays for HORN, HIGH, WARN or FAULT

Beneficial Options

- Optional discrete channel alarm relays are available
- Options such as Modbus slave RS-485 serial port, data logging, 4-20mA outputs, discrete alarm relays and others are supported
- Cal Mode offers pushbutton zero/span calibration for direct sensor interface applications. Authorization Mode allows locking of critical configuration variables
- Touch & magnetic keypad for nonintrusive operation in potentially hazardous locations
- NEMA 4X (Div. 2 certified) and Explosion-Proof wall mount packaging options available

The HA20 and HA40 controllers are designed to provide simultaneous display and alarm functions for two or four 4-20mA sensor transmitters. The 4-20mA inputs are standard equipped and ideal for interfacing to sensor transmitters that may be long distances from the controller.

HA20 and HA40 controllers are also user friendly and easy to configure. A Graphic LCD Display shows monitored data as bar graphs, 30 minute trends and engineering units. A touch-and-magnetic keypad allows for non-intrusive operation in potentially hazardous locations. Cal Mode offers pushbutton zero/span calibration for direct sensor interface applications. Authorization Mode allows locking of critical configuration variables.

Measurement ranges in engineering units, adjustable alarm set-points, optional serial interfaces, and many other features offer flexibility to meet most demanding applications. Relay outputs allow control of beacons, horns and other alarm events. Three adjustable alarm levels are provided per channel. Two standard SPDT common alarm relays are for HORN, HIGH, WARN or FAULT alarm conditions.

These controllers meet and exceed national, state and local safety regulations. Even the low-cost NEMA 4X model is CSA certified, CSA certified to C22.2 NO. 152 for combustible detection and Class I, Div. 2, Groups A,B,C,D CE mark NEMA 4X (Div. 2 certified). Explosion-Proof wall mount packaging options are also available.

Other HA40 options include an RS-485 Modbus slave port that allows up to 128 HA40's to be multi-dropped onto a single data highway for interrogation by another Modbus master; choice of six programmable 5 amp SPDT discrete alarm relays; 4-20mA outputs; light stacks; and audible enunciators. HA20 options include 5 amp SPDT discrete alarm relays per channel; 4-20mA outputs; light stacks; and audible annunciators.

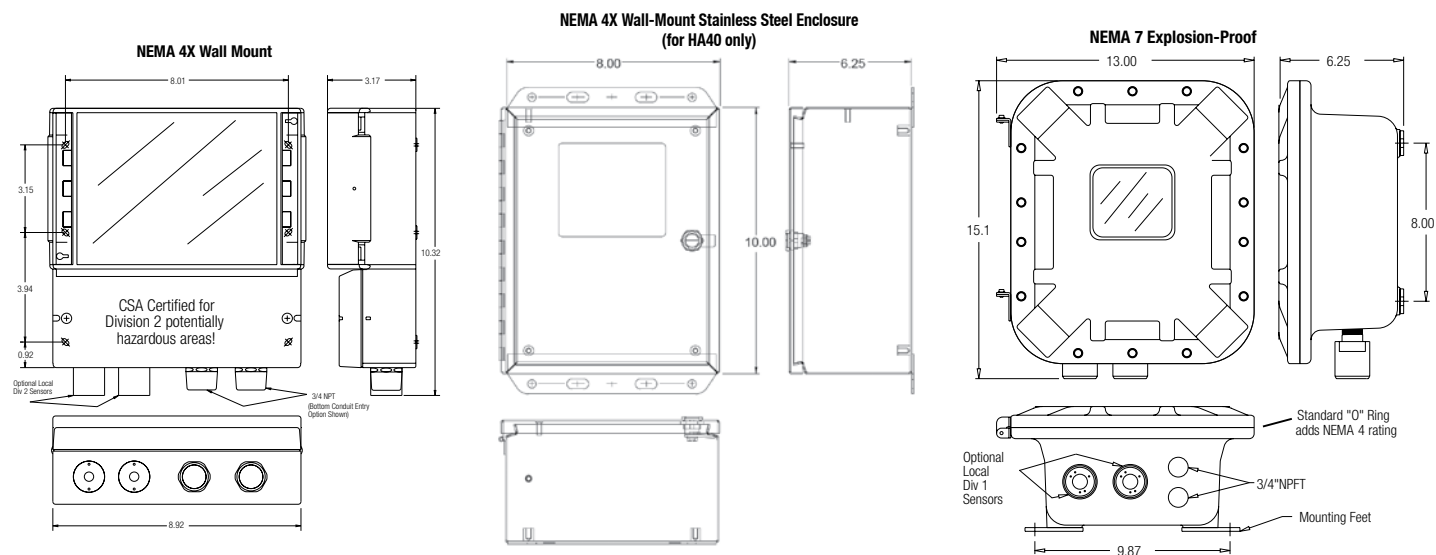

Dimensions in inches

HA71 Gas Detection Controller

Enhanced Technology

- Accepts up to 16 inputs from numerous sensor types
- Inputs may be analog or Modbus allowing data retrieval via RS-485 – reducing wiring costs at installation
- 8 channel display mode and option boards allow economical configuration of systems requiring only 8 channels or less
- Cal Mode offers pushbutton zero/span calibration for direct sensor interface applications
- Authorization Mode locks critical configuration variables
- Graphic LCD displays monitored data as trends, bar graphs and engineering data
- Standard A SPDT common alarm relays for HORN, HIGH, WARN & FAULT
- Dual Modbus RS-485 serial ports and optional phone modem
- 3 adjustable alarm levels per channel
- Relay Acknowledge feature silences external audible devices during existing alarm conditions
- HMI Software monitors up to ten HA71 controllers simultaneously

Beneficial Options

- Alarm event printer interface, direct sensor inputs and discrete alarm relays supported via a 12C expansion bus
- Magnetic keypad available for non-intrusive operation in potentially hazardous locations
- NEMA 4X, Explosion-Proof, surface mount, panel and rack mount packaging

Find out more

www.honeywellanalytics.com

Contact Honeywell Analytics:

Americas

Honeywell Analytics, Inc.
405 Barclay Blvd.
Lincolnshire, IL 60069
USA

Tel: 847.955.8200
Toll-free: 800.538.0363
Fax: 847.955.8210
detectgas@honeywell.com

Technical Services

ha.service@honeywell.com

www.honeywell.com

Please Note:

While ever effort has been made to ensure accuracy in this publication, no responsibility can be accepted for errors or omissions. Data may change, as well as legislation, and you are strongly advised to obtain copies of the most recently issued regulations, standards, and guidelines. This publication is not intended to form the basis of a contract.

H_Controller_DS01074_V3 05/10
© 2010 Honeywell Analytics

The Honeywell Analytics HA71 16 Channel Gas Detection Controller is designed to provide simultaneous display and alarm functions for up to 16 input variables.

Flexible and Configurable— Ideal for Demanding Industrial Applications

The HA71 delivers added value through its multiple capabilities—with simultaneous display and alarm functions for up to 16 input variables. A graphic LCD displays monitored data as trends, bar graphs and engineering units. Three adjustable alarm levels are provided per channel. Relay outputs allow control of beacons, horns and other alarm events. A horn relay may be set for steady or pulsing operation.

Analog inputs may be accepted and conditioned via sensor specific analog input cards. Alternatively, the standard Modbus Master port allows input data to be retrieved from Modbus slave devices including the many Modbus compatible Honeywell Analytics sensor transmitter products.

The HA71 is easy to configure and user friendly. Measurement ranges in engineering units, adjustable alarm set-points, dual serial interfaces and many other features combine to allow the HA71 to satisfy the needs of many demanding applications. It is widely used for centralizing the display and alarm processing functions in critical multipoint monitoring

applications. These include monitoring of ambient gas detection, rotating machinery, tank levels, flow, temperature and others. Nonvolatile memory retains all configuration data indefinitely. A RS-485 Modbus slave port allows up to 128 HA71's to be multidropped onto a single data highway for interrogation by another Modbus master. HA71's may also be cascaded by connecting one unit's master port to another's slave port.

HA71 options such as discrete alarm relays per channel, 4-20mA I/O, direct sensor input conditioning and others are added by connecting appropriate 8 channel boards (2 required for more than 8 channels) to the economical I2C expansion bus. Familiar "telephone style" cables and connectors interface to this bus. This method allows versatile system configuration of options satisfying the most unusual user applications.

The HA-71-HMI (Human Machine Interface) software (optional) has the ability to monitor up to ten HA71 controllers simultaneously, displaying up to 160 points of detection. It provides complete data display and storage, with real-time channel data available in 24-hour or 15-minute trends, including historical alarm and maintenance data.

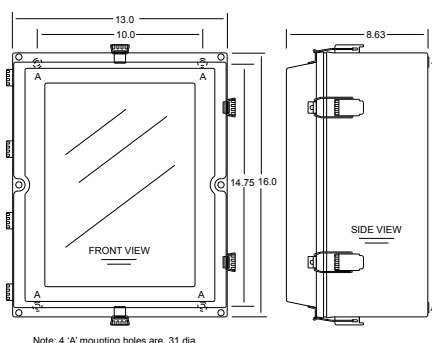

NEMA 4x Wall Mount

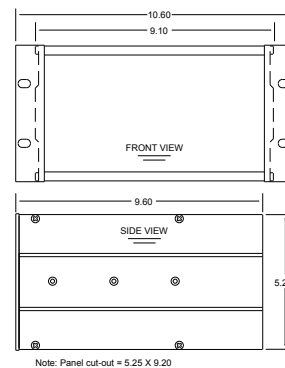

RACK / PANEL MOUNT
(19" RACK SPREADER PLATES &
PANEL MOUNT BEZEL NOT SHOWN)

Europe, Middle East, Africa

Life Safety Distribution AG
Weiherallee 11a
CH-8610 Uster
Switzerland
Tel: +41 (0)44.943.4300
Fax: +41 (0)44.943.4398
gasdetection@honeywell.com

Asia Pacific

Honeywell Analytics, Asia Pacific
#508, Kolon Science Valley (1)
187-10 Guro-Dong, Guro-Gu
Seoul, 152-050
Korea
Tel: +82 (0)2.2025.0307
Fax: +82 (0)2.2025.0329
analytics.ap@honeywell.com

Honeywell