

Hammer Union Pressure Transmitter User Manual

For The Recalibratable HU1502I

Table of Contents

Introduction	iii
Warranty and Warranty Restrictions	iv
Chapter 1: Specifications and Options.....	1
Dimensions	1
Specifications	2
Model Number Configurator.....	3
Electrical Connectors and Pinout Table	4
Chapter 2: Installation and Removal Procedures and Notes.....	5
Tools Needed.....	5
Physical Installation	5
Electrical Installation	5
Shunt Calibration Procedures.....	6
Removal Instructions	6
Chapter 3: Maintenance	7
General Care	7
Repair and Returns.....	7
Chapter 4: Recalibration Procedure	8
Recalibration Wiring Diagrams	8
Tools Needed.....	9
Recalibration Set Up - Computer.....	9
Recalibration Set Up - HU1502SS/I	9
Software User Interface.....	10-11
Recalibration Procedure.....	11-12
Chapter 5: Hazardous Location Installation and Certification.....	13
Intrinsically Safe Wiring Diagram	13
CSA Certificate of Compliance	14-17
EU Declaration of Conformity	18
IECEX Certificate of Conformity	19-23

Introduction

Thank you for purchasing a Hammer Union Pressure Transmitter from APG. We appreciate your business! Please take a few minutes to familiarize yourself with your Hammer Union and this manual.

APG's Recalibratable Hammer Union Pressure Transmitters are designed for the harsh environments of land-based and offshore drilling installations. Designed specifically for use with the 1502 Hammer Wing Union, the HU1502I features a NPT-sealed port for digital zero and span recalibration. The HU1502I is constructed from NACE compliant incoloy for use with sour gas (H₂S), sodium chloride (NaCl), calcium chloride (CaCl₂), and in corrosive environments.

Reading your label

Every APG instrument comes with a label that includes the instrument's model number, part number, serial number, and a wiring pinout table. Please ensure that the part number and pinout table on your label match your order.

Electrical ratings



Input: 10 to 28 VDC; Output: 4-20 mA / 0-5 VDC (per order)

Class I, Division 1, Groups C, D

Class I, Zone 0

Ex ia IIB T4: -40°C to 85°C; Enclosure Type IP67

AEx ia IIB T4: -40°C to 85°C; Enclosure Type IP67

V_{max} U_i = 28VDC, I_{max} I_i = 110mA, P_{max} P_i = 1W, C_i = 60.89nF, L_i = 7.7mH

The following approvals only apply to the L24 (4-20mA) version

ATEX Directive: 0344

Sira 13ATEX2023



II 1G Ex ia IIB T4 Ga

Ta: -40°C to 85°C

U_i ≤ 28 V, I_i ≤ 110 mA, P_i ≤ 1 W, C_i ≤ 60.89 nF, L_i ≤ 7.7 mH

IECEX CSA 13.0004
Ex ia IIB T4 Ga

i **IMPORTANT:** Recalibratable Hammer Union Pressure Transmitter **MUST** be installed according to drawing 9002460 (Intrinsically Safe Wiring Diagram) on page 13 to meet listed approvals. Faulty installation will invalidate all safety approvals and ratings.

Warranty and Warranty Restrictions

This product is covered by APG's warranty to be free from defects in material and workmanship under normal use and service of the product for 24 months. For a full explanation of our Warranty, please visit <https://www.apgsensors.com/about-us/terms-conditions>. Contact Technical Support to receive a Return Material Authorization before shipping your product back.

Scan the QR code below to read the full explanation of our Warranty on your tablet or smartphone.



Chapter 1: Specifications and Options

- **Dimensions**

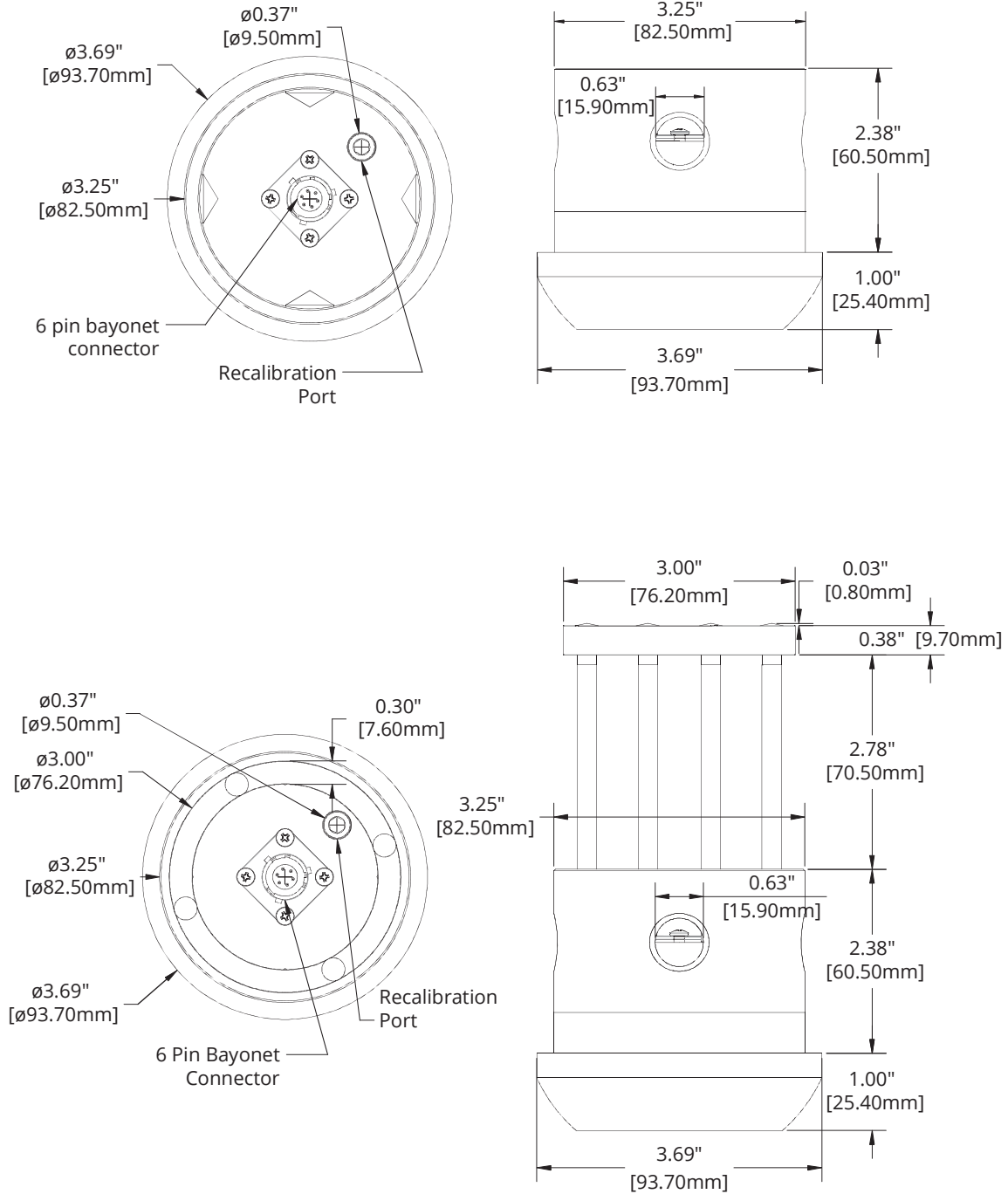

• Specifications

Performance

Pressure Ranges	0 to 20K PSIS (Per Part Number)
Analog Output	4-20mA, 0-5VDC
Over Pressure	1.5X Full Scale, or limit of wing nut fitting, whichever is smallest
Burst Pressure	3.0X Full Scale, or limit of wing nut fitting, whichever is smallest
Life	10 million cycles, minimum

Accuracy

Linearity, Hysteresis & Repeatability	±0.25% of Full Scale (BFSL)
Thermal Zero Shift	±0.026% FSO/°C (±0.01% FSO/°F)
Thermal Span Shift	±0.026% FSO/°C (±0.01% FSO/°F)

Environmental

Operating Temperature	-40 to 85°C	(-40 to 185°F)
Compensated Temperature	-40 to 65°C	(-40 to 150°F)
Enclosure Protection	IP67/IP65	

Electrical

Supply Voltage	10-28 VDC on sensor
Output Signal @ 21°C	4-20 mA: 3-30 mA max. 0 to 5 VDC: 7mA max

Materials of Construction

Wetted Materials	Incoloy 925 NACE MR-01-75 and ISO 15156-3
Enclosure	316L Stainless Steel

Mechanical

Pressure Connection	WECO® standard 1502 or equivalent
Weight	2.3kg (5.10 lbs)

i IMPORTANT: To maintain the IP67/65 rating, the equipment shall be installed with a certified IP67/65 mating connector.

Electrical Connectors and Pinout Table

Face view of male connector on HU

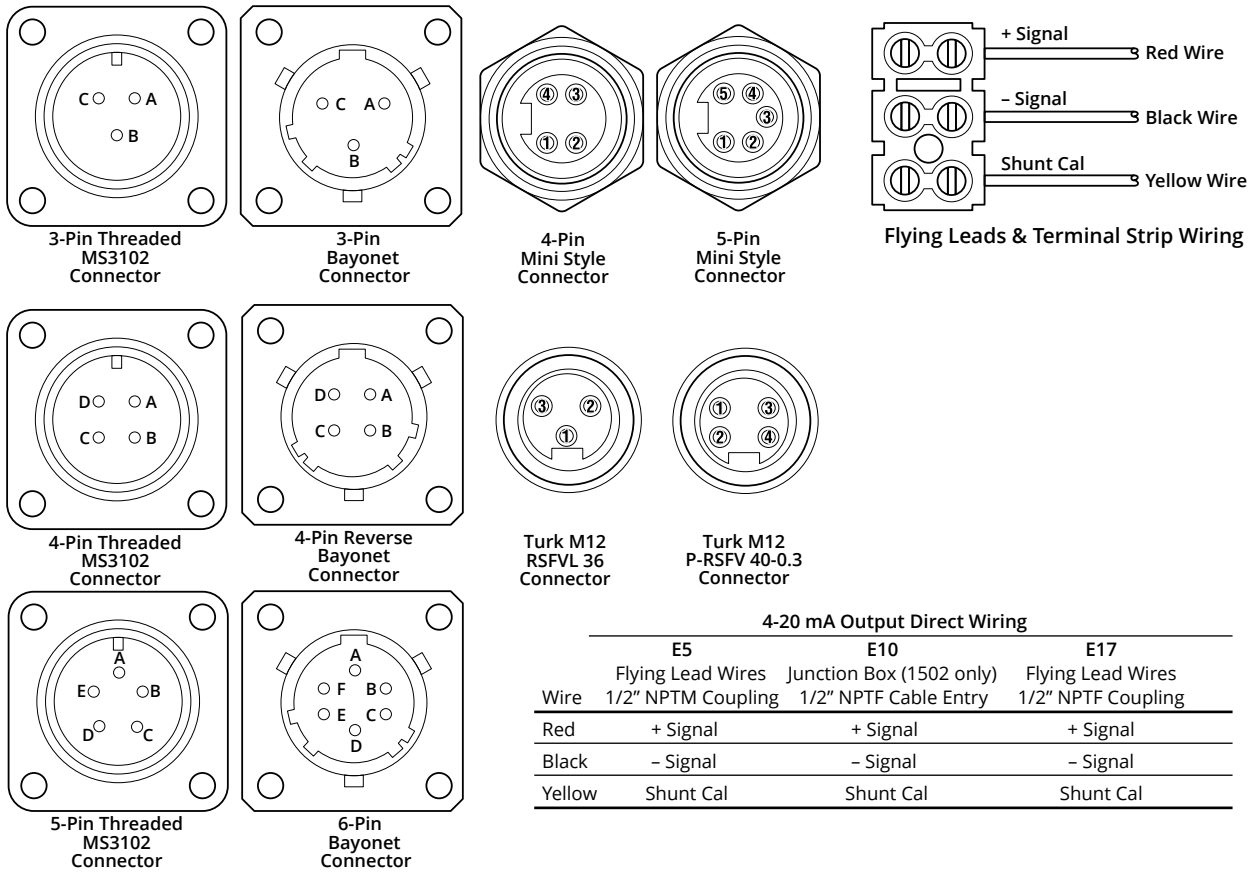

4-20 mA Output Direct Wiring			
	E5	E10	E17
	Flying Lead Wires	Junction Box (1502 only)	Flying Lead Wires
Wire	1/2" NPTM Coupling	1/2" NPTF Cable Entry	1/2" NPTF Coupling
Red	+ Signal	+ Signal	+ Signal
Black	- Signal	- Signal	- Signal
Yellow	Shunt Cal	Shunt Cal	Shunt Cal

Pin	0 to 5 VDC Output		4-20 mA Output					
	E3 4 pin MS3102 Electroplate Nickel	E14 6 pin Bayonet Stainless Steel	E1 4 pin Mini Nickel Plated Zinc	E2 5 pin Mini Nickel Plated Zinc	E6 3 pin M12 Stainless Steel	E7 4 pin Bayonet Stainless Steel	E8 5 pin MS3102 Stainless Steel	E9 3 pin MS3102 Stainless Steel
A (1)	+ Power	+ Power	+ Signal	+ Signal	No Connection	+ Power/Signal	No Connection	No Connection
B (2)	- Power	+ Signal	- Signal	- Signal	+ Power/Signal	- Power/Signal	- Power/Signal	+ Power/Signal
C (3)	+ Signal	-Power	Shunt Cal	No Connection	- Power/Signal	Shunt Cal	+ Power/Signal	- Power/Signal
D (4)	- Signal	- Signal	No connection	Shunt Cal	-	No Connection	Shunt Cal	-
E (5)	-	+Shunt Cal	-	No Connection	-	-	No Connection	-
F	-	-Shunt Cal	-	-	-	-	-	-

Note: Mating connectors sold separately.

Pin	4-20 mA Output								
	E11 4 pin MS3102 Stainless Steel	E13 7 Pin Jup./Souriau Stainless Steel	E15 6 pin Bayonet Stainless Steel	E18 4 pin ROTA Stainless Steel	E20 4 pin M12 Stainless Steel	E28 6 pin Bayonet Stainless Steel	E40 3 pin Bayonet Stainless Steel	E45 6 pin Bayonet Stainless Steel	E49 6 pin Bayonet Stainless Steel
A (1)	No Connection	+ Power/Signal	+ Power/Signal	+ Power/Signal	-Power/Signal	+ Power/Signal	+ Power/Signal	+ Power/Signal	+ Power/Signal
B (2)	- Power/Signal	- Power/Signal	- Power/Signal	- Power/Signal	+ Power/Signal	- Power/Signal	- Power/Signal	- Power/Signal	- Power/Signal
C (3)	+ Power/Signal	No Connection	No Connection	Case Ground	No Connection	No Connection	Shunt Cal	No Connection	No Connection
D (4)	Case Ground	No Connection	Case Ground	Shunt Cal	Case Ground	No Connection	-	Case Ground	No Connection
E (5)	-	Shunt Cal	+ Shunt Cal	-	-	No Connection	-	Shunt Cal	Shunt Cal
F (6)	-	No Connection	- Shunt Cal	-	-	No Connection	-	No Connection	No Connection
G (7)	-	No Connection	-	-	-	-	-	-	-

Note: Mating connectors sold separately.

Chapter 2: Installation and Removal Procedures and Notes

• Tools Needed

You will need the following tools to install your HU1502I Hammer Union Pressure Transmitter:

- A hammer
- 1502 wing nut

 **DANGER:** Mismatched unions and nuts can result in dangerous or hazardous equipment failures. Always check identifications on both union pieces and nuts prior to installation. Only use pieces with matching union figure numbers, sizes, and pressure ratings.

• Physical Installation

- Ensure mating union faces are clean, dry, and free of debris.
- Mate your Hammer Union Pressure Transmitter onto the socket.
- Place the wing nut on the Transmitter and spin into place.
- Hammer the wing nut until tight.

• Electrical Installation

- Check the pinout table on your Hammer Union Pressure Transmitter against your order.
- Check that your electrical system wiring matches the pinout table on your Hammer Union.
- For instruments with connectors, make the connection. Otherwise, connect the flying leads or junction box to your electrical system.

 **IMPORTANT:** To maintain the IP67/65 rating of your Hammer Union, you must use a certified IP67/65 mating connector.

• Shunt Calibration Procedures

APG's Hammer Union Pressure Transmitters can be configured with either a single-pin shunt calibration or two-pin switched shunt calibration.

Single-Pin Shunt Calibration Procedure

APG's Hammer Union Pressure Transmitters with single-pin shunt cal provide a full scale output (20.0 mA or 5 VDC) when 10 to 28 VDC is applied to the designated Shunt Cal pin. See the pinout chart on your Hammer Union Pressure Transmitter's label.

- Check the pinout table on your Hammer Union Pressure Transmitter.
- For 0 - 5 VDC Hammer Unions, connect +/- Power and +/- Signal, with a volt meter connected across +/- Signal.
- For 4-20 mA Hammer Unions, connect +/- Signal, with - Signal connected through an Ammeter.
- Apply 10 to 28 VDC to the Shunt Cal pin.
- If the instrument electronics are operating properly, the output signal will go to full scale (5 VDC or 20 mA).

Two-Pin Shunt Calibration Procedure

APG's Hammer Union Pressure Transmitters with two-pin shunt cal provide a full scale output (20.0 mA or 5 VDC) when + Shunt is shunted to - Shunt. This is usually accomplished via an external switch. See the pinout chart on your Hammer Union Pressure Transmitter's label.

- Check the pinout table on your Hammer Union Pressure Transmitter.
- For 0 - 5 VDC Hammer Unions, connect +/- Power and +/- Signal, with a volt meter connected across +/- Signal, and an open switch between + Shunt Cal and - Shunt Cal.
- For 4-20 mA Hammer Unions, connect +/- Signal, with - Signal connected through an Ammeter, and an open switch between + Shunt Cal and - Shunt Cal.
- Close the open switch between + Shunt Cal and - Shunt Cal, effectively applying power to - Shunt Cal. (+ Power for 0 - 5 VDC, and + Signal for 4 - 20 mA, is tied to + Shunt Cal inside the Hammer Union)
- If the instrument electronics are operating properly, the output signal will go to full scale (5 VDC or 20 mA) when the switch is closed.

• Removal Instructions

Removing your Hammer Union Pressure Transmitter from service must be done with care. It's easy to create an unsafe situation if you are not careful to follow these guidelines:

- Make sure the pressure is completely removed from the line where your sensor is installed. Follow any and all procedures for safely isolating any media contained inside the line or vessel.
- Remove the Hammer Union wing nut.
- Remove your Pressure Transmitter.
- Clean the sensor's fitting and diaphragm of any debris (see above instructions) and inspect for damage.
- Store your sensor in a dry place, at a temperature between -40° F and 180° F.

 **DANGER:** Removing your Hammer Union Pressure Transmitter while there is still pressure in the line could result in injury or death.

Chapter 3: Maintenance

• General Care

Your Hammer Union Pressure Transmitter is designed to be maintenance free. As such, there are no customer servicable parts on or in the device. However, in general, you should:

- Avoid touching the diaphragm. Contact with the diaphragm, especially with a tool, could permanently shift the output and ruin accuracy.
- Clean the diaphragm or the diaphragm bore only with extreme care. If using a tool is required, make sure it does not touch the diaphragm.
- See Chapter 4 Recalibration Procedure for recalibration instructions.

• Repair and Returns

Should your Hammer Union Pressure Transmitter require service, please contact the factory via phone, email, or online chat. We will issue you a Return Material Authorization (RMA) number with instructions.

- Phone: 888-525-7300
- Email: sales@apgsensors.com
- Online chat at www.apgsensors.com

Please have your Hammer Union Pressure Transmitter's part number and serial number available. See Warranty and Warranty Restrictions for more information.

i IMPORTANT: All repairs and adjustments of the Recalibratable HU1502I Pressure Transmitter must be made by the factory. Modifying, disassembling, or altering the Recalibratable HU1502I Pressure Transmitter, other than factory approved recalibration, is strictly prohibited.

Chapter 4: Recalibration Procedure

- Recalibration Wiring Diagrams

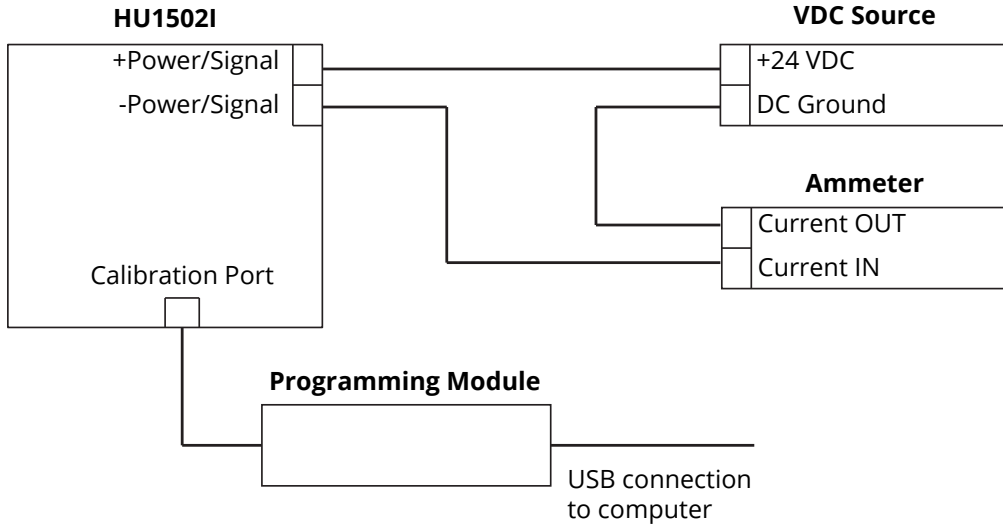

Figure 4.1

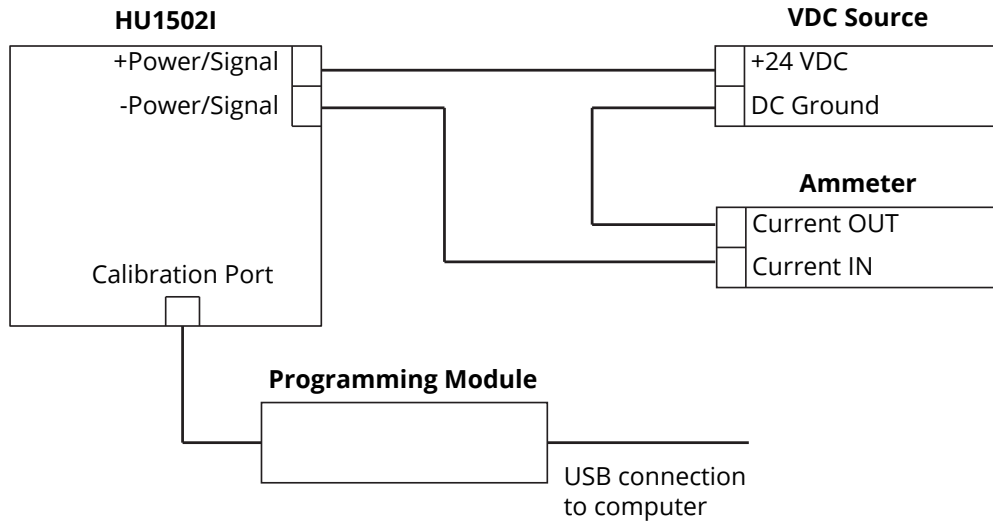

Figure 4.2

- **Tools Needed**

You will need the following tools to recalibrate your HU1502I Hammer Union Pressure Transmitter:

- A hammer
- 1502 wing nut
- Hex driver
- +24 VDC source
- Ammeter or voltmeter (per HU1502I output)
- Computer with USB port
- Hammer Union test station capable of applying calibrated full scale pressure to the HU1502I

- **Recalibration Set Up - Computer**

Prior to connecting your HU1502I Pressure Transmitter to the Programming Module:

- Install the Hammer Union Calibrator software on the computer to be used for recalibration.

 Note: Contact the factory for the Hammer Union Calibrator software.

 **IMPORTANT:** Hammer Union Calibrator software must be installed on a computer with a USB port.

- **Recalibration Set Up - HU1502I**

Setting up your HU1502I Pressure Transmitter for recalibration must be done with care. It's easy to create an unsafe situation if you are not careful to follow these guidelines:

- Install the HU1502I in a test station capable of applying calibrated full scale pressure to the transducer. Begin with 0 pressure applied to the HU1502I.
- Use a ratchet and Allen socket to remove the NPT plug covering the recalibration port.
- Connect the HU1502I to a 24 VDC source and an ammeter or voltmeter. Consult the pinout on the HU1502I label and the wiring diagrams on page 8 (Figure 4.1 for 4-20 mA Output, Figure 4.2 for 0-5 VDC output) to ensure correct pin/wire connections.
- Power on VDC Source and ammeter/voltmeter. The meter should show a reading at or near zero pressure (4 mA or 0 VDC) if everything is connected correctly.
- Plug 3.5mm on Programming Module into HU recalibration port.

- **Software User Interface**

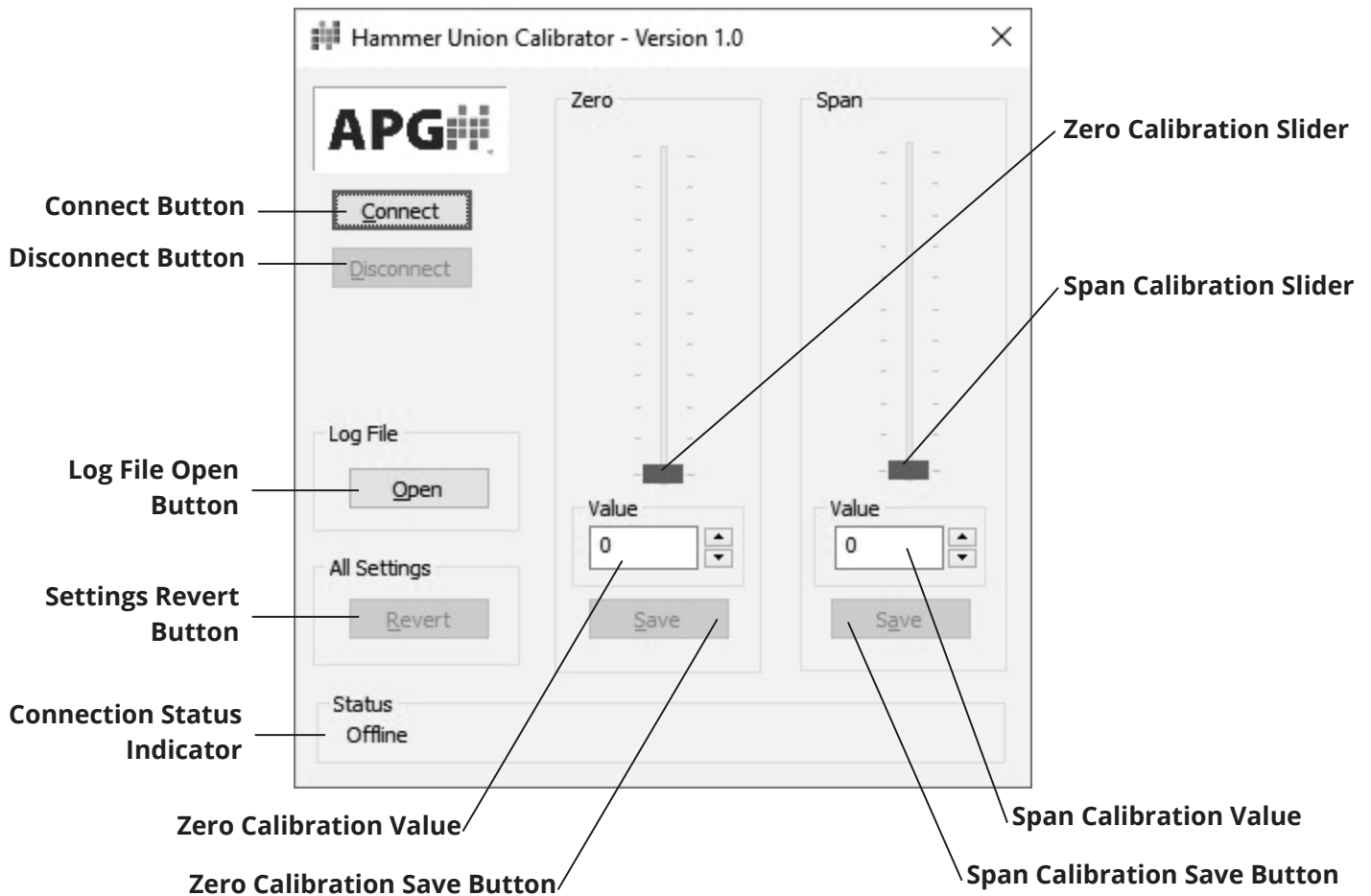

Figure 4.3

Button and Slider operations and Displays

Connect Button:

Initiates connection between Hammer Union Calibrator software and Recalibratable HU1502I.

Disconnect Button:

Ends connection between Hammer Union Calibrator software and Recalibratable HU1502I.

Log File Open Button:

Opens Log File txt. Every attempt to write a calibration value is logged as successful or unsuccessful.

Settings Revert Button:

Clears UNSAVED calibration adjustments. Sliders will not reset, but ammeter/voltmeter will display initial output value.

Zero Calibration Slider:

Adjusts zero output (4 mA/0 VDC). Can be adjusted with mouse or ↑ and ↓ buttons.

Zero Calibration Value:

Displays current calibration adjustment. Can be cleared via Settings Revert Button before clicking Zero Calibration Save Button. CANNOT read current calibration value on Recalibratable HU1502I.

Zero Calibration Save Button:

Writes Zero Calibration Value to Recalibratable HU1502I.

Span Calibration Slider:

Adjusts full scale output (20 mA/5 VDC). Can be adjusted with mouse or ↑ and ↓ buttons.

Span Calibration Value:

Displays current calibration adjustment. Can be cleared via Settings Revert Button before clicking Span Calibration Save Button.

Span Calibration Save Button:

Writes Span Calibration Value to Recalibratable HU1502I.

Connection Status Indicator:

Displays current status of connection between Hammer Union Recalibrator software and Recalibratable HU1502I, and success or failure of write attempts to Recalibratable HU1502I (See Figure 4.5).

• Recalibration Procedure

After completing the set up instructions above, follow the these steps to recalibrate your HU1502I:

1. Connect programming unit to computer with Hammer Union Calibrator software already installed via USB port.
2. Launch Hammer Union Calibrator software.
3. Click Connect Button (See Figure 4.3) to initiate connection between Hammer Union Calibrator software and HU1502I. Wait for Connection Status Indicator to read "Open Successful" (See Figure 4.4).
- 4A. With 0 pressure applied to the HU1502I, adjust Zero Calibration Slider (See Figure 4.3) until ammeter reads 4 mA or voltmeter reads 0 VDC, to the desired precision. Allow 1 second for ammeter/voltmeter reading to stabilize after adjusting slider.
- 4B. When desired reading shows on ammeter/voltmeter, press Zero Calibration Save Button.
- 5A. Apply full scale pressure to HU1502I.
- 5B. Adjust Span Calibration Slider until ammeter reads 20 mA or voltmeter reads 5 VDC. Allow 1 second for ammeter/voltmeter reading to stabilize after adjusting slider.
- 5C. When desired reading shows on ammeter/voltmeter, press Span Calibration Save Button.
- 5D. Release pressure applied to HU1502I.
6. Repeat Steps 4A - 5D as necessary (usually two or three iterations) until Zero and Span readings are calibrated to desired precision.
7. To reinstall 1/8" plug in recalibration port, wrap the plug with 3 wraps of PTFE tape. Tighten the plug to 1 full turn past hand-tight using an Allen socket and ratchet.

i IMPORTANT: Zero Calibration Value and Span Calibration Value are not written unless the corresponding Save Button is clicked.

pencil Note: Any adjustments made can be discarded BEFORE clicking a Calibration Save Button by clicking the Settings Revert Button (See Figure 4.3). Slider position and value will not reset, but ammeter/voltmeter reading will reset to value prior to slider adjustment.

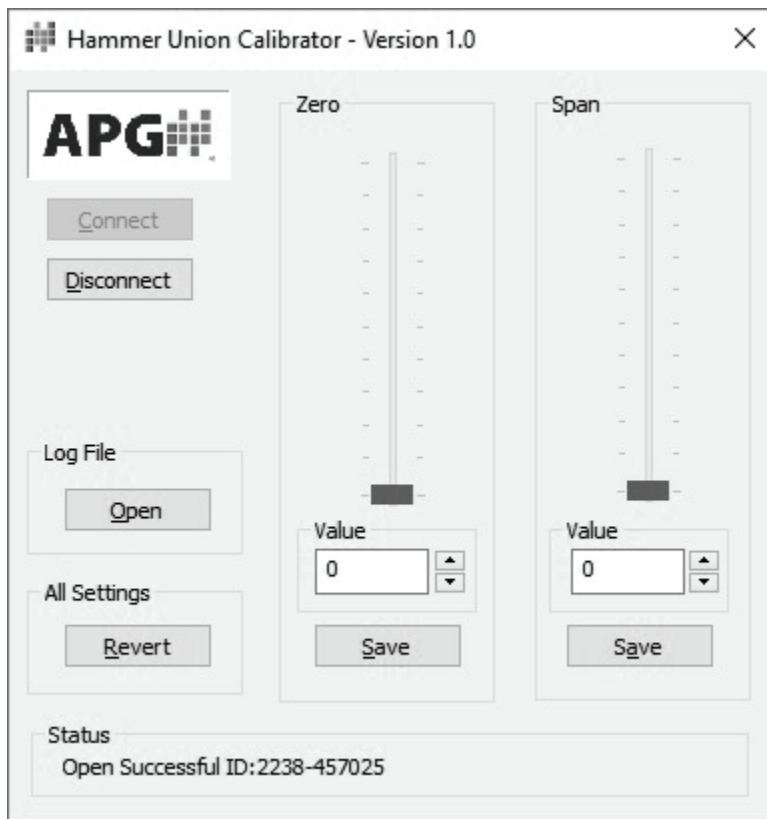

Figure 4.4

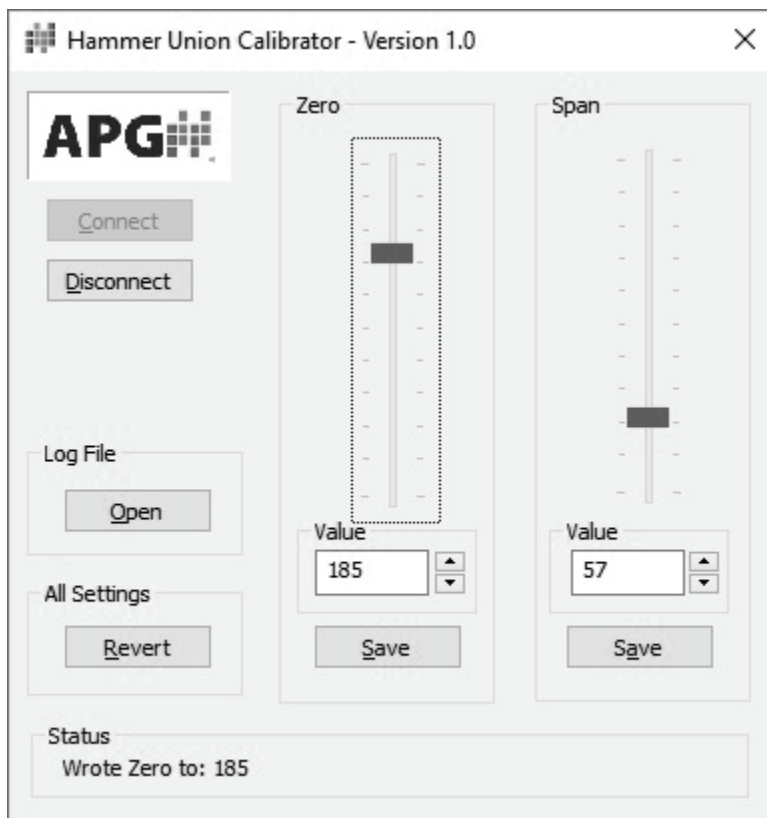
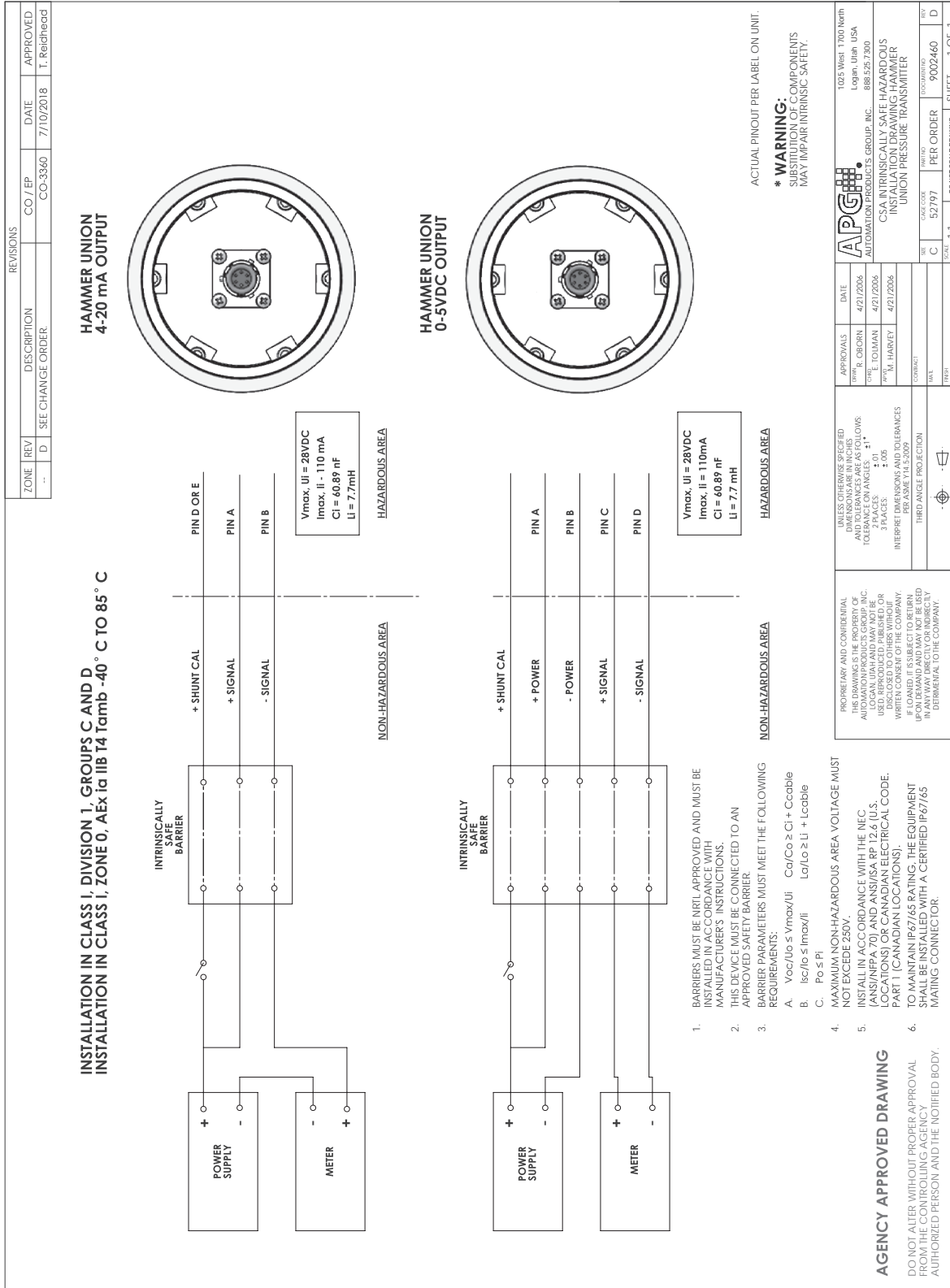

Figure 4.5

Chapter 5: Hazardous Location Installation and Certification

Intrinsically Safe Wiring Diagram





Certificate: 1916494
Project: 70177689

Master Contract: 237484
Date Issued: 2018-06-26

Conditions of Acceptability

- To maintain IP67/65 rating, the equipment shall be installed with a certified IP67/65 mating connector.
- This device must be connected to a NRTL approved safety barrier

Note: Suffixes are added to indicate options not affecting safety.

APPLICABLE REQUIREMENTS

CAN/CSA-C22.2 No. 0-10 (R2015)	General Requirements – Canadian Electrical Code, Part II
CAN/CSA-C22.2 No. 60950-1-07	Information technology Equipment – Safety – Part 1: General Requirements
CAN/CSA-C22.2 No. 60079-0:15	Explosive Atmospheres - Part 0: Equipment - General requirements
CAN/CSA-C22.2 No. 60079-11:14	Explosive Atmospheres – Part 11: Equipment protection by intrinsic safety "i"
UL 60950-1 Edition 2	Information technology Equipment – Safety – Part 1: General Requirements
ANSI/UL 60079-0:13	Electrical Apparatus for Explosive Gas Atmospheres - Part 0: General Requirements
ANSI/UL 60079-11:13	Electrical apparatus for Explosive Gas Atmospheres - Part 11: Intrinsic Safety “i”



Certificate: 1916494
Project: 70177689

Master Contract: 237484
Date Issued: 2018-06-26

MARKINGS

The manufacturer is required to apply the following markings:

- Products shall be marked with the markings specified by the particular product standard.
- Products certified for Canada shall have all Caution and Warning markings in both English and French.

Additional bilingual markings not covered by the product standard(s) may be required by the Authorities Having Jurisdiction. It is the responsibility of the manufacturer to provide and apply these additional markings, where applicable, in accordance with the requirements of those authorities.

The products listed are eligible to bear the CSA Mark shown with adjacent indicators 'C' and 'US' for Canada and US (indicating that products have been manufactured to the requirements of both Canadian and U.S. Standards) or with adjacent indicator 'US' for US only or without either indicator for Canada only.

- (1) Submitter's name, trademark, or the CSA file number (adjacent the CSA Mark).
- (2) Catalogue / Model designation.
- (3) Entity Parameters
- (4) Date code / Serial number traceable to month and year of manufacture.
- (5) Hazardous Location designations.
- (6) The words "Exia, INTRINSICALLY SAFE".
- (7) Temperature code T4.
- (8) Ambient -40°C to +85°C
- (9) Maximum working pressure.
- (10) Enclosure Type: IP 65/67
- (11) The CSA Mark with the c and us qualifiers as applicable.

The products listed above are eligible to bear the CSA Mark with adjacent indicators "C" and "US" for Canada and US or with adjacent indicator "US" for US only or without either indicator for Canada only.



Certificate: 1916494
Project: 70177689

Master Contract: 237484
Date Issued: 2018-06-26

Supplement to Certificate of Compliance

Certificate: 1916494 **Master Contract:** 237484 (237484)

*The products listed, including the latest revision described below,
are eligible to be marked in accordance with the referenced Certificate.*

Product Certification History

Project	Date	Description
70177689	2018-06-26	Update CSA Report 1916494 to add two new housing designs, specified as HU-1502I and HU-1502SS. Upgrade all models from CSA 142-M1987 to UL/CSA 61010-1.
2703264	2014-09-15	Update to Report 1916494 to revise input filter board.
2615564	2013-04-02	Update to include revised drawings with minor changes.
2517307	2012-08-09	Update to include a new EMI board within the Hammer Union Pressure Sensor as well an IP65/67 certification for the sensor enclosure.
1916494	2007-05-30	Supersedes report 1854327 (sub report 1726089) to change listing to show Ex ia and AEx ia.

- **EU Declaration of Conformity**

EU *Declaration of Conformity*



Manufacturer's Name: Automation Products Group Inc.

Address: 1025 West 1700 North
Logan, UT 84321

Tel: (435) 753-7300
Fax: (435) 753-7490
Email: sales@apgsensors.com
Web: www.apgsensors.com

Declares that the product:

Product Name: HU-L24-IS-nnK-PSIS-Enn-Pnn-Knn-Bnn, HU1502I, and
HU1502SS Pressure Transmitter

Conforms to:

ATEX Directive 2014/34/EU

- EC Type Examination Certificate: Sira 13ATEX2023X
Sira 0518

Sira Certification Service, Rake Lane, Eccleston, Chester, CH4 9JN, England

Description of Equipment or Protective System:

The equipment measures a pressure and provides a 4-20mA output signal proportional to the measured pressure.

Series: HU-L24 Series, HU1502I Series and HU1502SS Series

Conforms to the following Standards

EN 60079-0:2012/A11:2013
EN 60079-11:2012

Markings: : ATEX: Ex II 1G Ex ia IIB T4 Ga (Ta = -40°C to +85°C)



Supplementary Information:

The product described in this Declaration of Conformity complies with the Applicable European Directives and relevant sections of the Applicable International Standards. The signature on this document authorizes the distinctive European mark to be applied to the equipment described.

Authorized Signature: _____

Karl Reid
Karl Reid, Product Line Manager

• **IECEX Certificate of Conformity**

		<h1>IECEX Certificate of Conformity</h1>	
<p>INTERNATIONAL ELECTROTECHNICAL COMMISSION IEC Certification Scheme for Explosive Atmospheres <small>for rules and details of the IECEX Scheme visit www.iecex.com</small></p>			
Certificate No.:	IECEX CSA 13.0004X	Issue No: 2	<u>Certificate history:</u> Issue No. 2 (2018-07-20) Issue No. 1 (2014-10-17) Issue No. 0 (2013-03-08)
Status:	Current	Page 1 of 4	
Date of Issue:	2018-07-20		
Applicant:	Automation Products Group, Inc. 1025 W 1700 N Logan Utah, 84321 United States of America		
Equipment:	4-20mA Pressure Transmitter (HU-L24, HU-1502SS, and HU-1502I)		
Optional accessory:			
Type of Protection:	Ex ia		
Marking:	Ex ia IIB T4 Ga Ta: -40°C to +85 °C		
Approved for issue on behalf of the IECEX Certification Body:	Dorin Stochitoiu		
Position:	Technical Advisor		
Signature: (for printed version)	_____		
Date:	_____		
<ol style="list-style-type: none"> 1. This certificate and schedule may only be reproduced in full. 2. This certificate is not transferable and remains the property of the issuing body. 3. The Status and authenticity of this certificate may be verified by visiting the Official IECEX Website. 			
Certificate issued by: <div style="display: flex; justify-content: space-around; align-items: center;"> <div style="text-align: center;"> <p>CSA International 178 Rexdale Boulevard Toronto, Ontario M9W 1R3 Canada</p> </div> <div style="text-align: center;">  </div> </div>			



IECEX Certificate of Conformity

Certificate No: IECEX CSA 13.0004X Issue No: 2

Date of Issue: **2018-07-20** Page 2 of 4

Manufacturer: **Automation Products Group, Inc.**
1025 W 1700 N Logan
Utah, 84321
United States of America

Additional Manufacturing location(s):

This certificate is issued as verification that a sample(s), representative of production, was assessed and tested and found to comply with the IEC Standard list below and that the manufacturer's quality system, relating to the Ex products covered by this certificate, was assessed and found to comply with the IECEx Quality system requirements. This certificate is granted subject to the conditions as set out in IECEx Scheme Rules, IECEx 02 and Operational Documents as amended.

STANDARDS:

The apparatus and any acceptable variations to it specified in the schedule of this certificate and the identified documents, was found to comply with the following standards:

IEC 60079-0 : 2011 Explosive atmospheres - Part 0: General requirements
Edition:6.0

IEC 60079-11 : 2011 Explosive atmospheres - Part 11: Equipment protection by intrinsic safety "I"
Edition:6.0

*This Certificate **does not** indicate compliance with electrical safety and performance requirements other than those expressly included in the Standards listed above.*

TEST & ASSESSMENT REPORTS:

A sample(s) of the equipment listed has successfully met the examination and test requirements as recorded in

Test Report:

[CA/CSA/ExTR13.0004/00](#)

[CA/CSA/ExTR13.0004/01](#)

[CA/CSA/ExTR13.0004/02](#)

Quality Assessment Report:

[NL/DEK/QAR13.0027/03](#)



IECEX Certificate of Conformity

Certificate No: IECEx CSA 13.0004X

Issue No: 2

Date of Issue: **2018-07-20**

Page 3 of 4

Schedule

EQUIPMENT:

Equipment and systems covered by this certificate are as follows:

The HU-L24-IS-nnK-PSIS-Enn-Pnn-Knn-Bnn, HU-1502SS-Ln, and HU-1502I-Ln 4-20mA Pressure Transmitters consists of encapsulated electronics on two, separate printed circuit boards which connects to a silicon resistive strain gage arranged in a Wheatstone bridge configuration mounted in a two-part housing. The upper half of the housing has one of the two printed circuit boards, dedicated for EMI protection. The bottom half of the two part housing is comprised of the second printed circuit board (main electronics) and the strain gage element which are mounted on a thin walled section of the enclosure. The strain gage connects to the main board in the lower housing via a ribbon cable. There is no direct process connection between the pressure sensor and the external environment being measured. External electrical connections are made to the connector fitted at one end.

The equipment has the following safety description (Entity Parameters):

Ui = 28V, Ii = 110mA, Pi = 1W, Ci = 60.89nF, Li = 7.7mH

SPECIFIC CONDITIONS OF USE: YES as shown below:

- To maintain IP67/65 rating, the equipment shall be installed with a certified IP67/65 mating connector.
- This device must be connected to an approved safety barrier (located in a safe area).



IECEX Certificate of Conformity

Certificate No: IECEX CSA 13.0004X

Issue No: 2

Date of Issue: **2018-07-20**

Page 4 of 4

DETAILS OF CERTIFICATE CHANGES (for issues 1 and above):

Issue 1: The change involves modification of the EMI board to add a common mode choke and protective circuitry to better protect the Hammer Union sensor against surges and fast transients. The Li parameter has been modified as a result. The customer also lowered the Ui value.

Issue 2: The change involves the addition of two new models, which are enclosure variants of the existing model. These two new models are denoted as the HU-1502SS and the HU-1502I. No electrical changes.



Automation Products Group, Inc.

Tel: 1/888/525-7300 • Fax: 1/435/753-7490 • www.apgsensors.com • sales@apgsensors.com