

HOBO[®]

Energy Logger

Data Logger & Modules

User's Guide

onset[®]

Part #: MAN-H22
Doc #: 9857-G



DANGER! HIGH VOLTAGE HAZARD!



This logger can be used with sensors that may be installed in an energized electrical enclosure or on an energized conductor. Installation of sensors in an energized electrical enclosure or on an energized conductor can result in severe injury or death. These sensors are for installation by qualified personnel only. To avoid electrical shock, do not install or service these sensors unless you are qualified to do so. Disconnect and lock out all power sources during installation and servicing. Please read the user's manual for instructions and use.

Contact Information

For support, please contact the company that you bought the products from: Onset Computer Corporation or an Onset Authorized Dealer.

Onset Computer Corporation
470 MacArthur Blvd.
Bourne, MA 02532

Mailing Address:

P.O. Box 3450
Pocasset, MA 02559-3450

Phone: 1-800-LOGGERS (1-800-564-4377) or 508-759-9500

Fax: 508-759-9100

Hours of Operation: Customer Service, 8 AM to 5 PM ET, Monday through Friday,
Technical Support, 8 AM to 8 PM ET, Monday through Friday

E-mail: loggerhelp@onsetcomp.com

Main Onset Web site: www.onsetcomp.com

If you purchased the products through an Onset Authorized Dealer, you can also refer to www.hobohelp.com for support information.

© 2009–2014 Onset Computer Corporation. All rights reserved.

Onset, HOB0, HOB0ware, and FlexSmart are trademarks or registered trademarks of Onset Computer Corporation for its data logger products and configuration/ interface software. Keyspan is a trademark of InnoSys Inc. Duracell is a registered trademark of Duracell. Energizer is a registered trademark of Eveready Battery Company, Inc. All other trademarks are the property of their respective companies.

Table of Contents

Section 1: Introduction	1
Overview	1
Specifications	2
Key Features.....	4
Components.....	5
Accessories.....	7
Section 2: Setup and Test	9
Requirements.....	9
Steps	10
FlexSmart Modules	11
Launching the Logger	13
Checking Logger Status.....	14
Stopping the Logger.....	14
Reading out Data	15
Verifying Logger Operation	15
Section 3: Modules and Sensors	17
Adding and Removing Modules and Sensors.....	17
Smart Sensor Cables.....	17
Analog (CVIA) Module	18
Connecting Sensors to the Analog Module	19
Configuring Channels on the Analog Module	20
Verifying Operation	20
Sensor Excitation	20
Working with Channels	22
Section 4: Batteries and External Power.....	23
Selecting batteries	23

Battery Life	24
Maximizing Battery Life	25
Replacing Batteries.....	26
External Power Sources	28
Section 5: Maintenance	29
General Maintenance Schedule.....	29
Inspecting the Logger Housing and Cables.....	30
Verifying Sensor Accuracy.....	30
Cleaning the Logger.....	30
Section 6: Reference.....	31
Time Accuracy	31
Memory	33
Section 7: Diagnostics and Troubleshooting	34
Indicator LED behavior	34
Problems and Solutions	36
Index	39

Section 1: Introduction

This section discusses the following topics:

- Overview
- Specifications
- Key Features
- FlexSmart Modules
- Smart Sensors
- Components
- Accessories

Overview

The HOBO Energy Logger is a modular, reconfigurable data logging system used in energy and industrial monitoring applications.

The 15-channel system enables you to quickly and easily perform a broad range of monitoring applications. You can use the HOBO Energy Logger with FlexSmart™ modules, which convert signals from many types of Onset and third-party sensors. You can also use any Smart Sensor that is compatible with the HOBO Weather station or HOBO Micro Station.

Note: Although some Smart Sensors are intended mainly for outdoor use (for example, the Solar Radiation sensor), the Energy Logger is suitable for indoor use only.

Use HOBOWare® Pro software to configure and communicate with the logger. HOBOWare allows you to customize configuration settings, launch the logger, read out the data, and plot or export the data for analysis.

The Energy Logger package includes:

- HOBO Energy Logger
- Energy Logger User's Guide
- Eight 1.5V alkaline batteries
- One miniature slotted screwdriver
- Blank label
- Rubber feet

Specifications

Operating range	-20° to 50°C (-4° to 122°F) with alkaline batteries -40° to 60°C (-40° to 140°F) with lithium batteries
Sensor inputs	Three FlexSmart multi-channel modules and up to 6 Smart Sensors (which may have multiple parameters/channels)
Sensor connectors	Six RJ-12 Smart Sensor jacks plus 3 FlexSmart module slots
Communication	RS-232 via 3.5 mm serial port or/and 9-pin D-Sub connector
Dimensions	15.6 cm x 8.4 cm x 4.6 cm (6.13" x 3.31" x 1.81")
Weight	435 g (15.23 oz) with batteries 238 g (8.33 oz) without batteries
Memory	512K nonvolatile flash data storage
Memory modes	Stop when full; wrap when full
Operational indicators	Six indicators provide logging and sensor network status
Logging interval	One second to 18 hours, user-specified interval (2-second minimum for two-channel S-FS-TRMSA operation)
Sensor excitation	12 V DC at 200 mA total, with user-programmable warmup time on a per-channel basis
Battery life	One year typical use (up to 75 mA excitation with 10-minute or longer logging Interval and 1-second warmup time)

Battery type	Eight standard AA alkaline batteries included (for operating conditions -20°C/-4°F to 50°C/122°F); optional AA lithium batteries available for operating conditions of -40° to 60°C (-40° to 140°F).
External power	Supports optional 13.6 V DC regulated AC Wall Adapter Connector. Internal batteries may remain installed. Alternatively, an automotive battery or 9-12 V DC regulated Wall Adapter may be used, but it is recommended to remove the internal batteries since they will discharge to the level of the external supply.
Time accuracy	0 to 2 seconds for the first data point and ± 5 seconds per week at 25°C (77°F)
Logging mode	Immediate, timed delay, or trigger (button-push) start options; supports sampling intervals for some sensors
Data communication	Current readings while logging; read out while logging; read out when stopped
	CE marking identifies this product as complying with all relevant directives in the European Union (EU).

Key Features

Flexible expansion

The logger is not preconfigured. You can use any combination of FlexSmart modules (up to 3) and Smart Sensors (to a maximum of 15 channels) by plugging them in before logging begins.

Automatic detection of Smart Sensors

The logger automatically recognizes Smart Sensors. No programming, wiring, or calibration is required to set them up.

Digital network

The connections between the Smart Sensors and the logger are digital, ensuring accurate, reliable data collection and storage.

Excitation

The Analog module (S-FS-CVIA) supports optional, user-configurable sensor excitation power and warm up. The logger provides 12 V DC sensor excitation voltage up to 200 mA for transducers that require external power for proper operation. Refer to Sensor Excitation on page 20 for details.

Flexible power capabilities

The logger supports multiple battery types (alkaline, enhanced alkaline, or lithium) as well as several types of external power sources to allow for longer deployments while providing increased power for sensor excitation. Refer to External Power Sources on page 28 for details.

FlexSmart Modules

The logger is compatible with two types of FlexSmart modules, which can accommodate up to two sensors each. Up to three FlexSmart modules (in any combination) can be connected to the logger.

The **Analog Module** (S-FS-CVIA) offers configurable excitation power and can be connected to any one or two of the following sensors:

The **TRMS Module** (S-FS-TRMSA) can be connected to the following compatible AC current and potential (voltage) transformers:

For detailed information on these modules and sensors, including new modules and sensors that may have been introduced after this manual was printed, refer to the Onset website:

<http://www.onsetcomp.com/solutions/products/energy>

Smart Sensors

The Energy Logger can accommodate up to six Smart Sensors to monitor temperature, humidity, pressure, current, voltage, pulses, and other properties. Smart Sensors are automatically detected when logging begins, and do not require any configuration.

For detailed information on Smart Sensors, including new sensors that may have been introduced after this manual was printed, refer to the Onset website:

<http://www.onsetcomp.com/solutions/products>

Components

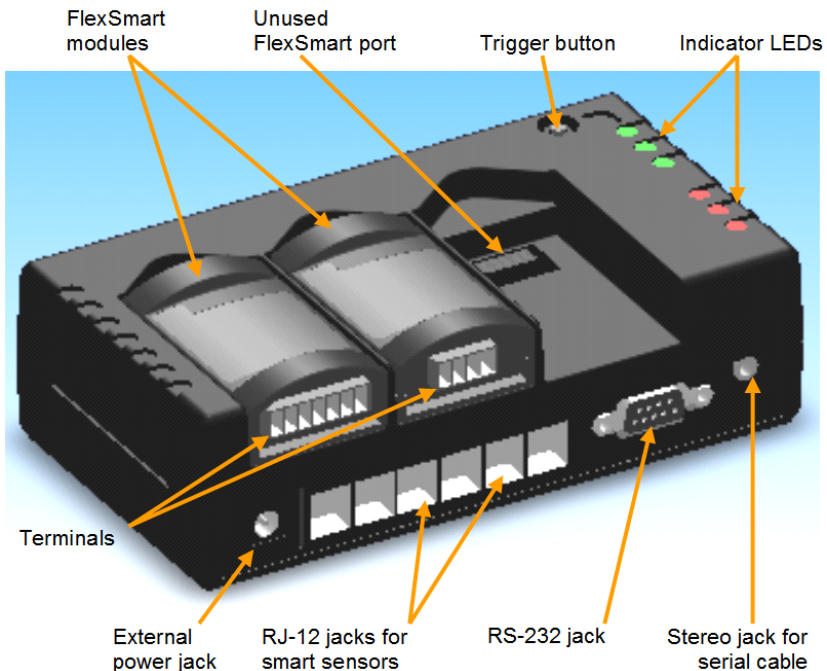

Figure 1: Components

FlexSmart Module Ports

Up to three FlexSmart modules can be installed on the logger. These can consist of any combination of Analog and TRMS modules. Third-party sensors (available through Onset) are connected to the logger through the terminals on these modules.

Trigger Button

Hold down the button for at least two seconds to manually start the logger in the field if the **Trigger** start option was selected in HOBOWare during launch.

Indicator LEDs

There are three green and three red status indicators. The green indicators blink to show status or activity. The red indicators blink to show that battery or memory is low, or that a sensor error has occurred. For more detailed description of the indicators, refer to Diagnostics and Troubleshooting on page 34.

Stereo Jack for Serial Cable

The serial interface cable is connected to this port to communicate with HOBOWare or the HOBO U-Shuttle.

RS-232 Jack

This port allows you to connect the logger via a DB9 connector instead of the stereo jack. The pinout for the logger's RS-232 connector is as follows:

Pin #	Function
1	DCD (Connected internally to 4)
2	RxD (Logger Received Data In)
3	TxD (Logger Transmit Out)
4	DTR (Connected internally to 1)
5	Signal Ground
6	NC
7	RTS (Connected internally to 8)
8	CTS (Connected internally to 7)
9	NC
Shell	Logger Chassis Ground

RJ-12 Jacks

Any combination of up to six Smart Sensors can be installed on the logger.

External Power Jack

An optional external power adapter can be connected to this port to power the logger.

Accessories

The following accessories can be used with the HOBO Energy Logger. These accessories can be purchased from an Onset Authorized Dealer, or directly from Onset Computer Corporation.

For detailed information on these accessories, including new items that may have been introduced after this manual was printed, refer to the Onset website: <http://www.onsetcomp.com/solutions/products/energy>

Accessory & Onset part #**Description**

USB Serial Adapter Cables ADAPT-SER-USB	Allows you to connect the logger to a USB port on your computer.
Energy Logger Feet A-H22-MOUNT-1	Allows you to securely mount the logger to a panel or other surface. Includes screws.
Energy Logger Mounting Kit A-H22-DINMOUNT-1	Allows you to mount the logger to industry-standard 32 mm and 35 mm DIN rails.
Energy Logger Spares Kit A-H22-SPARES	Spare bumpers, screwdriver, and FlexSmart module connector covers.
FlexSmart Analog Module Spares Kit A-FS-CVIA-7P	Four 7-pin screw terminals and screwdriver; lets you leave a sensor attached to screw terminal for later connection to module.

Accessory & Onset part #**Description**

FlexSmart TRMS Module Spares Kit A-FS-TRMSA-4P	Four 4-pin screw terminals and screwdriver; lets you leave a sensor attached to screw terminal for later connection to module.
Energy Logger AC Power Adapter P-AC-1	Allows you to power the logger using AC power, rather than batteries. (100 to 240 VAC, 50 or 60 Hz input.)

Section 2: Setup and Test

Before deploying the logger, read this section thoroughly and follow *all* of the procedures at least once. This will ensure that you are comfortable enough with the logger and with HOBOWare software to get the most out of your deployment. It will also verify that the logger is configured properly.

Note: Refer to the *HOBOWare User's Guide* for detailed information about setup.

Requirements

You will need the following items to prepare the logger for use:

- Eight 1.5V Alkaline Batteries and small Phillips head screwdriver (for battery door); or external power source
- At least one of the following:
 - FlexSmart modules with third-party sensors and miniature slotted screwdriver
 - Smart Sensors
- Serial interface cable (plus USB serial adapter if your computer does not have a serial port)
- Computer running HOBOWare version 2.1.1 or greater

Steps

To set up the logger, take the following steps:

1. Insert the batteries or connect external power source.

To install batteries, use a Phillips head screwdriver to loosen the screw on the back of the battery compartment door. Remove the door. Install eight fresh 1.5 V batteries, being careful to match the polarity marked in the battery compartment. (Refer to *Selecting Batteries* on page 23 for tips on selecting the right battery type for your application.) Replace the battery compartment door and tighten the screw to secure it. **Do not over-tighten the screw.**

See *Batteries* on page 23 for more information.

To use an external power source, plug the power adapter into an electrical outlet or other power source, then plug the power adapter into the external power jack. See *External Power Sources* on page 28.

2. Install FlexSmart modules (if applicable).

You can install up to three FlexSmart modules on the logger. Modules may be plugged into any slot in any combination. See *Installing FlexSmart Modules* on page 11.

3. Attach the third-party sensors to the modules (if applicable).

For information on installing the third-party sensors, refer to *Modules and Sensors* on page 17 as well as the instructions that came with the sensor.

4. Connect the Smart Sensors (if applicable).

Plug up to six Smart Sensors into the RJ-12 modular jacks, or use splitters to install more than six. (Keep in mind that some Smart Sensors have more than one sensor channel.) The logger supports up to 15 sensor channels, plus the logger's own battery channel (if selected for logging).

5. Connect to the host computer.

Use the serial interface cable (part # ADAPT-SER-USB) to connect the logger to a computer running HOBOWare. If your

computer does not have a serial port, you can use a Keyspan™ USB serial adapter (part # ADAPT-SER-USB) to connect the logger to a USB port on your computer.

6. Access the **Launch** dialog in HOBOWare.

In the Launch window, you should see a list of all the Smart Sensors and FlexSmart modules you connected to the logger.

Note: Modules and smart sensors are listed in HOBOWare in ascending order by serial number regardless of their physical position within the logger.

FlexSmart Modules

Installing FlexSmart Modules

Remove the protective cap from the module connector on the logger. Align the connector on the back of the FlexSmart module with the connector on the logger, and gently press the module into place.

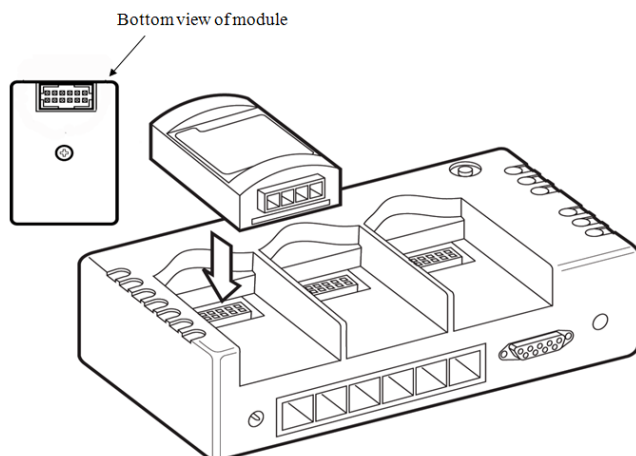

Figure 2: FlexSmart Module

Configuring FlexSmart Modules

While Smart Sensors are designed and preconfigured for specific purposes, FlexSmart modules are user-configurable to accommodate a wide range of Onset and third-party sensors. To take advantage of this adaptability, HOBOWare lets you configure these modules at launch time, or create and save different configurations to be loaded into the modules whenever needed.

If you connected only Smart Sensors, skip ahead to the next topic, “Launching the logger.”

1. Access the **Configure Channel** dialog in HOBOWare.

From the **Launch** window in HOBOWare, double-click a module name to expand it, then select a module channel and click **Configure**.

2. Load an existing configuration, if available.

HOBOWare may already have a default configuration for your sensor. Click the **Load** button to select an existing configuration for the sensor.

3. Review the loaded configuration, or create a new one.

The **Configure Channel** dialog allows you to create or change the channel name, scaling parameters, and other items. (Refer to the *HOBOWare User's Guide* for details.)

4. Review or set excitation power, if applicable.

If this is an Analog module, make sure that the excitation power settings are correct for the intended sensor.

5. Save the new or changed configuration.

Skip this step if you are using a default configuration without any changes.

6. Click **Configure** to complete the configuration.

Repeat these steps for each channel of each module.

Launching the Logger

Once all Smart Sensors have been connected and FlexSmart modules have been configured, access the Launch window in HOBOWare and take the following steps:

1. Select the correct battery type (alkaline or lithium).
If the battery type is not set correctly, the batteries will not report their power accurately.
2. Review the list of channels.
Make sure all of your sensors and modules are listed in the Launch window in HOBOWare. The FlexSmart modules and Smart Sensors are listed in ascending order by serial number. If more than 15 data channels are connected, the devices with the higher serial numbers will be ignored and their data will not be recorded. The logger can only record 15 data channels at a time.
3. Log battery voltage (Optional)
If you are using excitation power, you should also log the battery voltage. This channel does not count towards the 15-channel limit.
4. Wrap (Optional)
The Energy Logger will stop logging when its memory is full, or you can enable wrapping. With wrapping enabled, when the logger's memory fills up, the newest measurements will overwrite the oldest measurements.
5. Pre-set Data Assistants (Optional)
Configure pre-set Data Assistants as desired. See the *HOBOWare User's Guide* for details.
6. Review other launch settings.
Select logging and sampling intervals, and indicate whether you want to begin logging now, wait for a timed delay, or a trigger start. Refer to the *HOBOWare User's Guide* for more information about these settings.
7. Click **Launch**.

Depending on the option you select, the logger may start automatically (either immediately or at a specified time), or you may start it manually by pressing the **Push to Start** button on the logger.

Checking Logger Status

You can verify logger status by looking at the indicator lights on the logger. The LEDs blink to let you know if the logger is waiting for a delayed or button start, or if the logger is already logging. Other LEDs blink to warn you when battery power or memory is running low, or if there is a sensor error. Refer to Indicator LED Behavior on page 34 for details.

You can get more detailed information about battery power, sensor readings, and memory in HOBOWare at any time, whether the logger is logging or not. Refer to the *HOBOWare User's Guide* for details about the Status window.

Note: In HOBOWare, battery capacity is reported differently depending on the type of batteries being used. For alkaline batteries, the status is displayed as a percentage of the capacity remaining.

For lithium batteries, capacity is listed as “Good” for 25-100% capacity remaining, or “Empty” for 25% or less capacity remaining. This is necessary because lithium battery voltage does not vary much until the batteries are nearly depleted. Because of the uncertainty in capacity, you may wish to start each deployment with fresh lithium batteries that you know are at 100%, rather than rely on old ones.

Stopping the Logger

If wrap is not enabled, the logger automatically stops recording data when the memory is full. You can also stop the logger manually at any time by using the **Stop** command in HOBOWare.

Once the logger has stopped, the data remains in the logger until the next launch.

Reading out Data

Use HOBOWare to read out data from the logger. Reading out copies data from the logger to your computer, allowing you to save the data in a .dtf file and view the plot.

You can read out while the logger is recording data, or after the logger has been stopped. Refer to the *HOBOWare User's Guide* for details about reading out, saving, and displaying data.

Verifying Logger Operation

It is a good idea to quickly test the logger before each deployment, especially if the logger has been stored unused for a long period. To test the logger, take the following steps:

1. Set up the logger (attach sensors, etc.) and start HOBOWare.
2. Access the Launch window and verify that HOBOWare detects all of the connected modules and sensors.
3. Enter a logging interval of a few seconds so that your test will yield enough data to look at, and select the logger's internal battery channel. Make sure the logger is configured to start logging immediately upon launch.

Important: If you are using both channels of a TRMS module, you must select a minimum 2-second logging interval. If all TRMS modules are configured for single-channel use, you can use a 1-second logging interval.
4. If you are using sensor excitation, configure it for each FlexSmart Analog module channel. Sensors purchased from Onset include sensor connection instructions, including warmup time (if required). For sensors not supplied by Onset, consult the sensor manufacturer's datasheet for warm up time requirements.
 - Many sensors specifications assume that the sensor will be powered continuously, but may be capable of switched operation to conserve battery life. You may need to experiment to determine the best warm up time for rated transducer accuracy.
 - The Energy Logger disables excitation when the battery pack voltage falls to approximately 6.8V (0.85 volts per cell). The

batteries are essentially dead at this point and should be changed. The logger will continue to log, but data for channels using excitation will be invalid.

5. Click **Launch** to start the logger.
6. After a couple of minutes, read out the logger. (Answer **Yes** when prompted to stop the logger.)
7. Make sure the data appears normal for all sensors.

Section 3: Modules and Sensors

This section provides details on working with modules and sensors.

Adding and Removing Modules and Sensors

Whenever possible, it is best to add and remove modules and sensors between deployments – after stopping the logger and reading out data, but before relaunching. However, circumstances may require that you add or remove a module or sensor at some other time.

If you **add** a module or sensor while the logger is recording data, the module or sensor will be ignored. Logging will continue normally for the other channels.

You may attach modules and sensors at the following times:

- Any time between deployments, when the logger is stopped.
- While you are configuring the launch parameters in HOBOWare. Click **Refresh** to update the **Logging Duration** and see the new module or sensor added to the list of sensors.
- After you have launched the logger, but before logging has begun (i.e. when the logger is waiting for a delayed or button start). Note that adding modules or sensors will cause the logging duration to be shorter than the duration that was displayed in the Launch window.

If you **remove** a module or sensor while the logger is logging, the **Sensor Fail** indicator will blink when the next logging interval is reached, and the logger will record erroneous data for that channel. This is true even if you immediately connect another sensor of the same type in the same port. If you want to change sensors – even sensors of the same type – you must stop the logger, read it out, swap the sensors, and then relaunch.

Smart Sensor Cables

The logger can work with a maximum total of Smart Sensor cable lengths up to 100 meters (328 feet), as measured from the logger connection point to the electronics embedded in the individual cables. Optional Smart Sensor extension cable lengths must also be included in the total.

This limitation applies to Smart Sensor cables only. The lengths of other cables, such as those connected to FlexSmart modules, do not need to be included in this total.

Analog (CVIA) Module

The Analog module (S-FS-CVIA) is an easy-to-configure, flexible DC signal-conditioning module for the HOBOWare Energy Logger. This two-channel module can accept (and provide excitation power to) a wide range of Onset and third-party sensors with 0-0 V or 0-20 mA output, including devices with 4-20 mA current loop interface, and sensors with 0-2.5, 0-5, and 0-10 V DC output.

The Analog module features input protection and signal filtering, as well as delta-sigma A/D conversion and factory calibration. This module features extremely low-power operation, resulting in long battery life for unattended data logging applications. Precision electronics provide $\pm 0.25\%$ accuracy from 50 mV to full scale (FS).

Sensors connected to this Analog module can be configured in HOBOWare software. Configuration options include channel names, scaling parameters, and excitation power. Sensors are connected to the module via a seven-pin Phoenix-style detachable screw terminal connector.

Functional Block Diagram

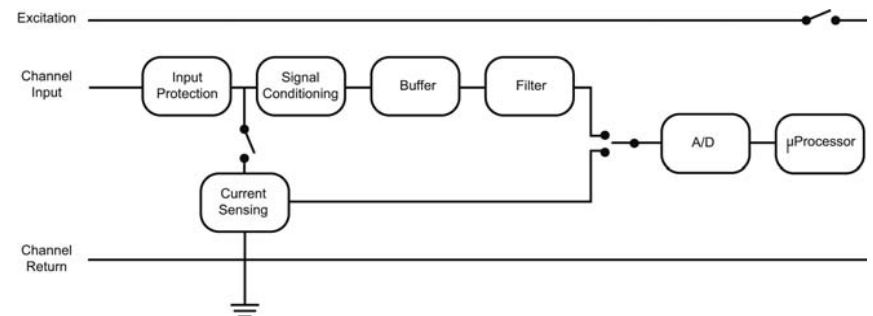

Figure 3: Analog Module - Functional Block Diagram

Connecting Sensors to the Analog Module

Insert the Phoenix-style screw terminal connector into the connector on the end of the module.

Note: The Analog module is a single-ended device. Pins 3 and 7 are connected to signal ground and to each other.

Refer to the sensor documentation for terminal connection details and use the pinout diagram below to connect a two- or three-wire sensor or transducer to the module's terminals. To make the connection, loosen the screw for each pin on the connector, insert the appropriate wire, and tighten the screw.

The following example illustrates typical connections for a voltage sensor, and a current sensor that requires excitation:

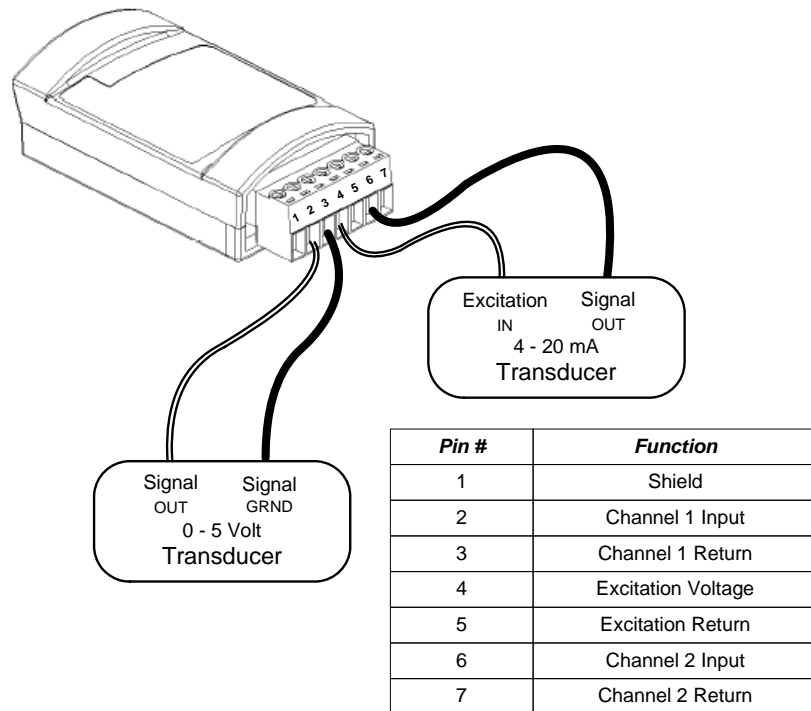

Figure 4: Voltage Sensor Connections

Tip: Always refer to your sensor documentation for terminal connection details.

Once the sensors are connected, install the Analog module into any of the three module slots on the logger.

Use the provided label to identify a module/sensor combination to aid in determining sensor placement and cable routing when in the field.

Configuring Channels on the Analog Module

Each channel of the Analog module is individually configurable to accept a wide range of sensors. That means that each channel can be configured to measure either current or voltage, and the collected data can be scaled to produce meaningful results that are consistent with the properties being measured.

Use HOBOWare to configure each channel at launch time, or create and save different configurations to be loaded into the modules whenever needed. A channel configuration consists of a channel name, measured property name, scaling parameters, and excitation information, if applicable. Refer to the *HOBOWare User's Guide* for details.

Verifying Operation

When logging begins, the logger will acquire and store measurements from the sensors attached to the module. When the module is functioning correctly, the **Active** indicator on the module blinks once per logging interval for each configured channel to indicate that a successful measurement has been made.

Sensor Excitation

Sensor excitation is a voltage output provided by the logger to power a sensor that is connected to it. This power may be needed because the sensor is not self-powered, or because the sensor's power capacity cannot support a long deployment.

When sensor excitation is required, the logger can provide 12 V DC sensor excitation voltage up to 200 mA total for transducers that require external power for proper operation. The excitation voltage has a programmable warm up time and is controlled by the FlexSmart Analog module. Excitation is controlled on a per-module basis.

Excitation power can drastically reduce logger battery life. If your sensor does not require it, you should not include it in the channel configuration.

If you do need to use it, carefully select the sensor excitation mode that best meets your needs. Two modes are available:

- **Warm up mode** – The logger supplies excitation power for a brief, user-programmable period prior to each measurement. This mode allows you to select the minimum warm up time needed to allow for sensor stabilization, while conserving the logger’s battery power. For example, if you specify a warm up time of one second and set the **Logging Interval** in the logger to one minute, the logger will power the external sensor for one second, log a measurement, and then turn off the excitation power for the next 59 seconds. The warm up time can be up to 120 seconds.

Note: If the warm up time selected is greater than the logging interval selected, the logger will interpret the excitation mode as continuous.

- **Continuous mode** – The logger supplies constant excitation power to the sensor for the entire duration of the deployment. This mode will result in the shortest battery life. Continuous mode is required if the sensor needs more than two minutes of warm up time. If you need to provide continuous excitation to a sensor, you should consider backing up your batteries with an external power source. Refer to External Power Sources on page 28 for details.

Important: When using excitation power, always enable the logger’s internal battery channel at launch. If the battery becomes too low to provide excitation power, excitation power is turned off, but logging continues as long as the battery can power the logger. This will cause the further readings on that channel to become inaccurate. If you are logging the internal battery channel when this happens, an “Excitation Off” event will be shown in your datafile to mark the point at which excitation power was disabled. (If you do not log the internal battery channel, you will not have anything in your datafile to identify the point beyond which the data might be inaccurate.)

Working with Channels

The Energy Logger can log up to 15 data channels (not including the internal battery channel). This includes all FlexSmart module channels, plus each of the Smart Sensor channels (note that some Smart Sensors may have more than one channel). If you have more than 15 channels connected, some of the sensors will be ignored. You should remove any Smart Sensors that will not be used in the deployment, and disable any module channels that are not needed.

- FlexSmart modules have two channels. If you want to log only one channel, you can disable the unused channel on the Launch window in HOBOWare. Refer to the *HOBOWare User’s Guide* for details.
- If you connect a Smart Sensor that has multiple channels (such as temperature and relative humidity), all of its channels will be logged. There is no way to disable them.

Section 4: Batteries and External Power

The HOBO Energy Logger requires eight 1.5V AA batteries. The logger is shipped with eight alkaline batteries, and is also compatible with enhanced alkaline batteries and lithium batteries (Li/FeS₂).

An external power source can reduce or eliminate the need for internal batteries in applications that have readily available AC power, or require more current and/or longer deployments than the logger's internal batteries can support. See External Power Sources on page 28.

Selecting batteries

Onset recommends alkaline batteries for most applications because they are inexpensive, can provide more accurate battery status readings in HOBOWare, and last longer than similar lithium batteries at moderate temperatures.

However, some applications or environments are better suited to other types of batteries. Refer to the following table to determine which type of battery you should use.

Battery type	Considerations for use
Alkaline	<p>These are best for most applications at moderate temperatures.</p> <p>Alkaline batteries also work in temperatures ranging from 40° to 50°C (104° to 122°F) and from -20° to 0°C (-4° to 32°F), but may not perform as well as lithium batteries at these temperatures.</p> <p>At temperatures lower than -20°C (-4° F) and higher than 50°C (122°F), alkaline batteries are not suitable. Use lithium batteries instead.</p>
Enhanced alkaline (such as Energizer® E2 or Duracell® Ultra)	<p>Consider these for applications with higher sensor excitation requirements and moderate temperatures. These batteries are specifically designed for high-current use. For low-current applications, however, they offer little improvement.</p>

Battery type	Considerations for use
Lithium (Li/FeS ₂)	<p>Lithium batteries last longer than alkaline batteries in applications with extreme or varying temperatures (below 0°C/32°F or above 40°C/104°F). They also outperform alkalines in deployments with high sensor excitation currents (>100 mA) or long warmup times.</p> <p>Lithium battery voltage does not vary much until the batteries are nearly depleted. Because of the uncertainty in capacity, you may wish to start each deployment with fresh lithium batteries that you know are at 100%, rather than rely on old ones.</p>

Important: Do not use any other type of battery, such as carbon zinc (“heavy duty”) or rechargeable batteries. These batteries will not perform well and will not report their battery status accurately in HOBOWare.



WARNING: Fire, Explosion, and Severe Burn Hazard. Do not mix battery types, either by chemistry or age; batteries may rupture or explode. When replacing the batteries, read and follow their disposal instructions; dispose of lithium batteries according to local regulations. Do not dispose of batteries in fire. Never attempt to recharge a lithium or alkaline battery. Do not heat the batteries above 185°F (85°C). Do not mutilate or rupture the battery housing. Lithium batteries may explode if the logger is exposed to extreme heat or conditions that could damage or destroy the battery case. Do not expose the contents of the battery to water.

Battery Life

Battery life will vary with the following factors:

- Sensor excitation current and warm up time (most important factor)
- Logging interval (and sampling interval, if applicable) selected
- Number of sensors being used

- Battery type
- Operating environment (e.g., temperature)

The following graph can help you estimate how long batteries will last (the run time) at different logging intervals and excitation currents with a warm up time of 30 seconds.

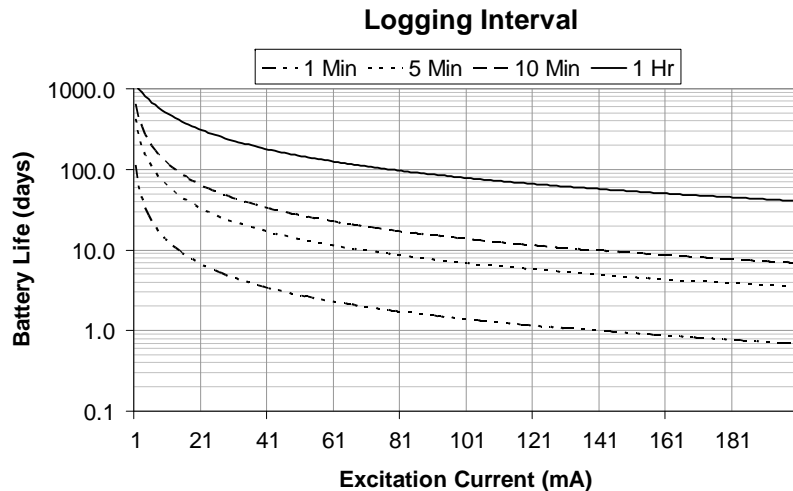

Figure 5: Battery Life

Note: This graph assumes that standard alkaline batteries and three FlexSmart modules are being used.

This graph was generated from a spreadsheet that can estimate battery life for varying parameters. Contact Onset Technical Support for more information.

Maximizing Battery Life

- Batteries are inexpensive compared to the cost of a new logger or a missed logging opportunity. If you suspect that batteries are damaged or run down, replace them immediately to prevent leakage or logger malfunction.
- When launching the logger in HOBOWare, do not set a **Sampling Interval** unless you have sensors that support measurement averaging. Only the following Smart Sensors and input adapters support measurement averaging:

- 12-bit Temperature S-TMB-M0XX
- 12-bit 4-20 mA Input Adapter (S-CIA-CM14)
- 12-bit Voltage Input Adapter (S-VIA-CM14)
- Photosynthetically Active Radiation (PAR) S-LIA-M003
- Silicon Pyranometer (Solar Radiation) S-LIB-M003

Note: Although some Smart Sensors are intended mainly for outdoor use (for example, the PAR and Solar Radiation sensors), the Energy Logger is suitable for indoor use only.

- If you are using excitation voltage, select the shortest warm up time needed for the sensor.
- Verify that the batteries' "Use Before" date is at least two years from the current date.
- Alkaline batteries will lose up to 10% of capacity per year if they are sitting on a hot shelf. They can lose 50% or more of their capacity if exposed to heat repeatedly (for example, stored on a car dashboard). Keeping batteries in the refrigerator can reduce self-discharge to 1 to 2% per year, but you must prevent condensation from forming on the batteries.
- Use new batteries if you expect the deployment to require a substantial portion of battery life.

Replacing Batteries

Fresh batteries are cheap insurance for extended deployments or high-draw applications when using an external power source is not feasible.

- Before replacing batteries, always read out the logger to prevent data loss.
- Replace batteries at least once a year to prevent loss of data.
- Replace batteries more often if you are using sensor excitation.

To replace batteries:

1. Select the type of batteries you will use and obtain eight fresh, new batteries of the same type. For more information on

selecting the type of batteries to use for your application, refer to Selecting batteries on page 23.

- Using a Phillips head screwdriver, loosen the screw on the back of the battery compartment door. Remove the door.

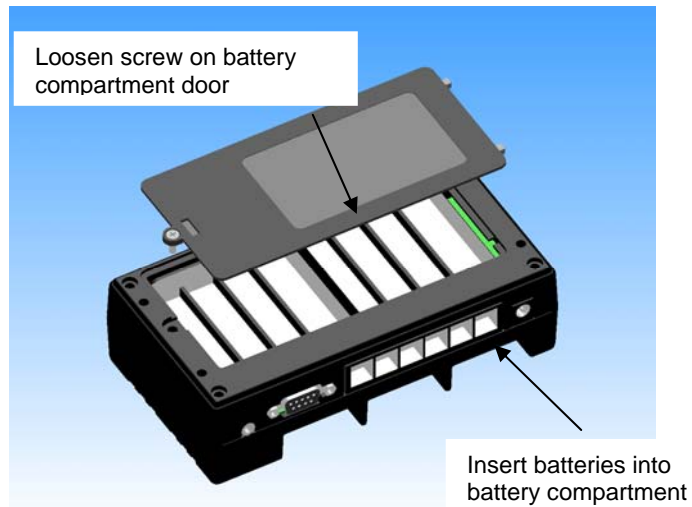

Figure 6: Replacing Batteries

- Remove the used batteries and dispose of them properly.
- Install eight new 1.5 V AA batteries, using care to match the polarity marked in the battery compartment. **Do not mix battery types.**
- Position the battery compartment door in place and tighten the screw to secure it. **Do not over-tighten the screw.**

Recovering Data from a Logger with Dead Batteries

The logger uses very durable, high-capacity Flash memory. With this memory, data is retained even when the batteries are dead or removed.

If the logger stops recording data because the batteries are dead, you can recover the data that has been recorded. Simply replace the batteries and then read out the data from the logger as usual.

Important: Do not relaunch the logger until the data has been recovered. If, after changing the batteries, you are still unable to read out your

logger, contact the vendor that sold it to you. It may be possible to retrieve the logged data.

External Power Sources

An external power source can reduce or eliminate the need for internal batteries in applications that have readily available AC power, or require more current and/or longer deployments than the logger's internal batteries can support. The logger can operate on a DC input voltage from several external sources including:

- Standard 12 V automotive/motorcycle type battery
- Sealed lead-acid (SLA) type 12 V battery (used in uninterruptible power supplies and emergency lighting systems)
- External alkaline/lithium battery packs
- Optional AC power adapter (Onset part # P-AC-1)

There are two ways you can use an external power source:

- Battery eliminator mode** - In place of the internal batteries. In this mode, the logger can operate on a DC input voltage ranging 8 V – 15 V.
- Battery backup mode** - To conserve the internal batteries as an automatic back-up supply if the external supply should fail, similar to an uninterruptible power supply. To do this, you must provide a DC input voltage **greater than** that of the internal batteries. Thus, a DC input voltage of 13.6 V – 15 V is required for proper operation.

External Power Adapter Specifications

- Able to deliver 750mA
- Positive outer sleeve
- 2.1 mm center pin diameter
- 5.5 mm outer sleeve diameter
- 10 mm outer sleeve length

Section 5: Maintenance

This section describes general maintenance activities for the HOBO Energy Logger.

General Maintenance Schedule

Regular maintenance of the logger is essential to ensure the accuracy of recorded measurements. The logger is primarily intended for indoor use. It can be damaged by many environmental conditions, such as moisture, airborne contaminants, vibration, and tampering. Performing regular maintenance checks allow you to:

- Verify that the logger is logging data and functioning as you expect
- Identify damage
- Minimize the impact of any existing damage

The following table lists maintenance activities and how often they should be performed:

Activity	Frequency
Inspect logger housing and cables	Each use.
Verify sensor accuracy	Refer to the sensor manufacturer's manual for information on how often to verify sensor accuracy.
Clean the logger	As needed.
Replace the batteries	At least once a year, or before any deployment that requires many sensors, excitation, etc. or is scheduled for an extended deployment.
Verify logger operation	Before each deployment.

Inspecting the Logger Housing and Cables

Periodically perform a visual inspection of the logger. Verify that the logger housing is free of visible damage, such as cracks, and that it is clean.

Also ensure that cables and wires are free of damage, such as cracks, cuts, and splits; are fastened securely, free of corrosion and in good condition.

Verifying Sensor Accuracy

Onset recommends that you test most Smart Sensor accuracies once a year. For details on verifying sensor accuracy, refer to the documentation included with each sensor. For third-party sensors (even those supplied by Onset), refer to documentation provided by manufacturer.

For a fee, Onset can verify the accuracy of any sensor. It may be possible to recalibrate some sensors. Contact Onset Technical Support for details.

Cleaning the Logger

The logger does not require specialized cleaning; however, if it is deployed in a dusty or grimy location, you should wipe it down with a damp cloth occasionally. This will prevent dirt from interfering with sensors.

Section 6: Reference

Time Accuracy

When you launch a logger, its clock is set by the host computer's time and time zone offset from UTC. (UTC, or Coordinated Universal Time, is similar to Greenwich Mean Time.) The time zone offset makes it possible to determine objective, non-local time. This prevents conflicts and confusion when you relaunch a logger with a shuttle that may have been launched in a different time zone, or before a Spring or Fall time change.

Once the logger is logging, it will keep fairly accurate time. However, the following may cause errors with time reporting.

- **Host clock error.** The most likely source of error is an incorrect time, or time zone setting, on the computer that launched the logger. Make sure the clock on your computer is set to the correct date and time before launching the logger. One accurate resource is <http://www.nist.time.gov>.
- **Launch time loss.** The logger may lose up to two seconds when it is launched. This is a one-time error that occurs as part of the start-up sequence and cannot be avoided.
- **Clock drift.** The logger's long-term time accuracy is related to ambient temperature. At 25°C (77°F), the worst-case error is ± 8 parts per million (PPM), or about 5 seconds per week. The error increases as the temperature deviates from 25°C, as shown in the graph below. At a constant temperature of -20°C, the logger time error could be as much as 35 PPM (21 seconds per week).

The following graph shows the worst-case time error.

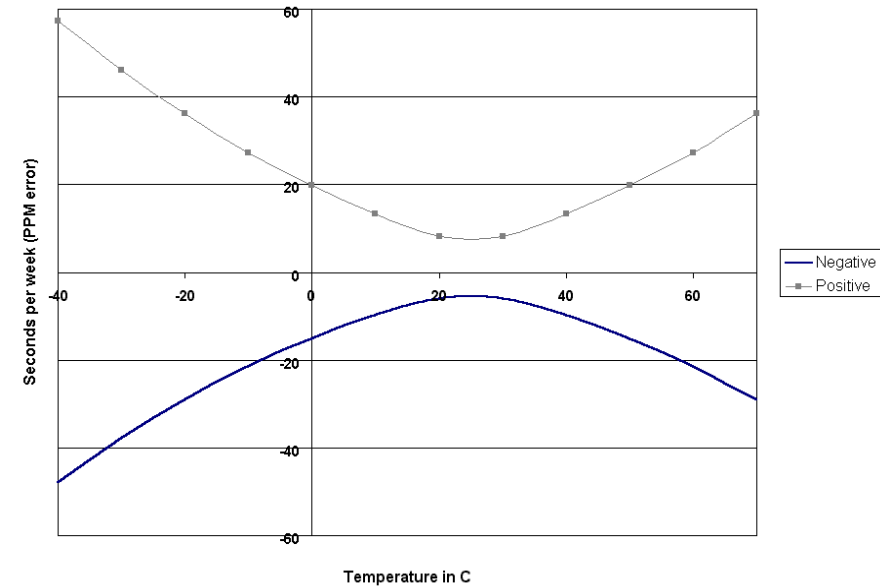

Figure 7: Worst-case Time Error

Resetting the Logger's Clock

Reading out the logger and relaunching it will reset the logger's clock. This is useful when your logger has been running for a while and its clock needs to be reset. Make sure the computer clock is set accurately before relaunching.

1. Exit HOBOWare.
2. Correct the computer's clock.
3. Restart HOBOWare.
4. Read out the logger, if you have not done so already.
5. Relaunch the logger.

Memory

The logger contains 512K bytes of very durable, high-capacity, non-volatile Flash memory, which stores data even if power runs out. This allows for data retention even when the batteries become depleted or are removed.

Up to 10K of this memory is used to store the launch configuration and deployment notes, leaving at least 502K bytes for data storage. HOBOWare automatically estimates how long the logger will record data before the memory fills up, based on the logging interval and the number and type of sensors connected. This is called the **logging duration**.

Adding sensors or logging the internal battery channel decreases the logging duration; increasing the logging interval increases the logging duration.

For most applications, it is battery life and not memory capacity that limits the logging duration. The following table shows the expected run time for several logging intervals based on the total number of bits in place, which is determined by adding together the bits per sample for each sensor measurement parameter in your system. For example, a HOBO Energy Logger with the following sensors is using 56 total bits.

Sensor		Bits per Sample		Total bits
1 temperature sensor	X	8	=	8
1 wind speed sensor	X	16	=	16
2 temperature sensors	X	16	=	32
Total number of bits				56

At a logging interval of 5 minutes, the logging duration for a logger using 56 bits would be approximately 250 days. (Refer to the sensor manual to determine the number of bits each type of sensor uses.)

Section 7: Diagnostics and Troubleshooting

This section lists some symptoms and tips to help you confirm correct operation of your logger, and help you diagnose possible problems. It discusses the following diagnostic and troubleshooting topics:

- Indicator LED behavior
- Testing the logger
- Problems and solutions

Indicator LED behavior

The indicator LEDs can provide helpful clues as to what the logger is doing, especially when it is not behaving as expected.

Note: The indicators are very faint under direct sunlight or bright fluorescent lighting. If no indicators appear to be blinking, shield the logger from the light and check the indicators again.

Push to Start (Green)

If you have launched the logger with the **Trigger** start option, this indicator will continue blinking and will not record any measurements until you press and hold the **Push to Start** button on the logger for at least two seconds. You can add and remove Smart Sensors and FlexSmart modules while this indicator is blinking.

Delayed Start (Green)

If you have launched the logger with an **At Interval** or **Delayed** start option, the indicator will continue blinking and the logger will not record measurements until the defined start date/time. You can add and remove Smart Sensors and FlexSmart modules while this indicator is blinking.

Logging (Green)

This indicator blinks every two seconds while the logger is recording data from sensors. Sensors must not be added while this indicator is blinking.

If this indicator is not blinking when you believe it should, make sure the logger has been launched. If you configured the logger to launch with a

delayed or interval start, check the date and time you selected and make sure the **Delayed Start** indicator is blinking. If you configured the logger to launch with the **Trigger** start option, press and hold the **Push to Start** button on the logger until all the indicators flash at once (at least two seconds).

Memory Low (Red)

If the logger was launched with wrapping disabled, this indicator blinks when less than 25% of memory remains for saving data. The logger will continue to run until all memory is used.

If the logger was launched with wrapping enabled, this indicator should not blink.

Battery Low (Red)

This indicator blinks when battery power is at less than 25% capacity, or if the batteries are installed improperly. The logger will continue logging until the batteries are dead; however, you should read out the data and replace the batteries as soon as possible, before the batteries die, and then relaunch the logger. Or, attach an external power source if possible.

If this indicator continues to blink even after you have replaced the batteries:

- Check that the batteries are installed properly. If the polarity of any of the batteries is incorrect, this indicator will blink.
- Make sure you are using the correct battery type. The logger uses eight 1.5 volt AA alkaline or lithium batteries. The battery type must be specified correctly on the Launch Logger dialog for the correct battery status to be reported.
- Make sure all batteries are of the same type - either all alkaline, all enhanced alkaline, or all lithium. Never mix battery types.
- Check the battery expiration date. Verify that the expiration date is at least two years from the current date. Batteries can lose significant capacity if stored at elevated temperatures.
- Check the voltage of the batteries with a voltmeter. Alkaline batteries should be at least 1.5 V per cell when new; fresh lithium batteries should be 1.6 V per cell.

Sensor Fail (Red)

This indicator blinks when there is or has been a FlexSmart module or Smart Sensor communication failure.

Note: If the **Sensor Fail** indicator is blinking, you should read out the logger, investigate the problem, and then relaunch the logger.

- If the **Sensor Fail** indicator is blinking in conjunction with the **Logging** indicator, there was a communication failure, but the system has recovered. There may be an intermittent problem. Try checking the FlexSmart modules and Smart Sensors one at a time to make sure they are all communicating. If you find a bad module or sensor, or if no module or sensor communicates, contact your Onset Authorized Dealer or Onset Technical Support.
- If the **Sensor Fail** indicator is the only one that is blinking, at least one FlexSmart module or Smart Sensor is currently not communicating. You should investigate this problem immediately. Look for a loose connection, which could cause bad electrical contact with a module or sensor. If found, remove the offending module or sensor and check its wires and connector for damage and/or signs of moisture.

Problems and Solutions

Problem	Solution
No status indicators are blinking	<p>The indicators are very faint under direct sunlight or bright fluorescent lighting. If no indicators appear to be blinking, shield the logger from the light and check the indicators again.</p> <p>Check the status in HOBOWare:</p> <ul style="list-style-type: none"> • Make sure the batteries are not dead. Batteries should have at least 1 volt per cell. • The memory may be full. Read out the logger and relaunch. • The logger may not have been launched.

Problem	Solution
Individual modules or sensors are not found, or are missing in HOBOWare's Launch Logger dialog	<p>If a FlexSmart module or Smart Sensor is removed and then immediately reconnected, it may not be detected, and therefore will not appear on the Launch Logger dialog. Click the Refresh button on the Launch Logger dialog.</p> <p>Check for a loose connection between the module or sensor and the logger.</p> <p>Make sure you have not exceeded 100 meters (328 ft) of network cable for all Smart Sensors.</p>
No modules or sensors appear in HOBOWare's Launch Logger dialog	Remove all modules and sensors except one, click Refresh , and see if the module or sensor appears on the Launch Logger dialog. Continue to remove and reconnect modules and sensors one at a time until you identify the culprit. If you find the bad module or sensor, or if none of the modules or sensors communicates, contact your Onset Authorized Dealer or Onset Technical Support.
Batteries die prematurely	<p>Check for excessive moisture or contamination in the logger enclosure. Severe and/or repeated condensation in the logger enclosure can lead to short circuits and battery failure. It may be necessary to place the logger in an additional weatherproof case with desiccant inside the enclosure to prevent condensation.</p> <p>Make sure that both the logging and sampling intervals are set for at least one minute or greater. Fast sampling and logging intervals (shorter than one minute) will rapidly deplete the battery. For more information, refer to "Maximizing battery life" on p. 25.</p> <p>Check for damaged wiring and malfunctioning modules and sensors. Damaged cables or connectors can result in complete or partial short circuits that will rapidly drain batteries.</p>

Problem	Solution
Datafile contains errors	If you are missing data for a particular module or sensor, check that it was properly installed and configured. Remove and reconnect the module or sensor, and check the status in HOBOWare to verify that it can report accurate readings. If you find that it is not communicating, it may be damaged. Contact your Onset Authorized Dealer or Onset Technical Support.
Excitation power stops working	The batteries have dwindled to 6.8 V while excitation was in use. The batteries are nearly dead and must be changed.
Datafile cannot be opened	In rare circumstances, the datafile may have become corrupted. Read out the logger again and try opening the file again. If that does not work, contact your Onset Authorized Dealer or Onset Technical Support.
Logger is not found	<p>Check and replace the batteries, and reconnect the logger.</p> <p>Check communication cable connections.</p> <p>Review the Communication preferences in HOBOWare.</p> <p>Check the computer's COM port/USB settings.</p>

Index

- Analog module, 4, 7, 12, 15, 18–20, 20
- Batteries, 3, 4, 13, 14, 23–26
 dead, 16, 27, 33, 37
 indicator, 35
 installing, 10
 replacing, 26
- Battery channel, 10, 13, 15, 21, 22, 33
- Delayed/interval start, 3, 13, 17, 34, 35
- Excitation, 2, 4, 12, 13, 15, 18, 19, 20–21, 23, 24, 38
- External power source, 3, 4, 7, 8, 10, 21, 28, 35
- FlexSmart modules, 2, 12, 13, 22
 analog, 4, 7, 12, 15, 18–20, 20
 TRMS, 2, 4, 8, 15
- Indicators (LEDs), 2, 14, 17, 20, 34–36, 36
- Logging interval, 2, 15, 17, 20, 21, 24, 33, 37
- Measurement averaging. *See* Sampling interval
- Memory, 2, 14, 27, 33, 36
 wrapping, 13, 14, 35
- Power adapter, power supply.
see External power source
- Sampling interval, 3, 13, 24, 25, 37
- Sensor excitation. *See* Excitation
- Sensors, 2, 36, 37
 adding and removing, 17
 FlexSmart, 4, 10, 12, 13, 19, 22, 34
 Smart, 1, 4, 5, 10, 13, 17, 22, 25, 26, 30, 34
- Smart Sensors, 1, 2, 4, 5, 10, 13, 22, 25, 26, 30, 34
 cable lengths, 37
 cable lengths, 17
- Trigger (button) start, 3, 6, 13, 14, 17, 34, 35
- TRMS module, 2, 4, 8, 15
- Warmup, 2, 15, 21, 24, 26
- Wrap, 2, 13, 14, 35

Onset Computer Corporation
 470 MacArthur Blvd.
 Bourne, MA 02532