

## Ultrasonic Sensor Model PZ34

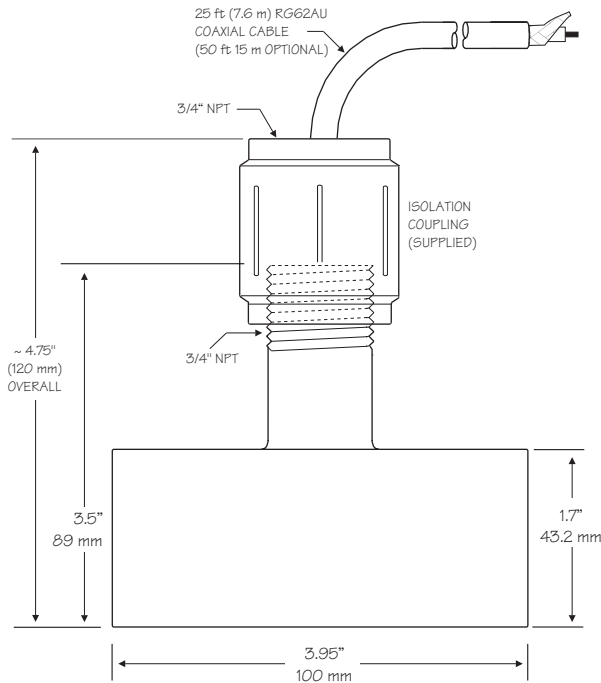

### General Specifications

Maximum Range:	32 ft. (10 m)
Minimum Range (Deadband):	16" (406.4 mm)
Operating Frequency:	46 KHz
Beam Angle:	8°
Operating Temperature:	-40° to 150° F (-40° to 65° C)
Maximum Operating Pressure:	20 psi (1.35 bar)
Exposed Materials:	PVC
Sensor Mounting:	3/4" NPT
Maximum Cable Length:	500 ft (150 m)
Optional Hazardous Rating:	CSA rated Intrinsically Safe Class I, Groups C,D, Class II, Groups E,F,G with optional Intrinsic Safety Barrier. Note: Max Range reduced to 25 ft. (7.8 m) with ISB option.

### Notes:

1. Shield from direct sunlight (temperature probe in sensor)
2. Use the "Isolation Coupling" supplied for mounting.
3. Use with Option ISB Intrinsic Safety Barrier for installation in hazardous locations.
4. Run Sensor cable in grounded metal conduit with no other conductors.
5. Extend Sensor cable up to 500 ft (152 m) with RG62AU coaxial only.
6. Refer to the Instruction Manual for complete installation and wiring instructions.

### Recommended Sensor Mounting

