



INSTRUMENTS

GX-6000
Single Sensor PID Model
Operator's Manual

Part Number: 71-0363

Revision: H

Released: 6/27/19

WARNING

Read and understand this instruction manual before operating instrument. Improper use of the gas monitor could result in bodily harm or death.

Periodic calibration and maintenance of the gas monitor is essential for proper operation and correct readings. Please calibrate and maintain this instrument regularly! Frequency of calibration depends upon the type of use you have and the sensor types. Typical calibration frequencies for most applications are between 1 and 3 months, but can be required more often or less often based on your usage.

Table of Contents

Chapter 1: Introduction	8
Overview	8
About the GX-6000	8
Specifications	9
About this Manual	10
Chapter 2: Description	11
Overview	11
Instrument Description	11
<i>Case</i>	11
<i>LCD</i>	11
<i>Control Buttons</i>	12
<i>Flashlight LED</i>	12
<i>Alarm LEDs</i>	12
<i>Infrared Communications Port</i>	12
<i>Buzzer</i>	12
<i>Vibrator</i>	13
<i>Printed Circuit Boards (PCBs)</i>	13
<i>Pump</i>	13
<i>Flow Chamber</i>	13
<i>Sensors</i>	13
<i>Inlet Filter Holder</i>	14
<i>Batteries</i>	14
Included Accessories	14
<i>Tapered Rubber Nozzle</i>	14
<i>Belt Clip</i>	14
<i>Rubber Boot</i>	15
<i>Wrist Strap</i>	15
<i>Sample Hose and Probe</i>	15
<i>Screen Protector</i>	15
Other Accessories	16
<i>VOC Zero Filter</i>	16
<i>DIN Rail Mounting Assembly</i>	17
Chapter 3: Operation	20
Overview	20
Start Up	20
<i>Turning On the GX-6000</i>	20
<i>Performing a Demand Zero</i>	28
<i>Turning Off the GX-6000</i>	28
Measuring Mode, Normal Operation	29
<i>Monitoring an Area</i>	29
<i>Using Optional Sample Hoses</i>	30
<i>Snap Log Mode</i>	31

Measuring Mode, Alarms	33
<i>Alarm Indications</i>	33
<i>Responding to Alarms</i>	35
Display Mode	39
<i>Tips for Using Display Mode</i>	39
<i>PID Gas Name Screen</i>	40
<i>Peak Screen</i>	42
<i>STEL Screen</i>	43
<i>TWA Screen</i>	44
<i>View Alarm Settings Screen</i>	44
<i>Time in Operation Screen</i>	46
<i>Date/Time, Battery Voltage Screen</i>	46
<i>Log Time Remaining Screen</i>	47
<i>Clear Data Logging Screen</i>	47
<i>Pump Off Screen</i>	49
<i>Select User ID Screen</i>	50
<i>Select Station ID Screen</i>	51
<i>Viewing Snap Logger Data</i>	52
<i>Peak Bar Screen</i>	54
<i>Gas Display Screen</i>	54
<i>LCD Flip Screen</i>	54
<i>LCD Background Color Flip Screen</i>	55
<i>Language Screen</i>	56
Data Logging	57
Chapter 4: Calibration Mode	58
Overview	58
Calibration Supplies and Equipment	58
Entering Calibration Mode	59
Calibrating Using the Auto Calibration Method	59
<i>Setting the Fresh Air Reading</i>	59
<i>Performing a Span Adjustment in Auto Calibration</i>	62
<i>Returning to Measuring Mode</i>	66
Calibrating Using the Single Calibration Method	67
<i>Setting the Fresh Air Reading</i>	67
<i>Performing a Span Adjustment in Single Calibration</i>	69
Performing a Bump Test	72
Chapter 5: User Mode	77
Overview	77
Tips for Using User Mode	77
Entering User Mode	78
Setting the Date and Time	79
Setting the Date Format	80
Configuring the Channels	80
Updating the Language Setting	80
Viewing the ROM/SUM of the Instrument	81
Turning the Password Function On or Off	81

Exiting User Mode	82
Chapter 6: Maintenance	83
Overview	83
Troubleshooting	83
Replacing or Recharging the Batteries	85
<i>Replacing the Alkaline Batteries</i>	85
<i>Replacing the Lithium Ion Battery Pack</i>	87
<i>Recharging the Lithium Ion Battery Pack</i>	88
<i>Recharging the Lithium Ion Battery Pack Out of the Instrument</i>	90
Replacing the Probe's Particle Filter and Hydrophobic Filter Disk	93
Replacing the PID Sensor	94
Replacing the Hydrophobic Filter and Wire Mesh Disk	97
PID Sensor Maintenance	98
<i>Cleaning the PID Sensor's Lamp</i>	98
<i>Replacing the PID Sensor's Lamp</i>	102
<i>Replacing the PID Sensor's Electrode Stack</i>	105
Chapter 7: General Parts List	109
Appendix A: Maintenance Mode	112
Overview	112
Entering Maintenance Mode	115
Tips for Using Maintenance Mode	117
Setting the Date and Time (DATE)	118
Setting the Date Format (DATE FORMAT)	118
Performing a Calibration (GAS CALIBRATION)	119
Performing a Bump Test (BUMP TEST)	119
Updating Calibration Settings (CAL SETTING)	120
Updating Bump Test Settings (BUMP SETTING)	122
Updating Alarm Parameters (ALARM SETTING)	126
Turning the Pump On/Off Display On or Off (PUMP OFF DISP)	128
Turning the User/Station ID Function On or Off (ID DISPLAY)	128
Updating the Backlight Time Setting (BACK LIGHT TIME)	128
Updating the Language Setting (LANGUAGE)	129
Updating the Lunch Break Setting (LUNCH BREAK)	129
Updating the Auto Zero Setting (AUTO ZERO)	130
Updating the Demand Zero Setting (DEMAND ZERO)	130
Zero Follower Setting (ZERO FOLLOWER)	130
Zero Suppression Settings (ZERO SUPPRESS)	130
Updating the Autoranging Setting (IR AUTO RANGE)	130
Updating the Confirmation Alert Setting (CONFIRMATION)	131
Turning the Key Tone Noise On or Off (KEY TONE)	131
Turning Inert Mode On or Off (INERT MODE)	132
Updating the Leak Check/Bar Hole Mode Setting (L./B. MODE)	132
Setting the Bar Hole Measurement Time (BAR HOLE TIME)	132
Updating the CO Display Setting (CO DISPLAY)	132
Updating the Man Down Settings (MAN DOWN)	132

Updating the Datalogging Parameters (LOG SETTING).....	134
Adjusting the Low Flow Setpoint (FLOW ADJUST)	135
Viewing the ROM/SUM of the Instrument (ROM/SUM)	136
Turning the Password Function On or Off (PASSWORD).....	137
Restoring the Default Settings (RESTORE DEFAULT)	137
Exiting Maintenance Mode (START MEASURE).....	138
Appendix B: Maintenance Mode 2	139
Overview.....	139
Entering Maintenance Mode 2	139
Tips for Using Maintenance Mode 2	141
Changing the Gas Combination (GAS COMB).....	141
Changing the Catalytic LEL Channel's Target Gas (HC SELECT).....	141
Changing the Streaming Setting (STREAMING MODE).....	142
Exiting Maintenance Mode 2	142
Appendix C: 10.0 eV/Benzene PID Sensor.....	143
Overview.....	143
Sensor Description	144
Tube and Tube Holder.....	144
<i>Tube</i>	144
<i>Tube Holder</i>	144
Start Up.....	145
Display Mode	145
Measuring Mode.....	146
Benzene Select Mode	146
Viewing Benzene Select Mode Data.....	152
Calibrating the 10.0 eV/Benzene PID Sensor.....	154
<i>Important Calibration Information</i>	154
<i>Performing an AUTO CAL</i>	155
<i>Performing a SINGLE CAL</i>	155
<i>Performing a TUBE CAL</i>	155
<i>Entering a CAL CODE</i>	162
Maintenance	163
<i>Replacing a Sensor</i>	163
<i>PID Sensor Maintenance</i>	163
<i>Replacing a Tube</i>	163
Parts List.....	165
Appendix D: 11.7 eV PID Sensor	166
Overview.....	166
11.7 eV PID Lamp Warranty.....	166
Description	167
<i>Instrument</i>	167
<i>Sensor</i>	167
<i>Dehumidifier Filter</i>	167
Start Up.....	168
Display Mode	168

Measuring Mode	169
<i>Turning Off a GX-6000 with an 11.7 eV PID Sensor</i>	169
Calibrating the 11.7 eV PID Sensor	170
<i>Setting the Fresh Air Reading</i>	170
<i>Performing an AUTO CAL</i>	170
<i>Performing a SINGLE CAL</i>	170
Maintenance	170
<i>Replacing the Dehumidifier Filter</i>	170
<i>Replacing a Sensor</i>	170
<i>Replacing the PID Sensor's Lamp and Electrode Stack</i>	170
<i>Cleaning the 11.7 eV PID Sensor's Lamp</i>	171
Parts List for 11.7 eV PID Instruments	172

Appendix E: Creating a PID User List..... 173

Overview	173
Materials	173
Procedure	173
<i>Installing the PID Gas List Editor Program</i>	173
<i>Connecting a GX-6000</i>	173
<i>Editing the User List</i>	174

WARNING: *Understand manual before operating. Substitution of components may impair intrinsic safety. To prevent ignition of a hazardous atmosphere, batteries must only be changed or charged in an area known to be nonhazardous. Not tested in oxygen enriched atmospheres (above 21%).*

NOTE: RKI Instruments, Inc. recommends that you refer to ISA-RP12.13, Part II-1987 or an equivalent international recommended practice for guidance in the use of combustible gas detection instruments.

Chapter 1: Introduction

Overview

This chapter briefly describes the GX-6000 Single Sensor PID Model gas monitor. This chapter also describes the *GX-6000 Single Sensor PID Model Operator's Manual* (this document). Table 1 at the end of this chapter lists the specifications for the GX-6000 Single Sensor PID Model (hereafter referred to as the GX-6000).

About the GX-6000

The GX-6000's rugged, reliable, and easy-to-use design makes it ideally suited for a wide range of applications, including sewage treatment plants, utility manholes, tunnels, hazardous waste sites, power stations, petrochemical refineries, mines, paper mills, drilling rigs, and fire fighting stations. The GX-6000 offers a full range of features including:

- VOC monitoring
- Sample-drawing pump with up to 50 foot range
- Liquid crystal display (LCD) for complete and understandable information at a glance
- Ultrabright alarm LEDs
- Distinctive audible/vibrating alarms for dangerous gas conditions and audible alarms for unit malfunction
- Microprocessor control for reliability, ease of use, and advanced capabilities
- Data logging functions
- Alarm trend data
- STEL and TWA (for high range PID only) and over range alarms
- Peak reading
- Built-in time function
- Lunch break feature
- RF shielded high impact plastic case
- CSA classification, "C/US", for Class I, Division I, Groups A, B, C, and D hazardous atmospheres

WARNING: *The Model GX-6000 detects elevated levels of VOC gases which can be dangerous or life threatening. When using the GX-6000, you must follow the instructions and warnings in this manual to assure proper and safe operation of the unit and to minimize the risk of personal injury. Be sure to maintain and periodically calibrate the GX-6000 as described in this manual.*

Specifications

Table 1: Sensor Specifications/Alarm Points

	VOCs, Isobutylene Calibration Standard	
	Low Range PID	High Range PID
Detection Range	0 - 50000 ppb	0 - 6000 ppm
Reading Increment	<ul style="list-style-type: none"> • 0 - 5000: 1 ppb • 5000 - 50000: 10 ppb 	<ul style="list-style-type: none"> • 0 - 600 ppm: 0.1 ppm • 600 - 6000 ppm: 1 ppm
Alarm 1 Factory Setting	5000 ppb	400 ppm
Alarm 2 Factory Setting	10000 ppb	1000 ppm
STEL Alarm	n/a	60.0 ppm
TWA Alarm	n/a	40.0 ppm

Table 2: GX-6000 Specifications

Sampling Method	Sample Draw
Response Time	T90 Within 30 Seconds
Display	Graphics LCD Display
Operating Temperature & Humidity	-20°C to 50°C/Below 95% RH (Without Condensation)
Indication Accuracy	± 10% of reading or ± 1 increment (whichever is greater)
Safety/Regulatory	<ul style="list-style-type: none"> • ATEX: II 1 G Ex ia IIC T4 Ga Certificate Number Presafe 15ATEX6171 • IECEx: Ex ia IIC T4 Ga Certificate Number PRE 15.0011 • CSA classified, "C/US", as Intrinsically Safe. Exia. Class I, Groups A, B, C, & D. Temperature Code T3A. <div style="text-align: center;">  <p>C US 186718</p> </div>
Power Supply	<ul style="list-style-type: none"> • Three AA size alkaline batteries OR <ul style="list-style-type: none"> • One lithium ion battery pack

Continuous Operating Hours @ 25 °C	<ul style="list-style-type: none"> Alkaline Batteries: 20 Hours (Non Alarm Operation, Fully Charged) Li-ion Battery Pack: 25 Hours (Non Alarm Operation, Fully Charged)
Case	High-impact Plastic, RF Shielded, Dust and Weather Proof
Included Accessories	<ul style="list-style-type: none"> Belt clip Red rubber boot Wrist strap Tapered nozzle Screen protector 3 foot hose and probe VOC zero filter (included for instruments with a low range PID sensor, a 10.0 eV/ benzene PID sensor, or an 11.7 eV PID sensor)
Other Accessories	<ul style="list-style-type: none"> Alkaline Battery Pack Rechargeable Li-ion Battery Pack 115 VAC Charger 12 VDC Charger Hose/Probes of Various Lengths, See "Chapter 7: General Parts List" on page 109. VOC Zero Filter (optional for instruments with a high range PID sensor) DIN Rail Mounting Assembly (for mounting chargers to the wall) Product CD, includes Data Logger Management Program IrDA/USB Cable for connecting to a computer when using the Data Logger Management Program (not needed if computer has an infrared port)
Dimensions and Weight	<p>Approximately 200(H) x 68(W) x 52(D) mm (7.9"H x 2.7"W x 2.0"D)</p> <p>Approximately 400 g (14 oz.)</p>

About this Manual

Although the GX-6000 can support up to 6 sensors, this manual specifically describes an instrument with only a PID sensor installed.

The *GX-6000 Single Sensor PID Model Operator's Manual* uses the following conventions for notes, cautions, and warnings.

NOTE: Describes additional or critical information.

CAUTION: *Describes potential damage to equipment.*

WARNING: *Describes potential danger that can result in injury or death.*

Chapter 2: Description

Overview

This chapter describes the GX-6000 instrument and accessories.

Instrument Description

The GX-6000 includes the case, LCD, control buttons, flashlight LED, alarm LEDs, infrared communication port, buzzer, vibrator, printed circuit board, pump, flow chamber, sensor, filters, inlet filter holder, and batteries.

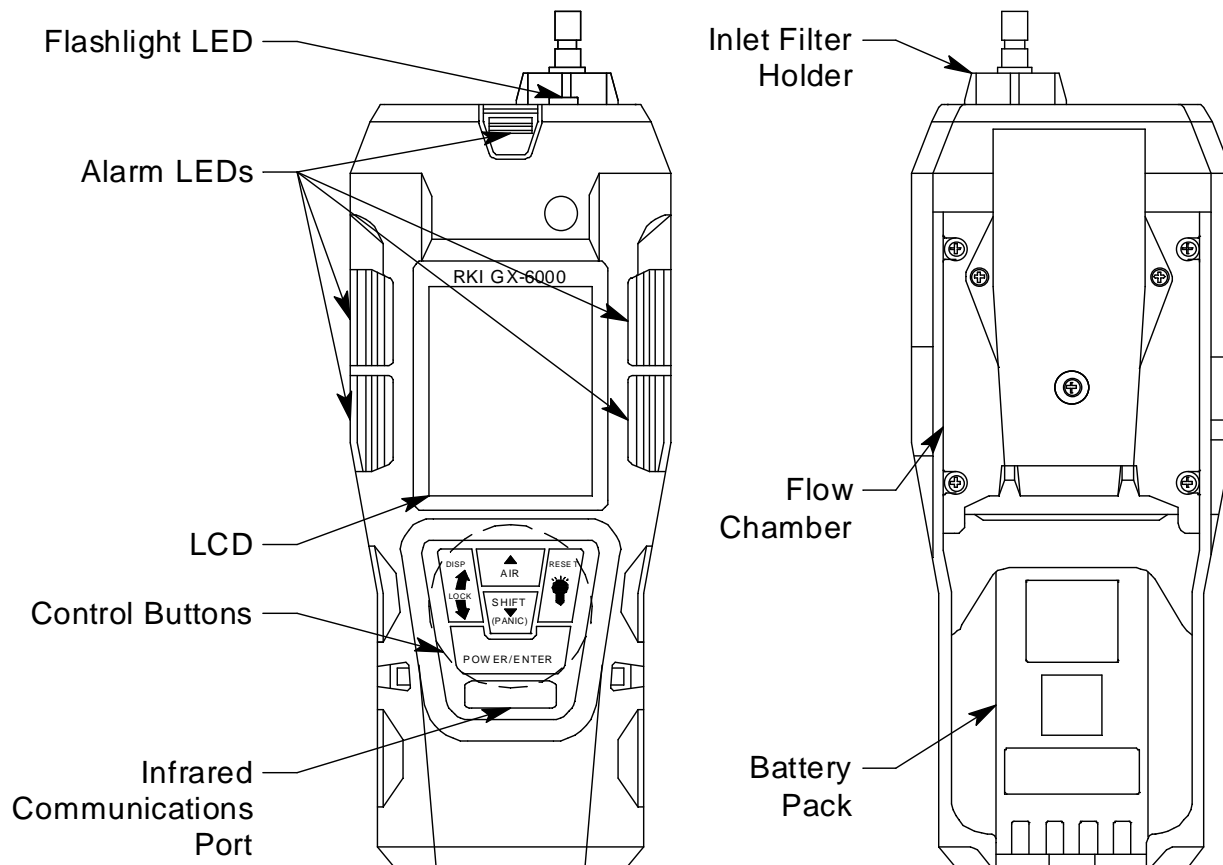

Figure 1: Component Location

Case

The GX-6000's sturdy, high-impact plastic case is radio frequency (RF) resistant and is suitable for use in many environmental conditions, indoors and out. The case is dust proof and water resistant. A clear plastic window is located on the front of the case. The battery pack and flow chamber are located on the back of the GX-6000. The inlet filter holder is located on the top of the GX-6000 case.

LCD

A digital LCD (liquid crystal display) is visible through a clear plastic window in the top case. The LCD shows the gas reading. The LCD also shows information for each of the GX-6000's operating modes.

Control Buttons

Five control buttons are located below the LCD. They are, from left to right and top to bottom, DISP/LOCK, ▲ AIR, SHIFT ▼ (PANIC), POWER/ENTER, and RESET.

Table 3: GX-6000 Control Button Functions

Button	Function(s)
DISP/LOCK	<ul style="list-style-type: none">• activates Display Mode• enters instructions into the GX-6000's microprocessor• allows you to exit a menu without saving changes• locks screen orientation in any mode if INVERSION SELECT is set to ON
▲ AIR	<ul style="list-style-type: none">• activates the demand zero function (adjusts the GX-6000's fresh air reading)• enters instructions into the GX-6000's microprocessor• moves the cursor on the LCD up the screen• increases the value of a parameter available for adjustment• scrolls through parameter options
SHIFT ▼ (PANIC)	<ul style="list-style-type: none">• enters instructions into the GX-6000's microprocessor• moves the cursor on the LCD down the screen• decreases the value of a parameter available for adjustment• scrolls through parameter options• initiates a Panic alarm in any mode if PANIC is set to ON
POWER/ENTER	<ul style="list-style-type: none">• turns the GX-6000 on and off• enters instructions, values, and settings into the GX-6000's microprocessor
RESET	<ul style="list-style-type: none">• silences and resets audible alarm if ALARM LATCHING is set to LATCHING and ALARM SILENCE is set to ON• turns the flashlight LED on and off

Flashlight LED

A white LED is visible through a round, raised, frosted lens in the top of the case. This LED can be used to provide extra light, if necessary. The RESET button turns this LED on and off.

Alarm LEDs

Five sets of red alarm LEDs (light emitting diodes) border the LCD. The alarm LEDs alert you to gas, low battery, and failure alarms.

Infrared Communications Port

An infrared (IR) communications port is located on the front of the case, below the POWER/ENTER button. The data transmitted through the port is in standard IrDA protocol. A computer's infrared port or an IrDA/USB cable connected to a USB port can be used to download data saved by the GX-6000 to a computer using the GX-6000 Data Logger Management Program. See the GX-6000 Data Logger Management Program operator's manual for data logging and downloading instructions.

Buzzer

One solid-state electronic buzzer is located inside the case. Holes on the top front of the case allow the sound to exit the case. The buzzer sounds for gas alarms, malfunctions, low battery voltage, and as an indicator during use of the GX-6000's many display and

adjustment options.

Vibrator

A vibrating motor inside the GX-6000 case vibrates for gas alarms, unit malfunctions, and as an indicator during normal use of the various modes of the GX-6000.

Printed Circuit Boards (PCBs)

The GX-6000 printed circuit boards analyze, record, control, store, and display the information collected. The circuit boards are located inside the case. They are not user serviceable.

Pump

A diaphragm pump inside the GX-6000 draws the sample to the sensor. It can draw sample from as far as 50 feet from the GX-6000. The pump is not user serviceable.

CAUTION: *Sample hose lengths of more than 50 feet are not recommended for the GX-6000 because of flow rate reduction.*

Flow Chamber

The flow chamber is on the back of the GX-6000 and is held in place by four Phillips screws. The flow chamber seals to the rubber sensor gasket which seals to the sensor face inside the GX-6000 and routes flow from the pump to the sensor and to the exhaust port (on the top of the GX-6000 case).

Sensors

PID Sensor

Two types of PID sensors can be used with the GX-6000, a low range (higher sensitivity) sensor and a high range (lower sensitivity) sensor (see Table 1 for specifications).

The PID sensor is a cylindrical sensor with a diffusion opening on the front and 3 pins on the back. It is installed in a white housing that has three sockets on the bottom that mate with the GX-6000 instrument. The PID sensor must always be installed in the first smart sensor position which is located in the top left corner of the sensor block.

The standard calibration for a PID channel is to isobutylene. A PID channel can be factory setup for and calibrated to other gases. Regardless of the calibration gas, the PID channel will still detect and respond to a variety of volatile organic compounds (VOCs). Consult RKI Instruments, Inc. for other available PID configurations and to specify the desired PID configuration when a unit is ordered.

Dummy Sensors

This version of the GX-6000 has 5 dummy sensors installed in the unused sensor positions. Dummy sensors are factory installed. The flat top of the dummy sensor should face up and the bottom hollow side should face down.

Inlet Filter Holder

The filter holder is a clear plastic dome shaped piece on the top of the case. A male quick connect fitting is located on the inlet filter holder. This is the GX-6000's inlet fitting. The filter holder may be removed by turning it counterclockwise and pulling it away from the case. One flat membrane disk hydrophobic filter, a wire mesh disk, and a rubber filter retaining gasket are held in place by the filter holder and are located in the bottom of the case chamber where the filter holder is installed.

Batteries

Three AA-size alkaline batteries or a rechargeable lithium ion battery pack (4.1 VDC) power the GX-6000. Instrument run time is dependent upon battery type. At 25°C the alkaline batteries last at least 20 hours and the lithium ion battery pack lasts at least 25 hours. The battery icon in the upper right of the LCD shows remaining battery life.

When the GX-6000 detects a low battery voltage, a low battery warning is activated. When battery voltage is too low for Measuring Mode, the GX-6000 sounds a dead battery alarm.

The alkaline batteries can be replaced by removing the battery cover on the back of the case. The lithium ion pack can be replaced by removing the entire battery pack. The battery pack release latch is located on the bottom of the instrument. When viewing the instrument from the bottom with the LCD facing down, push the battery pack release latch toward the right to release the pack.

The lithium ion battery pack can be recharged by placing the GX-6000 in its battery charging station or by placing the battery pack in the charging station.

NOTE: Use of batteries or battery chargers not specified by RKI Instruments, Inc. will compromise the CSA classification and may void the warranty. See “Replacing or Recharging the Batteries” on page 85.

WARNING: *To prevent ignition of a hazardous atmosphere, batteries must only be changed or charged in an area known to be nonhazardous.*

AVERTISSEMENT: *Pour éviter l'inflammation d'une atmosphère dangereuse, les batteries doivent uniquement être modifiés ou facturés dans une zone connue comme non dangereuse.*

Included Accessories

Included accessories consist of the tapered rubber nozzle, belt clip, rubber boot, wrist strap, and the sample hose/probe.

Tapered Rubber Nozzle

A cone shaped 4 inch long rubber nozzle is included with the GX-6000 as standard. It can be installed on the inlet fitting by pushing the larger end over it. The smaller end can be inserted through a hole in a wall or some other access to an enclosed area to sample the environment.

Belt Clip

A belt clip can be mounted to the back of the case using 3 Phillips head screws. The belt clip allows the GX-6000 to be securely attached to a belt.

Rubber Boot

A red protective rubber boot can be installed over the GX-6000.

Wrist Strap

A wrist strap is included with the GX-6000 and can be attached to the right or left wrist strap installation feature on the GX-6000 case.

Sample Hose and Probe

A 3 foot sample hose with an attached probe is standard with the GX-6000. When desired, the rubber nozzle may be removed and the sample hose and probe may be connected to the inlet fitting. Sample hose lengths are available from 3 feet to 50 feet (see “Chapter 7: General Parts List” on page 109). The quick connect end of the sample hose connects to the inlet fitting of the GX-6000. The probe is integral with the hose and connects to it with a tube fitting.

CAUTION: *Sample hose lengths of more than 50 feet are not recommended for the GX-6000 because of flow rate reduction.*

The probe includes a replaceable particle filter and hydrophobic filter disk that prevent particulates and water from entering the GX-6000’s flow system. See “Replacing the Probe’s Particle Filter and Hydrophobic Filter Disk” on page 93 for instructions to replace the particle filter and hydrophobic filter disk.

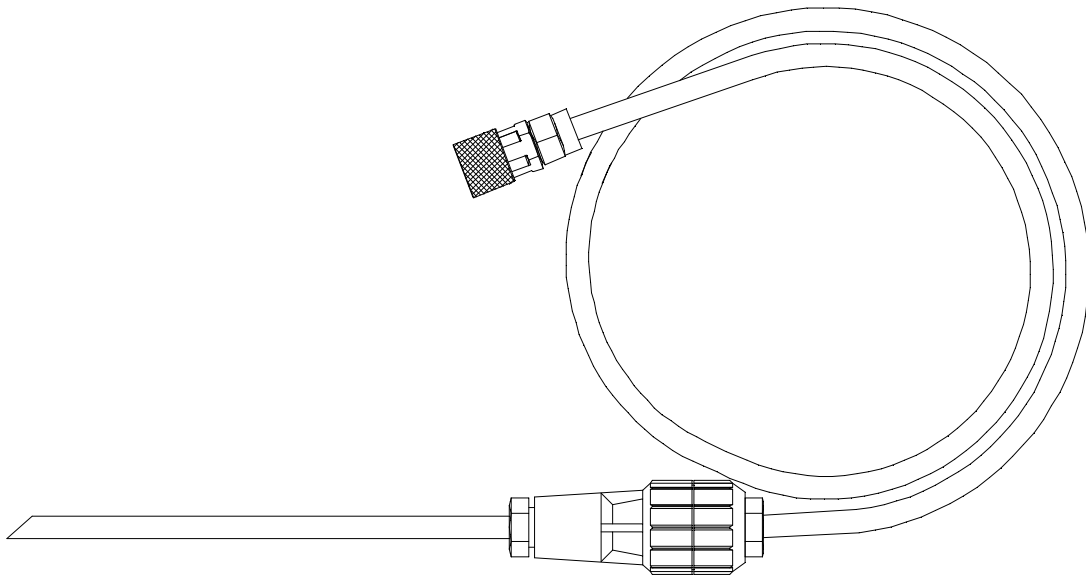

Figure 2: Sample Hose and Probe

Screen Protector

The clear screen protector can be installed over the GX-6000’s LCD to prevent it from getting scratched.

1. Remove the GX-6000’s rubber boot.
2. Orient the GX-6000 so that the LCD is as horizontal as possible.
3. Clean the LCD with rubbing alcohol.
4. Place 1 drop of water in the center of the LCD.
5. Grasp the tab at the top of the screen protector’s backing and pull it away from the screen protector.

6. Use needle-nose pliers or tweezers to handle the screen protector.
7. Align the top of the screen protector with the top of the “RKI GX-6000” logo.
8. Press down on the center of the screen protector. Water should spread out along the entire surface of the screen protector between the screen protector and the LCD. Some of the water may come out the edges.
9. If you are unhappy with the initial placement of the screen protector, lift the screen protector up from a corner. Quickly rearrange the screen protector and set it back down on the LCD.
10. Use a small, stiff piece of plastic and, working your way out from center, remove any air bubbles. The screen protector may shift during this process so be sure to hold it securely with your other hand.
11. Allow enough time for the water between the screen protector and the LCD to dry before handling the GX-6000.
12. Reinstall the rubber boot.

Other Accessories

Several other accessories are available for the GX-6000. This section describes the VOC zero filter and the DIN rail. Data logging accessories are briefly described in “Data Logging” on page 57.

VOC Zero Filter

The VOC zero filter scrubs out low levels of VOC gases using charcoal. A VOC zero filter is included as standard with GX-6000s that include a low range PID sensor, a 10.0 eV/ benzene PID sensor, or an 11.7 eV PID sensor since these sensors are more susceptible to low levels of VOCs. A VOC zero filter is not included with GX-6000s that include a high range PID sensor. Use the VOC zero filter when performing an air adjust on a PID sensor in an area that may have a low-level VOC background. The filter comes with a tubing stub and plug on each end. Both plugs must be removed before using the filter and must be reinstalled for storage. The filter does not have a preferred flow direction.

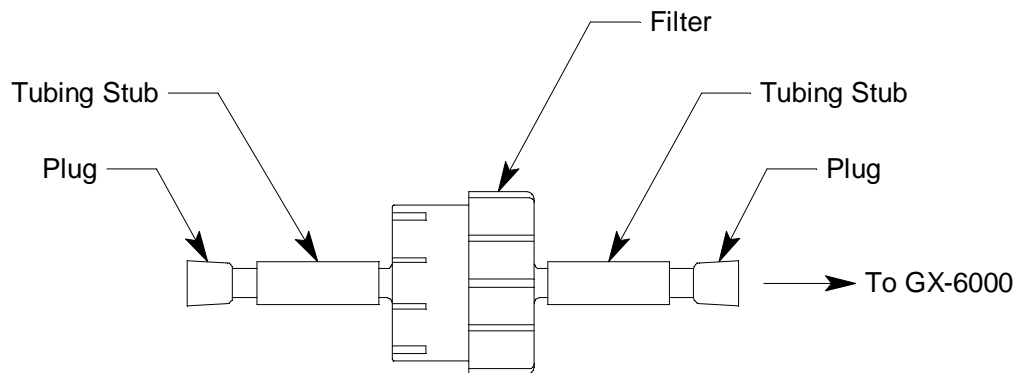

Figure 3: VOC Zero Filter

DIN Rail Mounting Assembly

Two different DIN rail mounting assemblies are available for the GX-6000's charger. Each assembly has two end clamps but one assembly is long enough to accommodate 1 charger and the other assembly is long enough to accommodate 4 chargers.

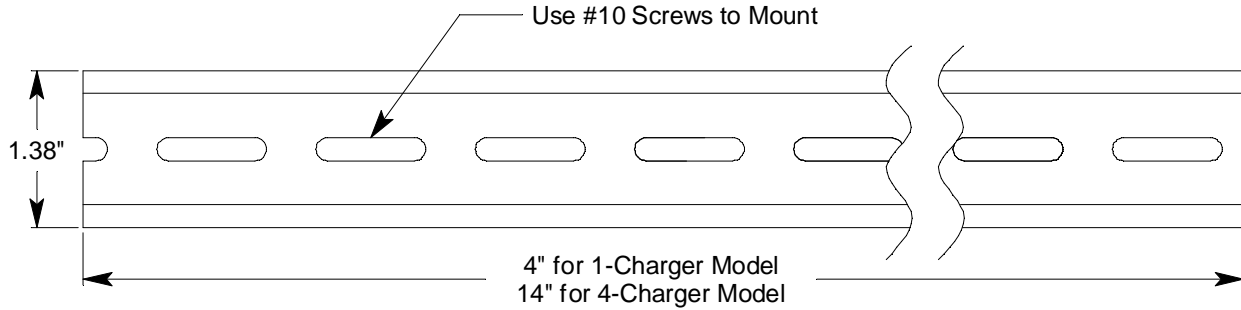

Figure 4: DIN Rail Dimensions

1. Use #10 screws to mount the DIN rail to the wall.
2. Install the charger(s) on the DIN rail. Seat the top of the DIN rail in the top slot on the back of the charger. Press the bottom of the charger toward the DIN rail until it locks into place.

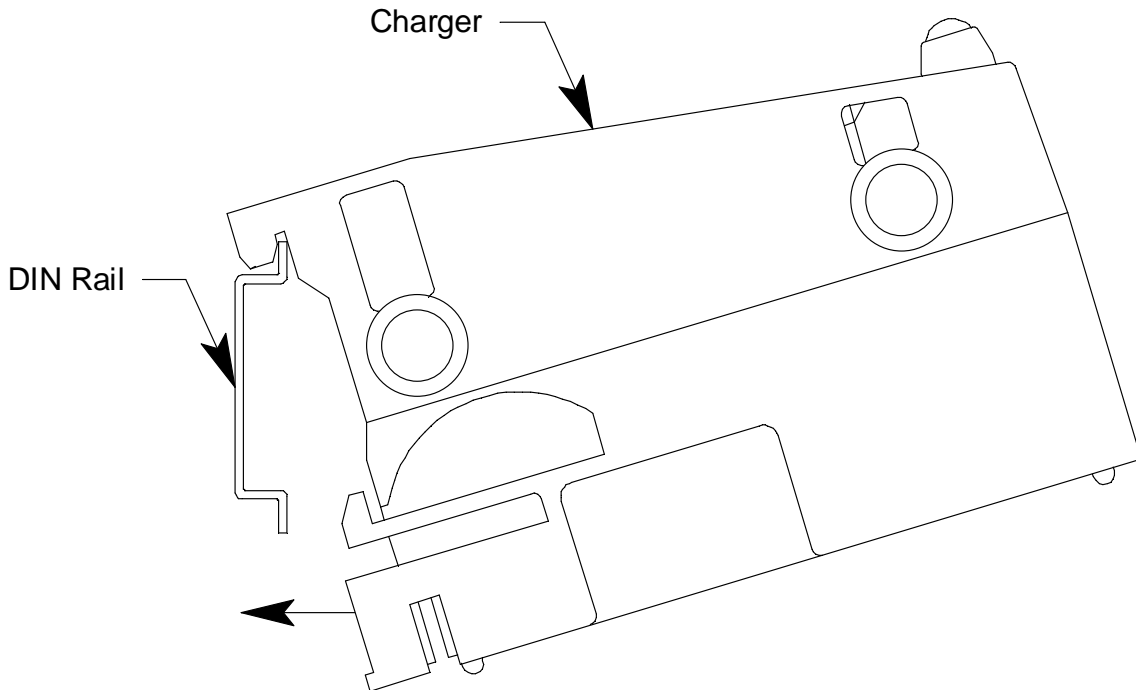

Figure 5: Installing a Charger on the DIN Rail

3. Slide the charger(s) along the DIN rail into the desired position.

4. Install the end clamps on the left and right side of the charger or bank of chargers to prevent sliding.

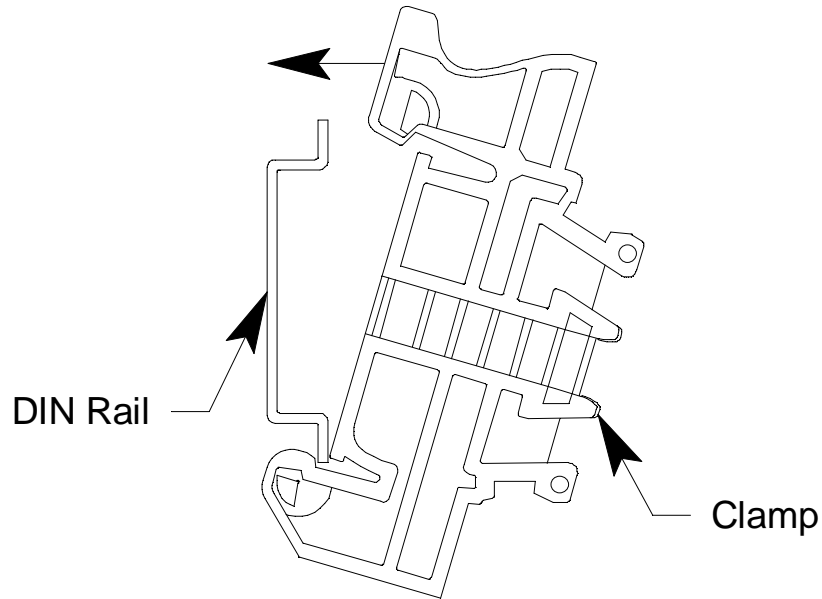

Figure 6: Clamp Installation

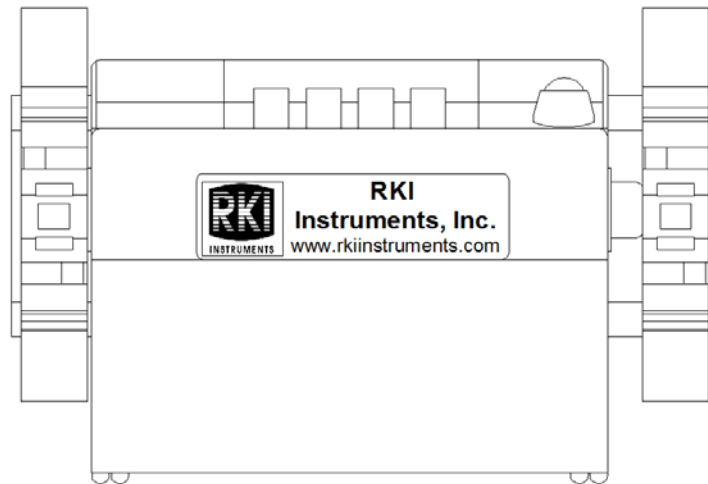

Figure 7: 1-Charger Installation

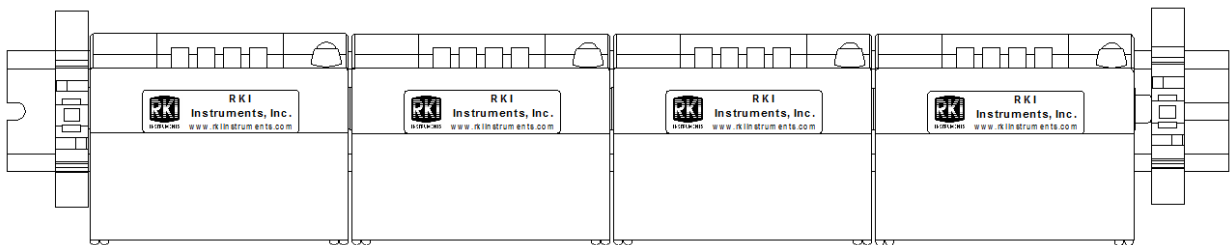

Figure 8: 4-Charger Installation

5. To remove any charger(s) from the DIN rail:
 - a. Remove the clamps by pushing on the bottom of the clamp and pulling on the top of the clamp.
 - b. Slide the charger(s) off the DIN rail.

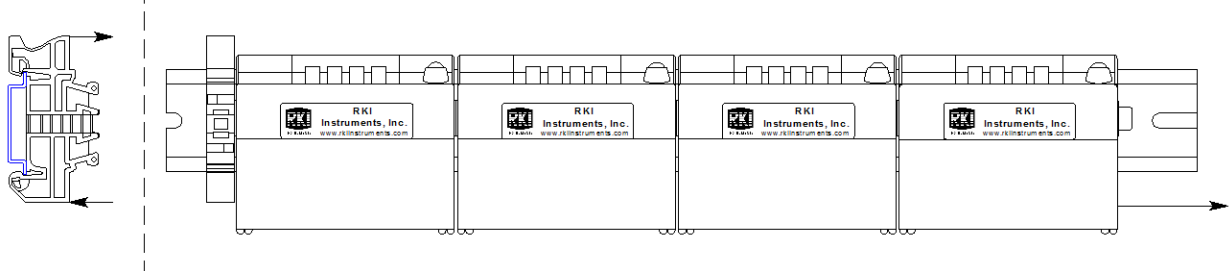

Figure 9: Charger Removal

Chapter 3: Operation

Overview

This chapter explains how to use the GX-6000 to perform confined space entry monitoring or general area monitoring in Normal Mode. There are three operational modes in Normal Mode: Measuring Mode, Display Mode, and Calibration Mode. While in Normal Mode, the unit is normally operating in Measuring Mode. Display Mode and Calibration Mode are accessible from Measuring Mode. Display Mode is described in this chapter. Calibration Mode is described in “Chapter 4: Calibration Mode” on page 58.

Start Up

This section explains how to start up the GX-6000, get it ready for operation, and turn it off.

Turning On the GX-6000

To illustrate certain functions, the following description of the GX-6000 start up sequence assumes that the following menu items in Maintenance Mode are turned on: **LUNCH BREAK**, **CAL REMINDER**, **BUMP REMINDER**, and **ID DISPLAY**. If any of these items are turned off, then the corresponding screens will not appear.

The GX-6000 may be used with a sample hose and probe or with the tapered rubber nozzle. Determine which configuration works best for your application.

NOTE: When the sample hose is not being used, its outgassing characteristics may result in a small buildup of gas to which the PID sensor will respond. If a sample hose has been sitting unused for a period of time, when that sample hose is connected to a GX-6000, the PID channel may temporarily show a reading. The reading will return to a fresh air reading after all of the built up gas has been drawn out of the sample hose.

- 1 . Connect the tapered rubber nozzle or the sample hose and probe to the GX-6000's quick connect inlet fitting.
- 2 . Press and briefly hold down the POWER/ENTER button. Release the button when you hear a beep.

3. If **LUNCH BREAK** is turned on (see “Updating the Lunch Break Setting (LUNCH BREAK)” on page 129), the Lunch Break Screen appears. The unit counts down from 5 seconds at the top of the screen.

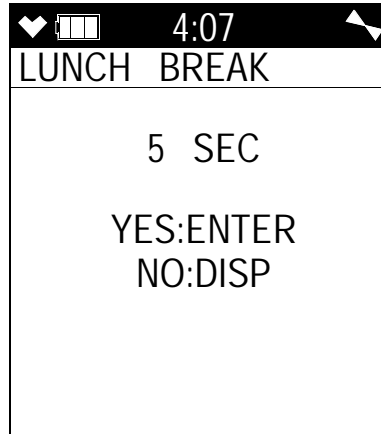

- To continue accumulating peak and time-weighted average (TWA) readings (high range PID only) from the last time the GX-6000 was used, press and release the POWER/ENTER button before the countdown reaches 0 or allow the countdown to reach 0. If you do not press the POWER/ENTER button within the 5 second countdown, the GX-6000 automatically resumes accumulating the peak and TWA readings. The GX-6000 will also continue to keep track of operating time including the operating time from the last time the GX-6000 was used. See “Time in Operation Screen” on page 46 for more information about how the GX-6000 tracks the operating time. The short-term exposure limit (STEL) reading is reset each time the GX-6000 is turned on.
 - To reset the accumulation of these measurements, press and release the DISP/ LOCK button before the countdown reaches 0.
4. If **CAL REMINDER** is set to **ON**, the screen that appears next depends on how **CAL EXPRD** is set in Maintenance Mode (see “Updating the Calibration Expired Setting (CAL EXPRD)” on page 121).
- If the unit is due for calibration and **CAL EXPRD** is set to **CONFIRM TO USE**, then the following screen displays and the buzzer sounds in a double pulsing pattern.

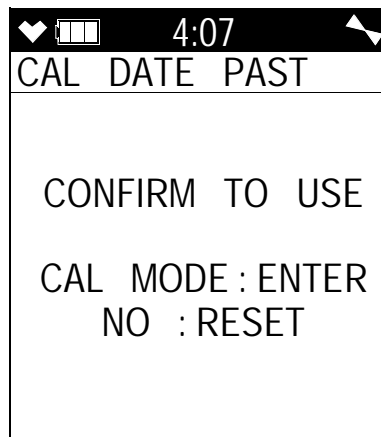

To perform a calibration, press and release the POWER/ENTER button. The GX-6000 will enter Calibration Mode and the LCD will show the Calibration Mode main menu. See “Chapter 4: Calibration Mode” on page 58 for

instructions to calibrate the GX-6000. When you are done with the calibration and exit Calibration Mode, the unit will begin the startup sequence. If the calibration was successful, the screen above will not appear again until the unit is due for calibration. If the calibration was not successful, the screen above will again appear in the startup sequence.

To continue without performing a calibration, press and release the RESET button.

- If the unit is due for calibration and **CAL EXPRD** is set to **CANNOT USE**, then the following screen displays and the buzzer sounds in a double pulsing pattern.

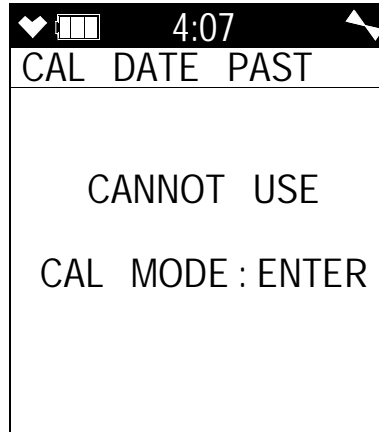

The GX-6000 cannot be used until a successful calibration has been performed. Press and release the POWER/ENTER button to enter Calibration Mode. See “Chapter 4: Calibration Mode” on page 58 for instructions to calibrate the GX-6000.

NOTE: In this situation, even if the User password function has been turned on, no password is required to perform a calibration.

When you are done with the calibration and exit Calibration Mode, the unit will begin the startup sequence. If the calibration was successful, the screen above will not appear again until the unit is due for calibration. If the calibration was not successful, the screen above will again appear in the startup sequence.

- If the unit is due for calibration and **CAL EXPRD** is set to **NO EFFECT**, then the following alert screen displays and the buzzer sounds in a double pulsing pattern.

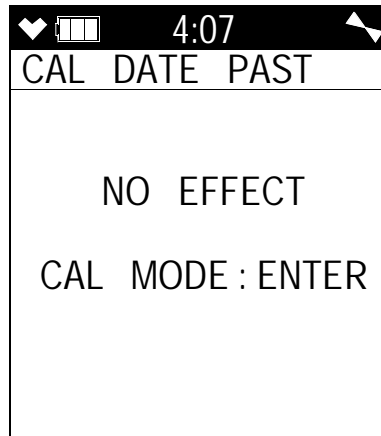

If you want to enter Calibration Mode, press and release the POWER/ENTER button. If you do not want to enter Calibration Mode, wait for the instrument to continue with its startup sequence.

5. If **BUMP REMINDER** is set to **ON** (factory setting is **OFF**), the screen that appears next depends on how **BUMP EXPRD** is set in Maintenance Mode (see “Updating the Bump Expired Setting (BUMP EXPRD)” on page 125).
 - If the unit is due for bump testing and **BUMP EXPRD** is set to **CONFIRM TO USE**, then the following screen displays and the buzzer sounds in a double pulsing pattern.

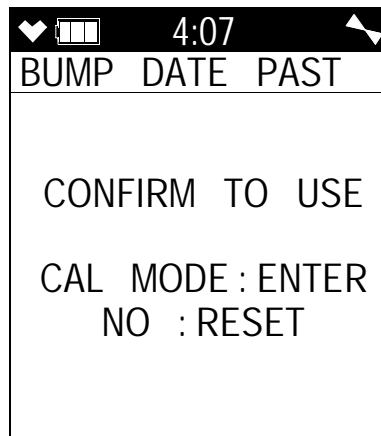

To perform a bump test, press and release the POWER/ENTER button. The GX-6000 will enter Calibration Mode and the LCD will show the Calibration Mode main menu. See “Chapter 4: Calibration Mode” on page 58 for instructions to bump test the GX-6000. When you are done with the bump test and exit Calibration Mode, the unit will begin the startup sequence. If the bump test was successful, the screen above will not appear again until the unit is due for bump testing. If the bump test was not successful, the screen above will again appear in the startup sequence.

To continue without performing a bump test, press and release the RESET button.

NOTE: If **BUMP DISP** is set to **OFF**, the bump test menu item will not appear in Calibration Mode even though the instrument is prompting you to perform a bump test. A bump test can always be performed in Maintenance Mode, if necessary.

- If the unit is due for bump testing and **BUMP EXPRD** is set to **CANNOT USE**, then the following screen displays and the buzzer sounds in a double pulsing pattern.

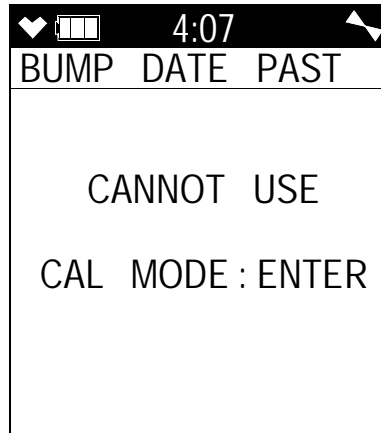

The GX-6000 cannot be used until a successful bump test has been performed. Press and release the POWER/ENTER button to enter Calibration Mode. See “Chapter 4: Calibration Mode” on page 58 for instructions to bump test the GX-6000.

NOTE: In this situation, even if the User password function has been turned on, no password is required to perform a bump test.

NOTE: If **BUMP DISP** is set to **OFF**, the bump test menu item will not appear in Calibration Mode even though the instrument is prompting you to perform a bump test. A bump test can always be performed in Maintenance Mode, if necessary.

When you are done with the bump test and exit Calibration Mode, the unit will begin the startup sequence. If the bump test was successful, the screen above will not appear again until the unit is due for bump testing. If the bump test was not successful, the screen above will again appear in the startup sequence.

- If the unit is due for bump testing and **BUMP EXPRD** is set to **NO EFFECT**, then the following alert screen displays and the buzzer sounds in a double pulsing pattern.

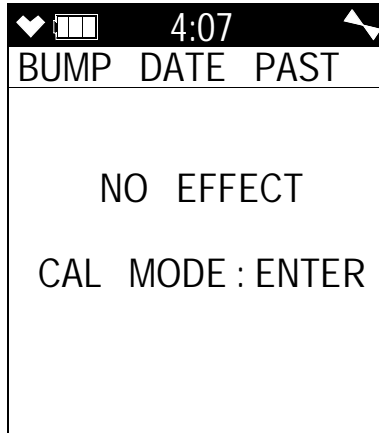

If you want to enter Calibration Mode, press and release the POWER/ENTER button. If you do not want to enter Calibration Mode, wait for the instrument to continue with its startup sequence.

NOTE: If **CAL REMINDER** or **BUMP REMINDER** or both are set to **OFF**, a WARM-UP screen will display before the warm up sequence continues.

6. The Date/Time Screen appears for a few seconds.

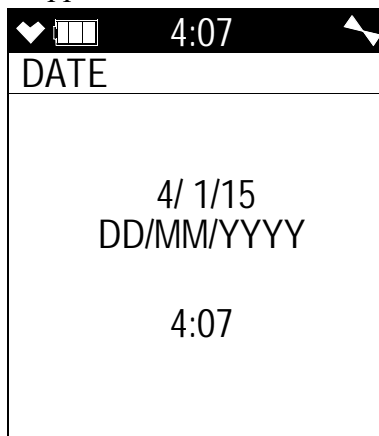

7. The Battery Voltage Screen appears for a few seconds.

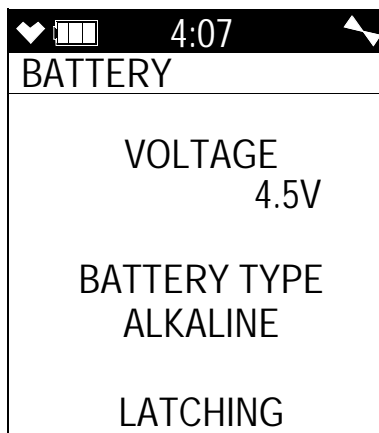

8. The Active Gases Screen appears for a few seconds indicating the active channel and its target gas.

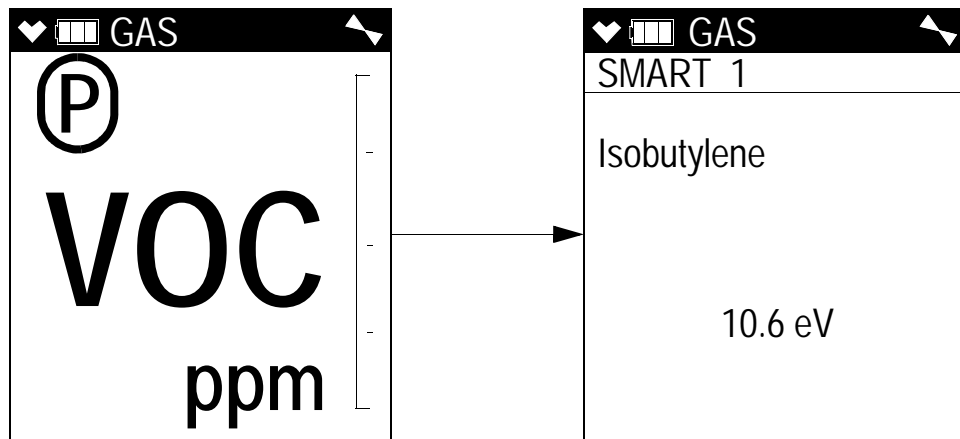

9. The full scale value and the gas alarm setpoints are displayed by five screens in sequence: the Full Scale Screen, the Low Alarm Screen, High Alarm Screen, STEL Alarm Screen (high range PID only), and TWA Alarm Screen (high range PID only). Each screen remains on the LCD for three seconds.

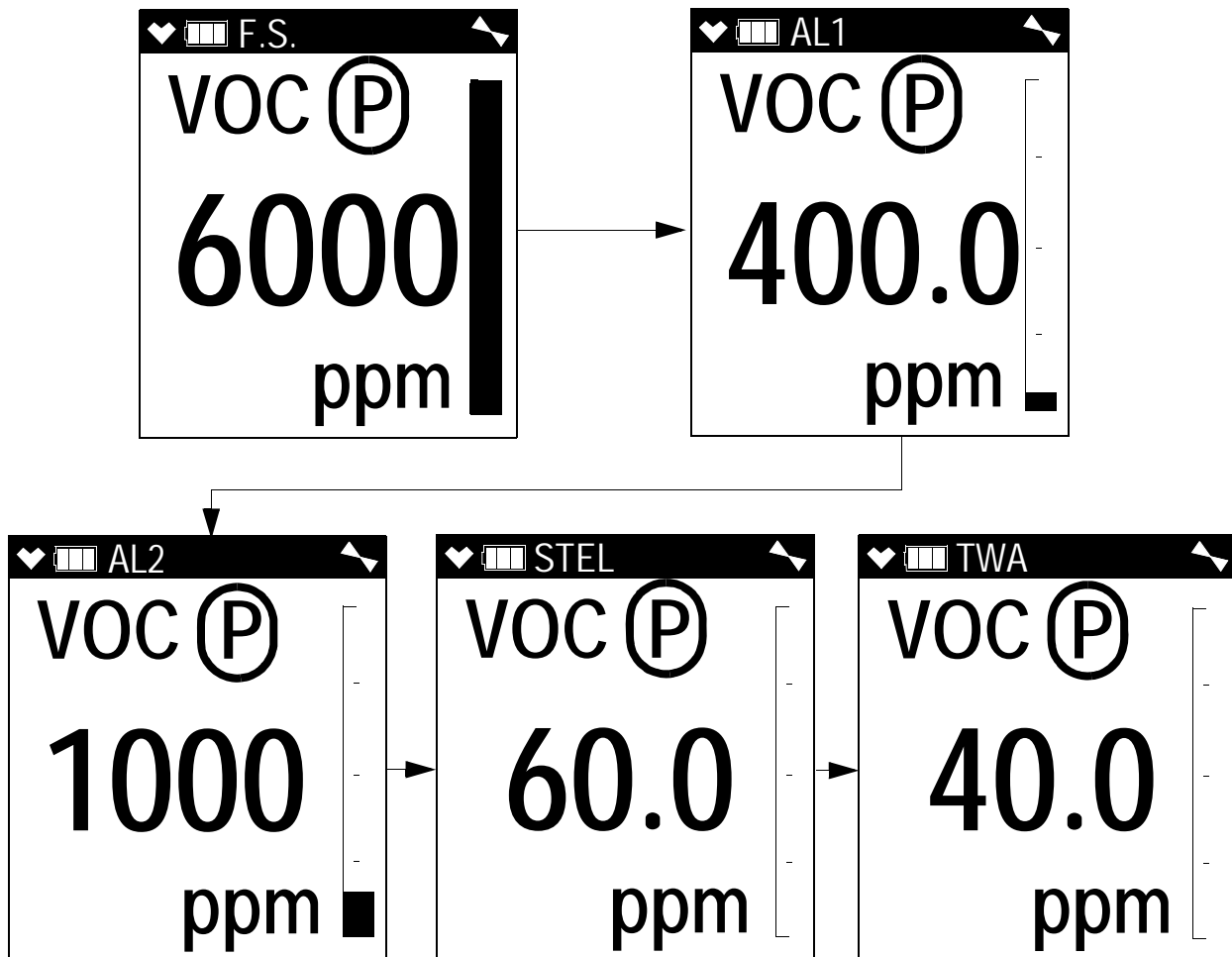

- 10 . If **ID DISPLAY** is set to **ON** (see “Turning the User/Station ID Function On or Off (ID DISPLAY)” on page 128), the User ID Screen appears for a few seconds, followed by the Station ID Screen.

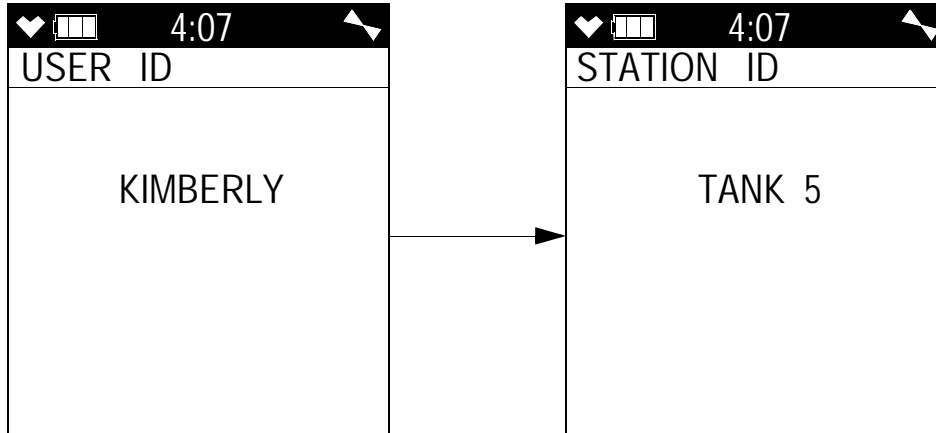

If **ID DISPLAY** is set to **OFF**, these screens will not appear.

- 11 . If the PID sensor fails during start up, the screen indicates the failure and the buzzer sounds a double pulsing tone once per second.

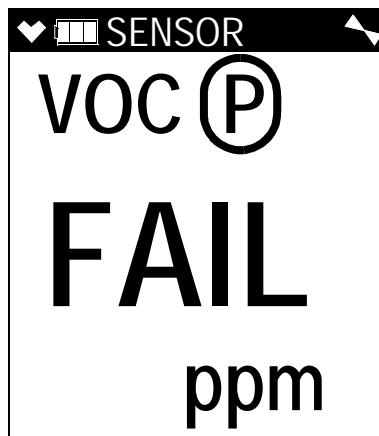

The GX-6000 cannot be used if the PID sensor fails. Turn the instrument off and replace the sensor.

- 12 . The GX-6000 is now monitoring for gas in Measuring Mode. The Measuring Mode Screen appears displaying the current gas reading.

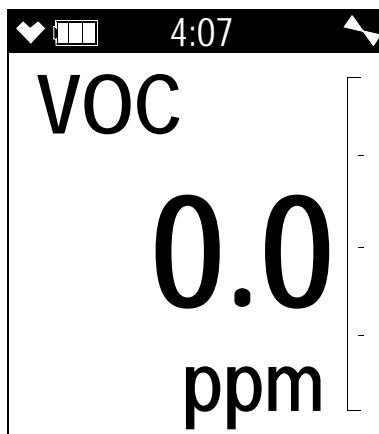

Performing a Demand Zero

Before using the GX-6000, it is recommended to set the fresh air reading by performing a demand zero. This will set the PID channel to 0 ppm.

- 1 . Find a fresh-air environment. This is an environment free of toxic or combustible gases and of normal oxygen content (20.9%).
- 2 . Turn on the unit as described above in “Turning On the GX-6000”.
- 3 . If you suspect any low-level VOC background in the area, you will need to use the VOC zero filter.
 - a. Remove the plug from each end of the VOC zero filter.
 - b. Attach the VOC zero filter to the inlet fitting or probe. The filter does not have a preferred flow direction.
 - c. Let the instrument draw through the VOC zero filter for 1 minute before continuing.
- 4 . Press and hold the ▲ AIR button. The LCD prompts you to continue holding the ▲ AIR button and the buzzer will pulse while you hold the button.
- 5 . Continue to hold the ▲ AIR button until the LCD prompts you to release it. The GX-6000 will set the fresh air reading. Start up is complete and the unit is now ready for monitoring.
- 6 . If the VOC zero filter was used, remove the filter from the GX-6000’s inlet fitting or probe. Reinstall the plugs on each end of the filter.

Turning Off the GX-6000

- 1 . Press and hold the POWER/ENTER button.
- 2 . TURN OFF will appear on the display and the buzzer will pulse for about five seconds.
- 3 . Release the button when TURN OFF disappears from the display.

Measuring Mode, Normal Operation

When the GX-6000 completes its startup sequence, it is in Measuring Mode. In Measuring Mode the GX-6000 continuously monitors the sampled atmosphere and displays the gas concentration present. In a low-light environment, press and release any button to turn on the display backlight. See “Updating the Backlight Time Setting (BACK LIGHT TIME)” on page 128 to program backlight duration. If **CONFIRMATION** is set to **ON** in the Maintenance Mode menu (see “Updating the Confirmation Alert Setting (CONFIRMATION)” on page 131), the GX-6000 beeps periodically to confirm that it’s operating.

Monitoring an Area

1. Start up the GX-6000 as described above in “Start Up” on page 20. It is now in Measuring Mode.

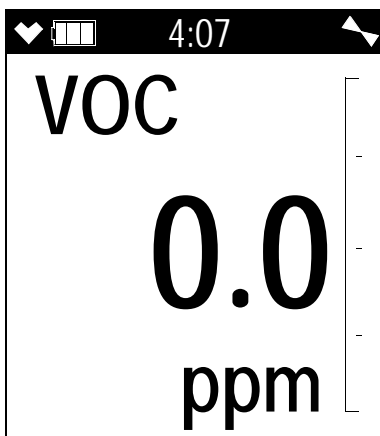

2. Take the GX-6000 to the monitoring area.
3. Put the probe tip in the area to be monitored.

NOTE: If the particle filter or hydrophobic filter become dirty or clogged, replace them. If water enters the probe, dry out or replace the particle filter (if installed) and shake any water out of the probe and off of the hydrophobic filter. If you notice that water has entered the flow system through the probe, replace the probe’s hydrophobic filter. See “Replacing the Probe’s Particle Filter and Hydrophobic Filter Disk” on page 93 for instructions to replace the particle filter and the hydrophobic filter.

4. Wait 10 - 15 seconds and observe the display for gas reading. If a reading is observed, allow the reading to stabilize to determine the gas concentration present.

NOTE: Response time increases with the length of the sample hose. Long sample hoses will require more time to show a response at the GX-6000. The maximum sample hose length recommended for the GX-6000 is 50 feet. Consult RKI Instruments, Inc. for longer sample hose lengths.

5. Keep the following in mind:

- Regardless of what gas the PID sensor is calibrated to (factory calibration is to isobutylene), the PID sensor will still detect and respond to a variety of volatile organic compounds (VOCs).
- The PID channel will indicate an upscale reading if one of a variety of combustible gases is present. If %LEL concentrations of one of these combustible gases is present, the PID channel may indicate an overscale reading.
- If concentrations of methane greater than 10% LEL are present in the monitoring environment, the PID channel's reading will be suppressed.
- The PID sensor will also respond to H₂S and NH₃. If H₂S or NH₃ is present, the PID channel may indicate an upscale reading depending on the concentration present.

6. If a gas alarm occurs, take appropriate action. See “Responding to Alarms” on page 35.

Using Optional Sample Hoses

The standard sample hose for the GX-6000 is 3 feet long. Optional sample hoses and probes with longer hoses are available from 5 - 50 feet in 5 foot increments (see “Chapter 7: General Parts List” on page 109). If you are considering using a hose and probe with a longer hose, keep in mind that a longer hose will increase the GX-6000's response time and the flowrate may decrease close to the low flow alarm point.

CAUTION: *Sample hose lengths of more than 50 feet are not recommended for the GX-6000 because of flow rate reduction and increased response time. Consult RKI Instruments, Inc. for hose lengths longer than 50 feet.*

The chart below illustrates how response time is affected by the sample hose length.

Table 4: GX-6000 Response Time vs. Sample Hose Length

Hose Used	Typical Time to 90% of Response (T90)
Probe & 3 Foot Hose (standard)	10 seconds
Probe & 10 Foot Hose	15 seconds
Probe & 30 Foot Hose	30 seconds
Probe & 50 Foot Hose	40 seconds

Snap Log Mode

The snap logging function in Snap Log Mode allows the user to record data at a specific time and have it saved to the data logger. The data is assigned a snap log ID and is saved with the station ID that was in use when the data was taken.

To enter Snap Log Mode and record snap log data:

1. While the unit is in Measuring Mode, press and hold the SHIFT ▼ (PANIC) button, then press and hold the ▲AIR button and hold both until you hear a beep. The unit will cycle through the following screens.

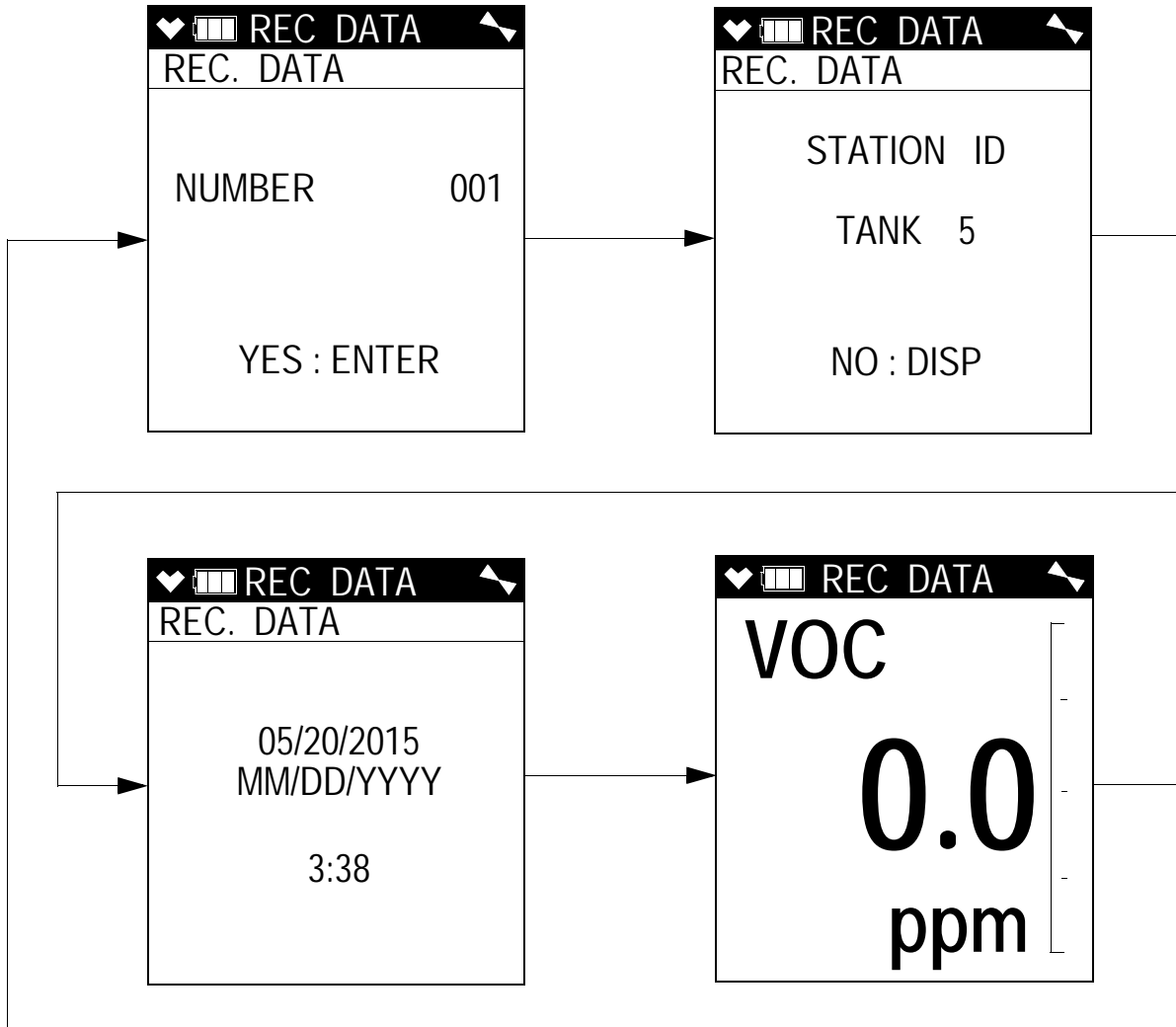

The first screen displays what snap log ID will be given to this particular set of data and that you should press the POWER ENTER button to save a set of snap log data. The snap log ID number increases sequentially with each set of snap log data taken. The second screen displays what Station ID will be associated with this snap log and that you should press the DISP/LOCK button to exit Snap Log Mode without saving a set of snap log data. The third screen displays the year, month, day, and time of the snap log. The fourth screen displays the current gas reading.

NOTE: If the GX-6000 detects an alarm condition while in Snap Log Mode, it will automatically exit Snap Log Mode and return to Measuring Mode. You may then reenter Snap Log Mode and take snap logs while the instrument is still in alarm.

2. You can change the Station ID to be used with the snap log by pressing the SHIFT ▼ (PANIC) button and then pressing the DISP/LOCK button. The Station ID Select Screen will appear and the current Station ID will be flashing.

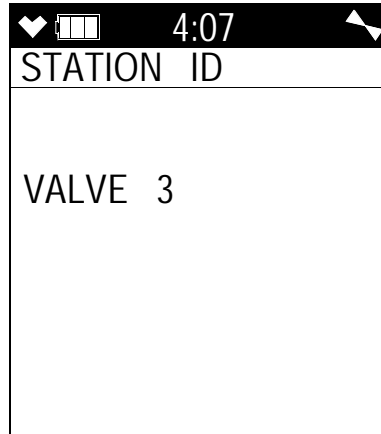

3. Use the ▲AIR and SHIFT ▼ (PANIC) buttons to scroll to the desired Station ID, then press and release the POWER/ENTER button to return to the Snap Logging Screen sequence.
To return to the Snap Logging Screen sequence without changing the Station ID, press and release the DISP/LOCK button.
4. To take a snap log of the current gas reading, press and release the POWER/ENTER button. The unit will display SAVED along the bottom of the screen before returning to the Snap Logging Screen sequence.
To exit Snap Log Mode without taking a snap log or when you are finished recording snap logs, press and release the DISP/LOCK button. The unit will immediately return to the Measuring Mode Screen.
The data recorded in Snap Log Mode can be viewed in Display Mode. See “Viewing Snap Logger Data” on page 52 for more information.

Measuring Mode, Alarms

This section covers alarm indications in Measuring Mode. It also describes how to reset the GX-6000 after an alarm has occurred and how to respond to an alarm condition.

NOTE: False alarms may be caused by radio frequency (RF) or electromagnetic (EMI) interference. Keep the GX-6000 away from RF and EMI sources such as radio transmitters or large motors.

Alarm Indications

The GX-6000 buzzer will sound an alarm, the LEDs will flash, and the vibrator will pulse when any sort of alarm condition or failure is encountered.

NOTE: If an alarm condition occurs while you are in Display Mode, the GX-6000 will automatically bring up the alarm screen instead.

The table below summarizes the types of alarms produced by the GX-6000 and their indications.

None of the Man Down alarm indications will happen if **MAN DOWN** is set to **OFF** in Maintenance Mode (factory setting).

Table 5: Alarm Types and Indications

Alarm Type	Visual Indications	Other Indications
Low Alarm Concentration of gas rises above the Low Alarm setting.	<ul style="list-style-type: none">• Display alternates between gas reading and AL1• Alarm LED arrays flash in circle sequence once per second• Backlight turns on	<ul style="list-style-type: none">• High-low tone sounding twice per second• Vibrator pulses once per second
High Alarm Concentration of gas rises above the High Alarm setting.	<ul style="list-style-type: none">• Display alternates between gas reading and AL2• Alarm LED arrays flash in circle sequence twice per second• Backlight turns on	<ul style="list-style-type: none">• High-low tone sounding four times per second• Vibrator pulses twice per second
TWA or STEL Concentration of high range VOC rises above the TWA or STEL alarm setting.	<ul style="list-style-type: none">• Display alternates between gas reading and TWA or STEL• Alarm LED arrays flash in circle sequence once per second• Backlight turns on	<ul style="list-style-type: none">• High-low tone sounding twice per second• Vibrator pulses once per second
Over Range	<ul style="list-style-type: none">• Display alternates between OVER displayed where the gas reading normally is and OVER displayed where the reading units normally are• Alarm LED arrays flash in circle sequence twice per second• Backlight turns on	<ul style="list-style-type: none">• High-low tone sounding four times per second• Vibrator pulses twice per second

Table 5: Alarm Types and Indications

Alarm Type	Visual Indications	Other Indications
<p>Low Flow</p>	<ul style="list-style-type: none"> • The display indicates FAIL LOW FLOW • Alarm LED arrays flash once per second • Backlight turns on 	<p>Double pulsing tone once per second</p>
<p>Low Battery Warning</p>	<ul style="list-style-type: none"> • The last bar in the battery icon disappears and the battery icon starts flashing 	<p>None</p>
<p>Dead Battery Alarm</p>	<ul style="list-style-type: none"> • Gas reading disappears and FAIL BATTERY appears at the top of the screen • Alarm LED arrays flash once per second 	<p>Double pulsing tone once per second</p>
<p>Sensor Failure</p>	<ul style="list-style-type: none"> • SENSOR appears at the top of the screen and FAIL appears under the gas name. • Alarm LED arrays flash once per second 	<p>Double pulsing tone once per second</p>
<p>Clock Failure</p>	<ul style="list-style-type: none"> • FAIL CLOCK appears at the top of the screen • Alarm LED arrays flash once per second 	<p>Double pulsing tone once per second</p>
<p>System Failure</p>	<ul style="list-style-type: none"> • FAIL SYSTEM appears at the top of the screen and an error code displays below it • Alarm LED arrays flash once per second 	<p>Double pulsing tone once per second</p>
<p>Man Down Warning 1 The WARNING 1 TIME defined in Maintenance Mode has passed since the instrument detected movement.</p>	<ul style="list-style-type: none"> • Alarm LED arrays flash once per second 	<p>Single pulsing tone once per second</p>
<p>Man Down Warning 2 The WARNING 2 TIME defined in Maintenance Mode has passed since the instrument detected movement.</p>	<ul style="list-style-type: none"> • Alarm LED arrays flash twice per second 	<p>Single pulsing tone twice per second</p>
<p>Man Down Alarm The ALARM TIME defined in Maintenance Mode has passed since the instrument detected movement.</p>	<ul style="list-style-type: none"> • MAN DOWN flashes at top of screen in place of time • Alarm LED arrays flash in circle sequence twice per second 	<ul style="list-style-type: none"> • High-low tone sounding twice per second • Vibrator pulses twice per second

Table 5: Alarm Types and Indications

Alarm Type	Visual Indications	Other Indications
<p>Panic User presses and holds the SHIFT ▼ (PANIC) button.</p>	<ul style="list-style-type: none"> • Screen unaffected for 5 seconds before alarm starts • MAN DOWN flashes at top of screen in place of time • Alarm LED arrays flash in circle sequence twice per second • Backlight turns on 	<ul style="list-style-type: none"> • Single pulsing tone twice per second for 5 seconds before alarm starts • High-low tone sounding twice per second • Vibrator pulses twice per second

Responding to Alarms

This section describes response to gas, over range, battery, sensor failure, clock failure, system failure, man down, and panic alarms.

Responding to Gas Alarms

1. Determine which gas alarm has been activated.
2. Follow your established procedure for an increasing gas condition.
3. Reset or silence the alarm as necessary or allowed. Table 6 below summarizes resetting and silencing alarms for all **ALARM LATCHING** and **ALARM SILENCE** combinations that are possible. See “Updating the Alarm Latching Setting (ALARM LATCHING)” on page 127 and “Updating the Alarm Silence Setting (ALARM SILENCE)” on page 127 for further descriptions of these parameters.

Table 6: Resetting and Silencing Alarms

	ALARM LATCHING: LATCHING	ALARM LATCHING: SELF RESET
<p>ALARM SILENCE: ON</p>	<p>(factory setting)</p> <ul style="list-style-type: none"> • Press and release the RESET button to silence the buzzer. • If the gas concentration was still above the alarm level when the button was pressed, the LED arrays continue to flash, the vibrator continues to pulse, and the GX-6000 continues to display the current alarm level. • The gas reading must fall below an alarm setting before you can reset the alarm, the LEDs, and the vibrator using the RESET button. 	<ul style="list-style-type: none"> • Press and release the RESET button to silence the buzzer. • The RESET button will not reset the alarm. • Alarm, LEDs, and vibrator will automatically reset when gas reading falls below an alarm setpoint.
<p>ALARM SILENCE: OFF</p>	<ul style="list-style-type: none"> • RESET button will not silence buzzer. • The gas reading must fall below an alarm setting before you can reset the alarm condition using the RESET button. 	<ul style="list-style-type: none"> • RESET button will not silence or reset alarm. • Alarm condition will automatically reset when gas reading falls below an alarm setpoint.

Responding to an Over Range Alarm

WARNING: *An over range condition may indicate an extreme combustible gas concentration. Confirm a normal condition with a different GX-6000 or with another gas detecting device.*

CAUTION: *A high off-scale reading may indicate an explosive concentration.*

PRUDENCE: *Des lectures élevées hors échelle peuvent indiquer une concentration explosive.*

1. Follow your established procedure for an extreme gas condition.
2. Reset the alarm using the RESET button once the alarm condition has cleared.
3. Calibrate the GX-6000 as described in “Chapter 4: Calibration Mode” on page 58.
4. If the over range condition continues or if you are not able to successfully calibrate the unit, you may need to replace the sensor.
5. If the over range condition continues after you have replaced the sensor, contact RKI Instruments, Inc. for further instructions.

Responding to Battery Alarms

WARNING: *The GX-6000 is not operational as a gas monitoring device during a dead battery alarm. Take the GX-6000 to a non-hazardous area and replace or recharge the batteries as described in “Replacing or Recharging the Batteries” on page 85.*

The GX-6000 is fully functional during a low battery warning. However, only a limited amount of operating time remains, approximately 1 - 2 hours. The amount of time depends on how often the LCD backlight is used and how often the unit is responding to alarm conditions. Recharge the Li-ion battery pack or replace the alkaline batteries as soon as possible as described in “Replacing or Recharging the Batteries” on page 85.

NOTE: Alarms and the LCD back light consume battery power and reduce the amount of operating time remaining.

Responding to a Sensor Failure Alarm

1. Try calibrating the sensor as described in “Chapter 4: Calibration Mode” on page 58 before replacing it.
2. If the sensor failure continues, replace the sensor as described in “Replacing the PID Sensor” on page 94.
3. If the sensor failure condition continues after you have replaced the sensor, contact RKI Instruments, Inc. for further instructions.

Responding to Clock Failure Alarms

A clock failure alarm occurs if the unit's internal clock malfunctions.



1. Press and release the RESET button to continue into Measuring Mode.

CAUTION: *There will be no datalogging function if you operate the instrument after a clock failure.*

2. Attempt to change the date using the **DATE** menu item in Maintenance Mode. See “Setting the Date and Time (DATE)” on page 118.
3. If the date cannot be set correctly, contact RKI Instruments, Inc. as soon as possible.

Responding to System Failure Alarms

1. If a system failure occurs, the system failure screen will display an error code as shown below:

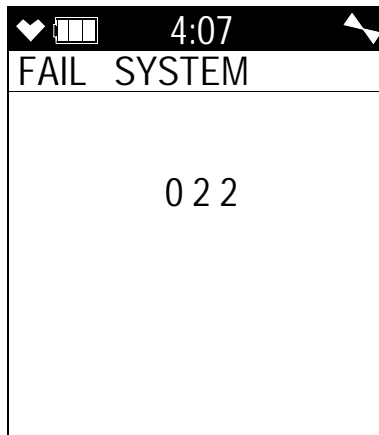

2. The error code meanings are shown in the table below:

Table 7: Error Code Explanation

Error Code	Explanation
000	ROM failure
010	RAM failure
021	FRAM failure
022	FLASH memory failure

3. If the error code is anything but 022 as shown above, the instrument cannot be used. Contact RKI Instruments, Inc. as soon as possible.

If the error code is 022, you may press and release the RESET button to continue into Measuring Mode if the instrument must be used temporarily.

CAUTION: *There will be no datalogging function if you operate the instrument after a 022 system failure. Contact RKI Instruments, Inc. as soon as possible.*

Responding to a Man Down Warning 1 and Warning 2

The Man Down Warning 1 and Warning 2 alarms occur after the **WARNING 1 TIME** and **WARNING 2 TIME**, respectively, has passed since the last movement of the instrument. See “Updating the WARNING 1 TIME Setting” on page 133 and “Updating the WARNING 2 TIME Setting” on page 133 for instructions to change these values.

1. Follow your established procedure for a man down warning.
2. To silence the alarm and reset the Man Down clock, move the instrument or press and release the RESET button.

Responding to a Man Down Alarm

The Man Down Alarm alarms occur after the **ALARM TIME** has passed since the last movement of the instrument. See “Updating the ALARM TIME Setting” on page 133 for instructions to change this value.

1. Follow your established procedure for a man down alarm.
2. To silence the alarm and reset the Man Down clock, press and release the RESET button. Moving the instrument will not reset the alarm or Man Down clock.

Responding to a Panic Alarm

If the user is in a dangerous situation or feels that others must be alerted to any sort of problem, holding the SHIFT ▼ (PANIC) button will initiate a panic alarm.

1. Press and release the RESET button to silence and reset the alarm.

Display Mode

Two other operating modes are accessible when the GX-6000 is in Measuring Mode. They are Display Mode and Calibration Mode. This section describes using the GX-6000 in Display Mode. See Table 8 below for a list of Display Mode's menu items, a short description of each item, and the page number for further description.

Table 8: Display Mode Items

Menu Item (page number)	Description
SELECT PID LIST (pg.40)	Define the PID channel's gas name
PEAK (pg.42)	View and clear the peak reading
STEL (pg.43)	View the STEL reading (<i>high range PID only</i>)
TWA (pg.44)	View the TWA reading (<i>high range PID only</i>)
ALARM POINTS (pg.44)	View the alarm points
OPERATION TIME (pg.46)	View the time in operation
DATE AND BATTERY (pg.46)	View the date/time, battery voltage, and battery type
LOG REMAIN (pg.47)	View the log time remaining
LOG CLEAR (pg.47)	Clear the log data
PUMP OFF (pg.49)	Turn the pump on or off (if the PUMP OFF DISP item in Maintenance Mode is set to ON)
USER ID (pg.50)	Select the user ID (if the ID DISPLAY item in Maintenance Mode is set to ON)
STATION ID (pg.51)	Select the station ID (if the ID DISPLAY item in Maintenance Mode is set to ON)
REC. DATA DISP (pg.52)	View snap logger data
PEAK BAR (pg.54)	Turn the peak bar function on or off
GAS DISP (pg.54)	N/A
INVERT SELECT (pg.54)	Turn the LCD flip function on or off
LCD BACKGROUND (pg.55)	Reverse the black/white of the LCD
LANGUAGE (pg.56)	Change the instrument's language back to English (only appears if the language has been changed to something other than English)

Tips for Using Display Mode

- To enter Display Mode and scroll from one menu item to the next or skip an item when a question is asked, press and release the DISP/LOCK button.
- To enter an item, press and release the POWER/ENTER button.
- To change a flashing parameter, use either the ▲AIR button or SHIFT ▼ (PANIC) button.

- To return to Measuring Mode from the top level of any menu item, press and release the RESET button.

NOTE: With the exception of the Pump Off Screen, each screen displays for 20 seconds. If you do not press a button within 20 seconds, the GX-6000 automatically returns to Measuring Mode. If the Pump Off Screen is used to turn the instrument's pump off, the Pump Off Screen will display until you turn the pump back on.

PID Gas Name Screen

The standard PID channel is configured for and calibrated to isobutylene. If calibration to a different gas is required for an application, the PID channel can also be configured for other gases. Regardless of what gas the PID sensor is configured for and calibrated to, the sensor will still detect and respond to a variety of volatile organic compounds (VOCs).

If you configure the instrument for another gas, the instrument will retain that configuration until you change it again. Turning the instrument off and on does not change this setting.

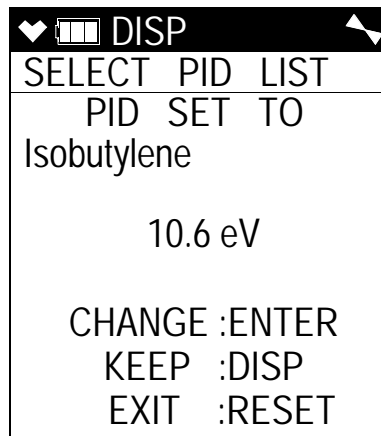

1. With the PID Gas Name Screen displayed, press and release the POWER/ENTER button. The top level of the PID Gas Name List will be displayed and the cursor will be next to the letter corresponding to the first letter of the current setting. In the example below, the PID channel is configured for isobutylene so the cursor is next to "I". Each letter has a list of gas names behind it.

At the top of the letter list, there is a User List item and a Recent List item. The User List can hold 30 gas names. See "Appendix E: Creating a PID User List" on page 173 for instructions to edit the User List. The Recent List can hold up to 8 gas names and is made up of the 8 most recently used gas names. The Recent List is not user editable.

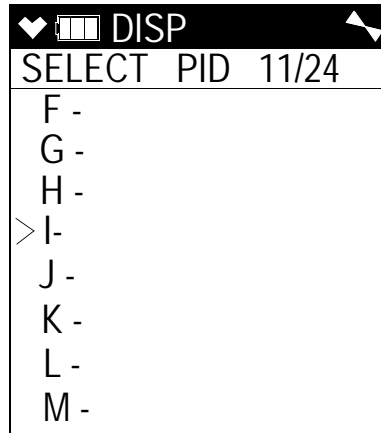

2. Use the ▲AIR and SHIFT ▼(PANIC) buttons to scroll through the letter and list options. To view the gas names behind a letter, User List, or Recent List, press and release the POWER/ENTER button when the cursor is next to the desired letter.

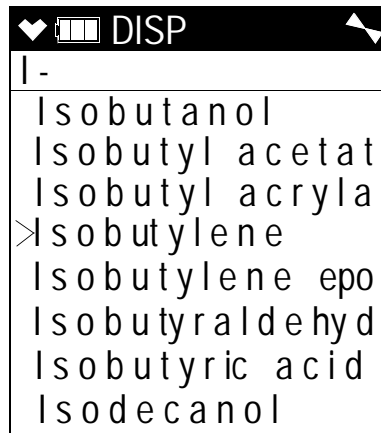

3. Use the ▲AIR and SHIFT ▼(PANIC) buttons to scroll through the gas names.

- To view the information for each gas name, press and release the POWER/ENTER button when the cursor is next to the desired gas name. The number in the upper left corner is the gas's number in relation to all other gas names that are stored in the GX-6000. The chemical formula is displayed next to the gas number. The response factor relative to isobutylene is listed on the second line. The gas name is listed on the third line.

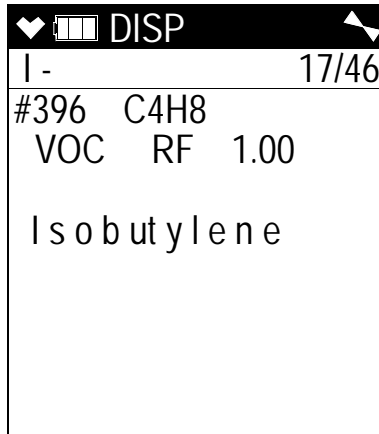

- To select a gas name, press and release the POWER/ENTER button while you are viewing the parameters. The selection will be in effect until you change it again. To return to the gas name list without saving any changes, press and release the DISP/LOCK button.
- To return to the top level PID Gas Name List that has all of the letter choices, press and release the DISP/LOCK button.
- To return to the PID Gas Name Screen, press and release the DISP/LOCK button one more time.

Peak Screen

The peak screen displays the highest concentration detected since the GX-6000 was turned on. The peak reading is stored in the GX-6000's memory until a higher level is detected, the peak reading is cleared, or the GX-6000 is turned off.

The lunch break feature enables the GX-6000 to save the peak reading when it is turned off so it can continue them when it is turned on again. See "Turning On the GX-6000" on page 20.

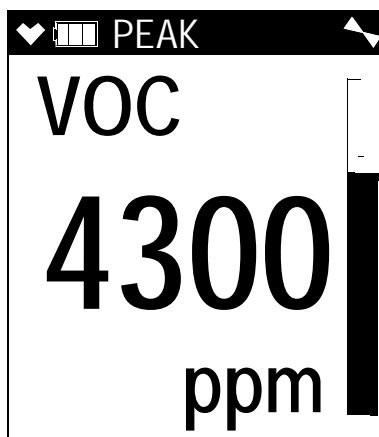

To clear the peak reading, do the following:

- 1 . With the Peak Screen displayed, press and hold the RESET button. The following screen sequence will occur.

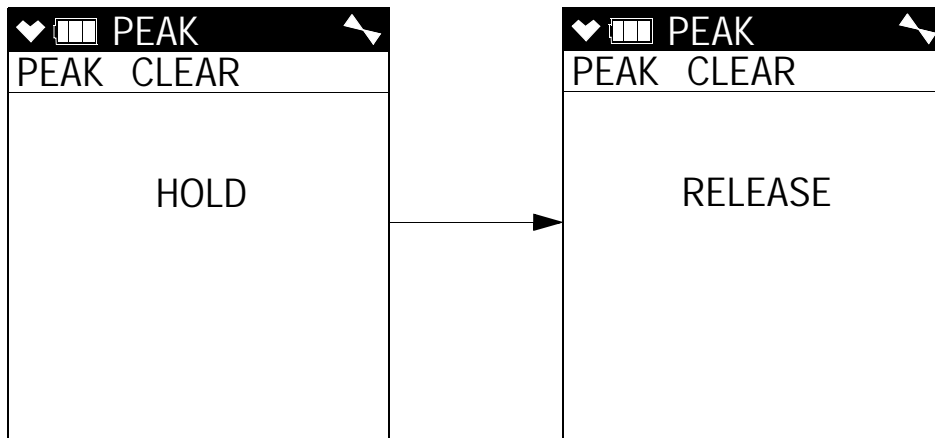

- 2 . Release the RESET button. The peak reading will be reset and the unit will return to the Peak Screen.

If you do not want to clear the peak reading, release the RESET button before the above screen sequence occurs. The unit will return to the Peak Screen.

STEL Screen

The STEL Screen displays the short term exposure limit (STEL) reading (high range PID only). The STEL reading is the average reading *over the last 15 minutes*.

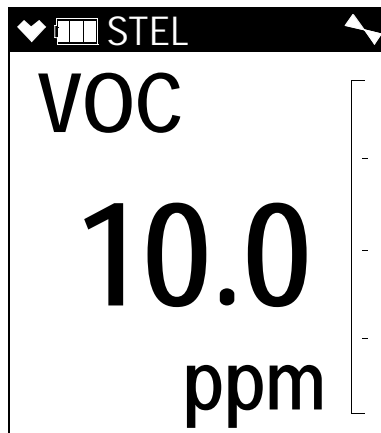

TWA Screen

The TWA Screen displays the time weighted average (TWA) reading (high range PID only).

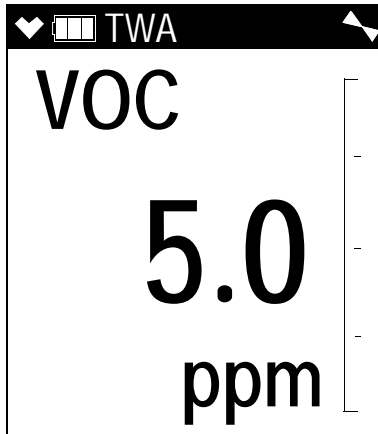

The TWA reading is the average reading *over the last 8 hours*. If 8 hours have not elapsed since the last time the TWA reading was cleared, the average is still calculated over 8 hours. The missing time is assigned a 0 value for readings. If **LUNCH BREAK** is set to **OFF**, the TWA is cleared when the GX-6000 is turned off.

If **LUNCH BREAK** is set to **ON**, the GX-6000 will remember the TWA reading when it is turned off so it can continue it when it is turned on again. See “Turning On the GX-6000” on page 20.

View Alarm Settings Screen

The View Alarm Settings Screen gives you the option to view the gas alarm settings.

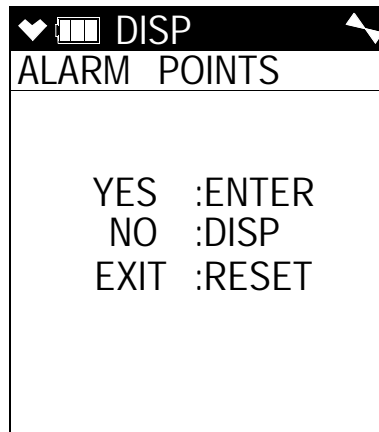

To view the gas alarm settings, do the following:

1. With the View Alarm Settings Screen displayed, press and release the POWER/ENTER button. The Full Scale Settings screen will appear. Use the ▲AIR and SHIFT ▼ (PANIC) buttons to scroll through the Warning, Alarm, STEL (high range PID only), and TWA (high range PID only) settings.

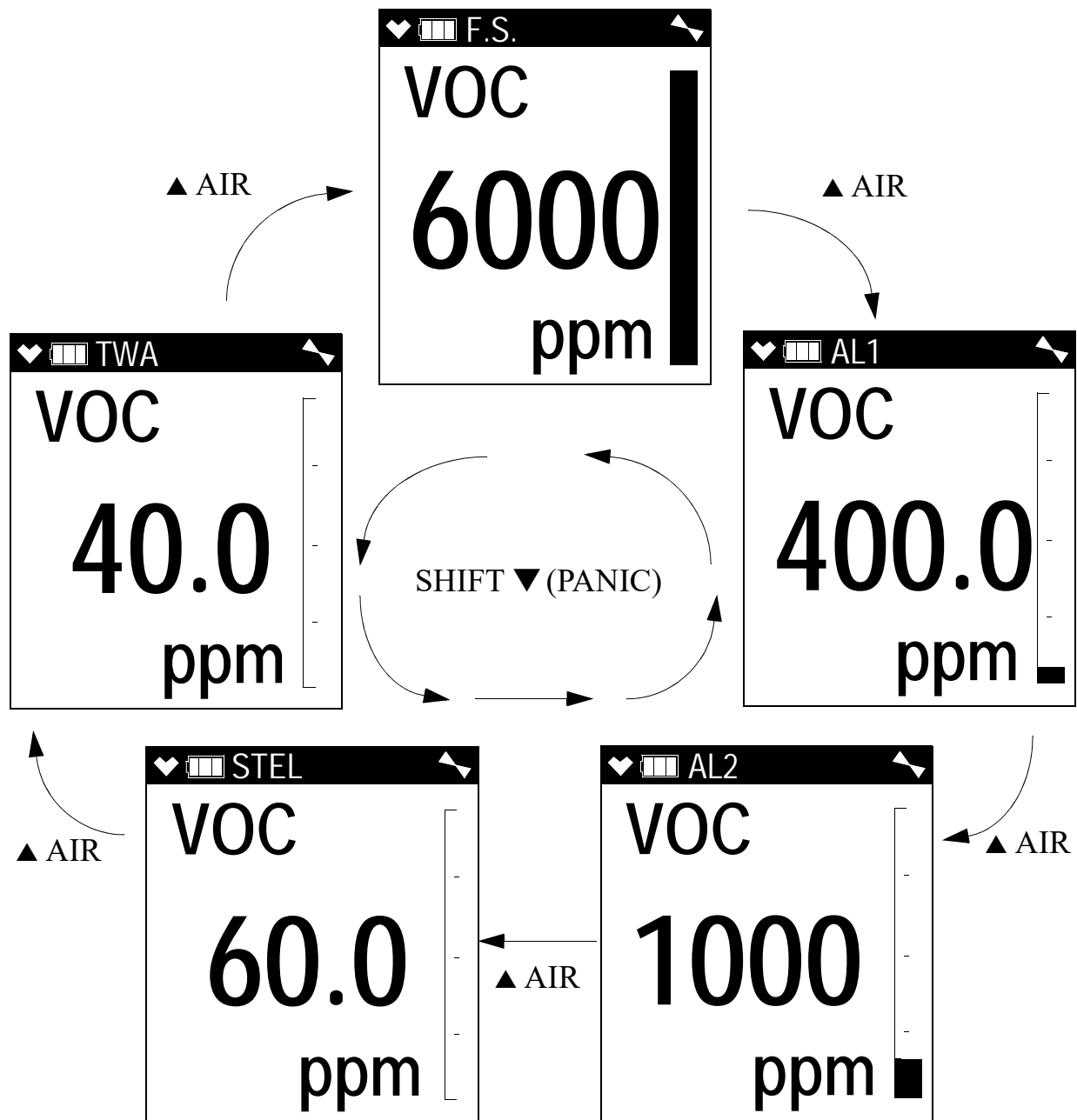

2. Pressing and releasing the POWER/ENTER button while in a settings screen will cause the instrument to simulate that condition. The buzzer, LED's, and vibration will activate. Press and release the POWER/ENTER button again to stop the simulated alarm.
3. Press and release the DISP/LOCK button to return to the View Alarm Settings Screen.

Time in Operation Screen

The Time In Operation Screen displays the length of time since the GX-6000 was turned on if the lunch break feature is turned off. With **LUNCH BREAK** set to **OFF**, the time in operation is reset when the GX-6000 is turned off. See “Updating the Lunch Break Setting (LUNCH BREAK)” on page 129 for a description of the lunch break feature.

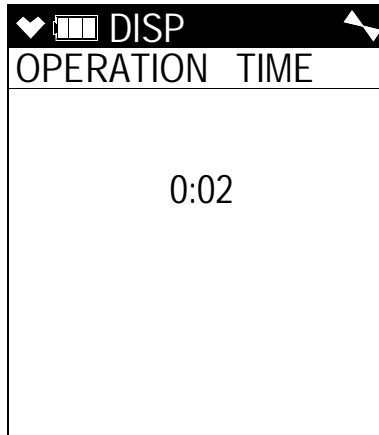

If **LUNCH BREAK** is set to **ON**, the time in operation will only be reset if you do not choose to resume the peak and TWA measurements when the GX-6000 is turned on in the Lunch Break Screen described in Step 3 on page 21 in “Turning On the GX-6000”. If you choose to resume the peak and TWA measurements during startup, the GX-6000 will include the time in operation when the unit was last turned off in the current time in operation.

Date/Time, Battery Voltage Screen

The Battery Voltage Screen displays the current battery voltage. Fully charged alkaline batteries typically indicate around 6.0 volts; a fully charged Li-ion battery pack typically indicate 4.1 volts. This screen also displays during the startup sequence.

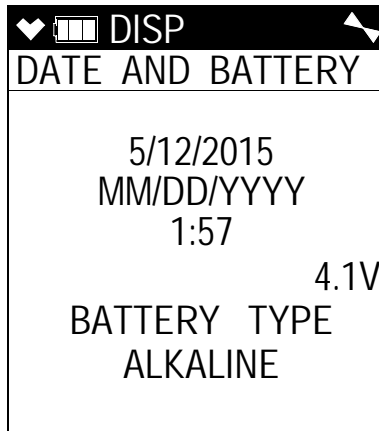

Log Time Remaining Screen

The Data Logging screen displays the time remaining until the data logger memory is full.

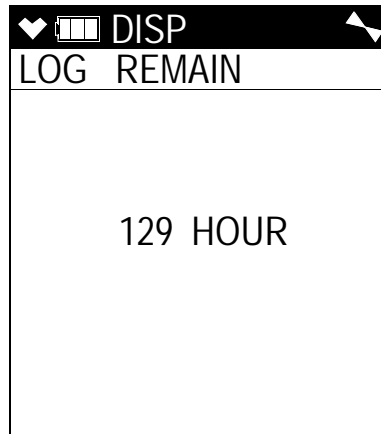

LOG CLEAR Screen

CAUTION: *Once you clear the data logger, you cannot retrieve any data previously stored in the data logger.*

The **LOG CLEAR** screen asks if you want to clear the data logger memory.

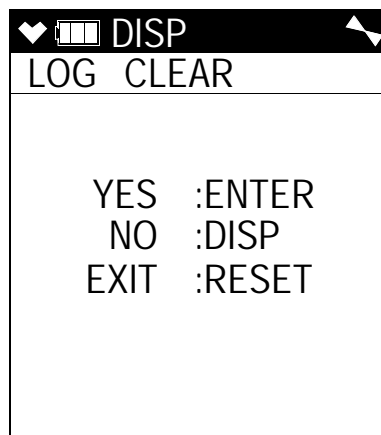

To continue through Display Mode without clearing the log data, press and release the DISP/LOCK button.

To clear the data logger memory, do the following:

- 1 . With the **LOG CLEAR** Screen displayed, press and release the POWER/ENTER button. The following screen appears asking you to confirm that you want to clear the data logger memory.

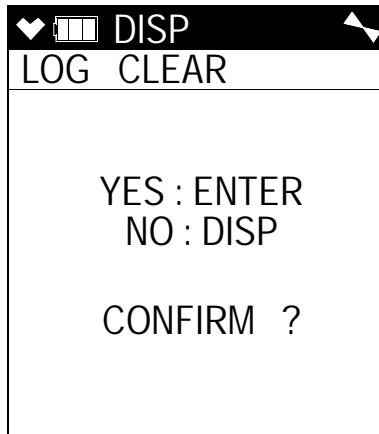

- 2 . If you do not want to clear the data logger memory, press and release the DISP/LOCK button. The unit will return to the **LOG CLEAR** screen in Display Mode.
- 3 . If you want to clear the data logger memory, press and release the POWER/ENTER button. The unit will display the following screen as it clears the data.

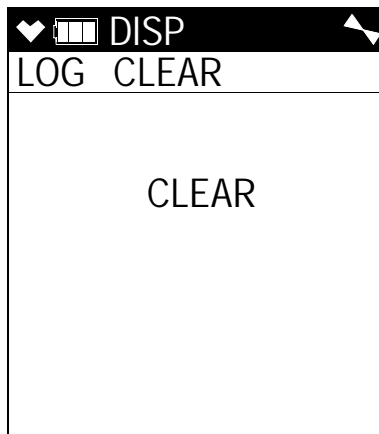

- 4 . When the instrument has cleared the data, it will return to the **LOG CLEAR** screen in Display Mode.

Pump Off Screen

WARNING: *The GX-6000 is not a gas monitoring device while the pump is off.*

NOTE: The item appears in Display Mode only if the **PUMP OFF DISP** menu item in Maintenance Mode is turned **ON**. The factory setting for **PUMP OFF DISP** is **OFF**.

This feature can be used to conserve battery life if there is a significant period of time until the next gas monitoring task, but you do not want to wait for the warm-up sequence to complete if you turn the instrument off and on again.

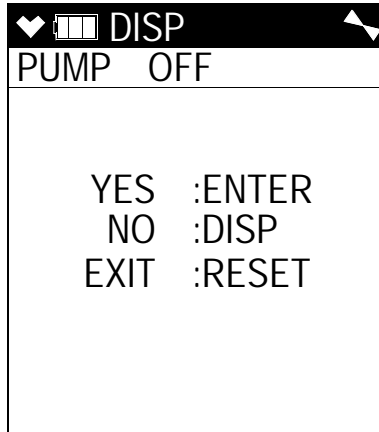

1. In this screen, press and release the POWER/ENTER button to turn the pump off. The fan symbol in the upper right corner will disappear. Once the pump is off, you cannot exit this screen and return to Measuring Mode or continue in Display Mode until you turn the pump back on.

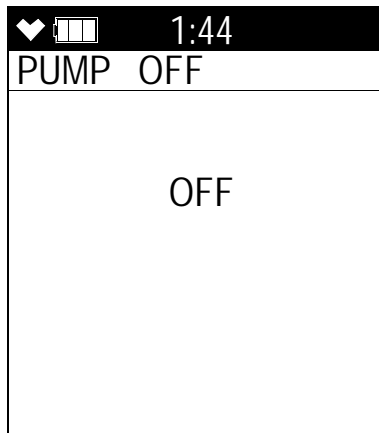

2. To turn the pump back on and continue in Display Mode or return to Measuring Mode, press and release the DISP/LOCK button.

Select User ID Screen

This screen only appears in Display Mode if the **ID DISPLAY** item in Maintenance Mode is set to **ON**. Use this screen to select a user ID from the user ID list in the GX-6000's memory. The current user ID is displayed. A user ID can be up to 16 characters long. The GX-6000 can store up to 128 user IDs.

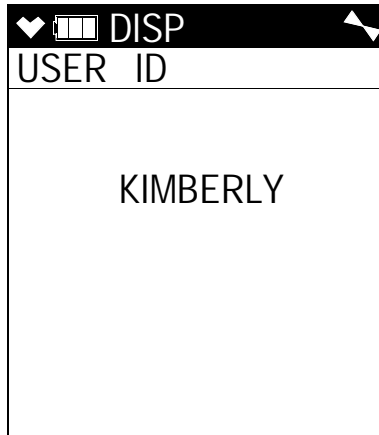

The user ID provides a way to identify the GX-6000 user during a data logging session. If the user ID is changed during an operating session, a new data session is initiated with the new user ID attached to it. This allows you to change the user ID during operation and have each user ID that was used during an operating session saved for the corresponding data. See the GX-6000 Data Logger Management Program Operator's Manual for a detailed description of data logging and the user ID.

The user ID list cannot be edited using the GX-6000 user interface. The GX-6000 Maintenance Data Loader Program is required to define or change user IDs in the user ID list. For a detailed description of editing the list of user IDs stored in the GX-6000, see the GX-6000 Maintenance Data Loader Program Operator's Manual.

To select a different user ID:

1. With the Select User ID Screen displayed, press and release the POWER/ENTER button. The current user ID will be displayed and it will be flashing.

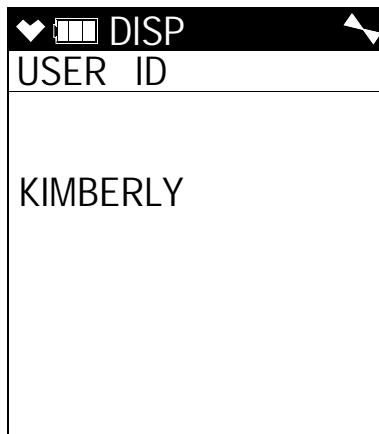

2. Use the **▲AIR** and **SHIFT ▼(PANIC)** buttons to scroll through the available user IDs. The list will wrap around if you get to the top or bottom. Any of the user IDs in the list that have not been changed from the factory setting will be shown as **USER_ID_XXX** where the "XXX" is a number from 001 to 128.

- 3 . When the desired user ID is displayed, press and release the POWER/ENTER button.

NOTE: To exit the selection screen without saving a change, press and release the DISP/LOCK button. You will return to the Select User ID screen without saving the user ID change.

- 4 . The unit will save the selected user ID as the current one and will return you to the Select User ID Screen.

Select Station ID Screen

This screen only appears in Display Mode if the **ID DISPLAY** item in Maintenance Mode is set to **ON**. Use this screen to select a station ID from the station ID list in the GX-6000's memory. The current station ID is displayed. A station ID can be up to 16 characters long. The GX-6000 can store up to 128 station IDs.

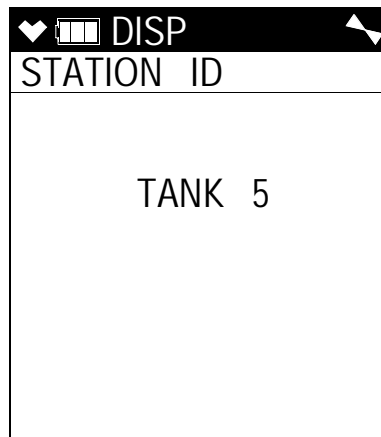

The station ID provides a way to identify a location where monitoring was done during a data logging session. If the station ID is changed during an operating session, a new data session is initiated with the new station ID attached to it. This allows you to change the station ID during operation and have each station ID that was used during an operating session saved for the corresponding data. See the GX-6000 Data Logger Management Program Operator's Manual for a detailed description of data logging and the station ID.

The station ID list cannot be edited using the GX-6000 user interface. The GX-6000 Maintenance Data Loader Program is required to define or change station IDs in the station ID list. For a detailed description of editing the list of station IDs stored in the GX-6000, see the GX-6000 Maintenance Data Loader Program Operator's Manual.

To select a different station ID:

1. With the Select Station ID Screen displayed, press and release the POWER/ENTER button. The current user ID will be displayed and it will be flashing.

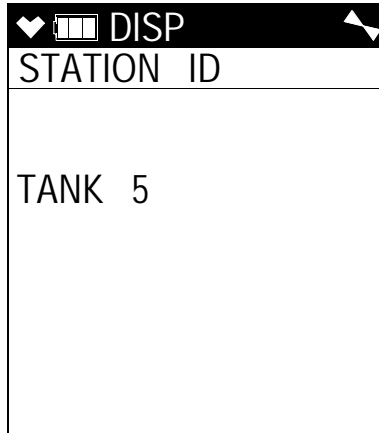

2. Use the ▲AIR and SHIFT ▼(PANIC) buttons to scroll through the available station IDs. The list will wrap around if you get to the top or bottom. Any of the station IDs in the list that have not been changed from the factory setting will be shown as STATION_ID_XXX where the “XXX” is a number from 001 to 128.
3. When the desired station ID is displayed, press and release the POWER ENTER button.

NOTE: To exit the selection screen without saving a change, press and release the DISP/LOCK button. You will return to the Select Station ID screen without saving the station ID change.

4. The unit will save the selected station ID as the current one and return you to the Select Station ID Screen.

Viewing Snap Logger Data

The Snap Logging Screen allows you to view data from previous snap logs. For information on how to use the snap logging feature, see “Snap Log Mode” on page 31.

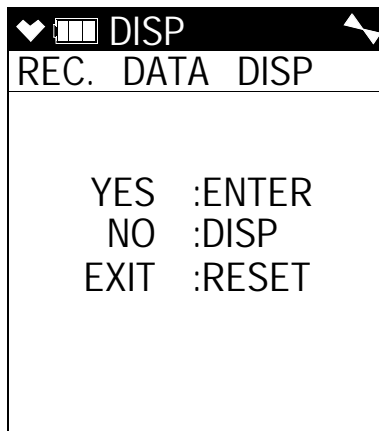

1. With the snap logging screen displayed, press and release the POWER/ENTER button. The screen that appears will depend on whether or not any snap logs have been taken.

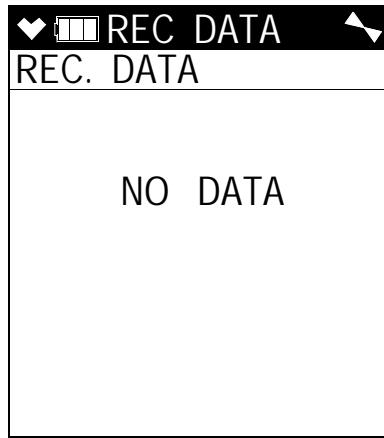

No snap logs taken

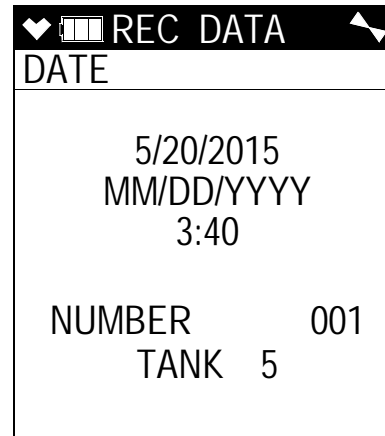

Snap logs taken

2. If snap logs have been taken, the screen indicates the year, month, day, and time that the most recent snap log was taken.

The number near the bottom of the screen indicates the snap log ID number. The first snap log that is taken is given an ID of 001. The next snap log ID is 002. The ID number increases sequentially with each set of snap log data.

The last line of the screen indicates the Station ID that was used for the snap log.

3. Use the ▲AIR and SHIFT ▼(PANIC) buttons to scroll through different snap log IDs.
4. To view the data in a snap log ID, press and release the POWER/ENTER button.

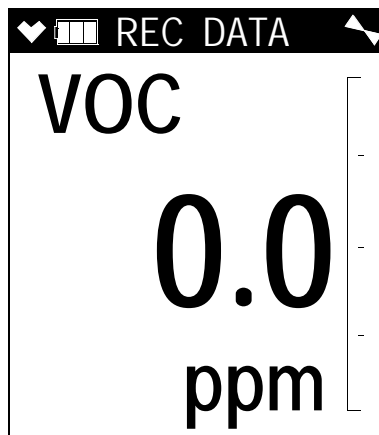

The gas reading that was taken during the snap log is displayed. You can use the ▲AIR and SHIFT ▼(PANIC) buttons to scroll through the different snap logs. The gas reading will change as you view different snap log data but the snap log ID is not visible from this screen. To scroll through the data by viewing the snap log ID number, press and release POWER/ENTER.

5. To return to the Snap Logging Screen, press and release the DISP/LOCK button.

Peak Bar Screen

The Peak Bar Screen allows you to turn the peak bar on or off. If the function is turned on, the peak bar appears along the right side of the gas reading in Measuring Mode and on the Peak Screen in Display Mode. It shows the peak reading in bar graph format.

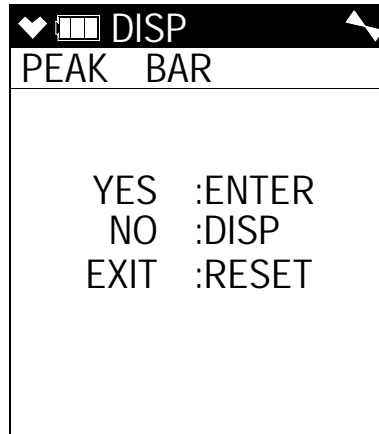

1. With the Peak Bar Screen displayed, press and release the POWER/ENTER button. The current setting will be displayed.
2. Use the ▲AIR and SHIFT ▼(PANIC) buttons to display the desired setting.
3. Press and release the POWER/ENTER button to save the setting and return to the Peak Bar Screen.

To return to the Peak Bar Screen without saving any changes, press and release the DISP/LOCK button.

Gas Display Screen

This menu item does not apply to this version of the GX-6000.

LCD Flip Screen

If **INVERT SELECT** is set to **ON**, the instrument's LCD will automatically flip if the instrument is turned upside down. This allows for the LCD to be read with the instrument right side up or upside down. If desired, holding down the DISP/LOCK button will lock the screen in its current position and keep it from rotating. A **LOCK** symbol will flash at the top of the screen to indicate that the LCD's position is fixed. To unlock the LCD, hold the DISP/LOCK button until the **LOCK** symbol disappears.

NOTE: Even if **INVERT SELECT** is set to **ON**, the screens in Calibration Mode, User Mode, and Maintenance Mode will not flip if the instrument is turned upside down.

If **INVERT SELECT** is set to **OFF**, the instrument's LCD will not flip and can only be read when the instrument is right side up. A **LOCK** symbol will appear at the top of the screen to indicate that the LCD's position is fixed.

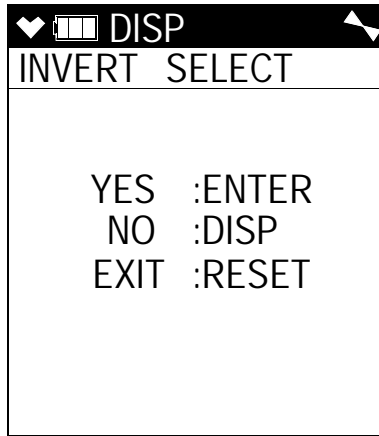

1. With the Gas Display Screen showing, press and release the POWER/ENTER button. The current setting will be displayed.
2. Use the ▲AIR and SHIFT ▼(PANIC) buttons to display the desired setting.
3. Press and release the POWER/ENTER button to return to the LCD Flip Screen.
To return to the LCD Flip Screen without saving any changes, press and release the DISP/LOCK button.

LCD Background Color Flip

With **LCD BACKGROUND** set to **ON**, the LCD colors will flip. The background will be black instead of white and the text will be white instead of black. With **LCD BACKGROUND** set to **OFF** (factory setting), the LCD background will be white and the LCD text will be black.

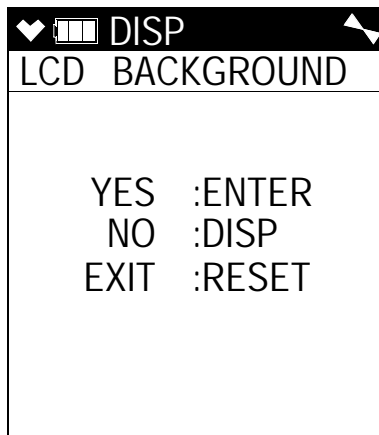

1. With the LCD Background Flip Screen showing, press and release the POWER/ENTER button. The current setting will be displayed.
2. Use the ▲AIR and SHIFT ▼(PANIC) buttons to display the desired setting.
3. Press and release the POWER/ENTER button to return to the LCD Background Flip Screen.
To return to the LCD Background Flip Screen without saving any changes, press and release the DISP/LOCK button.

Language Screen

If the instrument's language is changed to something other than English, the Language Screen will appear in Display Mode. The Language Screen will not appear if the instrument's language is set to English. The Language Screen allows the user to change the instrument's language back to English.

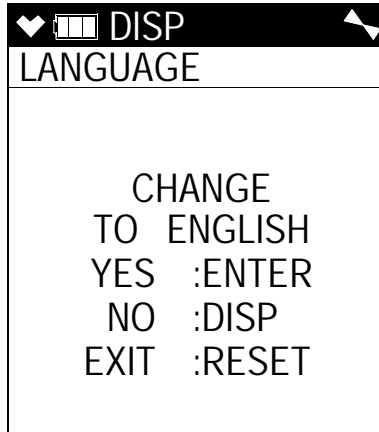

To change the language back to English, do the following:

- 1 . With the Language Screen showing, press and release the POWER/ENTER button. The following screen will appear asking you to confirm that you want to change the language back to English.

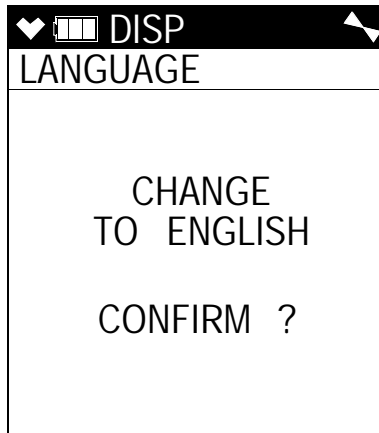

- 2 . Press and release the POWER/ENTER button again to confirm the change. To return to the Language Screen without changing the instrument's language to English, press and release the DISP/LOCK button.

Data Logging

The GX-6000 features the ability to log data to its internal memory and download it to a computer via the infrared communications port on the front of the unit. It logs gas readings in Measuring Mode, alarm data, and calibration data.

NOTE: The data logging function is separate from the snap logging function. For a description of the snap logging function, see “Snap Log Mode” on page 31.

To utilize the GX-6000’s downloading capability, you will need the GX-6000 Data Logger Management Program and a computer with an infrared port or a USB port that runs one of the following operating systems: Windows® 7, Windows® 8, or Windows® 10. If your computer has an infrared port, then no additional accessories are needed to download data from the GX-6000. If your computer does not have an infrared port but does have a USB port, a USB/IrDA adapter cable can be used to download data from the GX-6000 using the USB port. The GX-6000 Data Logger Management Program is available at www.rkiinstruments.com/gx6000. The USB/IrDA adapter cable is also available from RKI Instruments, Inc.

The data logging capacity depends on how often the GX-6000 stores data and how often the GX-6000 is turned on and off. The table below illustrates how much data logging time is available for the various interval times. It assumes that the unit is only turned on once and that there are no alarm occurrences. See “Updating the Data Log Interval Setting (LOG INTERVAL)” on page 134 for instructions on setting the data logging interval time.

Table 9: Data Logging Capacity

Interval Time	Data Logging Time
10 seconds	10 hours
20 seconds	20 hours
30 seconds	30 hours
1 minute	60 hours
3 minutes	180 hours
5 minutes	300 hours
10 minutes	600 hours

For a complete description of the Data Logger Management Program and procedures for downloading data to a computer, see the GX-6000 Data Logger Management Program Operator’s Manual.

Chapter 4: Calibration Mode

Overview

This section describes the GX-6000 in Calibration Mode. In Calibration Mode, you can move through a menu of screens to do the following:

- Perform a fresh air (zero) adjustment
- Perform a span adjustment using auto calibration
- Perform a span adjustment using single calibration
- Perform a bump test

NOTE: You can set up the GX-6000 to alert you during the startup sequence when calibration is due. See “Updating the Calibration Reminder Setting (CAL REMINDER)” on page 120.

The unit should be calibrated periodically. The optimum frequency of calibration depends heavily on how the GX-6000 is used. For example, instruments used daily may need to be calibrated weekly or monthly, while instruments that are used only a few times a year may need to be calibrated before each use. Typical calibration frequencies range from monthly to quarterly.

Calibration Supplies and Equipment

To calibrate the GX-6000, you will need:

- Known calibrating samples of the gas being detected. RKI Instruments, Inc. normally recommends a calibration concentration between 10% and 50% of the full scale value but in this case, RKI Instruments, Inc. recommends a calibration concentration of 10 ppm IBL for the low range sensor and 100 ppm IBL for the high range sensor.
- A demand-flow regulator to provide adequate sample gas flow
- Non-absorbent tubing

WARNING: *If you are using a calibration kit that includes a gas bag and a fixed flow regulator or dispensing valve, do not apply gas directly to the GX-6000 with the regulator or dispensing valve or damage to the pump will result.*

Entering Calibration Mode

To enter Calibration Mode, do the following:

1. Find a fresh-air environment. This is an environment free of toxic or combustible gases and of normal oxygen content (20.9%).
2. While in Measuring Mode, press and hold the SHIFT ▼ (PANIC) button, then press the DISP/LOCK button and release both buttons.
3. If the unit prompts you for the password, enter it by using the ▲AIR and SHIFT ▼ (PANIC) buttons to select each password number and then pressing and releasing POWER/ENTER to enter the number and move on to the next one.

NOTE: You will only be prompted to enter a password if the **PASSWORD** menu item in User Mode is set to **ON**. See “Turning the Password Function On or Off” on page 81 for instructions to update the **PASSWORD** setting and to choose a password.

4. The Calibration Mode Screen displays with the cursor next to **AIR CAL**.

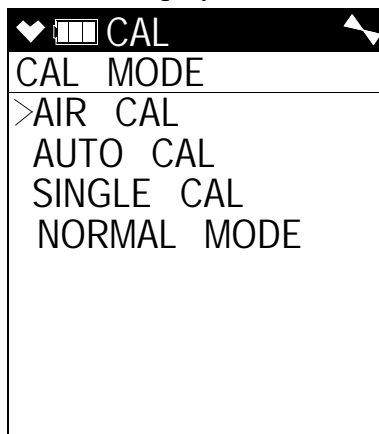

Calibrating Using the Auto Calibration Method

This method is the quickest and easiest method to calibrate the GX-6000. See Table 13 on page 109 for available cylinders. Make sure your calibration cylinder is appropriate for the PID detection range.

Setting the Fresh Air Reading

1. Find a fresh-air environment. This is an environment free of toxic or combustible gases and of normal oxygen content (20.9%).
2. While in Measuring Mode, press and hold the SHIFT ▼ (PANIC) button, then press the DISP/LOCK button and release both buttons.
3. If the unit prompts you for the password, enter it by using the ▲AIR and SHIFT ▼ (PANIC) buttons to select each password number and then pressing and releasing POWER/ENTER to enter the number and move on to the next one.

NOTE: You will only be prompted to enter a password if the **PASSWORD** menu item in User Mode is set to **ON**. See “Turning the Password Function On or Off” on page 81 for instructions to update the **PASSWORD** setting and to choose a password.

4. The Calibration Mode Screen displays with the cursor next to **AIR CAL**.

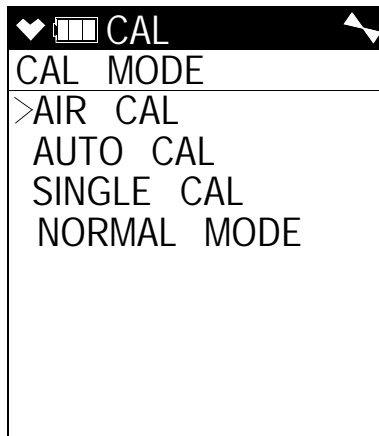

5. Press and release the POWER/ENTER button. The Fresh Air Reading screen will display.

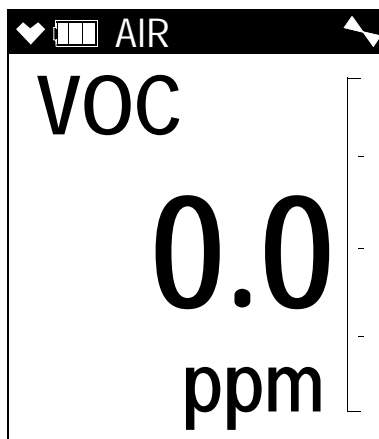

6. If you suspect any low-level VOC background in the area, you will need to use the VOC zero filter.
- Remove the plug from each end of the VOC zero filter.
 - Attach the VOC zero filter to the inlet fitting or probe. The filter does not have a preferred flow direction.
 - Let the instrument draw through the VOC zero filter for 1 minute before continuing.
7. To continue with the fresh air adjustment, press and hold the ▲AIR button. If you do not want to continue, press and release the DISP/LOCK button and the unit will return to the Calibration Mode Screen.

8. The GX-6000 will indicate that it is adjusting the zero reading for a few seconds and then it will prompt you to release the ▲AIR button.

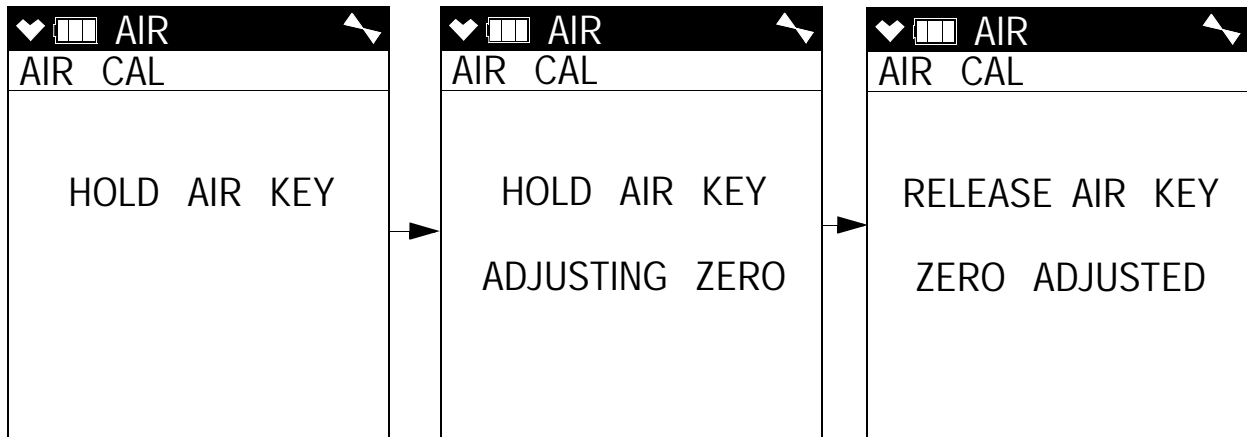

9. Release the ▲AIR button. The fresh air adjustment will finish, the fresh air reading will be displayed momentarily, and then the instrument will return to the Calibration Mode Screen.

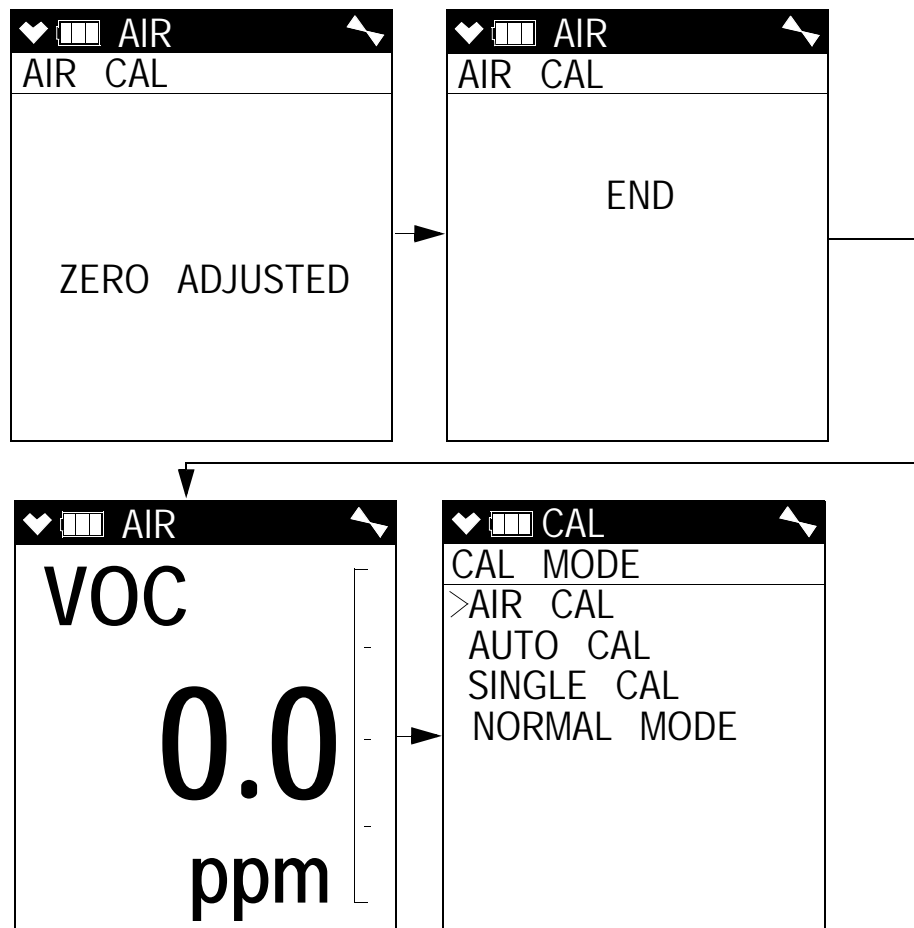

10. If the VOC zero filter was used, remove the filter from the GX-6000's inlet fitting or probe. Reinstall the plugs on each end of the filter.

Performing a Span Adjustment in Auto Calibration

1. Install the demand flow regulator onto the calibration cylinder.
2. Connect the sample tubing to the demand flow regulator.
3. Install the sample hose and probe on the GX-6000 inlet fitting. Make sure the probe's two halves are tightened firmly together to avoid leaks that can affect the calibration. See Figure 21, "Replacing the Particle Filter and Hydrophobic Filter Disk" on page 93 for an illustration of the internal parts of the probe.
4. Move the cursor next to the **AUTO CAL** menu item by using the **▲AIR** or **SHIFT ▼ (PANIC)** button.

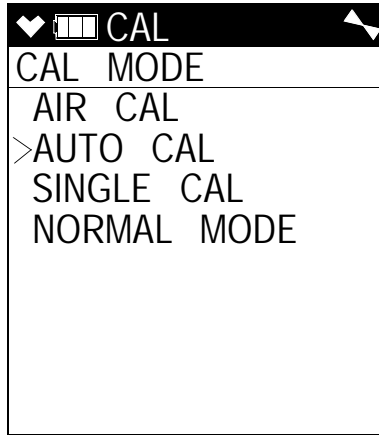

5. Press and release the **POWER/ENTER** button to display the Auto Cal Menu.

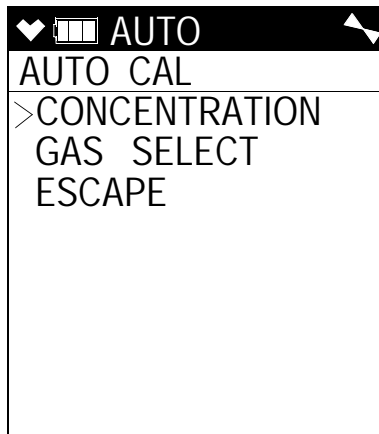

- To check or update the gas concentration, use the ▲AIR and SHIFT ▼(PANIC) buttons to put the cursor next to **CONCENTRATION** and press and release the POWER/ENTER button to display the Calibration Gas Values Screen.

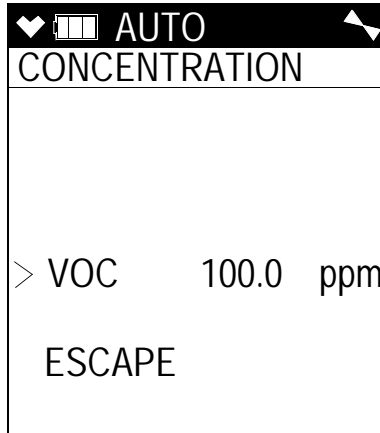

The gas concentration displayed in the Calibration Gas Values Screen must match the gas concentration listed on the PID cylinder.

If the concentration matches, go to Step 11.

If the concentration *does not* match, continue with Step 7.

If you do not want to continue with the concentration adjustment, press and release the DISP/LOCK button to return to the Auto Cal Menu.

- The cursor will already be next to the PID channel.
- Press and release the POWER/ENTER button. The auto cal value will begin to flash.
- Use the ▲AIR and SHIFT ▼(PANIC) buttons to adjust the calibration gas setting to the desired value.
- Press and release the POWER/ENTER button to save the change. The calibration gas value stops flashing.
- When you are done adjusting the calibration gas value, move the cursor to **ESCAPE**.

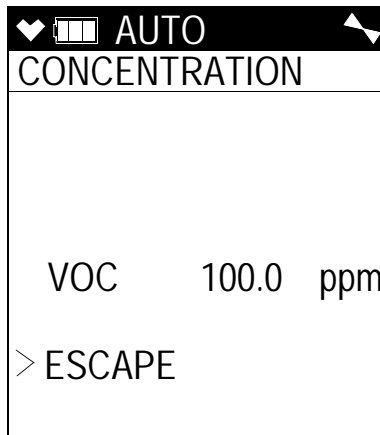

- Press and release the POWER/ENTER button. The instrument returns to the Auto Cal Menu.

- 13 . Use the ▲AIR and SHIFT ▼(PANIC) buttons to move the cursor next to **GAS SELECT**.

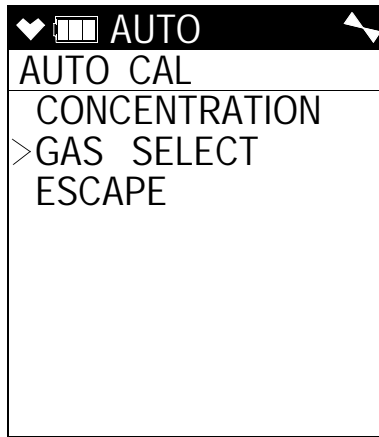

- 14 . Press and release the POWER/ENTER button. The PID sensor screen will be displayed. In addition to the PID sensor screen, there is an **ESCAPE** screen that will take you back to the Auto Cal menu. Use the ▲AIR and SHIFT ▼(PANIC) buttons to scroll between the screens.

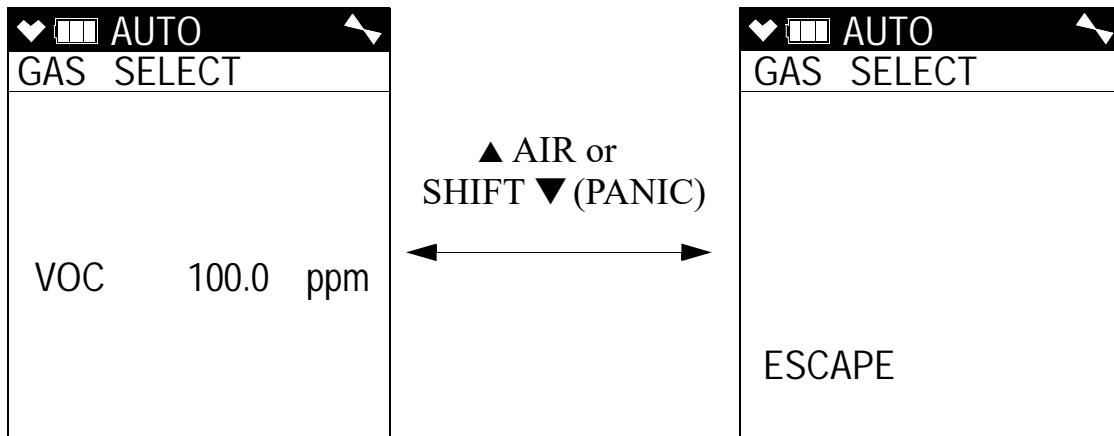

- 15 . With the PID sensor screen displayed, press and release the POWER/ENTER button. The target gas selection screen will display. This screen allows you to select the gas you want to use for calibration. Isobutylene will always be displayed on the top line. The second line will show the gas that is currently selected in the PID Gas Name Screen in Display Mode. In the example below, acetone is the currently selected gas. If isobutylene is the selected gas, then isobutylene will appear twice in this list.

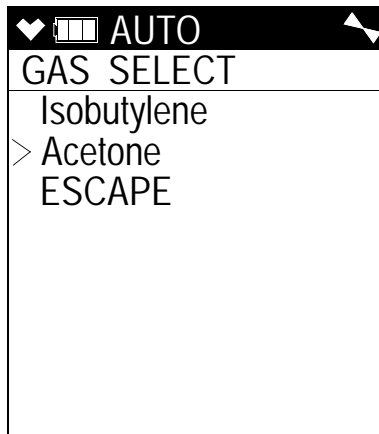

- 16 . Use the ▲AIR and SHIFT ▼(PANIC) buttons to move the cursor next to the gas you want to use for calibration.
- 17 . Press and release the POWER/ENTER button to proceed to the Calibration In Process Screen with **APPLYGAS** and the gas reading flashing.

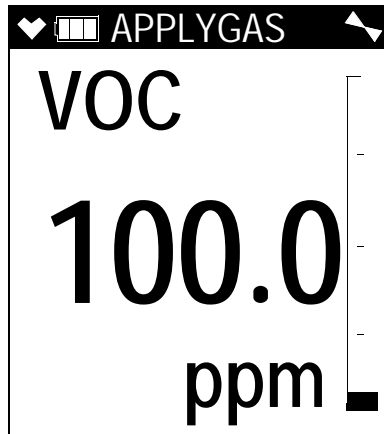

If you do not want to proceed with the calibration, press and release the DISP/LOCK button to return to the Gas Select Screen.

If you do want to continue with the calibration, proceed to the next step.

- 18 . Connect the tubing from the demand flow regulator to the rigid tube on the probe. Allow the GX-6000 to draw gas for one minute.
- 19 . Press and release the POWER/ENTER button to set the span adjustment to the programmed value.
- 20 . If the PID channel passed calibration, the following screen sequence occurs.

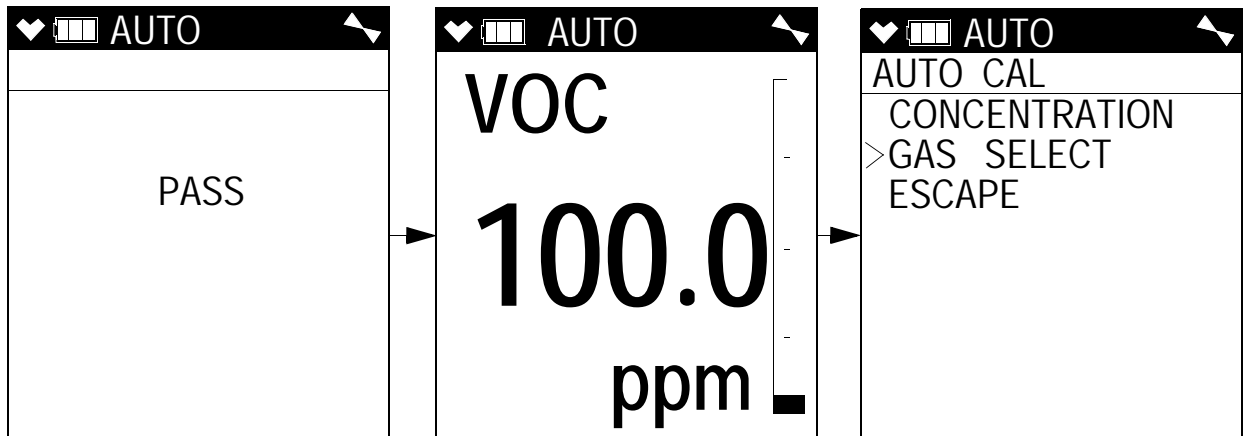

- 21 . If the PID sensor cannot be adjusted to the proper value, a screen displays that indicates a calibration failure.

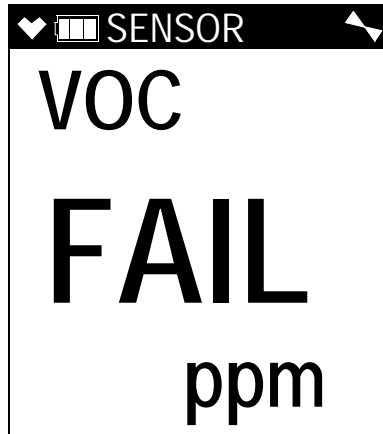

The buzzer and alarm LEDs activate in a double pulsing pattern. Press and release the RESET button to reset the alarm and continue to the Auto Cal Menu. Attempt to calibrate the PID channel again. If the failure continues, investigate the cause. See “Troubleshooting” on page 83.

Returning to Measuring Mode

- 1 . Disconnect the tubing from the probe.
- 2 . Unscrew the demand flow regulator from the calibration cylinder.
- 3 . Use the SHIFT ▼ (PANIC) button to move the cursor next to **ESCAPE**, then press and release the POWER/ENTER button to return to the Calibration Mode Menu.
- 4 . Use the SHIFT ▼ (PANIC) button to place the cursor next to the **NORMAL MODE** menu option, then press and release the POWER/ENTER button to return to Measuring Mode.

Calibrating Using the Single Calibration Method

Setting the Fresh Air Reading

1. While in the Calibration Mode Screen, move the cursor to the **AIR CAL** menu item by using the SHIFT ▼ (PANIC) button.

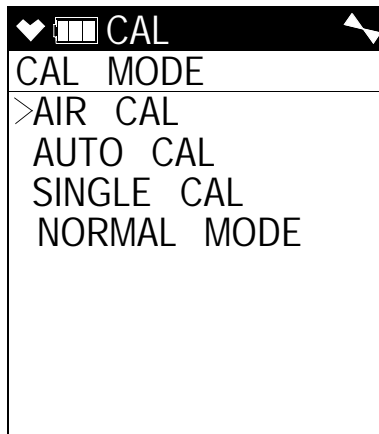

2. Press and release the POWER/ENTER button. The Fresh Air Reading Screen will be displayed.

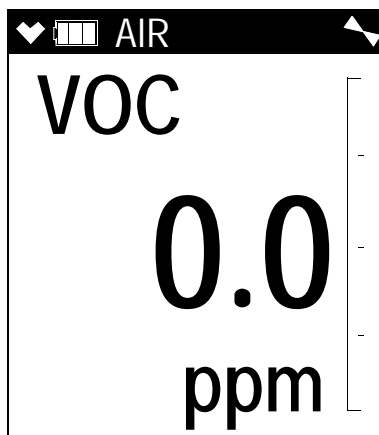

3. If you suspect any low-level VOC background in the area, you will need to use the VOC zero filter.
 - a. Remove the plug from each end of the VOC zero filter.
 - b. Attach the VOC zero filter to the inlet fitting or probe. The filter does not have a preferred flow direction.
 - c. Let the instrument draw through the VOC zero filter for 1 minute before continuing.
4. To continue with the fresh air adjustment, press and hold the ▲AIR button.

If you do not want to continue, press and release the DISP/LOCK button and the unit will return to the Calibration Mode Screen.

5. The GX-6000 will indicate that it is adjusting the zero reading for a few seconds and then it will prompt you to release the ▲AIR button.

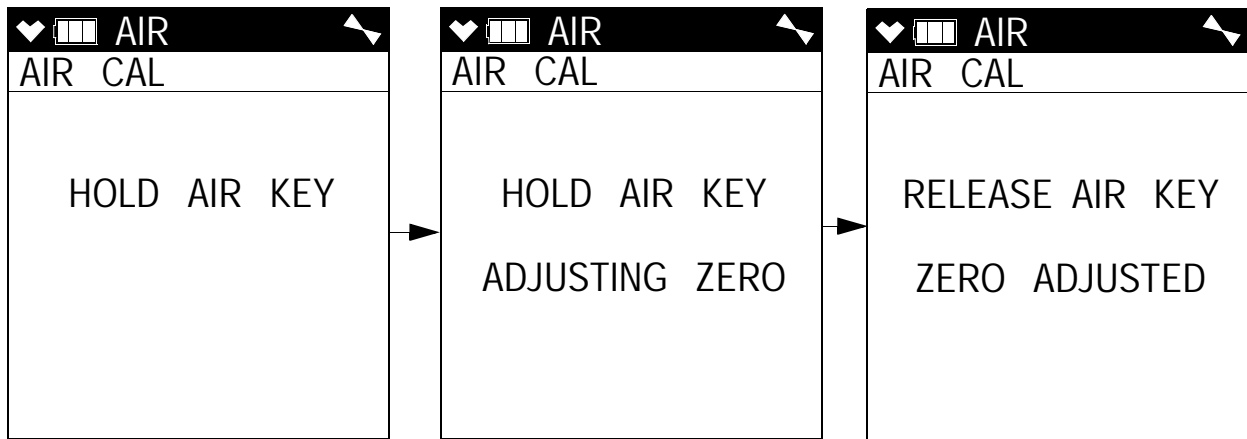

6. Release the ▲AIR button. The fresh air adjustment will finish, the fresh air reading will be displayed momentarily, and then the instrument will return to the Calibration Mode Screen.

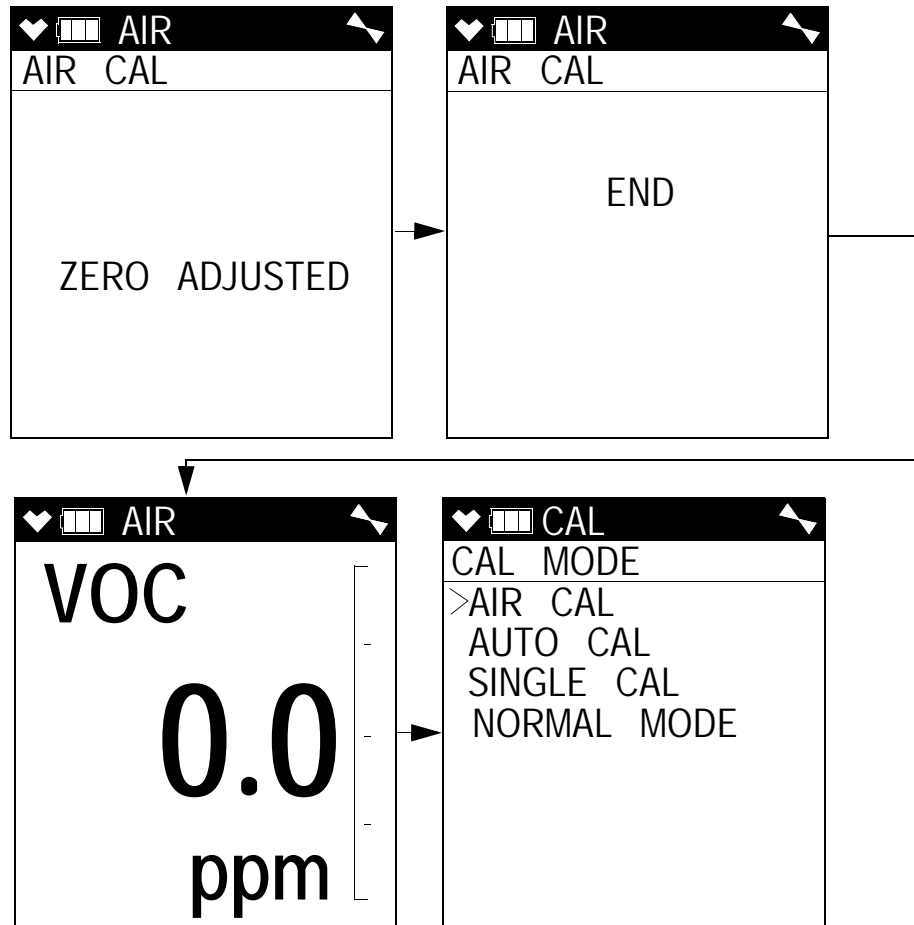

7. If the VOC zero filter was used, remove the filter from the GX-6000's inlet fitting or probe. Reinstall the plugs on each end of the filter.

Performing a Span Adjustment in Single Calibration

1. Install the demand flow regulator onto the calibration cylinder.
2. Connect the sample tubing to the demand flow regulator.
3. Install the sample hose and probe on the GX-6000 inlet fitting. Make sure the probe's two halves are tightened firmly together to avoid leaks that can affect the calibration. See Figure 21, "Replacing the Particle Filter and Hydrophobic Filter Disk" on page 93 for an illustration of the internal parts of the probe.
4. Move the cursor next to the **SINGLE CAL** menu item by using the ▲AIR or SHIFT ▼(PANIC) button.

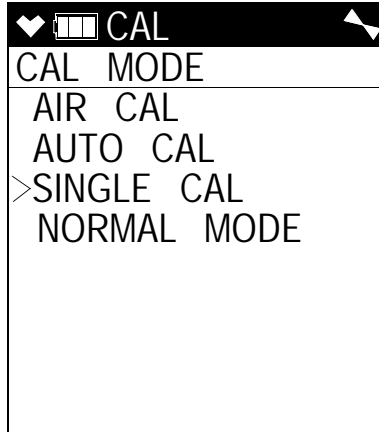

5. Press and release the POWER/ENTER button. The Select Sensor Screen appears.

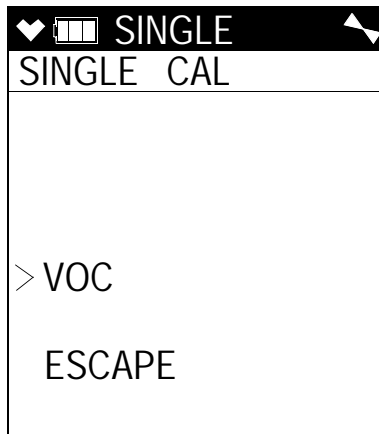

6. The cursor will already be next to the PID channel.
If you do not want to proceed with the span adjustment, press and release the DISP/LOCK button or place the cursor next to **ESCAPE** and press and release POWER/ENTER to return to the Calibration Mode Screen.
To proceed with the calibration, continue with the next step.

7. Press and release the POWER/ENTER button. The target gas selection screen will display. This screen allows you to select the gas you want to use for calibration. Isobutylene will always be displayed on the top line. The second line will show the gas that is currently selected in the PID Gas Name Screen in Display Mode. In the example below, acetone is the currently selected gas. If isobutylene is the selected gas, then isobutylene will appear twice in this list.

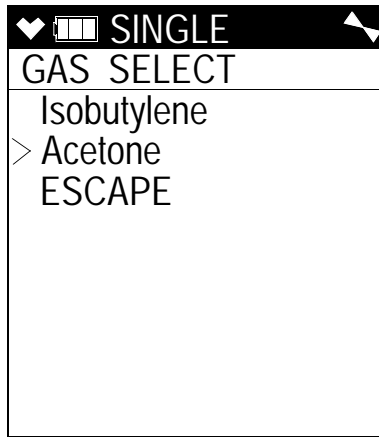

8. Use the ▲AIR and SHIFT ▼(PANIC) buttons to move the cursor next to the gas you want to use for calibration.
9. Press and release the POWER/ENTER button to proceed to the Single Calibration Apply Gas Screen. **APPLYGAS** and the gas reading will be flashing.

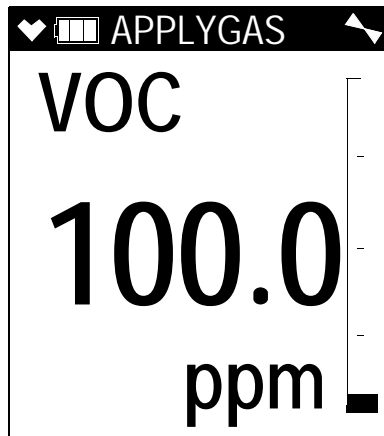

10. Connect the tubing from the demand flow regulator to the rigid tube on the probe. Allow the GX-6000 to draw gas for one minute.
11. If necessary, adjust the reading to match the cylinder concentration with the ▲AIR and SHIFT ▼(PANIC) buttons. If the reading cannot be adjusted to match the cylinder concentration, see “Troubleshooting” on page 83.

- 12 . Press and release the POWER/ENTER button to save the span value. The LCD will indicate that the calibration has ended, then the Select Sensor Screen appears.

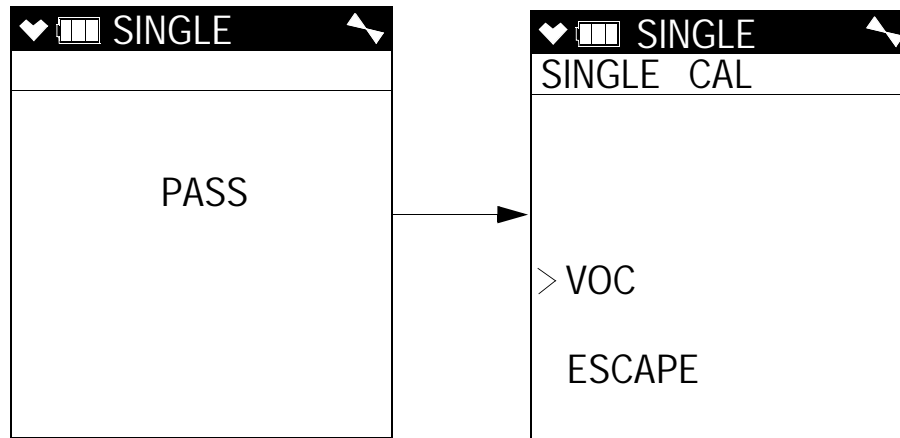

- 13 . Disconnect the tubing from the GX-6000's probe.
- 14 . Unscrew the demand flow regulator from the calibration cylinder.
- 15 . With the Select Sensor Screen displayed, place the cursor next to **ESCAPE** using the ▲AIR or SHIFT ▼ (PANIC) button.

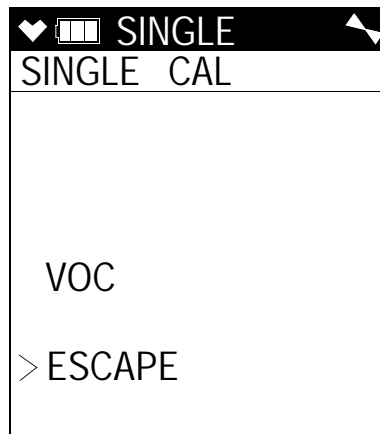

- 16 . Press and release the POWER/ENTER button to return to the Calibration Mode Screen.
- 17 . Use the SHIFT ▼ (PANIC) button to place the cursor next to the **NORMAL MODE** menu item, then press and release the POWER/ENTER button to return to Measuring Mode.

Performing a Bump Test

NOTE: The **BUMP DISP** menu item in Maintenance Mode is factory set to **OFF**. The **BUMP TEST** menu item will not appear unless **BUMP DISP** is set to **ON**. See “Updating the Bump Display Setting (BUMP DISP)” on page 122 for instructions.

NOTE: The GX-6000 uses parameters defined in the **BUMP PARAMETERS** menu item of Maintenance Mode while performing a bump test. To view or update these parameters, see “Updating the Bump Parameters” on page 123.

1. Install the demand flow regulator onto the calibration cylinder.
 2. Connect the sample tubing to the demand flow regulator.
 3. Install the sample hose and probe on the GX-6000 inlet fitting. Make sure the probe’s two halves are tightened firmly together to avoid leaks that can affect the calibration. See Figure 21, “Replacing the Particle Filter and Hydrophobic Filter Disk” on page 93 for an illustration of the internal parts of the probe.
 4. While in Measuring Mode, press and hold the SHIFT ▼ (PANIC) button, then press the DISP/LOCK button and release both buttons.
 5. If the unit prompts you for the password, enter it by using the ▲AIR and SHIFT ▼ (PANIC) buttons to select each password number and then pressing and releasing POWER/ENTER to enter the number and move on to the next one.
-

NOTE: You will only be prompted to enter a password if the **PASSWORD** menu item in User Mode is set to **ON**. See “Turning the Password Function On or Off” on page 81 for instructions to update the **PASSWORD** setting and to choose a password.

6. The Calibration Mode Screen displays with the cursor next to **AIR CAL**.

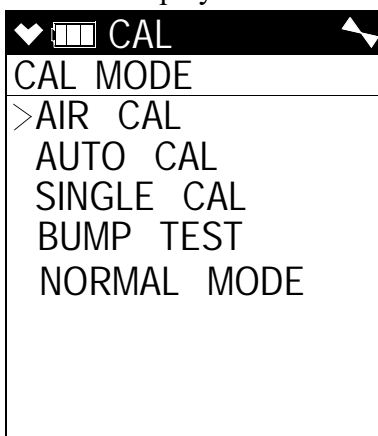

7. Move the cursor next to the **BUMP TEST** menu item by using the SHIFT ▼ (PANIC) button.

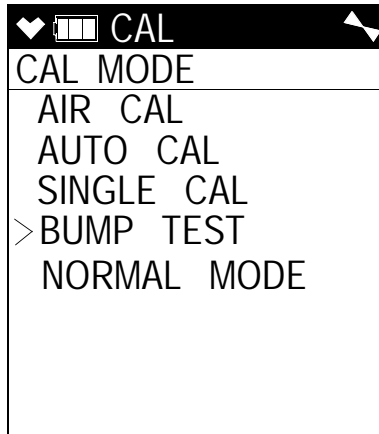

8. Press and release the POWER/ENTER button. The PID sensor screen will be displayed. In addition to the PID sensor screen there is an **ESCAPE** screen that will take you back to the Calibration Mode menu. Use the ▲AIR and SHIFT ▼ (PANIC) buttons to display the PID sensor screen.

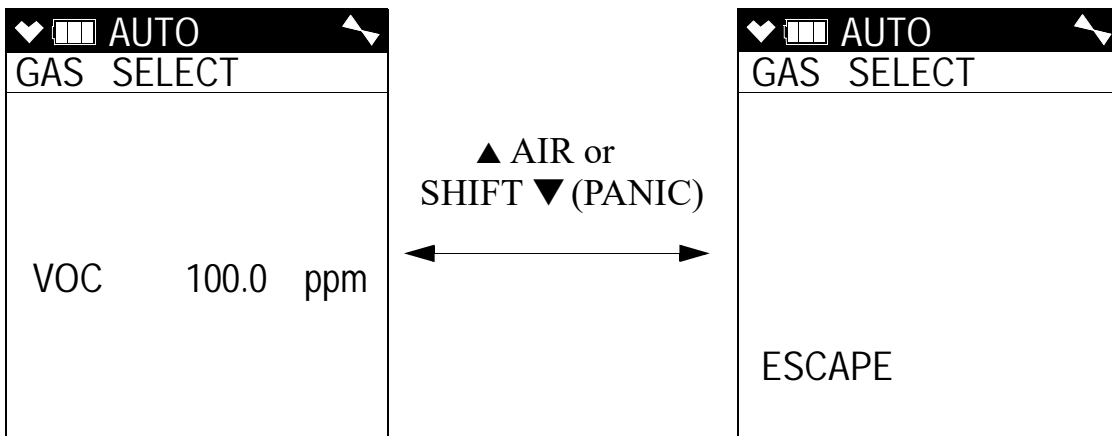

9. Before proceeding, confirm that the bump test gas value is the same as the concentration in the calibration cylinder. If it is not, adjust the bump test gas value by entering the **AUTO CAL** menu item in Calibration Mode, changing the value there, and reentering the **BUMP TEST** menu item.

- 10 . With the PID sensor screen displayed, connect the tubing from the demand flow regulator to the rigid tube on the probe then quickly press and release the POWER/ENTER button to proceed to the Bump In Progress Screen. The instrument will count down.

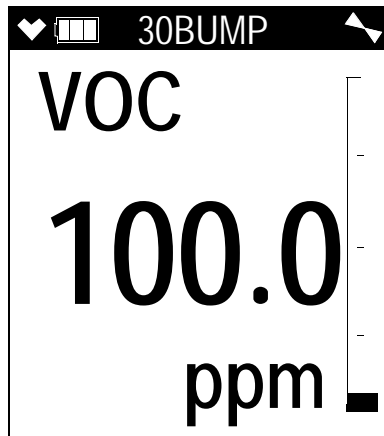

If you do not want to proceed with the bump test, press and release the DISP/LOCK button to return to the Gas Select Screen.

If you do want to continue with the bump test, proceed to the next step.

- 11 . When **AUTO CAL** in the **BUMP PARAMETERS** menu item in Maintenance Mode is set to **OFF**:
 - a. The instrument will indicate whether or not the PID channel passed or failed the bump test with an OK (pass) or an NG (fail) to the right of the gas. You can scroll between the bump test result and the bump test gas reading with the ▲AIR and SHIFT ▼(PANIC) button.

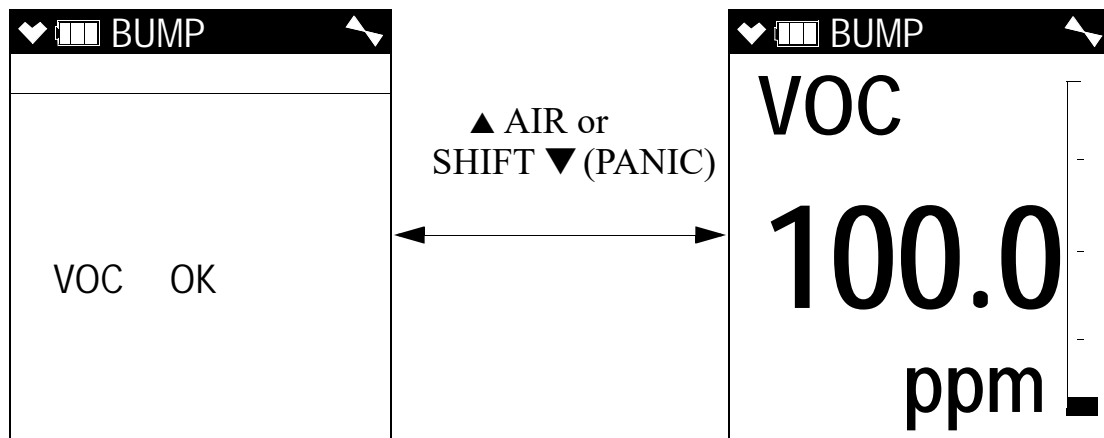

- b. To return to the Gas Select Screen, press and release the POWER/ENTER button. If the PID channel failed the bump test, the buzzer will sound a double pulsing tone until you press and release the POWER/ENTER button.
If the PID sensor failed the bump test, see “Troubleshooting” on page 83 to investigate the cause of the failure and replace the failed sensor, if necessary.
 - c. Disconnect the tubing from the probe.

12 . When **AUTO CAL** in the **BUMP PARAMETERS** menu item in Maintenance Mode is set to **ON**:

If the PID channel passes the bump test:

- a. The results screen appears. You can scroll between the bump test result and the bump test gas reading with the ▲AIR and SHIFT ▼(PANIC) buttons.

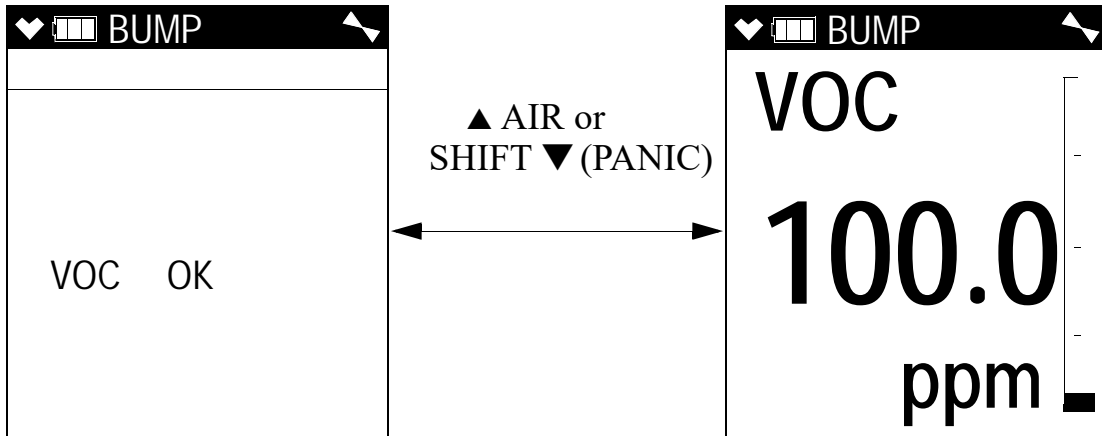

- b. To return to the Gas Select Screen, press and release the POWER/ENTER button.
- c. Disconnect the tubing from the probe.

If the PID channel fails the bump test:

- a. The instrument will beep and a calibration is immediately and automatically started. Continue to apply the calibration gas. CAL will appear at the top of the screen along with a countdown.

The calibration time counted down during a calibration initiated because of a failed bump test is the difference between the gas time and the calibration time defined in the **BUMP SETTING** menu item in Maintenance Mode.

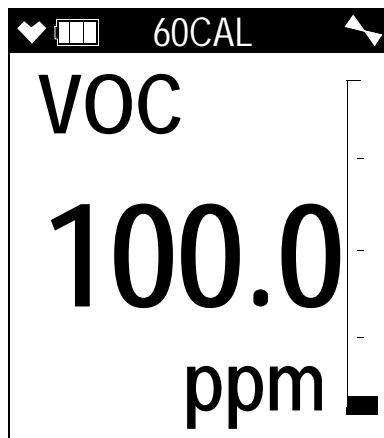

- b. At the end of the calibration, the instrument displays the results from both the bump test and the calibration. Use the ▲AIR and SHIFT ▼(PANIC) button to scroll between the calibration/bump test results, the bump test gas reading, and the calibration gas reading.

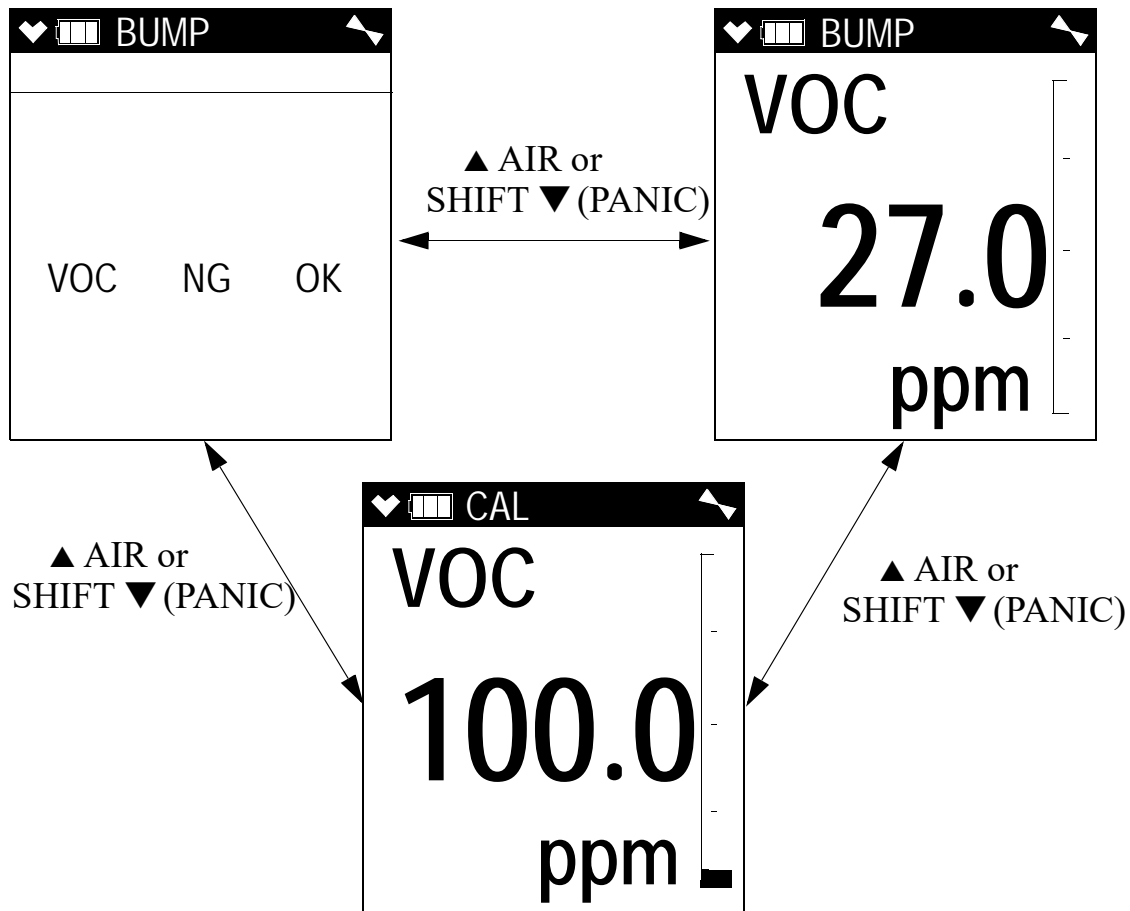

- c. To return to the Gas Select Screen, press and release the POWER/ENTER button at any time. If the PID channel failed the calibration, the buzzer will sound a double pulsing tone until you press and release the POWER/ENTER button.
- d. Disconnect the tubing from the probe.
- 13 . Unscrew the demand flow regulator from the calibration cylinder.
- 14 . Use the SHIFT ▼(PANIC) button to display the **ESCAPE** screen, then press and release the POWER/ENTER button to return to the Calibration Mode Menu.
- 15 . Use the SHIFT ▼(PANIC) button to place the cursor next to the **NORMAL MODE** menu option, then press and release the POWER/ENTER button to return to Measuring Mode.

Chapter 5: User Mode

Overview

This section describes the GX-6000 in User Mode. See Table 10 below for a list of the items found in User Mode, the page that the menu item's instructions can be found on, and a short description of the menu item.

Table 10: User Mode Menu Items

Menu Item (page number)	Description
DATE (pg.79)	Set the instrument's date and time
DATE FORMAT (pg.80)	Set the date format
CONFIGURE CH (pg.80)	N/A
LANGUAGE (pg.80)	Change the instrument's language
ROM/SUM (pg.81)	View the instrument's ROM number and checksum
PASSWORD (pg.81)	Turn the User Mode password function on or off and update the password
START MEASURE (pg.82)	Return to Measuring Mode

Tips for Using User Mode

- When in the main menu, the cursor (>) indicates which menu item will be selected if the POWER/ENTER button is pressed and released.
- Use the SHIFT ▼ (PANIC) button to move the cursor down through the main menu and submenu items, and to lower values or change the setting in a specific option.
- Use the ▲AIR button to move the cursor up through the main menu and submenu items, and to raise values or change the setting in a specific option.
- Use the POWER/ENTER button to enter a selected menu item with the cursor next to it and to enter and save settings during programming.
- An adjustable parameter that is flashing can be adjusted with the ▲AIR and SHIFT ▼ (PANIC) buttons.
- Press the DISP/LOCK button while in a screen where you are entering or updating parameters to exit the screen without saving any changes.

Entering User Mode

WARNING: *The GX-6000 is not in operation as a gas detector while in User Mode.*

1. Take the GX-6000 to a non-hazardous location and turn it off if it is on.
2. Press and hold the ▲AIR and SHIFT ▼ (PANIC) buttons, then press and hold the POWER/ENTER button. When you hear a beep, release the buttons.
3. The screen that appears will depend on the setting of User Mode's **PASSWORD** item.

If **PASSWORD** is set to **OFF** (factory setting), continue with Step 4.

If **PASSWORD** is set to **ON**, continue with Step 6.

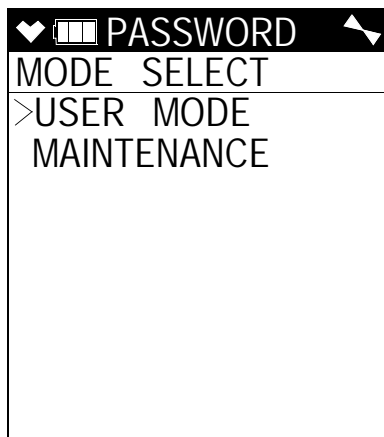

PASSWORD set to **OFF**

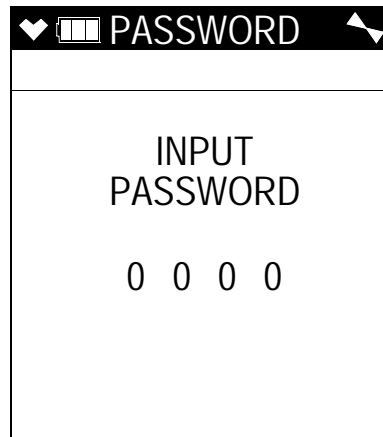

PASSWORD set to **ON**

4. If **PASSWORD** has been set to **OFF**, the Mode Select screen will appear, prompting you to choose the mode you'd like to enter.
5. Use the ▲AIR and SHIFT ▼ (PANIC) buttons to put the cursor in front of **USER MODE** and press and release the POWER/ENTER button. Continue to Step 8.
6. If **PASSWORD** has been set to **ON** in User Mode, a password screen will appear. The first digit will be flashing.
7. Enter the password by using the ▲AIR and SHIFT ▼ (PANIC) buttons to select each password number and then pressing and releasing the POWER/ENTER button to enter it and move on to the next number until all of the numbers are entered. Continue to Step 8.

8. The main menu displays. It has 7 menu items.

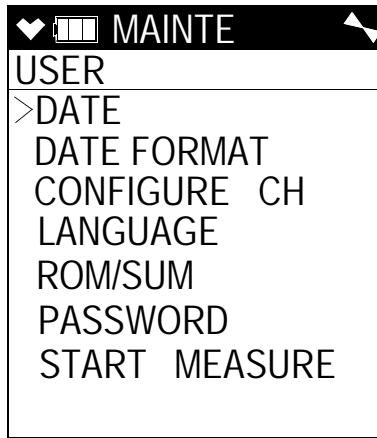

9. Use the ▲AIR or SHIFT ▼ (PANIC) button to move the cursor up and down the menu items.

Setting the Date and Time

NOTE: The example screen shown below assumes a **DATE FORMAT** setting of **MM/DD/YYYY** (factory setting). If your instrument's **DATE FORMAT** is set to something else, your screen will appear different.

1. From the main menu, place the cursor next to **DATE**.
2. Press and release POWER/ENTER. The date and time will be displayed with the year flashing.

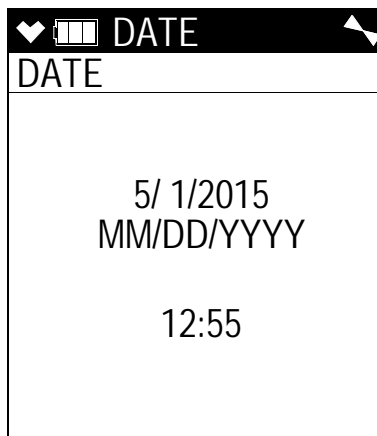

3. Use ▲AIR or SHIFT ▼ (PANIC) to display the desired year.
4. Press and release POWER/ENTER to save the setting. The month setting flashes.
5. Repeat Step 3 and Step 4 to enter the month, day, hours, and minutes settings. The main menu displays after you enter the seconds setting.

Setting the Date Format

The date can be displayed in three ways, **MM/DD/YYYY** (factory setting), **DD/MM/YYYY**, or **YYYY/MM/DD**.

1. From the main menu, place the cursor next to **DATE FORMAT**.
2. Press and release **POWER/ENTER**. The Date Format screen appears with the current setting flashing.
3. Use **▲AIR** or **SHIFT ▼(PANIC)** to display the desired setting.
4. Press and release **POWER/ENTER** to save the setting and return to the main menu.

Configuring the Channels

This menu item does not apply to this version of the GX-6000.

Updating the Language Setting

The **LANGUAGE** menu item allows you to select the language for the GX-6000's user interface. The available choices are English (factory setting), Japanese, Italian, Spanish, German, French, Portuguese, Russian, and Korean.



1. From the main menu, place the cursor next to **LANGUAGE**.
2. Press and release **POWER/ENTER**. The Select Language Screen appears with the cursor in front of the current language.
3. Use **▲AIR** or **SHIFT ▼(PANIC)** to move the cursor in front of the desired language.

If you do not wish to select a new language, press and release **DISP/LOCK**. The unit will return to the main menu.

4. Press and release **POWER/ENTER** to save the new language setting and return to the main menu. The GX-6000's user interface will now be in the newly selected language.

Viewing the ROM/SUM of the Instrument

The **ROM/SUM** screen shows the firmware version that is loaded in the instrument and the firmware checksum.

1. Use the ▲AIR or SHIFT ▼(PANIC) button to place the cursor next to **ROM/SUM**.
2. Press and release the POWER/ENTER button. The ROM and checksum values for your unit will be displayed.

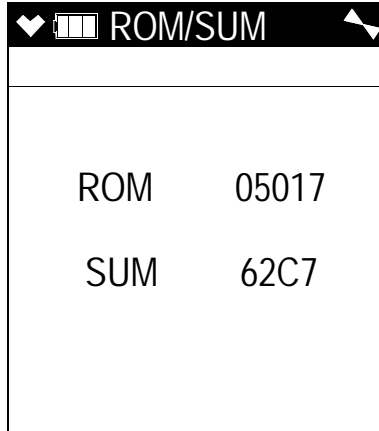

3. The first line displays the ROM number. The ROM number indicates the firmware version number. In the above example, the ROM number is 05017. The bottom line displays the firmware file's checksum, 62C7 in the above example.
4. Press and release the POWER/ENTER button again to return to the main menu.

Turning the Password Function On or Off

With **PASSWORD** set to **ON**, the GX-6000 prompts you for a password when you enter User Mode and Calibration Mode.

With **PASSWORD** set to **OFF** (factory setting), no password is required to enter User Mode or Calibration Mode.

1. From the main menu, place the cursor in front of **PASSWORD**.
2. Press and release POWER/ENTER. The Password Protection Screen appears.

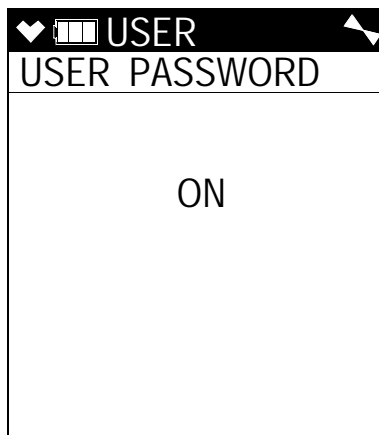

3. Use ▲AIR or SHIFT ▼(PANIC) to display the desired setting.

4. If you selected **OFF**, press and release POWER/ENTER to save the setting and return to the main menu.

If you selected **ON**, continue with Step 5.

5. Press and release POWER/ENTER. The Set Password Screen appears. 0000 is at the bottom of the screen with the first 0 flashing.

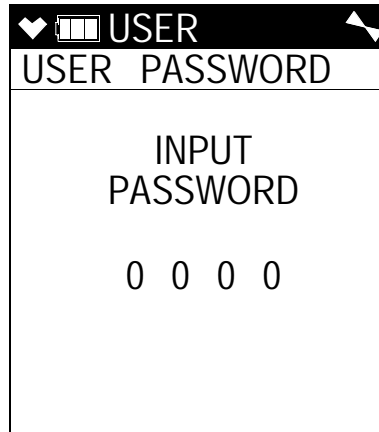

6. Use **▲AIR** or **SHIFT ▼(PANIC)** to display a number from 0 to 9.
7. Press and release POWER/ENTER to enter the selection and advance to the next number.
8. Repeat Step 6 and Step 7 to select the remaining numbers. When you press and release POWER/ENTER to enter the last number, the password is saved and you return to the main menu.

Exiting User Mode

1. From the main menu, place the cursor in front of **START MEASURE** at the bottom of the menu.
2. Press and release POWER/ENTER.
3. The unit will begin its start-up sequence.

Chapter 6: Maintenance

Overview

This chapter describes troubleshooting procedures for the GX-6000. It also includes procedures for replacing and recharging the batteries and replacing various consumable parts.

WARNING: *RKI Instruments, Inc. recommends that service, calibration, and repair of RKI Instruments be performed by personnel properly trained for this work. Replacing the sensor and other parts with original equipment does not affect the intrinsic safety of the instrument.*

Troubleshooting

The troubleshooting table describes error messages, symptoms, probable causes, and recommended action for problems you may encounter with the GX-6000.

Table 11: Troubleshooting the GX-6000

Symptoms	Probable Causes	Recommended Action
<ul style="list-style-type: none">The LCD is blank.	<ul style="list-style-type: none">The unit may have been turned off.The alkaline batteries may need to be replaced or Li-ion battery pack may need to be recharged.	<ol style="list-style-type: none">To turn on the unit, press and briefly hold the POWER/ENTER button.If the unit does not turn on, replace the alkaline batteries or recharge the Li-ion battery pack.If the difficulties continue, contact RKI Instruments, Inc. for further instruction.
<ul style="list-style-type: none">The LCD shows an abnormally high or low reading but other gas detection instruments do not.	<ul style="list-style-type: none">The GX-6000 may need to be recalibrated.The sensor may need replacement.	<ol style="list-style-type: none">Recalibrate the unit.If the difficulties continue, replace the sensor and calibrate again.If the difficulties continue, contact RKI Instruments, Inc. for further instruction.
<ul style="list-style-type: none">The unit indicates flow failure and does not recover when RESET is pressed and released.	<ul style="list-style-type: none">The probe tube is clogged.The hydrophobic filter disk in the probe is dirty.The sample hose has a kink or obstruction.The pump is malfunctioning.	<ol style="list-style-type: none">Inspect the probe tube for any obstructions.Inspect the hydrophobic filter disk in the probe and replace if necessary.Inspect the sample hose for kinks or obstructions and replace if necessary.Attempt to set the low flow setpoint as described in "Adjusting the Low Flow Setpoint (FLOW ADJUST)" on page 135.If difficulties continue, contact RKI Instruments, Inc. for further instruction.

Table 11: Troubleshooting the GX-6000

Symptoms	Probable Causes	Recommended Action
<ul style="list-style-type: none"> • Auto calibration or single calibration fails. 	<ul style="list-style-type: none"> • The auto calibration value may not match the cylinder gas concentration (auto calibration only). • The sample gas is not reaching the sensor because of a bad connection. • The calibration cylinder may be out of gas or is outdated. • The lamp may need to be cleaned. • The electrode stack may need to be replaced. • The sensor may need replacement. 	<ol style="list-style-type: none"> 1. Check all calibration tubing for leaks or for any bad connections. 2. Make sure the GX-6000 has been properly set up for calibration. 3. Verify that the calibration cylinder contains an adequate supply of fresh test sample. 4. Clean the PID sensor's lamp. 5. Replace the PID sensor's electrode stack. 6. If the fail condition continues, replace the sensor. 7. If the difficulties continue, contact RKI Instruments, Inc. for further instruction.
<ul style="list-style-type: none"> • Heart symbol at the top of the screen becomes steadily on or disappears 	<ul style="list-style-type: none"> • A microprocessor error has occurred. 	<ul style="list-style-type: none"> • Contact RKI Instruments, Inc. for further instruction.
<ul style="list-style-type: none"> • Instrument does not go into low flow alarm when inlet is plugged. 	<ul style="list-style-type: none"> • Sensor gasket is not seated properly. 	<ul style="list-style-type: none"> • Turn the instrument off and remove the flow chamber. Ensure that the sensor gasket's flow fitting connections are facing up and that the gasket is secured under the gasket aligning tabs.

Replacing or Recharging the Batteries

WARNING: *To prevent ignition of a hazardous atmosphere, batteries must only be changed or charged in an area known to be nonhazardous.*

AVERTISSEMENT: *Pour éviter l'inflammation d'une atmosphère dangereuse, les batteries doivent uniquement être modifiés ou facturés dans une zone connue comme non dangereuse.*

Replace or recharge the batteries when the battery icon indicates that the unit is in low battery warning. When in low battery warning, the lowest battery level indication bar disappears and the battery icon will be flashing.

Replacing Alkaline Batteries

NOTE: Use Procell PC 1500 alkaline batteries or RKI Instruments, Inc. lithium-ion battery pack 49-1619 to maintain the CSA classification of the GX-6000. Use of other batteries will void the CSA classification and may void the warranty. Do not mix old/new or different types of batteries.

NOTE: Utiliser Procell 1500 piles alcalines ou RKI Instruments, Inc. pack batterie lithium-ion 49-1619 de maintenir la classification CSA de la GX-6000. L'utilisation d'autres piles annule la classification CSA et peut annuler la garantie. Ne mélangez pas les anciennes/nouvelles ou différents types de piles.

1. Turn off the GX-6000.

WARNING: *Do not remove the batteries while the GX-6000 is on.*

2. Turn the GX-6000 over so that the flow chamber and battery cover are facing up and the LCD is facing down.
3. Push the battery cover latch toward the bottom of the instrument.

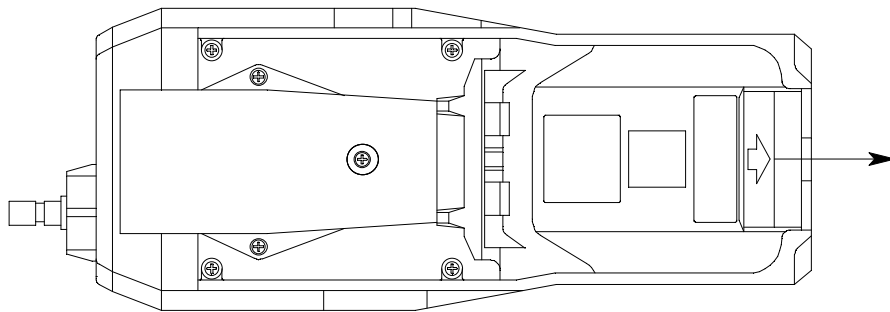

Figure 10: Releasing Battery Cover Latch

4. Grasp the end of the battery cover that's closest to the bottom of the instrument and lift it up.

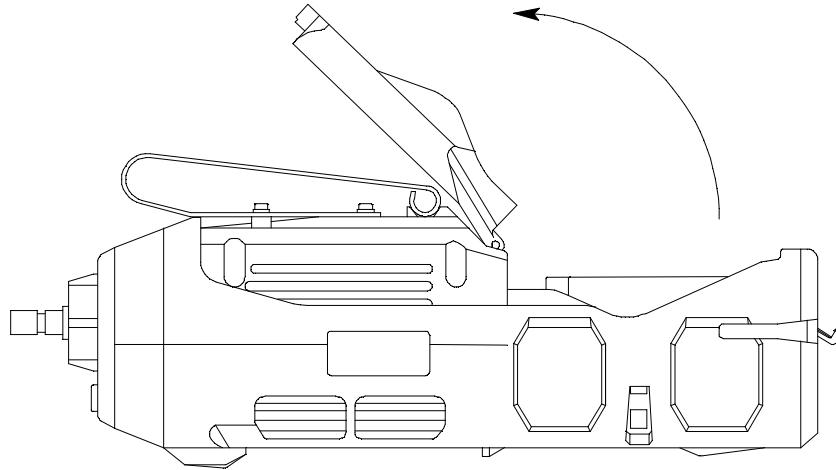

Figure 11: Opening Battery Cover

5. Carefully remove the old alkaline batteries. Verify that the battery compartment and electrical contacts are clean.
6. Carefully install the new AA alkaline batteries according to the battery diagram inside the battery compartment.

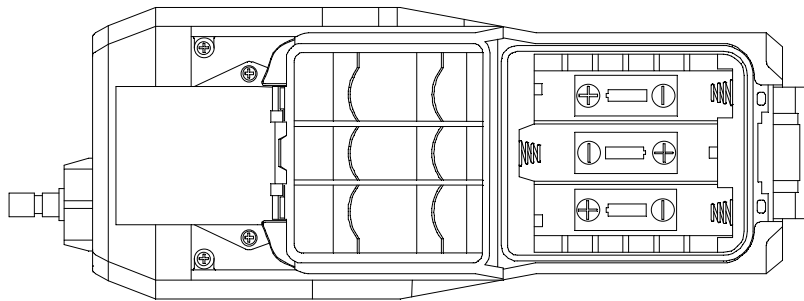

Figure 12: Installing the Alkaline Batteries

7. Close the battery cover and secure the battery cover latch by pushing it up and toward the top of the instrument.

Replacing the Lithium Ion Battery Pack

NOTE: Use Procell PC 1500 alkaline batteries or RKI Instruments, Inc. lithium-ion battery pack 49-1619 to maintain the CSA classification of the GX-6000. Use of other batteries will void the CSA classification and may void the warranty. Do not mix old/new or different types of batteries.

NOTE: Utiliser Procell 1500 piles alcalines ou RKI Instruments, Inc. pack batterie lithium-ion 49-1619 de maintenir la classification CSA de la GX-6000. L'utilisation d'autres piles annule la classification CSA et peut annuler la garantie. Ne mélangez pas les anciennes/nouvelles ou différents types de piles.

1. Turn off the GX-6000.

WARNING: *Do not remove the battery pack while the GX-6000 is on.*

2. Remove the rubber boot, if installed.
3. Turn the GX-6000 over so that the flow chamber and battery cover are facing up and the LCD is facing down.
4. The battery pack release latch is located on the bottom of the instrument and is closer to the front of the case than the back.
5. Slide the battery pack release latch to the right with one hand and lift up on the battery pack with the other.

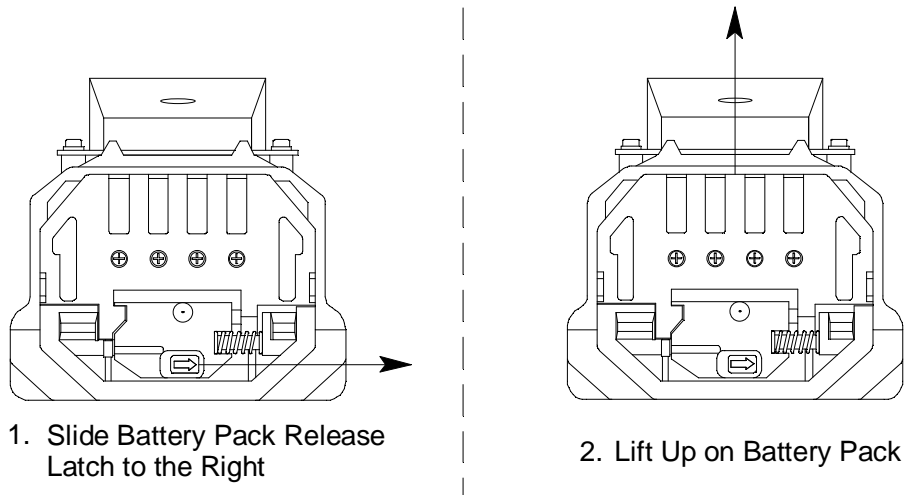

Figure 13: Releasing the Battery Pack

6. Slide the battery pack away from the instrument.

7. Install a new battery pack. If the battery pack release latch moved back into its closed position, slide the latch to the right with one hand and insert a new battery pack with the other.

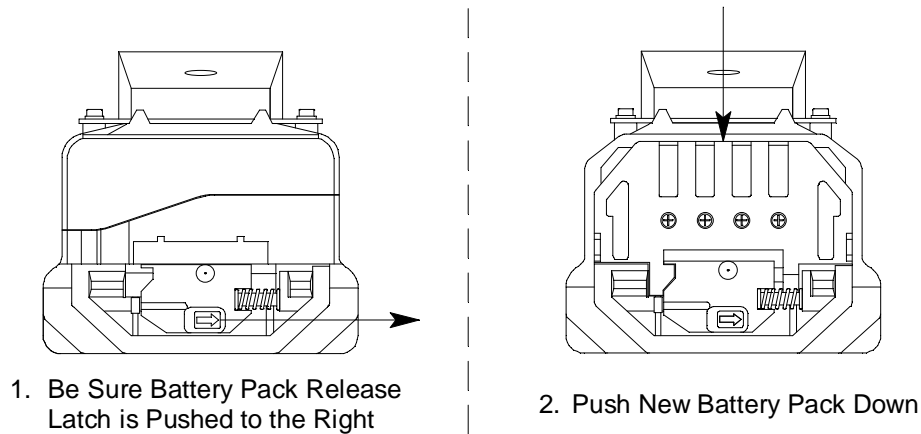

Figure 14: Installing the Battery Pack

8. Release the battery pack release latch. If it does not return to its closed position automatically, push the latch to the left and toward the instrument until it is flush with the bottom of the instrument.
9. Reinstall the rubber boot, if desired.

Recharging the Lithium Ion Battery Pack in the Instrument

CAUTION: *To be used only with lithium ion battery pack p/n 49-1619. Charge only with RKI charger model BC-6000, p/n 49-2182, or RKI charger model BC-6000DC, p/n 49-2183. Use of other rechargeable batteries or chargers or charging of other rechargeable batteries in the GX-6000 will void the warranty.*

PRUDENCE: *Pour être utilisé uniquement avec une batterie au lithium-ion p/n 49-1619. Charge uniquement en fonction du modèle de chargeur RKI BC-6000, p/n 49-2182, ou modèle de chargeur BC-6000DC RKI, p/n 49-2183. L'utilisation d'autres piles ou chargeurs rechargeables ou charger d'autres batteries rechargeables dans le GX-6000 annule la garantie.*

The charger can be mounted to the wall using DIN rail, if desired. See “DIN Rail Mounting Assembly” on page 17 for instructions.

1. Make sure the GX-6000 is off.
2. Confirm that the power adapter’s DC output cord is plugged into the charger.

3. If using an AC powered charging station, plug the AC adapter into an electrical outlet.

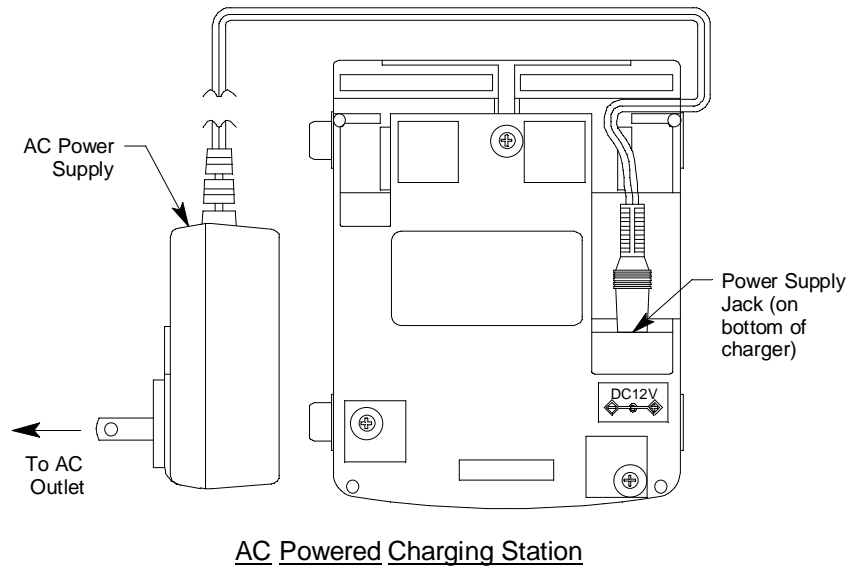

Figure 15: Connecting the Charging Station's AC Adapter

If using a DC powered charging station, plug the 12 VDC vehicle plug adapter into a vehicle's 12 VDC power socket.

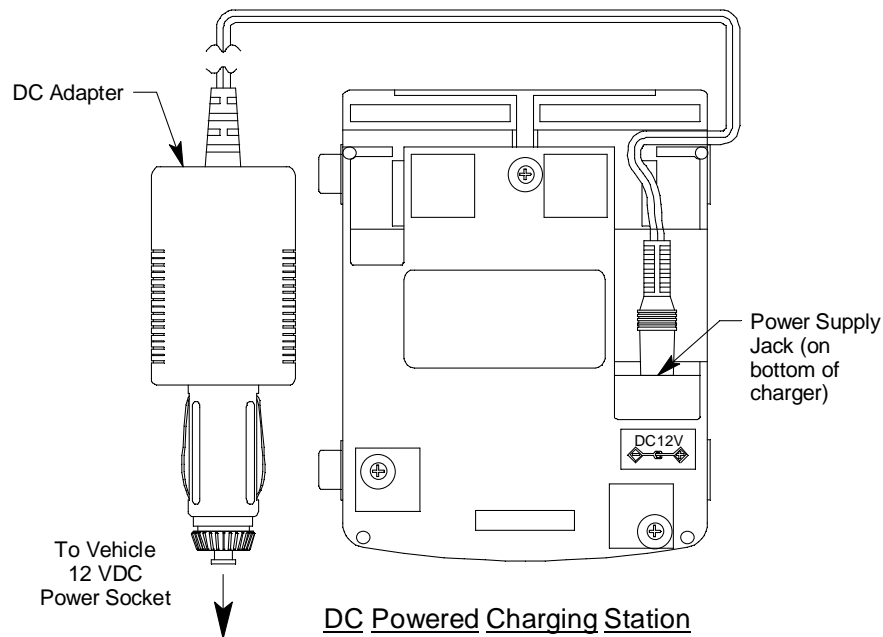

Figure 16: Connecting the Charging Station's DC Adapter

The construction of the charging stations allows them to be chained together but a separate adapter must be used for each charging station. One adapter will not operate more than one charging station.

4. Place the GX-6000 into the battery charging station as shown in Figure 17 below so that the metal contacts on the back of the unit come into contact with the metal contacts on the back of the holder in the charging station. When proper contact has been made, the red LED on the charging station will turn on.

If you are using a DC adapter, the charging station comes with a Velcro strap and washer assembly to secure the GX-6000. Ensure that the washer is installed over the GX-6000's inlet fitting, that both ends of the Velcro strap are attached to the charging station, and that the assembly is securing the instrument.

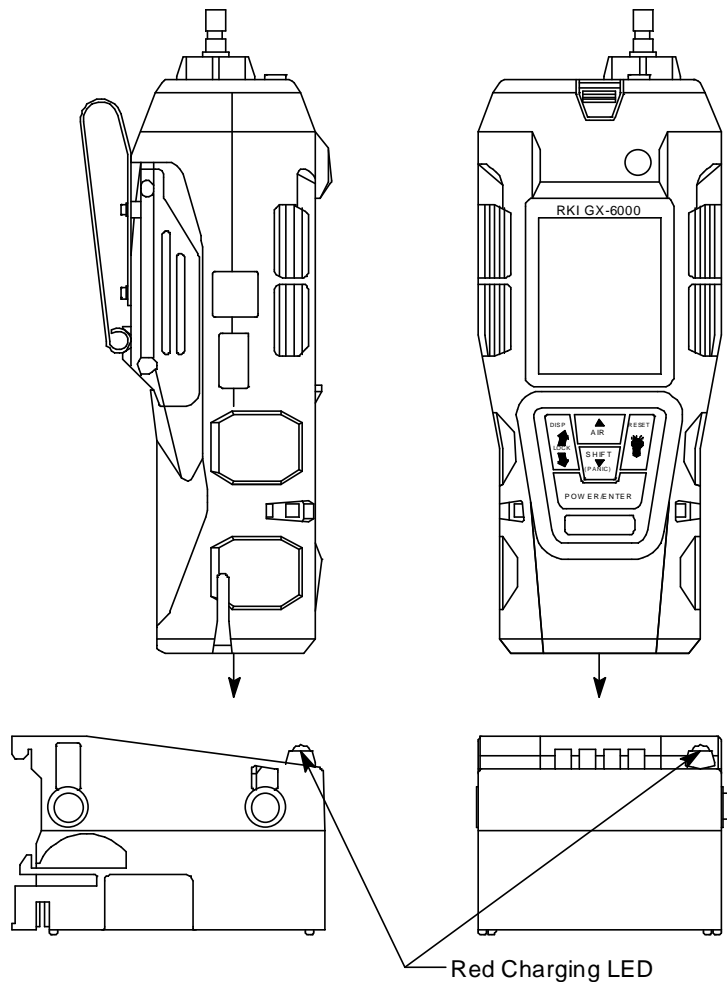

Figure 17: Putting the GX-6000 into the Charging Station

5. When a full charge has been reached, approximately 3 hours, the red LED on the charging station will turn off. Remove the GX-6000 from the charging station and unplug the charging station's power cord from the AC outlet.

Recharging the Lithium Ion Battery Pack Out of the Instrument

The lithium ion battery pack may be charged using the charging station while it is out of the GX-6000. This is useful if spare battery packs are kept in case the pack in the GX-6000 needs to be charged, but the unit must be used immediately. In this case, a spare charged pack can be installed in the GX-6000 and the dead pack charged in the charging station.

The charger can be mounted to the wall using DIN rail, if desired. See “DIN Rail Mounting Assembly” on page 17 for instructions.

1. Make sure the GX-6000 is off.
2. Confirm that the power adapter's DC output cord is plugged into the charger.

3. If using an AC powered charging station, plug the AC adapter into an electrical outlet.

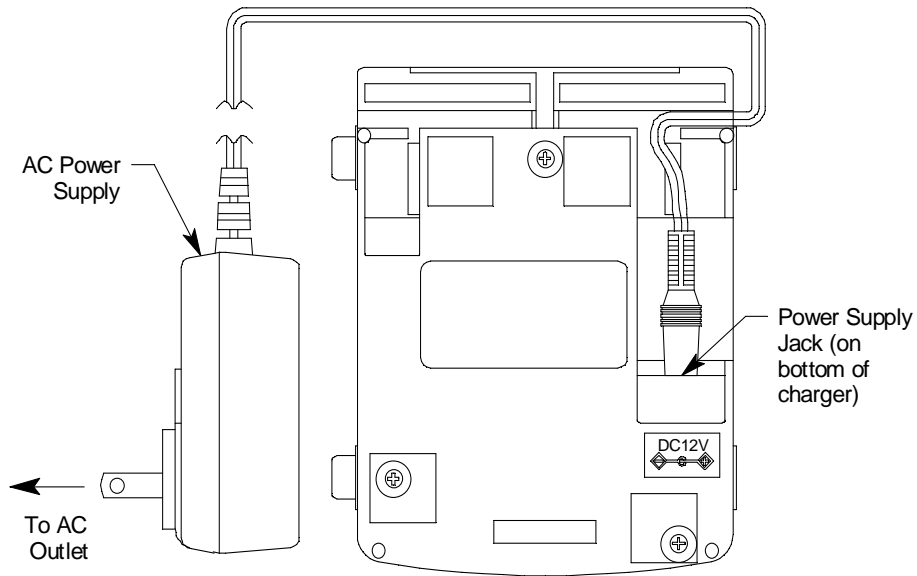

AC Powered Charging Station

Figure 18: Connecting the Charging Station's AC Adapter

If using a DC powered charging station, plug the 12 VDC vehicle plug adapter into a vehicle's 12 VDC power socket.

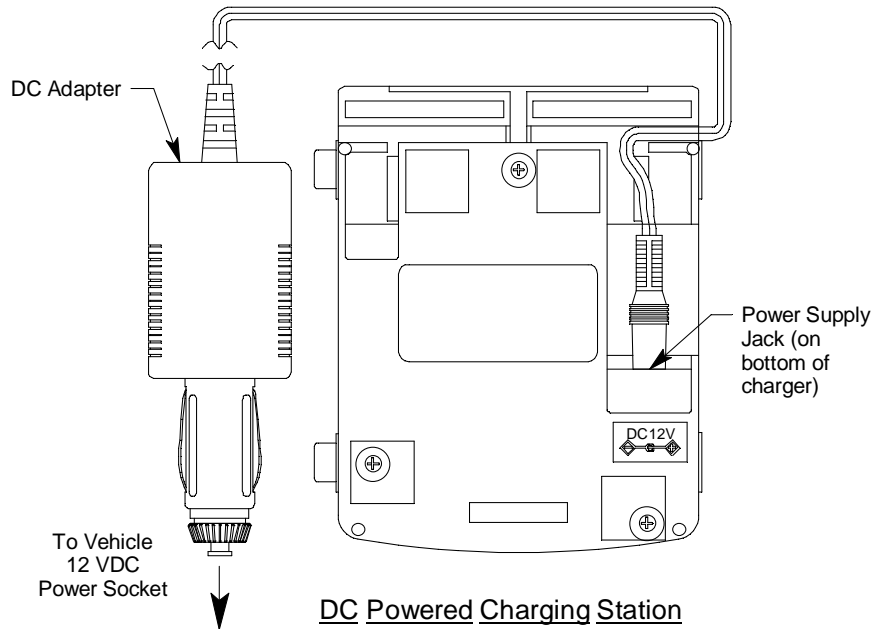

DC Powered Charging Station

Figure 19: Connecting the Charging Station's DC Adapter

The construction of the charging stations allows them to be chained together but a separate adapter must be used for each charging station. One adapter will not operate more than one charging station.

4. If necessary, remove the battery pack from the instrument as described in Step 1 - Step 6 in "Replacing the Lithium Ion Battery Pack" on page 87.

5. Insert the battery pack into the charging station as shown in Figure 20 below so that the metal contacts on the back of the battery pack come into contact with the metal contacts in the charging station. When proper contact has been made, the red LED on the charging station will turn on.

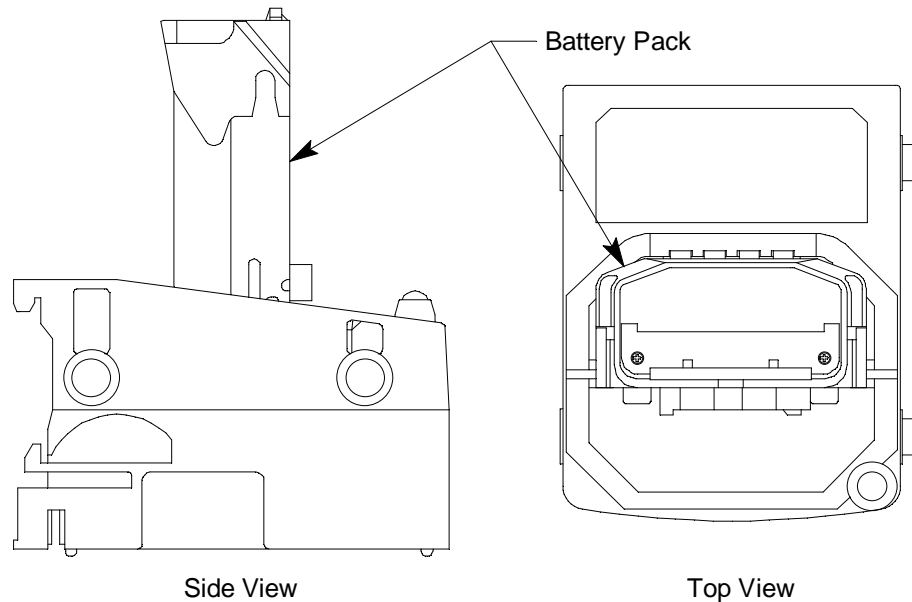

Figure 20: Putting the Battery Pack into the Charging Station

6. When a full charge has been reached, approximately 3 hours, the red LED on the charging station will turn off. Remove the battery pack from the charging station and unplug the charging station's power cord from the AC outlet.
7. If necessary, reinstall the battery pack as described in Step 7 - Step 8 of "Replacing the Lithium Ion Battery Pack" on page 87.

Replacing the Probe's Particle Filter and Hydrophobic Filter Disk

Inspect the probe's internal components if you notice that the GX-6000's pump sounds bogged down or if an unexplained low flow alarm occurs. Replace the particle filter and hydrophobic filter disk if they appear dirty or saturated with liquid. Replace the gasket in the probe if it appears damaged.

1. Hold the sample hose and probe assembly so that the probe tip is pointing up.
2. Grasp each end of the clear probe body firmly and unscrew the two halves from each other. The top half includes the probe tube and the bottom half includes the sample hose.

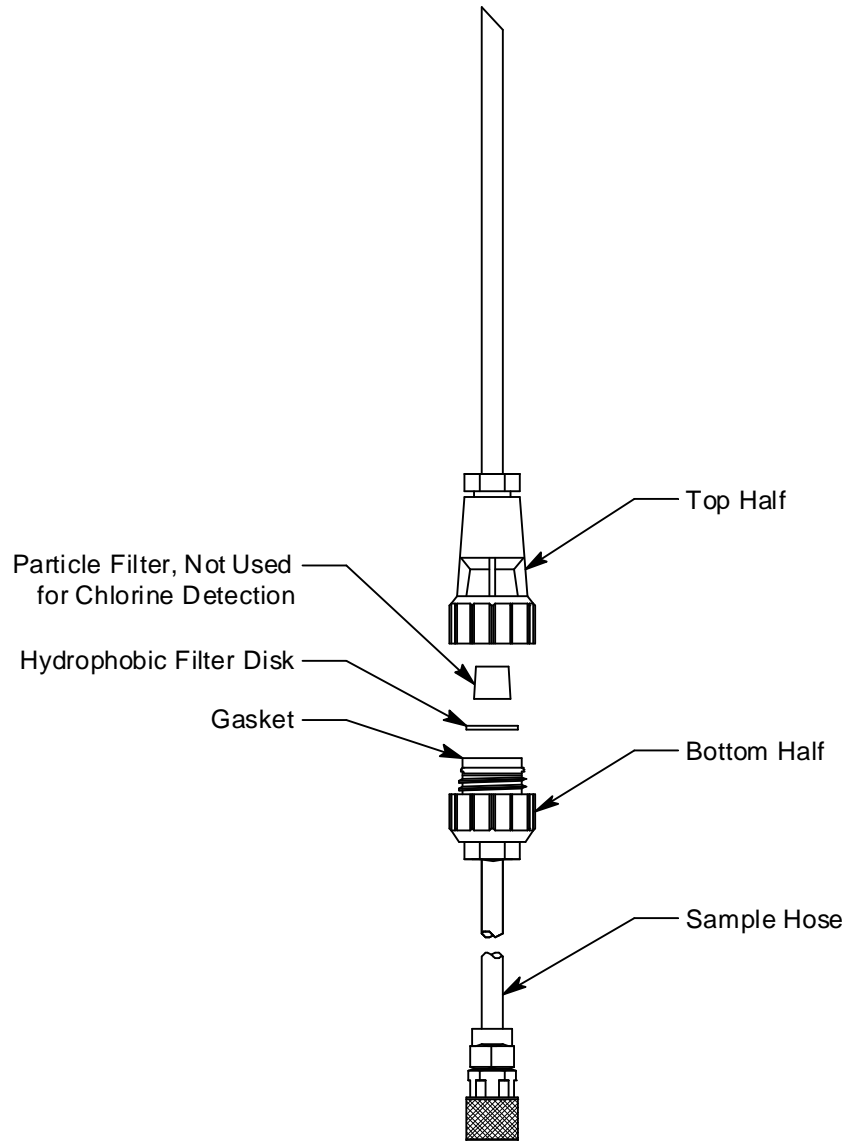

Figure 21: Replacing the Particle Filter and Hydrophobic Filter Disk

3. Set the top half aside. Make sure the bottom half remains oriented with the sample hose facing down.

4. The particle filter should be sitting on top of the hydrophobic filter disk. If it is not, remove it from the top half of the probe.
5. Remove the white hydrophobic filter disk from the top of the bottom half. The disk sits in a black gasket.
6. Place the new filter disk flat on top of the gasket. Make sure that it sits in the gasket and does not extend over the gasket's edge.
7. Set the new particle filter on top of the filter disk. The bigger end should be facing down.
8. Carefully screw the top half onto the bottom half disk while keeping the probe oriented with the probe tip facing up and the sample hose facing down. The particle filter fits into a recess in the top half of the probe. Be sure the particle filter is not compressed in any way.
9. Tighten the halves together very firmly to ensure a seal.
10. To test the seal, do the following.
 - a. Install the probe on the GX-6000.
 - b. Startup the GX-6000.
 - c. Confirm that a low flow alarm occurs when you cover the end of the probe tube with your finger.
 - d. If a low flow alarm does not occur, hand tighten the probe further.
 - e. If a low flow alarm still does not occur when you cover the probe tube with your finger, disassemble the probe, inspect the placement of the hydrophobic filter disk, reassemble the probe, and re-test it.

Replacing the PID Sensor

1. Verify that the GX-6000 is off.
2. Use a small Phillips screwdriver to unscrew the four screws holding the flow chamber to the rest of the GX-6000's case.
3. Grasp the sides of the flow chamber and lift it away from the rest of the case. The screws are captive screws and will not come out of the flow chamber.
4. Gently pull up the edges of the sensor gasket to loosen it from its connections. The sensor will be exposed.
5. Remove the sensor from its socket.
6. Carefully insert the replacement sensor in the PID sensor position.

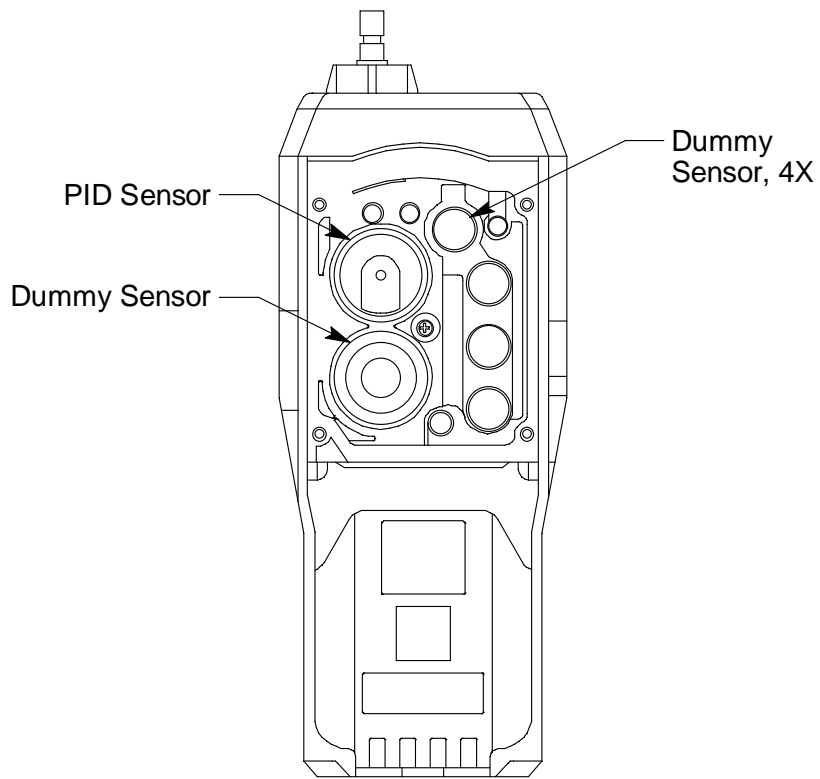

Figure 22: Replacing a Sensor

CAUTION: *When replacing the PID sensor, verify that the sensor is properly aligned with its socket before inserting it into the socket. Forcing the sensor into its socket may damage the sensor or the socket.*

7. Ensure that the dummy sensors are still installed correctly. Make sure that the flat side is up and the hollow side is down.
8. Place the sensor gasket and filters back over the sensors ensuring that the sensor gasket seals with the sensors and the flow fittings. The flow fitting connections need to be facing up and cannot be skewed sideways. The gasket must be pushed down in the center and secured under the gasket aligning tabs.

Failure to install the sensor gasket appropriately may result in inaccurate gas readings.

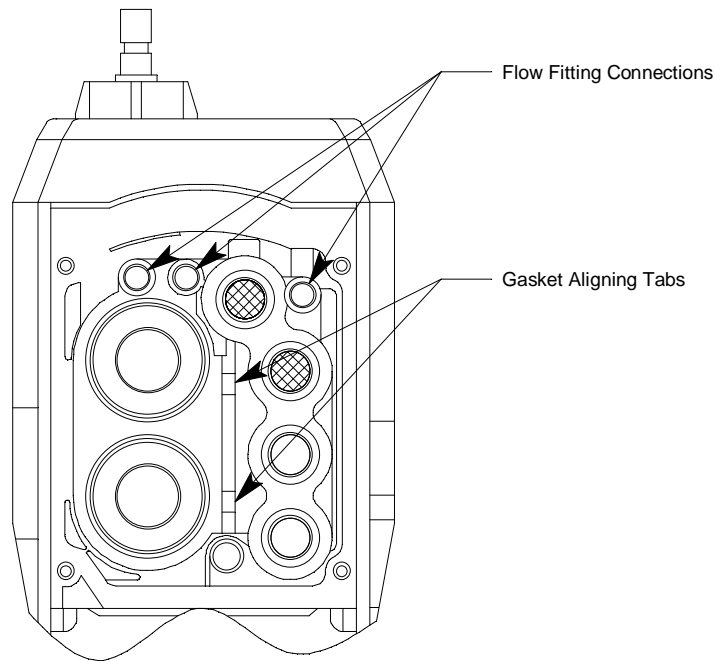

Figure 23: Sensor Gasket Seating

- 9 . Insert the flow chamber back into the instrument.
- 10 . Tighten the flow chamber's four screws that were loosened in Step 2.
- 11 . Start up the GX-6000 by pressing and briefly holding the POWER/ENTER button.
- 12 . To verify that the sensor gasket was inserted properly:
 - a. Plug the inlet with your finger.
 - b. Verify that the GX-6000 goes into low flow alarm. If the GX-6000 does not go into low flow alarm, turn the instrument off and attempt to seat the sensor gasket again.
- 13 . Calibrate the new sensor as described in "Chapter 4: Calibration Mode" on page 58.

Replacing the Hydrophobic Filter and Wire Mesh Disk

1. Verify that the GX-6000 is off.
2. Locate the clear plastic filter holder at the top of the GX-6000.
3. Grasp the filter holder and turn it 1/4 turn counterclockwise.
4. Pull the filter holder away from the case.
5. The wire mesh disk and hydrophobic filter are located in the case and are retained by a rubber gasket.

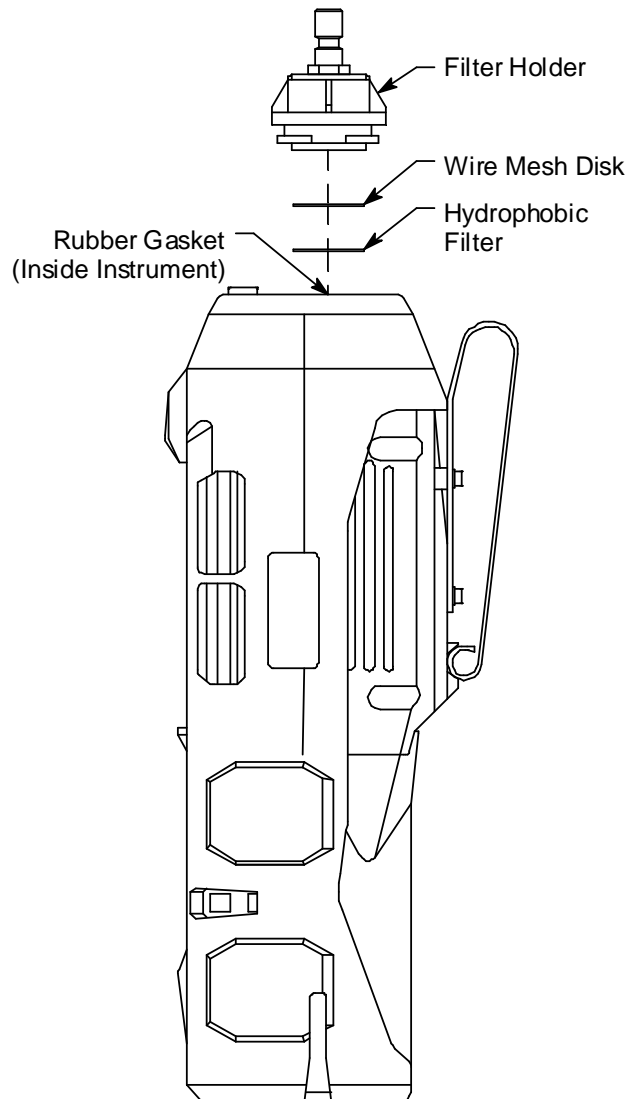

Figure 24: Changing the Filter & Wire Mesh Disk

6. Using a small flat head screwdriver, carefully pry the wire mesh disk and hydrophobic filter from the gasket. Do not remove the gasket.
7. Carefully install the new hydrophobic filter and/or wire mesh disk making sure the wire mesh disk is on top of the hydrophobic filter.

8. Reinstall the filter holder. Align the two wide tabs on the bottom of the filter holder with the two wide slots in the case where the filter holder fits. Push the filter holder into the case and turn it 1/4 turn clockwise until it snaps into place.

PID Sensor Maintenance

The PID sensor includes user serviceable parts. They are the lamp and the electrode stack. The following sections include procedures for cleaning the lamp, replacing the lamp, and replacing the electrode stack.

Cleaning the PID Sensor's Lamp, 10.0 eV and 10.6 eV Lamps

Clean the lamp if you notice a significant drop in sensitivity from one scheduled calibration to another or if you are not able to calibrate the PID channel. See the Table 13 on page 109 for lamp cleaning kit ordering information. The lamp cleaning kit for the 10.0 eV and 10.6 eV PID sensors includes the following items:

- an electrode stack removal tool
- a small vial of aluminum oxide powder
- 40 cotton swabs
- 10 finger cots

CAUTION: *The aluminum oxide cleaning kit is only for use with the 10.0 eV and 10.6 eV PID sensors' lamps. An anhydrous methanol cleaning kit is used to clean the 11.7 eV PID sensor's lamp. DO NOT USE THE ALUMINUM OXIDE CLEANING KIT TO CLEAN THE 11.7 eV PID SENSOR'S LAMP! See "Appendix D: 11.7 eV PID Sensor" on page 166 for 11.7 eV lamp cleaning kit information.*

Perform the following procedure to clean the PID lamp:

1. Verify that the GX-6000 is off.
2. Use a small Phillips screwdriver to unscrew the four screws holding the flow chamber to the rest of the GX-6000's case.
3. Grasp the sides of the flow chamber and lift it away from the rest of the case. The screws are captive screws and will not come out of the flow chamber.
4. Gently pull up the edges of the sensor gasket to loosen it from its connections. The sensor will be exposed.
5. Grasp the PID sensor firmly and pull it out of its socket.
6. Place the PID sensor face down on a flat clean working surface.

NOTE: Do not touch the lamp window with your fingers as this may contaminate the window with finger oil. At this point it is recommended that the finger cots be used on the fingers handling the lamp. Finger cots are included with the lamp cleaning kit.

7. Hold the PID sensor steady on the working surface with one hand and using the other hand, locate the tabs on the electrode stack removal tool and insert them into the slots on the side of the PID sensor near the face.



Figure 25: Using Removal Tool

8. Squeeze the removal tool to push the tabs into the sensor slots until the electrode stack and lamp are released.
9. Carefully lift the PID sensor body away from the electrode stack and lamp. Take care not to touch the lamp window, the flat end of the lamp, with your fingers. If the lamp remains lodged in the sensor body, carefully remove it with tweezers.



Figure 26: Lamp Window Location

10. If the spring in the lamp cavity comes out, place it back into the lamp cavity.
11. Hold the lamp in one hand being careful not to touch the lamp window with your fingers.
12. With the other hand collect a small amount of aluminum oxide powder on a cotton swab.

- 13 . Use this cotton swab to polish the PID lamp window. Use a circular motion, applying light pressure to clean the lamp window. Do not touch the lamp window with your fingers.



Figure 27: Polishing the Electrode Lamp Window

- 14 . Continue polishing until you can hear a squeaking sound made by the cotton swab moving over the window surface. This usually occurs after about 15 seconds of polishing.
- 15 . Remove the residual powder from the lamp window with a clean cotton swab. Take care not to touch the tip of the cotton swab that is used to clean the lamp as this may contaminate it with finger oil.
- 16 . Ensure the lamp is completely dry and any visible signs of contamination are removed before reinstalling.
- 17 . Hold the electrode stack between the thumb and forefinger of one hand and place the window end of the lamp inside the O-ring seal in the electrode stack with the other hand as shown below.

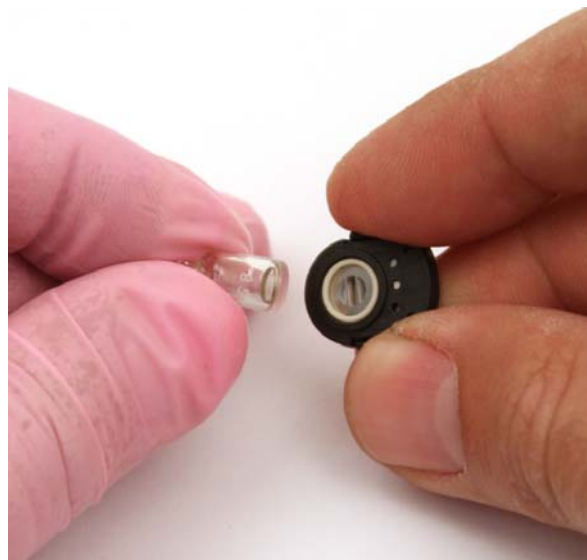

Figure 28: Reinstalling the Electrode Lamp

- 18 . Twisting the lamp slightly during insertion will help to ensure the lamp window is snug against the stack's front electrode. The lamp should be supported by the O-ring.
- 19 . Continuing to hold the electrode stack between your forefinger and thumb, carefully insert the lamp into the lamp cavity in the sensor ensuring that the lamp remains in position.
- 20 . Press in the electrode stack firmly to ensure that the stack wing clips are engaged and the faces of the stack and sensor body are flush.
- 21 . Carefully line up the PID sensor's connections with the connections on the bottom of the socket and slowly insert the sensor in the socket.
- 22 . Do not attempt to push the sensor in farther once it makes contact with the bottom of the socket until you are sure that the sensor's connections are engaged with the socket's connections. If you feel that the connections did not engage, slightly rotate the sensor back and forth without putting pressure on it until you feel the connections engage.
- 23 . Push the sensor into the socket until it bottoms out.
- 24 . Place the sensor gasket and filters back over the sensors ensuring that the sensor gasket seals with the sensors and the flow fittings. The flow fitting connections need to be facing up and cannot be skewed sideways. The gasket must be pushed down in the center and secured under the gasket aligning tabs.

Failure to install the sensor gasket appropriately may result in inaccurate gas readings.

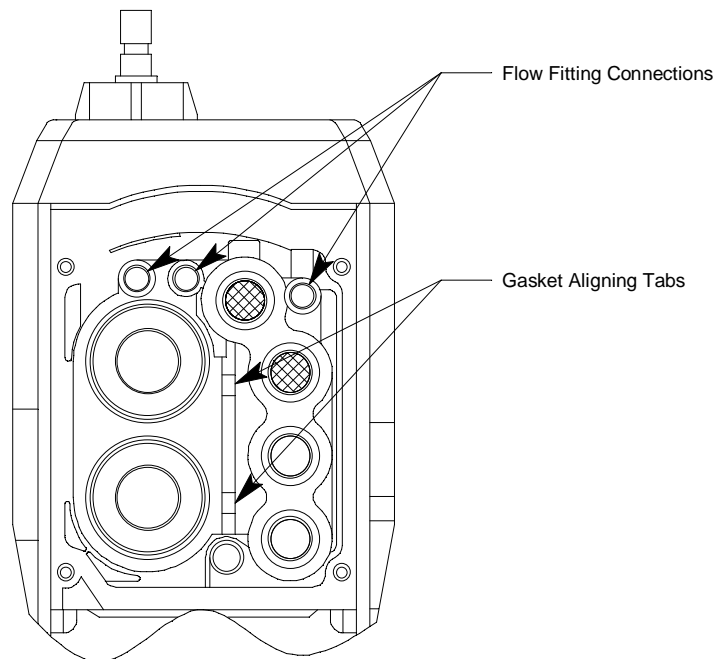

Figure 29: Sensor Gasket Seating

- 25 . Insert the flow chamber back into the instrument.
- 26 . Tighten the flow chamber's four screws that were loosened in Step 2.
- 27 . Start up the GX-6000 by pressing and briefly holding the POWER/ENTER button.

- 28 . To verify that the sensor gasket was inserted properly:
 - a. Plug the inlet with your finger.
 - b. Verify that the GX-6000 goes into low flow alarm. If the GX-6000 does not go into low flow alarm, turn the instrument off and attempt to seat the sensor gasket again.
- 29 . Calibrate the PID sensor as described in “Chapter 4: Calibration Mode” on page 58.

Replacing the PID Sensor’s Lamp

If cleaning the PID lamp does not resolve any calibration problems you may be having, the lamp may need to be replaced.

Ordering the Correct Replacement Lamp

It’s important to order the correct replacement lamp for your PID sensor.

- 1 . Look at the label(s) on the side of your PID sensor. Some sensors only have a label that says “PIS-001” or “PIS-002”. Other sensors have a label that says “PIS-001” or “PIS-002” and another RKI part number label that says “PID-001L” or “PID-002L”.
- 2 . See the table below for replacement lamp part numbers based on your sensor’s label(s).

Table 12: PID Sensor Replacement Lamp Part Number

Sensor Part Number	Part Number Label(s) on Sensor	Replacement Lamp Part Number
PID-001	PIS-001	51-1500RK
PID-001L	PIS-001 <u>and</u> PID-001L	51-1503
PID-002	PIS-002	51-1502
PID-002L	PIS-002 <u>and</u> PID-002L	51-1503

Steps to Replace the Lamp

Perform the following procedure to replace the PID lamp:

NOTE: Do not touch the new lamp window (the flat end) with your fingers as this may contaminate the window with finger oil.

- 1 . Verify that the GX-6000 is off.
- 2 . Use a small Phillips screwdriver to unscrew the four screws holding the flow chamber to the rest of the GX-6000’s case.
- 3 . Grasp the sides of the flow chamber and lift it away from the rest of the case. The screws are captive screws and will not come out of the flow chamber.
- 4 . Gently pull up the edges of the sensor gasket to loosen it from its connections. Be sure not to lose any of the filters that are in it. The sensor will be exposed.
- 5 . Grasp the PID sensor firmly and pull it out of its socket.
- 6 . Place the PID sensor face down on a flat clean working surface.

- 7 . Hold the PID sensor steady on the working surface with one hand and using the other hand, locate the tabs on the electrode stack removal tool and insert them into the slots on the side of the PID sensor near the face.



Figure 30: Using Removal Tool

- 8 . Squeeze the removal tool to push the tabs into the sensor slots until the electrode stack and lamp are released.
- 9 . Carefully lift the PID sensor body away from the electrode stack and lamp. If the lamp remains lodged in the sensor body, carefully remove it with tweezers.
- 10 . If the spring in the lamp cavity comes out, place it back into the lamp cavity.
- 11 . Discard the old PID lamp.

NOTE: At this point it is recommended that the finger cots be used on the fingers handling the lamp. Finger cots are included with the lamp cleaning kit.

- 12 . Hold the electrode stack between the thumb and forefinger of one hand and place the window end of the new lamp inside the O-ring seal in the electrode stack with the other hand as shown below. Take care not to touch the lamp window.

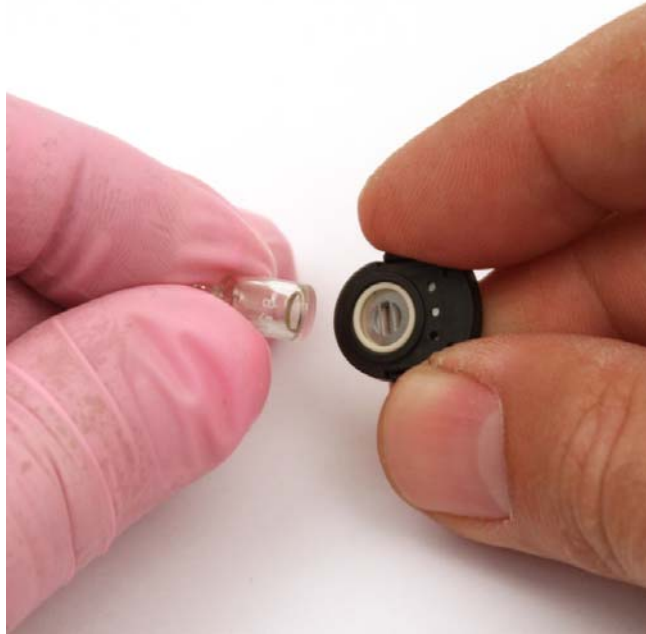

Figure 31: Reinstalling the Electrode Lamp

- 13 . Twisting the lamp slightly during insertion will help to ensure the lamp window is snug against the stack's front electrode. The lamp should be supported by the O-ring.
- 14 . Continuing to hold the electrode stack between your forefinger and thumb, carefully insert the lamp into the lamp cavity in the sensor ensuring that the lamp remains in position.
- 15 . Press in the electrode stack firmly to ensure that the stack wing clips are engaged and the faces of the stack and sensor body are flush.
- 16 . Carefully line up the PID sensor's connections with the connections on the bottom of the socket and slowly insert the sensor in the socket.
- 17 . Do not attempt to push the sensor in farther once it makes contact with the bottom of the socket until you are sure that the sensor's connections are engaged with the socket's connections. If you feel that the connections did not engage, slightly rotate the sensor back and forth without putting pressure on it until you feel the connections engage.
- 18 . Push the sensor into the socket until it bottoms out.
- 19 . Place the sensor gasket and filters back over the sensors ensuring that the sensor gasket seals with the sensors and the flow fittings. The flow fitting connections need to be facing up and cannot be skewed sideways. The gasket must be pushed down in the center and secured under the gasket aligning tabs.

Failure to install the sensor gasket appropriately may result in inaccurate gas readings.

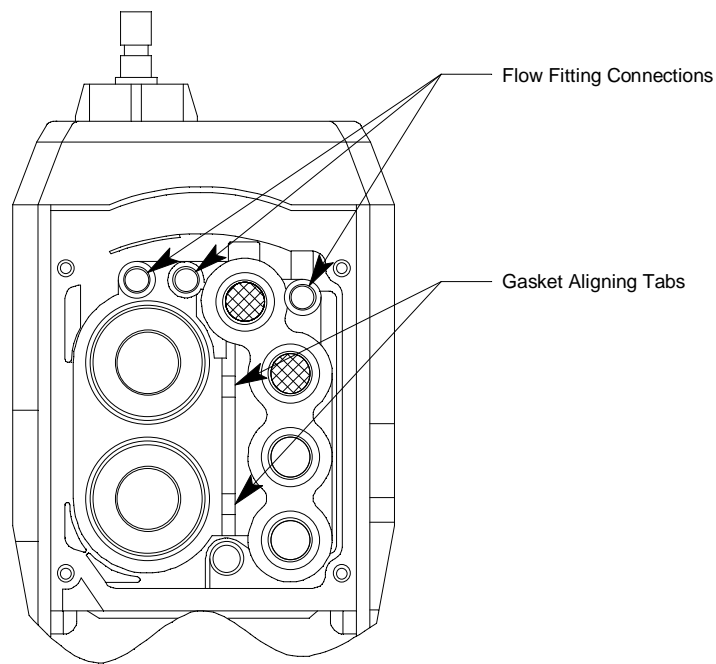

Figure 32: Sensor Gasket Seating

- 20 . Insert the flow chamber back into the instrument.
- 21 . Tighten the flow chamber's four screws that were loosened in Step 2.
- 22 . Start up the GX-6000 by pressing and briefly holding the POWER/ENTER button.
- 23 . To verify that the sensor gasket was inserted properly:
 - a. Plug the inlet with your finger.
 - b. Verify that the GX-6000 goes into low flow alarm. If the GX-6000 does not go into low flow alarm, turn the instrument off and attempt to seat the sensor gasket again.
- 24 . Calibrate the PID sensor as described in "Chapter 4: Calibration Mode" on page 58.

Replacing the PID Sensor's Electrode Stack

The electrode stack can last for the life of the PID sensor if the GX-6000 is used in a very clean, controlled environment. When used in a heavily contaminated or dirty environment, the electrode stack may only last a month. A contaminated electrode stack will cause a drop in sensitivity which can cause problems calibrating the PID channel. The electrode stack should be replaced if the PID sensor shows signs of contamination even after cleaning or replacing the lamp.

- 1 . Verify that the GX-6000 is off.
- 2 . Use a small Phillips screwdriver to unscrew the four screws holding the flow chamber to the rest of the GX-6000's case.
- 3 . Grasp the sides of the flow chamber and lift it away from the rest of the case. The screws are captive screws and will not come out of the flow chamber.
- 4 . Gently pull up the edges of the sensor gasket to loosen it from its connections. Be sure not to lose any of the filters that are in it. The sensor will be exposed.
- 5 . Grasp the PID sensor firmly and pull it out of its socket.

- 6 . Place the PID sensor face down on a flat clean working surface.

NOTE: Do not touch the lamp window with your fingers as this may contaminate the window with finger oil. At this point it is recommended that the finger cots be used on the fingers handling the lamp. Finger cots are included with the lamp cleaning kit.

- 7 . Hold the PID sensor steady on the working surface with one hand and using the other hand, locate the tabs on the electrode stack removal tool and insert them into the slots on the side of the PID sensor near the face.



Figure 33: Using Removal Tool

- 8 . Squeeze the removal tool to push the tabs into the sensor slots until the electrode stack and lamp are released.
- 9 . Carefully lift the PID sensor body away from the electrode stack and lamp. If the lamp remains lodged in the sensor body, carefully remove it with tweezers.
- 10 . If the spring in the lamp cavity comes out, place it back into the lamp cavity.
- 11 . Discard the old electrode stack.

- 12 . Hold the new electrode stack between the thumb and forefinger of one hand and place the window end of the lamp inside the O-ring seal in the new electrode stack with the other hand as shown below. Take care not to touch the lamp window.

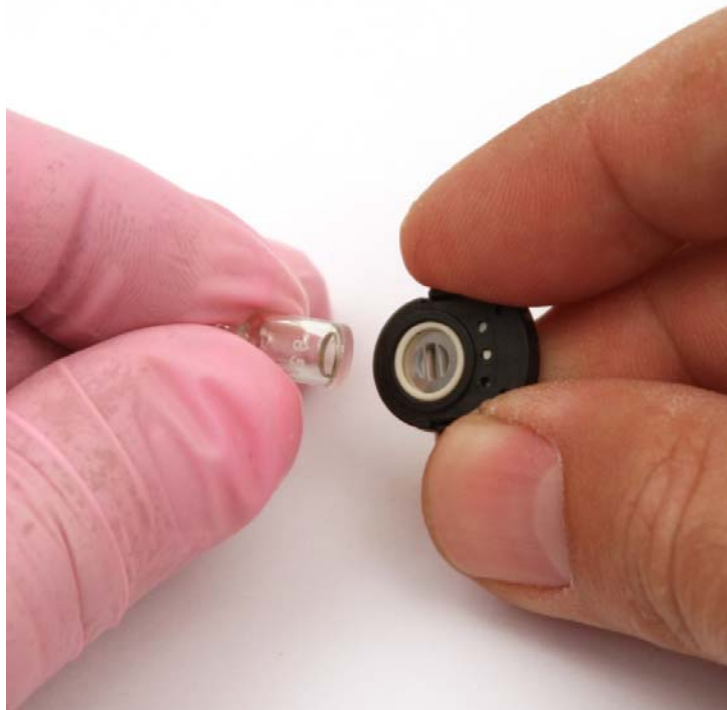

Figure 34: Reinstalling Electrode Lamp

- 13 . Twisting the lamp slightly during insertion will help to ensure the lamp window is snug against the stack's front electrode. The lamp should be supported by the O-ring.
- 14 . Continuing to hold the electrode stack between your forefinger and thumb, carefully insert the lamp into the lamp cavity in the sensor ensuring that the lamp remains in position.
- 15 . Press in the electrode stack firmly to ensure that the stack wing clips are engaged and the faces of the stack and sensor body are flush.
- 16 . Carefully line up the PID sensor's connections with the connections on the bottom of the socket and slowly insert the sensor in the socket.
- 17 . Do not attempt to push the sensor in farther once it makes contact with the bottom of the socket until you are sure that the sensor's connections are engaged with the socket's connections. If you feel that the connections did not engage, slightly rotate the sensor back and forth without putting pressure on it until you feel the connections engage.
- 18 . Push the sensor into the socket until it bottoms out.
- 19 . Place the sensor gasket and filters back over the sensors ensuring that the sensor gasket seals with the sensors and the flow fittings. The flow fitting connections need to be facing up and cannot be skewed sideways. The gasket must be pushed down in the center and secured under the gasket aligning tabs.

Failure to install the sensor gasket appropriately may result in inaccurate gas readings.

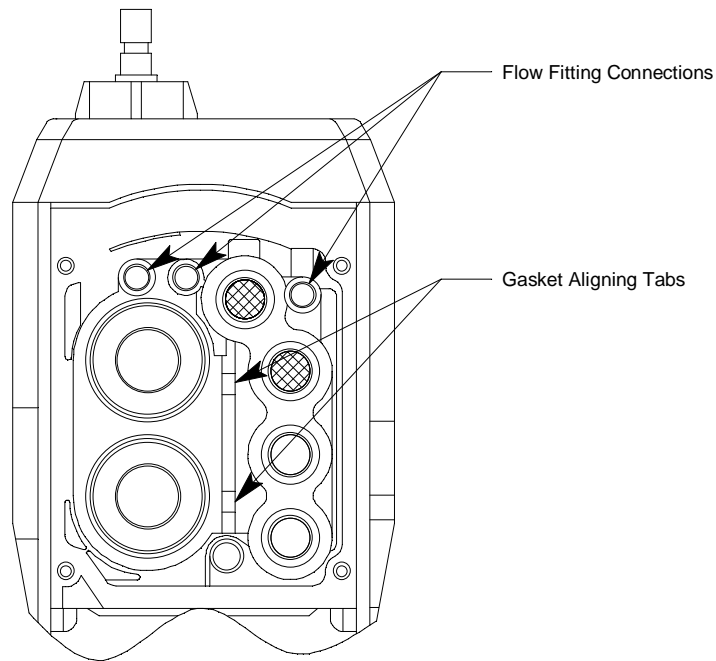

Figure 35: Sensor Gasket Seating

- 20 . Insert the flow chamber back into the instrument.
- 21 . Tighten the flow chamber's four screws that were loosened in Step 2.
- 22 . Start up the GX-6000 by pressing and briefly holding the POWER/ENTER button.
- 23 . To verify that the sensor gasket was inserted properly:
 - a. Plug the inlet with your finger.
 - b. Verify that the GX-6000 goes into low flow alarm. If the GX-6000 does not go into low flow alarm, turn the instrument off and attempt to seat the sensor gasket again.
- 24 . Calibrate the PID sensor as described in "Chapter 4: Calibration Mode" on page 58.

Chapter 7: General Parts List

Table 13 lists part numbers for the GX-6000's replacement parts and accessories.

Table 13: General Parts List

Part Number	Description
06-1248RK-03	Calibration kit tubing, 3 foot length
10-1093RK	Screw, for flow chamber
13-0112RK	Wrist strap
13-0123	Belt clip
13-6022	DIN rail, 4" long
13-6022-01	DIN rail mounting kit for 1 charger, includes 4" DIN rail and 2 end clamps
13-6025	DIN rail, 14" long
13-6025-01	DIN rail mounting kit for 4 chargers, includes 14" DIN rail and 2 end clamps
13-6100	End clamp for DIN rail mounting of charger
17-1031RK	Tapered rubber nozzle, red
20-0329	Rubber boot, red
21-1833RK	Filter holder, clear plastic
33-0159RK	Hydrophobic filter, for instrument inlet and for probe
33-0560RK	PID sensor electrode stack, 0 - 50,000 ppb, 2 stacks
33-0560-01	PID sensor electrode stack, 0 - 50,000 ppb, 1 stack
33-0562	PID sensor electrode stack, 0 - 6,000 ppm, HPPM type
33-1112RK	Wire mesh disk filter, for instrument inlet
33-3013	Particle filter for probe
33-6092	VOC zero filter, charcoal, with tubing stubs and plugs (included with low-range PID units, 10.0 eV/benzene units, and 11.7 eV PID units; optional for high-range PID units)
47-5084RK	USB/IrDA adapter module, Legasic, for use with all premier portables (without USB cable)
47-5084RK-01	USB/IrDA adapter assembly, Legasic, for use with all premier portables (with module and USB cable)
47-5085RK	Cable, USB A to USB mini, 6 feet, for 47-5084RK USB/IrDA adapter module
47-5093	USB/IrDA adapter with cable and CD (not for use with Eagle 2)
49-0115RK	AC adapter
49-1120RK	AA size alkaline battery
49-1619	Li-ion battery pack

Table 13: General Parts List (cont.)

Part Number	Description
49-1620	Alkaline battery pack
49-2182-01	Battery charger, BC-6000, with 100 - 240 VAC adapter
49-2183	Battery charger, BC-6000, with 12 VDC adapter
51-1500RK	PID sensor replacement lamp, 0 - 50,000 ppb, for PID-001 sensor
51-1502	PID sensor replacement lamp, 0 - 6,000 ppm, HPPM type, for PID-002 sensor
51-1502-01	PID sensor replacement lamp/electrode stack set, 0 - 6,000 ppm, HPPM type, for PID-002 sensor
51-1503	PID sensor replacement lamp, for PID-001L and PID-002L sensor
65-7001RK	Dummy sensor, LEL, O ₂ , CO, or H ₂ S sensor position
65-7003	Dummy sensor, smart sensor position
71-0363	Operator's Manual, GX-6000 Single Sensor PID Model (this document)
71-0383	Operator's Manual, GX-6000 Data Logger Management Program
71-8010	GX-6000 Product CD, includes Data Logger Management Program, User Setup Program, and all operator's manuals
80-0006-XXP	Sample hose with integral probe, with hydrophobic filter and particle filter, no scrubber section. Replace "XX" with length in feet. 3 foot hose is standard. Available lengths for the GX-6000 are 3, 5, 10, 15, 20, 25, 30, 35, 40, 45, and 50 feet.
80-0172	Probe, with hydrophobic filter and particle filter, no scrubber section
81-0103RK-04	Calibration cylinder, isobutylene, 100 ppm in air, 34 liter aluminum
81-0104RK-04	Calibration cylinder, isobutylene, 10 ppm in air, 34 liter aluminum
81-1054RK	Regulator, demand-flow type (for 58- and 103-liter aluminum or steel, and 34-liter aluminum calibration cylinders)
81-1055RK	Regulator, demand-flow type (for 17- and 34-liter steel cylinder)
81-6AAX-DLV	Calibration kit: 34 liter four-gas (CH ₄ /O ₂ /H ₂ S/CO) cylinder, 34 liter 10 ppm IBL in air cylinder, demand flow regulator, calibration tubing
81-6XAX-DLV	Calibration kit: 34 liter 10 ppm IBL in air cylinder, demand flow regulator, calibration tubing
81-6XBX-DLV	Calibration kit: 34 liter 100 ppm IBL in air cylinder, demand flow regulator, calibration tubing
82-0003RK	Electrode stack removal tool
82-0300RK	Aluminum oxide powder PID lamp cleaning kit, with electrode stack removal tool, for 10.0 eV and 10.6 eV PID sensors' lamps ONLY
82-0301	Anhydrous methanol PID lamp cleaning kit, with electrode stack removal tool, for 11.7 eV PID sensors' lamps ONLY
PID-001L	PID sensor, 0 - 50,000 ppb VOC, improved type

Table 13: General Parts List (cont.)

Part Number	Description
PID-002L	PID sensor, 0 - 6,000 ppm VOC, improved type

Appendix A: Maintenance Mode

Overview

This appendix describes the GX-6000 in Maintenance Mode. The GX-6000 is factory-set to suit most applications. Update settings in Maintenance Mode only if required for your specific application. Maintenance Mode items and their factory settings are listed in Table 14 below.

Table 14: Maintenance Mode Menu Items

Menu Item (Page # of Description)		Choices or Action	Factory Setting	
DATE (pg.118)		user-entered date/time	current date/time	
DATE FORMAT (pg.118)		<ul style="list-style-type: none"> • DD/MM/YYYY • MM/DD/YYYY • YYYY/MM/DD 	MM/DD/YYYY	
GAS CALIBRATION (pg.119)		perform a calibration	N/A	
BUMP TEST (pg.119)		perform a bump test	N/A	
CAL SETTING (pg.120)	CAL REMINDER (pg.120)	<ul style="list-style-type: none"> • ON • OFF 	ON	
	CAL INTERVAL (pg.120)	1-365 DAYS	90 DAYS	
	CAL EXPRD (pg.121)	<ul style="list-style-type: none"> • CONFIRM TO USE • CANNOT USE • NO EFFECT 	CONFIRM TO USE	
	CAL CHECK GAS (pg.121)	<ul style="list-style-type: none"> • 4 GAS • ALL GAS 	ALL GAS	
	ESCAPE	return to main menu	N/A	
BUMP SETTING (pg.122)	BUMP DISP (pg.122)	<ul style="list-style-type: none"> • ON • OFF 	OFF	
	BUMP PARAMETERS (pg.123)	GAS TIME (pg.123)	<ul style="list-style-type: none"> • 30 SEC • 45 SEC • 60 SEC • 90 SEC 	30 SEC
		CHECK (pg.123)	<ul style="list-style-type: none"> • 10% • 20% • 30% • 40% • 50% 	30%
		CAL TIME (pg.123)	<ul style="list-style-type: none"> • 90 SEC • 120 SEC 	90 SEC
		AUTO CAL (pg.124)	<ul style="list-style-type: none"> • ON • OFF 	ON

Table 14: Maintenance Mode Menu Items

Menu Item (Page # of Description)		Choices or Action	Factory Setting	
BUMP SETTING (cont'd)	BUMP PARAMETERS (cont'd)	ESCAPE	return to BUMP PARAMETERS menu	N/A
	BUMP REMINDER (pg.124)		<ul style="list-style-type: none"> • ON • OFF 	OFF
	BUMP INTERVAL (pg.124)		0-30 DAYS	30 DAYS
	BUMP EXPRD (pg.125)		<ul style="list-style-type: none"> • CONFIRM TO USE • CANNOT USE • NO EFFECT 	CONFIRM TO USE
	BUMP CHECK GAS (pg.125)		<ul style="list-style-type: none"> • 4 GAS • ALL GAS 	ALL GAS
	ESCAPE		return to main menu	N/A
ALARM SETTING (pg.126)	ALARM POINTS (pg.126)		set alarm points	see Table 1 on page 9
	ALARM LATCHING (pg.127)		<ul style="list-style-type: none"> • LATCHING • SELF RESET 	LATCHING
	ALARM SILENCE (pg.127)		<ul style="list-style-type: none"> • ON • OFF 	ON
	ESCAPE		return to main menu	N/A
PUMP OFF DISP (pg.128)		<ul style="list-style-type: none"> • ON • OFF 	OFF	
ID DISPLAY (pg.128)		<ul style="list-style-type: none"> • ON • OFF 	OFF	
BACK LIGHT TIME (pg.128)		OFF - 255 SEC	30 SEC	
LANGUAGE (pg.129)		<ul style="list-style-type: none"> • ENGLISH • JAPANESE • ITALIAN • SPANISH • GERMAN • FRENCH • PORTUGUESE • RUSSIAN • KOREAN 	ENGLISH	
LUNCH BREAK (pg.129)		<ul style="list-style-type: none"> • ON • OFF 	OFF	
AUTO ZERO (pg.130)		<ul style="list-style-type: none"> • ON • OFF 	OFF	
DEMAND ZERO (pg.130)		<ul style="list-style-type: none"> • ON • OFF 	ON	

Table 14: Maintenance Mode Menu Items

Menu Item (Page # of Description)		Choices or Action	Factory Setting
ZERO FOLLOWER (pg.130)		<ul style="list-style-type: none"> • ON • OFF 	ON
ZERO SUPPRESS (pg.130)		0 - 3% of full scale	0% of full scale*
IR AUTO RANGE (pg.130)		N/A	N/A
CONFIRMATION (pg.131)		<ul style="list-style-type: none"> • ON • OFF 	OFF
	CONFIRMATION INTERVAL (if CONFIRMATION set to ON)	1 - 60 MIN	5 MIN
KEY TONE (pg.131)		<ul style="list-style-type: none"> • ON • OFF 	ON
INERT MODE (pg.132)		N/A	N/A
L. /B. MODE (pg.132)		N/A	N/A
BAR HOLE TIME (pg.132)		N/A	N/A
CO DISPLAY (pg.132)		N/A	N/A
MAN DOWN (pg.132)	MAN DOWN (pg.132)	<ul style="list-style-type: none"> • ON • OFF 	OFF
	PANIC (pg.133)	<ul style="list-style-type: none"> • ON • OFF 	ON
	WARNING 1 TIME (pg.133)	10 - 75 SEC	60 SEC
	WARNING 2 TIME (pg.133)	60 - 90 SEC	75 SEC
	ALARM TIME (pg.133)	75 - 120 SEC	90 SEC
	ESCAPE	return to main menu	N/A
LOG SETTING (pg.134)	LOG INTERVAL (pg.134)	<ul style="list-style-type: none"> • 10 SEC • 20 SEC • 30 SEC • 60 SEC • 120 SEC • 180 SEC • 300 SEC • 600 SEC 	300 SEC
	LOG CLEAR DISP (pg.135)	<ul style="list-style-type: none"> • ON • OFF 	ON
	LOG OVER WRITE (pg.134)	<ul style="list-style-type: none"> • ON • OFF 	ON
	ESCAPE	return to main menu	N/A
FLOW ADJUST (pg.135)		set the low flow alarm	N/A

Table 14: Maintenance Mode Menu Items

Menu Item (Page # of Description)	Choices or Action	Factory Setting
ROM/SUM (pg.136)	view the ROM number and checksum	N/A
PASSWORD (pg.137)	<ul style="list-style-type: none"> • ON • OFF 	ON (0006)
RESTORE DEFAULT (pg.137)	restore default settings	N/A
START MEASURE (pg.138)	enter Measuring Mode	N/A
* PID channel's zero suppression is always 0% regardless of what value is shown.		

Entering Maintenance Mode

WARNING: *The GX-6000 is not in operation as a gas detector while in Maintenance Mode.*

1. Take the GX-6000 to a non-hazardous location and turn it off if it is on.
2. Press and hold the ▲AIR and SHIFT ▼(PANIC) buttons, then press and hold the POWER/ENTER button. When you hear a beep, release the buttons.
3. The screen that appears will depend on the setting of User Mode's **PASSWORD** item.

If User Mode's **PASSWORD** is set to **OFF** (factory setting), continue with Step 4.

If User Mode's **PASSWORD** is set to **ON**, continue with Step 6.

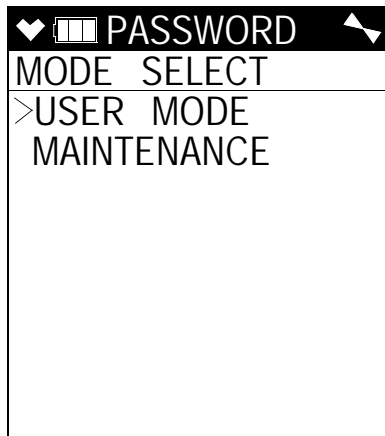

User **PASSWORD OFF**
Maint. **PASSWORD ON**
 or **OFF**

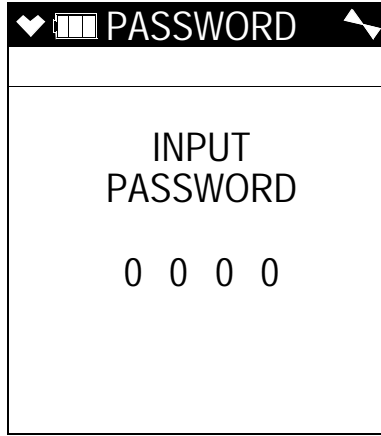

User **PASSWORD ON**
Maint. **PASSWORD ON**

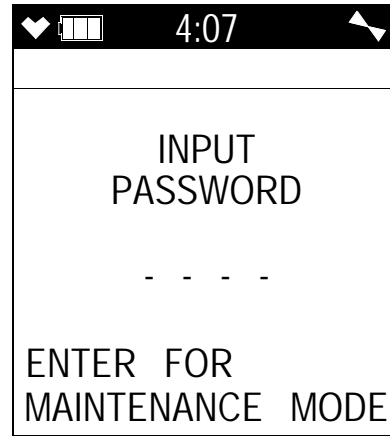

User **PASSWORD ON**
Maint. **PASSWORD OFF**

4. If User Mode's **PASSWORD** has been set to **OFF**, the Mode Select screen will appear, prompting you to choose the mode you'd like to enter.
5. Use the ▲AIR and SHIFT ▼(PANIC) buttons to put the cursor in front of **MAINTENANCE** and press and release the POWER/ENTER button. A password screen will appear. Continue to Step 7.

6. If User Mode's **PASSWORD** has been set to **ON**, a password screen will appear.
7. The appearance of the password screen will be affected by Maintenance Mode's **PASSWORD** setting.

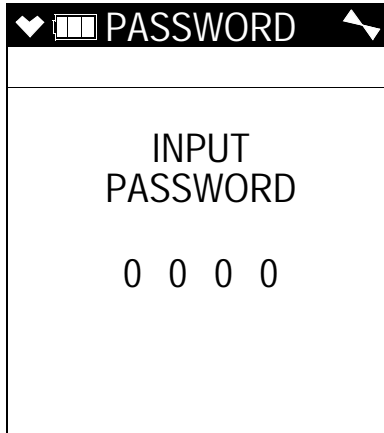

Maint. **PASSWORD** set to **ON**

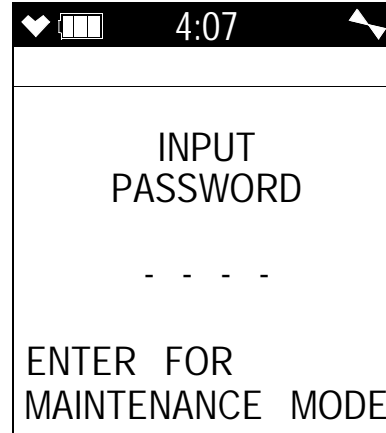

Maint. **PASSWORD** set to **OFF**

8. If Maintenance Mode's **PASSWORD** is set to **OFF**, continue to Step 11.
9. If Maintenance Mode's **PASSWORD** is set to **ON** (factory setting), enter the password by using the **▲AIR** and **SHIFT ▼(PANIC)** buttons to select each password number and then pressing and releasing the **POWER/ENTER** button to enter it and move on to the next number until all of the numbers are entered. The password is 0006.
10. If you enter an incorrect password, an error screen will appear.

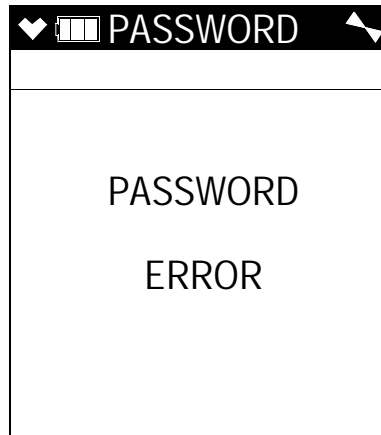

You must turn the unit off and reenter Maintenance Mode using the correct password. Continue to Step 12.

11. If Maintenance Mode's **PASSWORD** is set to **OFF**, press and release the **POWER/ENTER** button to enter Maintenance Mode. There is no need to enter a password. The password screen appears even if **PASSWORD** is set to **OFF** so that a special factory mode can be accessed, if necessary.

12 . The main menu displays. It displays eight menu items at a time.

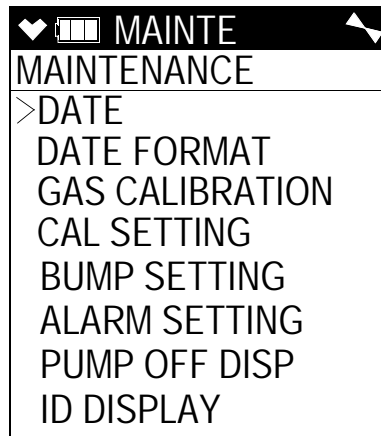

13 . Use the ▲AIR or SHIFT ▼ (PANIC) button to move the cursor up and down through the menu items. Additional items are available above and below the items currently displayed on the screen. They will appear as you scroll farther up or down the current list using the ▲AIR or SHIFT ▼ (PANIC) buttons.

Tips for Using Maintenance Mode

- When in the main menu, the cursor (>) indicates which menu item will be selected if the POWER/ENTER button is pressed and released.
- Use the SHIFT ▼ (PANIC) button to move the cursor down through the main menu and submenu items, and to lower values or change the setting in a specific option.
- Use the ▲AIR button to move the cursor up through the main menu and submenu items, and to raise values or change the setting in a specific option.
- Use the POWER/ENTER button to enter a menu item with the cursor next to it and to enter and save settings during programming.
- An adjustable parameter that is flashing can be adjusted with the ▲AIR and SHIFT ▼ (PANIC) buttons.
- Press the DISP/LOCK button while in a screen where you are entering or updating parameters to exit the screen without saving any changes. You can also use the DISP/LOCK button to back out of submenus and return to the main menu.

Setting the Date and Time (DATE)

1. From the main menu, place the cursor next to **DATE**.
2. Press and release POWER/ENTER. The date and time will be displayed with the year flashing.

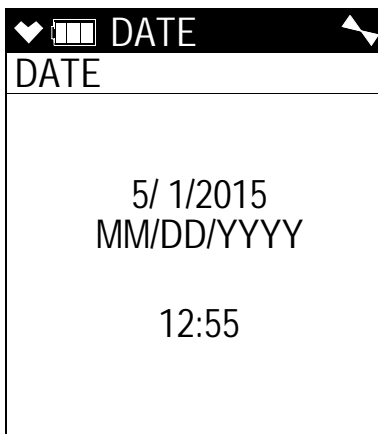

3. Use ▲AIR or SHIFT ▼ (PANIC) to display the desired year.
4. Press and release POWER/ENTER to save the setting. The month setting flashes.
5. Repeat Step 3 and Step 4 to enter the month, day, hours, and minutes settings. The main menu displays after you enter the seconds setting.

Setting the Date Format (DATE FORMAT)

The date can be displayed in three ways, **MM/DD/YYYY** (factory setting), **DD/MM/YYYY**, or **YYYY/MM/DD**.

1. From the main menu, place the cursor next to **DATE FORMAT**.
2. Press and release POWER/ENTER. The Date Format screen appears with the current setting displayed.
3. Use ▲AIR or SHIFT ▼ (PANIC) to display the desired setting.
4. Press and release POWER/ENTER to save the setting and return to the main menu.

Performing a Calibration (GAS CALIBRATION)

1. From the main menu, place the cursor next to **GAS CALIBRATION**.
2. Press and release **POWER/ENTER**. The Gas Calibration Screen appears.

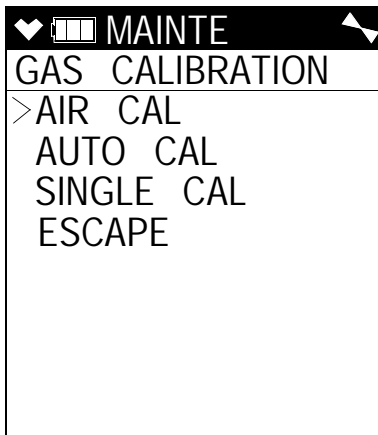

3. Use the **▲AIR** or **SHIFT ▼ (PANIC)** buttons to move the cursor to the operation you wish to perform.

See “Calibrating Using the Auto Calibration Method” on page 59 for instructions to perform an automatic calibration.

See “Calibrating Using the Single Calibration Method” on page 67 for instructions to perform a single calibration.

Performing a Bump Test (BUMP TEST)

NOTE: The **BUMP DISP** menu item in Maintenance Mode is factory set to **OFF**. The **BUMP TEST** menu item will not appear unless **BUMP DISP** is set to **ON**. See “Updating the Bump Display Setting (BUMP DISP)” on page 122 for instructions.

Entering the **BUMP TEST** menu item brings you to the first of the Gas Select Screens. See “Performing a Bump Test” on page 72 for instructions, starting at Step 8.

Updating Calibration Settings (CAL SETTING)

The **CAL SETTING** menu item in Maintenance Mode has a sub menu with 5 menu items: **CAL REMINDER**, **CAL INTERVAL**, **CAL EXPRD**, **CAL CHECK GAS**, and **ESCAPE**.

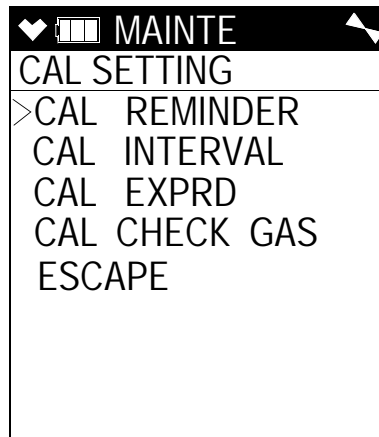

1. From the main menu, place the cursor next to **CAL SETTING**.
2. Press and release POWER/ENTER. The **CAL SETTING** menu appears.

Updating the Calibration Reminder Setting (CAL REMINDER)

With **CAL REMINDER** set to **ON** (factory setting), the GX-6000 will give an indication at start up if it is due for calibration. The type of indication will depend on the **CAL EXPRD** setting (see “Updating the Calibration Expired Setting (CAL EXPRD)” on page 121).

With **CAL REMINDER** set to **OFF**, the GX-6000 will not give an indication at start up if it is due for calibration.

1. From the **CAL SETTING** screen, place the cursor next to **CAL REMINDER**.
2. Press and release POWER/ENTER. The Calibration Reminder Screen appears.
3. Use ▲AIR or SHIFT ▼(PANIC) to display the desired setting.
4. Press and release POWER/ENTER to save the setting and return to the **CAL SETTING** menu.

Updating the Calibration Interval (CAL INTERVAL)

This setting defines the amount of time between calibrations. The time can be set in 1 day increments. The minimum setting is 1 day and the maximum setting is 365 days. The factory setting is 90 days.

1. From the **CAL SETTING** screen, place the cursor next to **CAL INTERVAL**.
2. Press and release POWER/ENTER. The Set Calibration Interval Screen appears.
3. Use ▲AIR or SHIFT ▼(PANIC) to display the desired setting.

Tip: Press and hold ▲AIR or SHIFT ▼(PANIC) to rapidly scroll through the settings.

4. Press and release POWER/ENTER to save the setting and return to the **CAL SETTING** menu.

Updating the Calibration Expired Setting (CAL EXPRD)

This item defines what indication is given during start up when calibration is due and **CAL REMINDER** is set to **ON**.

With **CAL EXPRD** set to **CONFIRM TO USE** (factory setting), the GX-6000 will give an indication at start up if calibration is past due and will require the user to decide whether to perform a calibration or continue and use the GX-6000 without calibrating. Press and release **DISP/LOCK** to continue without calibrating or **POWER/ENTER** to perform a calibration.

With **CAL EXPRD** set to **CANNOT USE**, if the unit is due for calibration, the GX-6000 will give an indication at start up that calibration is past due and will prompt you to press and release **POWER/ENTER** to enter Calibration Mode and perform a calibration. Using any other button will have no effect. A successful calibration must be performed in order to use the instrument.

NOTE: Even if the password function is turned on in **PASSWORD**, no password will be required to perform a calibration during startup.

With **CAL EXPRD** set to **NO EFFECT**, the GX-6000 will give an indication at startup that calibration is past due. If desired, the **POWER/ENTER** button can be pressed to enter Calibration Mode and perform a calibration but it is not necessary to acknowledge the calibration due indication. The warm-up sequence will continue on its own.

1. From the **CAL SETTING** screen, place the cursor next to **CAL EXPRD**.
2. Press and release **POWER/ENTER**. The Calibration Expired Screen appears.
3. Use **▲AIR** or **SHIFT ▼(PANIC)** to display the desired setting.
4. Press and release **POWER/ENTER** to save the setting and return to the **CAL SETTING** menu.

Updating the Calibration Check Gas Setting (CAL CHECK GAS)

For this version of the GX-6000, the **CAL CHECK GAS** parameter needs to be set to **ALL GAS**. It is not recommended that this parameter be changed.

Returning to the Maintenance Mode Menu (ESCAPE)

1. From the **CAL SETTING** screen, place the cursor next to **ESCAPE**.
2. Press and release **POWER/ENTER**. The instrument will return to the main menu.

Updating Bump Test Settings (BUMP SETTING)

The **BUMP SETTING** menu item in Maintenance Mode has a sub menu with 7 menu items: **BUMP DISP**, **BUMP PARAMETERS**, **BUMP REMINDER**, **BUMP INTERVAL**, **BUMP EXPRD**, **BUMP CHECK GAS**, and **ESCAPE**.

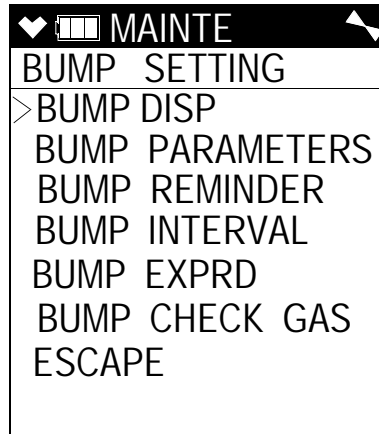

1. From the main menu, place the cursor next to **BUMP SETTING**.
2. Press and release POWER/ENTER. The **BUMP SETTING** menu appears.

Updating the Bump Display Setting (BUMP DISP)

With **BUMP DISP** set to **ON**, the **BUMP TEST** menu item will appear in Calibration Mode.

NOTE: **BUMP DISP** must be set to **ON** to have the GX-6000's bump test date reset after a successful bump test in an SDM-6000.

With **BUMP DISP** set to **OFF** (factory setting), the **BUMP TEST** menu item will not appear in Calibration Mode.

1. From the **BUMP SETTING** screen, place the cursor next to **BUMP DISP**.
2. Press and release POWER/ENTER. The Bump Display Screen appears.
3. Use ▲AIR or SHIFT ▼(PANIC) to display the desired setting.
4. Press and release POWER/ENTER to save the setting and return to the **BUMP SETTING** menu.

Updating the Bump Parameters

The **BUMP PARAMETERS** menu item in the Bump Test Settings sub-menu has its own sub-menu with 5 menu items: **GAS TIME**, **CHECK**, **CAL TIME**, **AUTO CAL**, and **ESCAPE**.

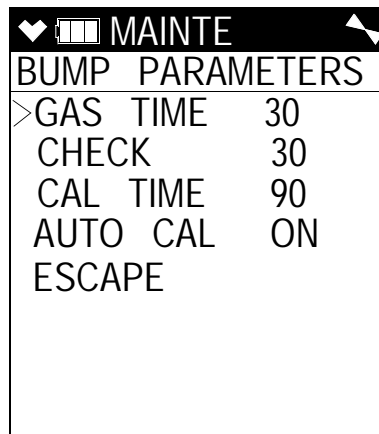

The screenshot shows a menu interface. At the top, there is a header bar with a downward arrow, a battery icon, and the text 'MAINTENANCE'. Below this, the 'BUMP PARAMETERS' menu is displayed. The items listed are: '>GAS TIME 30', 'CHECK 30', 'CAL TIME 90', 'AUTO CAL ON', and 'ESCAPE'. The '>' symbol next to 'GAS TIME' indicates it is the currently selected item.

MAINTENANCE	
BUMP PARAMETERS	
>GAS TIME	30
CHECK	30
CAL TIME	90
AUTO CAL	ON
ESCAPE	

1. From the **BUMP SETTING** screen, place the cursor next to **BUMP PARAMETERS**.
2. Press and release POWER/ENTER. The Bump Parameters Menu Screen appears.

Updating the GAS TIME Setting

The **GAS TIME** is the amount of time that the instrument is exposed to gas during a bump test. The available choices are 30 seconds (factory setting), 45 seconds, 60 seconds, and 90 seconds.

1. From the **BUMP PARAMETERS** screen, place the cursor next to **GAS TIME**.
2. Press and release POWER/ENTER. The current Gas Time value will begin to flash.
3. Use ▲AIR or SHIFT ▼ (PANIC) to display the desired setting.
4. Press and release POWER/ENTER to save the setting. The value will stop flashing.

Updating the CHECK Setting

The **CHECK** is the bump test tolerance value and is represented as a percentage. It is the percentage that the bump test reading can differ from the actual gas concentration. If the bump test reading differs more, the bump test will fail. The available values are 10%, 20% 30% (factory setting), 40%, and 50%.

1. From the **BUMP PARAMETERS** screen, place the cursor next to **CHECK**.
2. Press and release POWER/ENTER. The current Check value will begin to flash.
3. Use ▲AIR or SHIFT ▼ (PANIC) to display the desired setting.
4. Press and release POWER/ENTER to save the setting. The value will stop flashing.

Updating the CAL TIME Setting

The **CAL TIME** is the total time the instrument is exposed to calibration gas when a bump test fails if **AUTO CAL** is set to **ON**. The bump test time is deducted from the calibration time. For example, if the **CAL TIME** is set to 90 seconds and the **GAS TIME** is set to 30 seconds, if the bump test fails, the GX-6000 will only be exposed to gas for an additional 60 seconds. The available values are 90 seconds (factory setting), and 120 seconds.

1. From the **BUMP PARAMETERS** screen, place the cursor next to **CAL TIME**.

2. Press and release POWER/ENTER. The current Cal Time value will begin to flash.
3. Use ▲AIR or SHIFT ▼(PANIC) to display the desired setting.
4. Press and release POWER/ENTER to save the setting. The value will stop flashing.

Updating the AUTO CAL Setting

With **AUTO CAL** set to **ON** (factory setting), if a bump test fails, the unit will automatically begin a calibration. If **AUTO CAL** is set to **OFF** and a bump test fails, nothing will happen.

1. From the **BUMP PARAMETERS** screen, place the cursor next to **AUTO CAL**.
2. Press and release POWER/ENTER. The current Auto Cal setting will begin to flash.
3. Use ▲AIR or SHIFT ▼(PANIC) to display the desired setting.
4. Press and release POWER/ENTER to save the setting. The setting will stop flashing.

Returning to the BUMP SETTINGS Menu

1. From the **BUMP PARAMETERS** screen, place the cursor next to **ESCAPE**.
2. Press and release POWER/ENTER. The instrument will return to the **BUMP SETTING** screen.

Updating the Bump Reminder Setting (BUMP REMINDER)

With **BUMP REMINDER** set to **ON**, the GX-6000 will give an indication at start up if it is due for bump testing. The type of indication will depend on the **BUMP EXPRD** setting (see “Updating the Bump Expired Setting (BUMP EXPRD)” on page 125).

NOTE: If **BUMP REMINDER** is set to **ON** but **BUMP DISP** is set to **OFF**, the instrument will alert you if a bump test is due but the bump test item will not appear in Calibration Mode.

With **BUMP REMINDER** set to **OFF** (factory setting), the GX-6000 will not give an indication at start up if it is due for bump testing.

1. From the **BUMP SETTING** screen, place the cursor next to **BUMP REMINDER**.
2. Press and release POWER/ENTER. The current Bump Reminder setting will be displayed.
3. Use ▲AIR or SHIFT ▼(PANIC) to display the desired setting.
4. Press and release POWER/ENTER to save the setting. The instrument will return to the **BUMP SETTING** screen.

Updating the Bump Interval (BUMP INTERVAL)

This setting defines the amount of time between bump tests. The time can be set in 1 day increments. The minimum setting is 0 days and the maximum setting is 30 days. The factory setting is 30 days.

1. From the **BUMP SETTING** screen, place the cursor next to **BUMP INTERVAL**.
2. Press and release POWER/ENTER. The current Bump Interval setting will be displayed.
3. Use ▲AIR or SHIFT ▼(PANIC) to display the desired setting.
4. Press and release POWER/ENTER to save the setting. The instrument will return to the **BUMP SETTING** screen.

Updating the Bump Expired Setting (BUMP EXPRD)

This item defines what indication is given during start up when a bump test is due and **BUMP REMINDER** is set to **ON**.

With **BUMP EXPRD** set to **CONFIRM TO USE** (factory setting), the GX-6000 will give an indication at start up if a bump test is past due and will require the user to decide whether to perform a bump test or continue and use the GX-6000 without bump testing. Press and release **RESET** to continue without calibrating or **POWER/ENTER** to enter Calibration Mode.

With **BUMP EXPRD** set to **CANNOT USE**, if the unit is due for bump testing, the GX-6000 will give an indication at start up that a bump test is past due and will prompt you to press and release **POWER/ENTER** to enter Calibration Mode and perform a bump test. Using any other button will have no effect. A successful bump test must be performed in order to use the instrument.

NOTE: Even if the password function is turned on in **PASSWORD**, no password will be required to perform a bump test during startup.

NOTE: If **BUMP DISP** is set to **OFF**, the bump test menu item will not appear in Calibration Mode even though the instrument is prompting you to perform a bump test. A bump test can always be performed in Maintenance Mode, if necessary.

With **BUMP EXPRD** set to **NO EFFECT**, the GX-6000 will give an indication at startup that a bump test is past due. If desired, the **POWER/ENTER** button can be pressed to enter Calibration Mode and perform a bump test but it is not necessary to acknowledge the bump test due indication. The warm-up sequence will continue on its own.

1. From the **BUMP SETTING** screen, place the cursor next to **BUMP EXPRD**.
2. Press and release **POWER/ENTER**. The current Bump Expired setting will be displayed.
3. Use **▲AIR** or **SHIFT ▼(PANIC)** to display the desired setting.
4. Press and release **POWER/ENTER** to save the setting. The instrument will return to the **BUMP SETTING** screen.

Updating the Bump Check Gas Setting (BUMP CHECK GAS)

For this version of the GX-6000, the **BUMP CHECK GAS** parameter needs to be set to **ALL GAS**. It is not recommended that this parameter be changed.

Returning to the Maintenance Mode Menu (ESCAPE)

1. From the **BUMP SETTING** screen, place the cursor next to **ESCAPE**.
2. Press and release **POWER/ENTER**. The instrument will return to the main menu.

Updating Alarm Parameters (ALARM SETTING)

The **ALARM SETTING** menu item in Maintenance Mode has a sub menu with 4 menu items: **ALARM POINTS**, **ALARM LATCHING**, **ALARM SILENCE**, and **ESCAPE**.

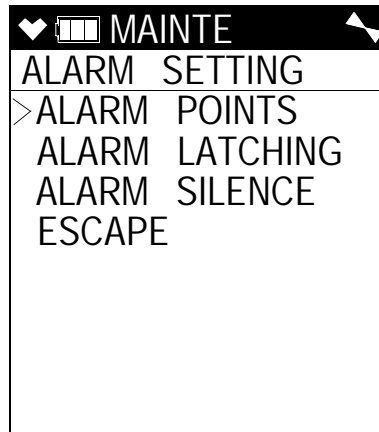

1. From the main menu, place the cursor next to **ALARM SETTING**.
2. Press and release POWER/ENTER. The **ALARM SETTING** menu appears.

Updating the Alarm Point Settings (ALARM POINTS)

This menu item allows you to update one or more alarm points (the reading at which the GX-6000 recognizes the alarm condition). See Table 1 on page 9 for alarm point factory settings.

1. From the **ALARM SETTING** menu, place the cursor next to **ALARM POINTS**.
2. Press and release POWER/ENTER. The Alarm Points Screen appears and the cursor will be next to the VOC channel since it's the only channel.

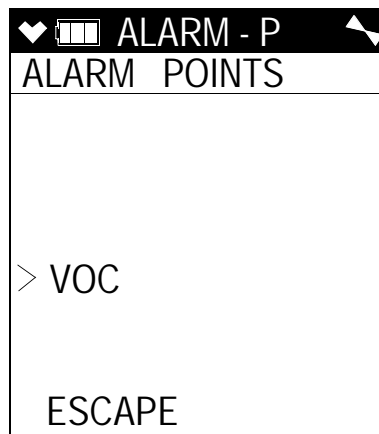

3. Press and release POWER/ENTER. The channel's alarm points are displayed.

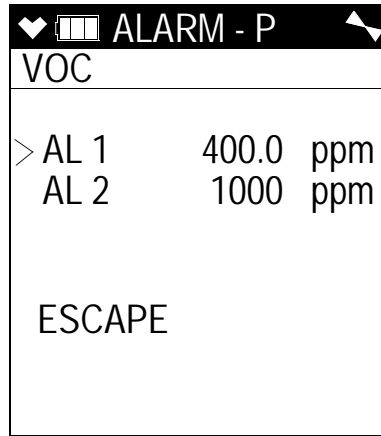

4. Move the cursor next to the alarm point that you want to update.
5. Press and release POWER/ENTER. The alarm point will begin to flash.
6. Use ▲AIR and SHIFT ▼(PANIC) to adjust the alarm point to the desired setting. Keep the following in mind:
 - Alarm 1 cannot be set higher than Alarm 2 and Alarm 2 cannot be set lower than Alarm 1.
7. If you want to continue with the change, press and release POWER/ENTER to accept the setting.

If you want to exit this screen without saving any change to the alarms, press and release DISP/LOCK to return to the Channel Select Screen.

8. When you are done making changes, use SHIFT ▼(PANIC) to move the cursor next to **ESCAPE** and press and release the POWER/ENTER button.
9. Use SHIFT ▼(PANIC) to move the cursor next to **ESCAPE**.
10. Press and release POWER/ENTER to return to the **ALARM SETTING** menu.

Updating the Alarm Latching Setting (ALARM LATCHING)

With **ALARM LATCHING** set to **LATCHING** (factory setting), the GX-6000 remains in alarm condition until the alarm condition passes *and* the RESET button is pressed.

With **ALARM LATCHING** set to **SELF RESET**, the GX-6000 automatically resets an alarm when the alarm condition passes.

1. From the **ALARM SETTING** menu, place the cursor next to **ALARM LATCHING**.
2. Press and release POWER/ENTER. The Alarm Latching Screen appears.
3. Use ▲AIR or SHIFT ▼(PANIC) to display the desired setting.
4. Press and release POWER/ENTER to save the setting and return to the **ALARM SETTING** menu.

Updating the Alarm Silence Setting (ALARM SILENCE)

With **ALARM SILENCE** set to **ON** (factory setting), pressing and releasing the RESET button silences the buzzer when the GX-6000 is in alarm. The LEDs continue to flash, the vibrator continues to pulse, and the display continues to show the alarm. If you enter Display Mode during an alarm condition, the buzzer will be silenced but the LEDs will continue to flash and the vibrator will continue to pulse. If you return to Measuring Mode

and there is still an alarm condition, the LEDs will continue to flash, the vibrator will continue to pulse, and the buzzer will remain off.

With **ALARM SILENCE** set to **OFF**, you cannot silence the buzzer. If you enter Display Mode during an alarm condition, the buzzer will not be silenced, the LEDs will continue to flash, and the vibrator will continue to pulse.

1. From the **ALARM SETTING** menu, place the cursor next to **ALARM SILENCE**.
2. Press and release **POWER/ENTER**. The Alarm Silence Option Screen appears.
3. Use **▲AIR** or **SHIFT ▼ (PANIC)** to display the desired setting.
4. Press and release **POWER/ENTER** to save the setting and return to the **ALARM SETTING** menu.

Returning to the Maintenance Mode Menu (ESCAPE)

1. From the **ALARM SETTING** screen, place the cursor next to **ESCAPE**.
2. Press and release **POWER/ENTER**. The instrument will return to the main menu.

Turning the Pump On/Off Display Screen On and Off (PUMP OFF DISP)

With **PUMP OFF DISP** set to **ON**, the Pump Off Screen appears in Display Mode and the user can turn off the pump in order to conserve battery power.

With **PUMP OFF DISP** set to **OFF** (factory setting), the Pump Off Screen does not appear in Display Mode and the user cannot turn the pump off.

1. From the main menu, place the cursor next to **PUMP OFF DISP**.
2. Press and release **POWER/ENTER**. The Pump Off Display Screen appears.
3. Use **▲AIR** or **SHIFT ▼ (PANIC)** to display the desired setting.
4. Press and release **POWER/ENTER** to save the setting and return to the main menu.

Turning the User/Station ID Function On or Off (ID DISPLAY)

With **ID DISPLAY** set to **ON**, the User ID and Station ID Screens display during start up and in Display Mode.

With **ID DISPLAY** set to **OFF** (factory setting), the User ID and Station ID Screens do not display during start up or in Display Mode.

1. From the main menu, place the cursor next to **ID DISPLAY**.
2. Press and release **POWER/ENTER**. The User and Station ID's Screen appears.
3. Use **▲AIR** or **SHIFT ▼ (PANIC)** to display the desired setting.
4. Press and release **POWER/ENTER** to save the setting and return to the main menu.

Updating the Backlight Time Setting (BACK LIGHT TIME)

This setting indicates the length of time the LCD illuminates when you press any button. The minimum setting is **OFF**; the maximum setting is 255 seconds. The factory setting is 30 seconds.

1. From the main menu, place the cursor next to **BACK LIGHT TIME**.

2. Press and release POWER/ENTER. The Back Light Time Screen appears.
3. Use ▲AIR and SHIFT ▼(PANIC) to adjust the time to the desired setting.
4. Press and release POWER/ENTER to save the setting and return to the main menu.

Updating the Language Setting (LANGUAGE)

This setting allows you to select the language for the GX-6000's user interface. The available choices are English (factory setting), Japanese, Italian, Spanish, German, French, Portuguese, Russian, and Korean.

1. From the main menu, place the cursor next to **LANGUAGE**.
2. Press and release POWER/ENTER. The Select Language Screen appears with the cursor in front of the current language.
3. Use ▲AIR or SHIFT ▼(PANIC) to move the cursor in front of the desired language.

If you do not wish to select a new language, press and release DISP/LOCK. The unit will return to the main menu.

4. Press and release POWER/ENTER to save the new language setting and return to the main menu. The GX-6000's user interface will now be in the newly selected language.
5. If you select a language other than English, a prompt will appear during startup that allows you to change the language back to English if desired.

Updating the Lunch Break Setting (LUNCH BREAK)

With **LUNCH BREAK** set to **OFF** (factory setting), the GX-6000 automatically starts new TWA and PEAK reading collection and resets the time in operation at startup.

With **LUNCH BREAK** set to **ON**, the Lunch Break Screen displays during startup. From this screen, you can choose to continue accumulating TWA and PEAK readings and the time in operation from the last time the GX-6000 was used or start collecting new readings and reset the time in operation.

1. From the main menu, place the cursor next to **LUNCH BREAK**.
2. Press and release POWER/ENTER. The Lunch Break Screen appears.
3. Use ▲AIR or SHIFT ▼(PANIC) to display the desired setting.
4. Press and release POWER/ENTER to save the setting and return to the main menu.

Updating the Auto Zero Setting (AUTO ZERO)

This setting allows you to configure the GX-6000 so that a fresh air adjustment takes place automatically as part of the instrument startup sequence. If **AUTO ZERO** is set to **ON**, the GX-6000 performs a fresh air adjustment at the end of the startup sequence before entering Measuring Mode. The factory setting is **OFF**.

WARNING: *If the automatic fresh air feature is turned on, you must startup the GX-6000 in a known fresh air environment, an environment free of toxic or combustible gases and of normal oxygen content (20.9%). If this feature is on and the GX-6000 is started up in the presence of a target gas, the reading and alarms will not be accurate or reliable.*

1. From the main menu, place the cursor next to **AUTO ZERO**.
2. Press and release **POWER/ENTER**. The Fresh Air Adjust Screen appears.
3. Use **▲AIR** or **SHIFT ▼(PANIC)** to display the desired setting.
4. Press and release **POWER/ENTER** to save the setting and return to the main menu.

Updating the Demand Zero Setting (DEMAND ZERO)

With **DEMAND ZERO** set to **ON** (factory setting), you can manually perform a fresh air adjust in Measuring Mode by pressing the **▲ AIR** button.

With **DEMAND ZERO** set to **OFF**, you cannot manually perform a fresh air adjust in Measuring Mode.

1. From the main menu, place the cursor next to **DEMAND ZERO**.
2. Press and release **POWER/ENTER**. The Demand Zero Screen appears.
3. Use **▲AIR** or **SHIFT ▼(PANIC)** to display the desired setting.
4. Press and release **POWER/ENTER** to save the setting and return to the main menu.

Zero Follower Settings (ZERO FOLLOWER)

The **ZERO FOLLOWER** setting is not intended for field adjustment. The default setting is **ON**.

Zero Suppression Settings (ZERO SUPPRESS)

The **ZERO SUPPRESS** setting is not intended for field adjustment. The PID channel's zero suppression is 0% even though a different value may be displayed.

Updating the Autoranging Setting (IR AUTO RANGE)

This menu item does not apply to this version of the GX-6000.

Updating the Confirmation Alert Setting (CONFIRMATION)

With **CONFIRMATION** set to **ON**, the GX-6000 periodically double beeps and double flashes the LED arrays to verify that it is operating. The interval between the confirmation alert can be defined once you set **CONFIRMATION** to **ON**. The interval can be 1 - 60 minutes. The factory setting is 5 minutes.

With **CONFIRMATION** set to **OFF** (factory setting), the GX-6000 does not provide a confirmation alert.

1. From the main menu, place the cursor next to **CONFIRMATION**.
2. Press and release **POWER/ENTER**. The Confirmation Alert Screen appears.
3. Use **▲AIR** or **SHIFT ▼ (PANIC)** to display the desired setting.
4. Press and release **POWER/ENTER** to save the setting. If you set **CONFIRMATION** to **OFF**, the instrument will return to the main menu.
5. If you set **CONFIRMATION** to **ON**, the interval screen will appear.

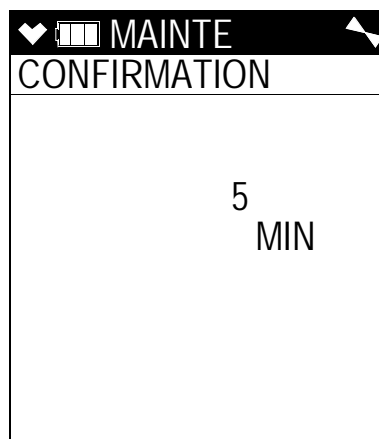

6. Use **▲AIR** or **SHIFT ▼ (PANIC)** to display the desired setting.
7. Press and release **POWER/ENTER** to save the setting and return to the main menu.

Turning the Key Tone Noise On or Off (KEY TONE)

With **KEY TONE** set to **ON** (factory setting), the instrument will beep every time a button is pressed.

With **KEY TONE** set to **OFF**, the instrument will not beep when a button is pressed.

1. From the main menu, place the cursor next to **KEY TONE**.
2. Press and release **POWER/ENTER**. The Key Tone Screen appears.
3. Use **▲AIR** or **SHIFT ▼ (PANIC)** to display the desired setting.
4. Press and release **POWER/ENTER** to save the setting and return to the main menu.

Turning Inert Mode On or Off (INERT MODE)

This menu item does not apply to this version of the GX-6000.

Updating the Leak Check/Bar Hole Mode Setting (L./B. MODE)

This menu item does not apply to this version of the GX-6000.

Setting the Bar Hole Measurement Time (BAR HOLE TIME)

This menu item does not apply to this version of the GX-6000.

Updating the CO Display Setting (CO DISPLAY)

This menu item does not apply to this version of the GX-6000.

Updating the Man Down Settings (MAN DOWN)

The **MAN DOWN** menu item in Maintenance Mode has a sub menu with 6 menu items: **MAN DOWN**, **PANIC**, **WARNING 1 TIME**, **WARNING 2 TIME**, **ALARM TIME**, and **ESCAPE**.

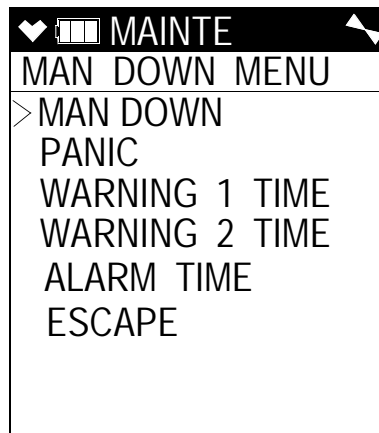

1. From the main menu, place the cursor next to **MAN DOWN**.
2. Press and release POWER/ENTER. The **MAN DOWN MENU** screen appears.

Updating the MAN DOWN Setting

With **MAN DOWN** set to **ON**, the Man Down alarm can be triggered if the instrument detects no motion for the period of time defined in **WARNING 1 TIME**, **WARNING 2 TIME**, and **ALARM TIME** below.

With **MAN DOWN** set to **OFF** (factory setting), the Man Down alarm cannot be triggered.

See “Measuring Mode, Alarms” on page 33 for a description of the Man Down alarm.

1. From the **MAN DOWN MENU** screen, place the cursor next to **MAN DOWN**.
2. Press and release POWER/ENTER. The Man Down Screen appears.
3. Use ▲AIR or SHIFT ▼ (PANIC) to display the desired setting.

4. Press and release POWER/ENTER to save the setting and return to the **MAN DOWN MENU** screen.

Updating the PANIC Setting

With **PANIC** set to **ON** (factory setting), a Panic Alarm can be manually initiated by holding down the SHIFT ▼ (PANIC) button.

With **PANIC** set to **OFF**, a Panic Alarm cannot be manually initiated.

See “Measuring Mode, Alarms” on page 33 for a description of the Panic Alarm.

1. From the **MAN DOWN MENU** screen, place the cursor next to **PANIC**.
2. Press and release POWER/ENTER. The Panic Screen appears.
3. Use ▲AIR or SHIFT ▼ (PANIC) to display the desired setting.
4. Press and release POWER/ENTER to save the setting and return to the **MAN DOWN MENU** screen.

Updating the WARNING 1 TIME Setting

The **WARNING 1 TIME** is the amount of time that has to pass between a Man Down detection and the first preliminary alarm. It can be set in 1 second increments from 10 - 120 seconds. The factory setting is 60 seconds. When setting the **WARNING 1 TIME**, keep in mind that **ALARM TIME ≥ WARNING 2 TIME ≥ WARNING 1 TIME**.

1. From the **MAN DOWN MENU** screen, place the cursor next to **WARNING 1 TIME**.
2. Press and release POWER/ENTER. The Warning 1 Time Screen appears.
3. Use ▲AIR or SHIFT ▼ (PANIC) to display the desired setting.
4. Press and release POWER/ENTER to save the setting and return to the **MAN DOWN MENU** screen.

Updating the WARNING 2 TIME Setting

The **WARNING 2 TIME** is the amount of time that has to pass between a Man Down detection and the second preliminary alarm. It can be set in 1 second increments from 10 - 120 seconds. The factory setting is 75 seconds. When setting the **WARNING 2 TIME**, keep in mind that

ALARM TIME ≥ WARNING 2 TIME ≥ WARNING 1 TIME.

1. From the **MAN DOWN MENU** screen, place the cursor next to **WARNING 2 TIME**.
2. Press and release POWER/ENTER. The Warning 2 Time Screen appears.
3. Use ▲AIR or SHIFT ▼ (PANIC) to display the desired setting.
4. Press and release POWER/ENTER to save the setting and return to the **MAN DOWN MENU** screen.

Updating the ALARM TIME Setting

The **ALARM TIME** is the amount of time that has to pass between a Man Down detection and the main alarm. It can be set in 1 second increments from 10 - 120 seconds. The factory setting is 90 seconds. When setting the **ALARM TIME**, keep in mind that **ALARM TIME ≥ WARNING 2 TIME ≥ WARNING 1 TIME**.

1. From the **MAN DOWN MENU** screen, place the cursor next to **ALARM TIME**.
2. Press and release POWER/ENTER. The Alarm Time Screen appears.

3. Use **▲AIR** or **SHIFT ▼(PANIC)** to display the desired setting.
4. Press and release **POWER/ENTER** to save the setting and return to the **MAN DOWN MENU** screen.

Returning to the Maintenance Mode Menu (ESCAPE)

1. From the **MAN DOWN MENU** screen, place the cursor next to **ESCAPE**.
2. Press and release **POWER/ENTER**. The instrument will return to the main menu.

Updating Datalogging Parameters (LOG SETTING)

The **LOG SETTING** menu item in Maintenance Mode has a sub menu with 4 menu items: **LOG INTERVAL**, **LOG CLEAR DISP**, **LOG OVER WRITE**, and **ESCAPE**.

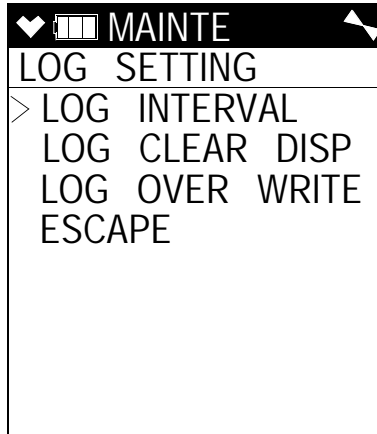

1. From the main menu, place the cursor next to **LOG SETTING**.
2. Press and release **POWER/ENTER**. The **LOG SETTING** menu appears.

Updating the Data Log Interval Setting (LOG INTERVAL)

This setting indicates how often the GX-6000 saves the gas reading to the data logger. The following interval times can be selected: 10 minutes, 5 minutes (factory setting), 3 minutes, 2 minutes, 1 minute, 30 seconds, 20 seconds, or 10 seconds.

1. From the **LOG SETTING** screen, place the cursor next to **LOG INTERVAL**.
2. Press and release **POWER/ENTER**. The Log Interval Screen appears.
3. Use **▲AIR** or **SHIFT ▼(PANIC)** to display the desired setting.
4. Press and release **POWER/ENTER** to save the setting and return to the **LOG SETTING** screen.

Updating the Log Clear Display Setting (LOG CLEAR DISP)

With **LOG CLEAR DISP** set to **ON** (factory setting), the **LOG CLEAR** Screen appears in Display Mode (see “**LOG CLEAR** Screen” on page 47).

With **LOG CLEAR DISP** set to **OFF**, the **LOG CLEAR** Screen does not appear in Display Mode.

1. From the **LOG SETTING** screen, place the cursor next to **LOG CLEAR DISP**.
2. Press and release **POWER/ENTER**. The Log Clear Display Screen appears.
3. Use **▲AIR** or **SHIFT ▼(PANIC)** to display the desired setting.
4. Press and release **POWER/ENTER** to save the setting and return to the **LOG SETTING** screen.

Updating the Data Log Overwrite Setting (LOG OVER WRITE)

With **LOG OVER WRITE** set to **ON** (factory setting), the GX-6000 writes over the oldest data with new data when the data logger memory is full.

With **LOG OVER WRITE** set to **OFF**, the GX-6000 stops saving data to the data logger when the data logger memory is full.

1. From the **LOG SETTING** screen, place the cursor next to **LOG OVER WRITE**.
2. Press and release **POWER/ENTER**. The Log Over Write Screen appears.
3. Use **▲AIR** or **SHIFT ▼ (PANIC)** to display the desired setting.
4. Press and release **POWER/ENTER** to save the setting and return to the **LOG SETTING** screen.

Returning to the Maintenance Mode Menu (ESCAPE)

1. From the **LOG SETTING** screen, place the cursor next to **ESCAPE**.
2. Press and release **POWER/ENTER**. The instrument will return to the main menu.

Adjusting the Low Flow Setpoint (FLOW ADJUST)

If your instrument repeatedly goes into low flow alarm and you have tried all of the recommendations in the Troubleshooting section, you may need to perform a low flow setpoint adjustment.

1. Use the **▲AIR** or **SHIFT ▼ (PANIC)** button to place the cursor next to **FLOW ADJUST**.
2. Press and release the **POWER/ENTER** button. The pump will turn off and the screen will display values that reflect the pump's current draw.

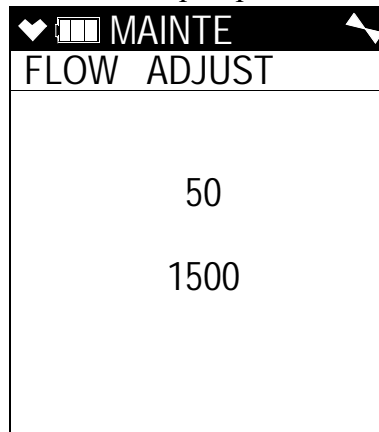

3. Use the **▲AIR** and **SHIFT ▼ (PANIC)** buttons to get a reading of approximately 1500 on the bottom value. When you have adjusted the value as close as you can, press and release the **POWER/ENTER** button.

- The pump will turn on and two new values will be displayed. The top will be a reference value and the bottom will reflect the pump's current draw.

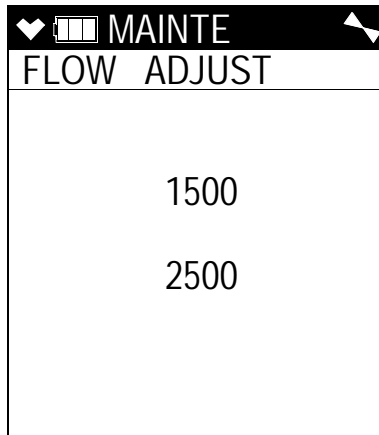

- Connect a flow meter with a valve to the inlet of the instrument and adjust it to $0.2 \text{ LPM} \pm 0.1 \text{ LPM}$. This will be the low flow setpoint. You do not need to adjust anything at the instrument.
- Press and release the POWER/ENTER button to save the changes and return to the main menu.

Viewing the ROM/SUM of the Instrument (ROM/SUM)

The **ROM/SUM** screen shows the firmware version that is loaded in the instrument and the firmware checksum.

- Use the **▲AIR** or **SHIFT ▼ (PANIC)** button to place the cursor next to **ROM/SUM**.
- Press and release the POWER/ENTER button. The ROM and checksum values for your unit will be displayed.

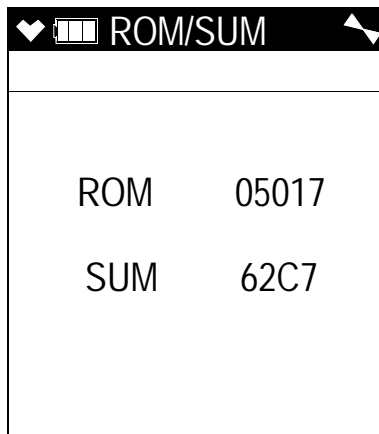

- The first line displays the ROM number. The ROM number indicates the firmware version number. In the above example, the ROM number is 05017. The bottom line displays the firmware file's checksum, 62C7 in the above example.
- Press and release the POWER/ENTER button again to return to the main menu.

Turning the Password Function On or Off (PASSWORD)

With **PASSWORD** set to **ON** (factory setting), the GX-6000 prompts you for a password when you enter Maintenance Mode. The factory set password is 0006.

With **PASSWORD** set to **OFF**, no password is required to enter Maintenance Mode.

1. From the main menu, place the cursor in front of **PASSWORD**.
2. Press and release **POWER/ENTER**. The Password Protection Screen appears.
3. Use **▲AIR** or **SHIFT ▼(PANIC)** to display the desired setting.
4. If you selected **OFF**, press and release **POWER/ENTER** to save the setting and return to the main menu.

If you selected **ON**, continue with Step 5.

5. Press and release **POWER/ENTER**. The Set Password Screen appears. 0000 is at the bottom of the screen with the first 0 flashing.

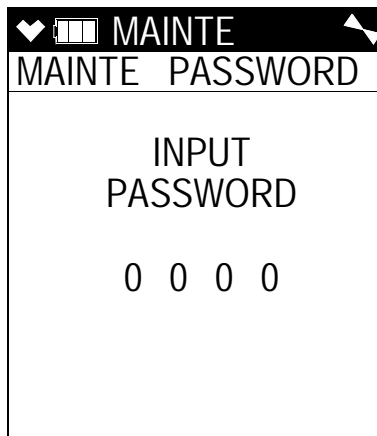

6. Use **▲AIR** or **SHIFT ▼(PANIC)** to display a number from 0 to 9.
7. Press and release **POWER/ENTER** to enter the selection and advance to the next number.
8. Repeat Step 6 and Step 7 to select the remaining numbers. When you press and release **POWER/ENTER** to enter the last number, the password is saved and you return to the main menu.

Restoring the Default Settings (RESTORE DEFAULT)

Each of the GX-6000 setup parameters, such as the auto calibration value, zero and span settings, or parameters in Maintenance Mode, has a default setting. For the items in Maintenance Mode, the default settings are the same as the standard factory settings. If you want to return the GX-6000 to its default configuration, it is possible to do so by using the Default Settings menu item in Maintenance Mode. Returning the GX-6000 to its default configuration can be useful if various setup parameters have been changed in the field and you want to return the GX-6000 to its original configuration as shipped from the factory.

There are some special GX-6000 configurations that may have a different default configuration than the standard. Consult RKI Instruments, Inc. for information regarding non-standard default configurations.

WARNING: When the GX-6000 is restored to its default configuration, the zero and span values are reset. You must recalibrate the instrument if you restore the GX-6000 to its default configuration.

1. From the main menu, place the cursor in front of **RESTORE DEFAULT**.
2. Press and release POWER/ENTER. The Restore All? Screen appears asking if you want to restore the default configuration.

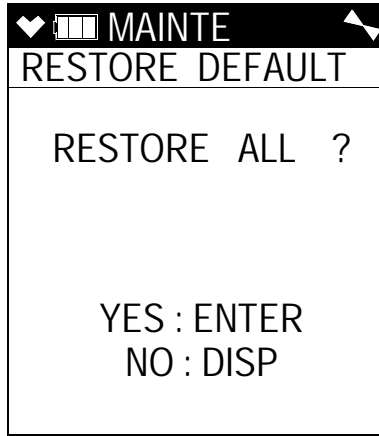

3. If you do not want to restore the default configuration, press and release DISP/LOCK to return to the main menu.

If you do want to restore the default configuration, continue with Step 4.

4. Press and release the POWER/ENTER button. A screen appears asking you to confirm that you want to restore the default configuration.

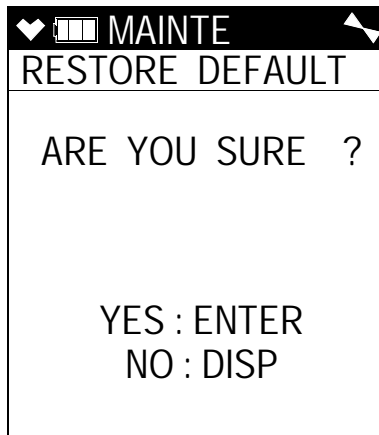

5. Press and release the POWER/ENTER button. The screen will indicate that the default configuration has been restored and return to the main menu.

Exiting Maintenance Mode (START MEASURE)

1. From the main menu, place the cursor in front of **START MEASURE** at the bottom of the menu.
2. Press and release POWER/ENTER.
3. The unit will begin its start-up sequence.

Appendix B: Maintenance Mode 2

Overview

This appendix describes the GX-6000 in Maintenance Mode 2. The GX-6000 is factory-set to suit most applications. Update settings in Maintenance Mode 2 only if required for your specific application. A description of the Maintenance Mode 2 items is shown in Table 15 below.

Table 15: Maintenance Mode 2 Menu Items

Menu Item (Page # of Description)	Description
GAS COMB (pg.141)	Turn channels on or off
HC SELECT (pg.141)	Set the catalytic LEL channel's detection gas
STREAMING MODE (pg.142)	Turn Streaming Mode on or off
START MEASURE (pg.142)	Enter Measuring Mode

Entering Maintenance Mode 2

WARNING: *The GX-6000 is not in operation as a gas detector while in Maintenance Mode 2.*

1. Take the GX-6000 to a non-hazardous location and turn it off if it is on.
2. Press and hold the ▲AIR and SHIFT ▼ (PANIC) buttons, then press and hold the POWER/ENTER button. When you hear a beep, release the buttons.
3. The screen that appears will depend on the setting of User Mode's **PASSWORD** item.

If User Mode's **PASSWORD** is set to **OFF** (factory setting), continue with Step 4.

If User Mode's **PASSWORD** is set to **ON**, continue with Step 6.

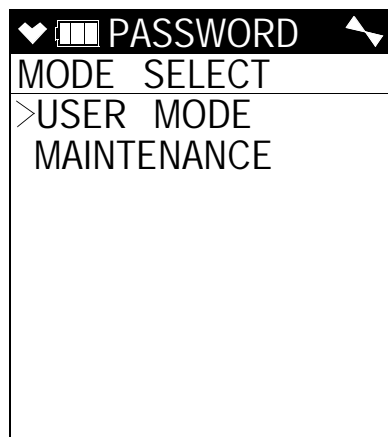

User **PASSWORD OFF**
Maint. **PASSWORD ON**
or **OFF**

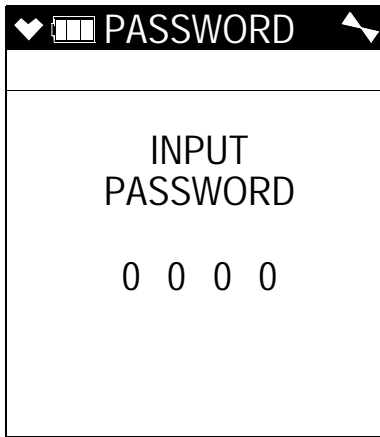

User **PASSWORD ON**
Maint. **PASSWORD ON**

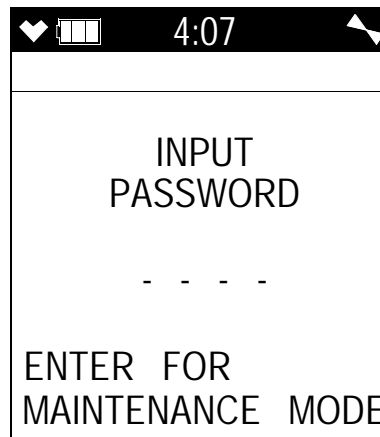

User **PASSWORD ON**
Maint. **PASSWORD OFF**

4. If User Mode's **PASSWORD** has been set to **OFF**, the Mode Select screen will appear, prompting you to choose the mode you'd like to enter.
5. Use the **▲AIR** and **SHIFT ▼(PANIC)** buttons to put the cursor in front of **MAINTENANCE** and press and release the **POWER/ENTER** button. A password screen will appear. Continue to Step 7.
6. If User Mode's **PASSWORD** has been set to **ON**, a password screen will appear.
7. The appearance of the password screen will be affected by Maintenance Mode's **PASSWORD** setting but the procedure for entering Maintenance Mode 2 is unaffected.

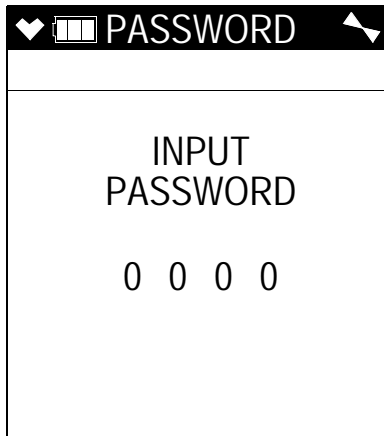

Maint. **PASSWORD** set to **ON**

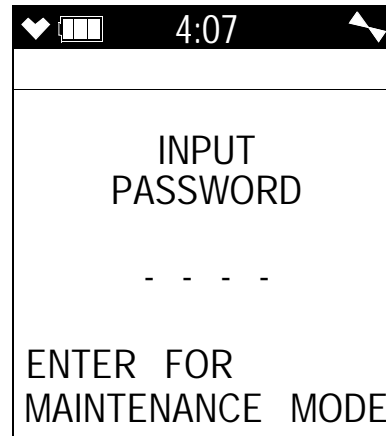

Maint. **PASSWORD** set to **OFF**

8. Enter the password for Maintenance Mode 2 by using the **▲AIR** and **SHIFT ▼(PANIC)** buttons to select each password number and then pressing and releasing the **POWER/ENTER** button to enter it and move on to the next number until all of the numbers are entered. The password for Maintenance Mode 2 is 2014.
9. If you enter an incorrect password, an error screen will appear.

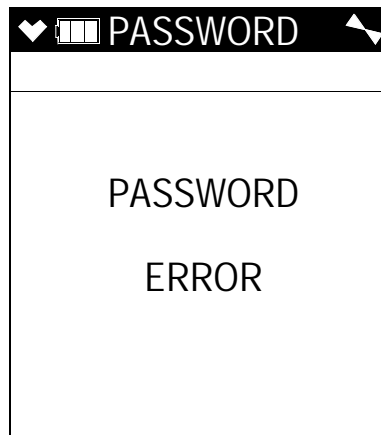

You must turn the unit off and reenter Maintenance Mode 2 using the correct password.

10 . The main menu displays.

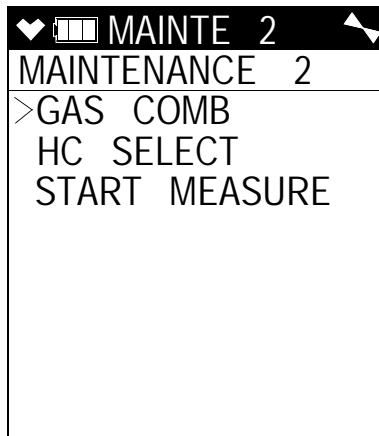

11 . Use the ▲AIR or SHIFT ▼ (PANIC) button to move the cursor up and down through the menu items.

Tips for Using Maintenance Mode 2

- When in the main menu, the cursor (>) indicates which menu item will be selected if the POWER/ENTER button is pressed and released.
- Use the SHIFT ▼ (PANIC) button to move the cursor down through the main menu and submenu items, and to lower values or change the setting in a specific option.
- Use the ▲AIR button to move the cursor up through the main menu and submenu items, and to raise values or change the setting in a specific option.
- Use the POWER/ENTER button to enter a menu item with the cursor next to it and to enter and save settings during programming.
- An adjustable parameter that is flashing can be adjusted with the ▲AIR and SHIFT ▼ (PANIC) buttons.
- Press the DISP/LOCK button while in a screen where you are entering or updating parameters to exit the screen without saving any changes. You can also use the DISP/LOCK button to back out of submenus and return to the main menu.

Changing the Gas Combination (GAS COMB)

The **GAS COMB** menu item allows you to turn channels on and off. This menu item is not used in this version of the GX-6000.

Changing the Catalytic LEL Channel's Target Gas (HC SELECT)

The **HC SELECT** menu item allows you to change the catalytic LEL channel's target gas. This menu item is not used in this version of the GX-6000.

Changing the Streaming Setting (STREAMING MODE)

With **STREAMING MODE** set to **ON**, the GX-6000 streams real-time data from the IrDA port. Contact RKI Instruments, Inc. to obtain document 71-0486 and to get more information about Streaming Mode.

With **STREAMING MODE** set to **OFF** (factory setting), the GX-6000 does not stream real-time data from the IrDA port.

- 1 . From the main menu, place the cursor next to **STREAMING MODE**.
- 2 . Press and release **POWER/ENTER**. The Streaming Mode Screen appears.
- 3 . Use **▲AIR** or **SHIFT ▼(PANIC)** to display the desired setting.
- 4 . Press and release **POWER/ENTER** to save the setting and return to the main menu.

Exiting Maintenance Mode 2 (ESCAPE)

- 1 . From the main menu, place the cursor in front of **START MEASURE** at the bottom of the menu.
- 2 . Press and release **POWER/ENTER**.
- 3 . The unit will begin its start-up sequence.

Appendix C: 10.0 eV/Benzene PID Sensor

Overview

This appendix describes the GX-6000's 10.0 eV/benzene sensor (RKI part number PID-003L).

The 10.0 eV/benzene PID sensor detects VOCs in the 0-100.00 ppm range when used in Measuring Mode. It is optimized for benzene detection. The standard calibration for the 10.0 eV/benzene PID sensor is to benzene but it can be factory setup for and calibrated to other gases. Regardless of the calibration gas, the 10.0 eV/benzene sensor will still detect and respond to a variety of volatile organic compounds (VOCs) while used in Measuring Mode. Even though the 10.0 eV/benzene sensor can be used for general VOC detection, if your application is for general VOC detection and is not related to monitoring for benzene specifically, RKI Instruments, Inc. recommends that the low range or high range 10.6 eV PID sensor be used instead.

The 10.0 eV/benzene PID sensor detects VOCs in the 0-50.00 ppm range when used in Benzene Select Mode. The filter tube that needs to be used in Benzene Select Mode allows benzene to pass through but scrubs out all other VOCs except for nitrobenzene, cyclohexane, n-octane, and n-pentane. Common applications for the 10.0 eV/benzene PID sensor include process monitoring where only benzene is present or petroleum industry monitoring where other VOCs may be present.

See the table below for 10.0 eV/benzene sensor specifications.

Table 16: 10.0 eV/Benzene PID Sensor Specifications

	Measuring Mode Operation	Benzene Select Mode Operation
Detection Range	0 - 100.00 ppm	0 - 50.00 ppm
Reading Increment	0 - 10 ppm: 0.01 ppm 10 - 100 ppm: 0.1 ppm	0 - 10 ppm: 0.01 ppm 10 - 50 ppm: 0.1 ppm
Alarm 1 Factory Setting	5 ppm	N/A
Alarm 2 Factory Setting	10 ppm	N/A
STEL Alarm	60 ppm	N/A
TWA Alarm	40 ppm	N/A

Sensor Description

The PID sensor is a cylindrical sensor with a diffusion opening on the front and 3 pins on the back. It is installed in a white housing that has three sockets on the bottom that mate with the GX-6000 instrument. The PID sensor must always be installed in the first smart sensor position which is located in the top left corner of the sensor block.

Tube and Tube Holder

Benzene detection typically requires the use of a filter tube. The filter tube will scrub out most VOCs other than benzene but will not scrub out nitrobenzene, cyclohexane, n-octane, or n-pentane. The filter tube is installed in a tube holder and needs to be replaced regularly.

A tube holder and a box of tubes are included with 10.0 eV/benzene versions of the GX-6000.

Tube

Each tube has a 3/4 line on it. If the tube becomes discolored and if the discoloration extends beyond the 3/4 line, the tube is no longer effectively scrubbing non-benzene gases and needs to be replaced.

Tubes must be stored in a cool, dark place (0 - 25 °C/ 32 - 77 °F) and must be used before the expiration date that is printed on the box. If the tubes are being stored in a refrigerator, take them out of the refrigerator and let them sit overnight before using them.

Tubes do not contain cadmium, mercury, or chrome and may be disposed as general waste.

Tube Holder

The tube holder attaches to the GX-6000's inlet fitting. It has a breakaway feature ensuring that the GX-6000 will not be damaged by hitting the tube holder on something when it is installed. The tube holder should only be used in Benzene Select Mode or when performing a calibration in TUBE CAL. If the tube holder is attached to the instrument's inlet fitting in Measuring Mode, it will cause a low flow alarm.

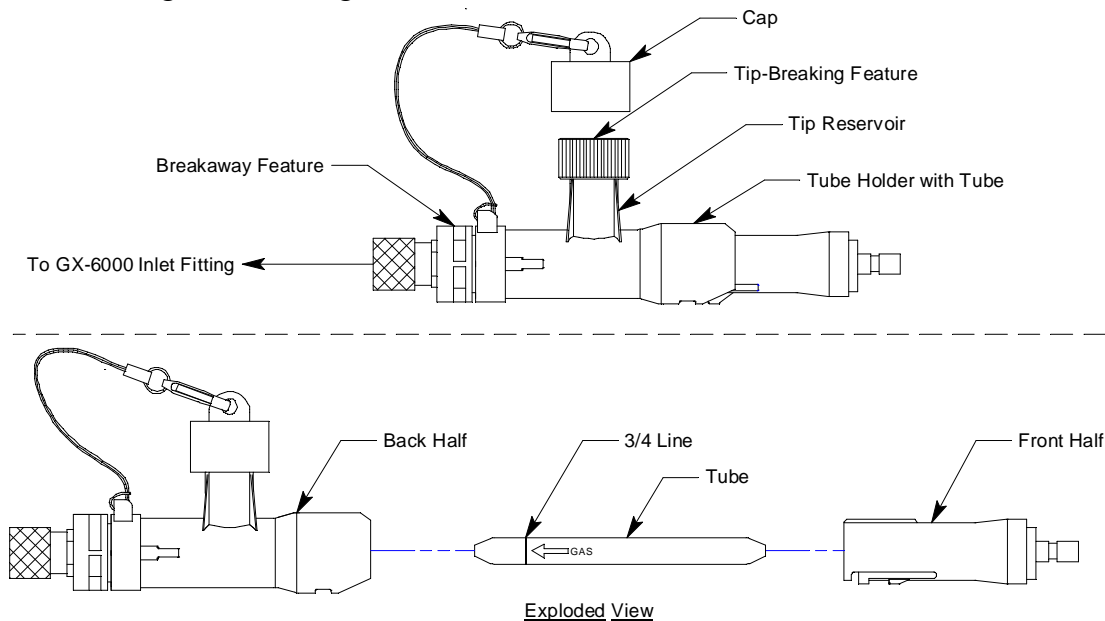
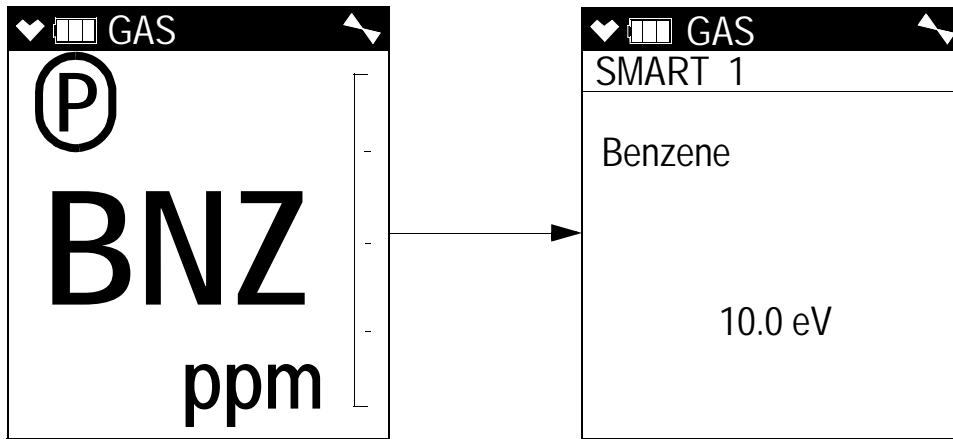

Figure 36: Tube Holder Component Location

Start Up

The instructions for starting up a GX-6000 with a 10.0 eV/benzene PID sensor installed are the same as described in “Start Up” on page 20 with the exception of the screens shown in Step 8. Those screens appear as shown below.



Display Mode

Display Mode for a 10.0 eV/benzene PID instrument appears and functions as described in “Display Mode” on page 39 with the following exceptions:

- A Benzene Select Mode screen is now the first item in Display Mode. Benzene Select Mode is described in “Benzene Select Mode” on page 146.

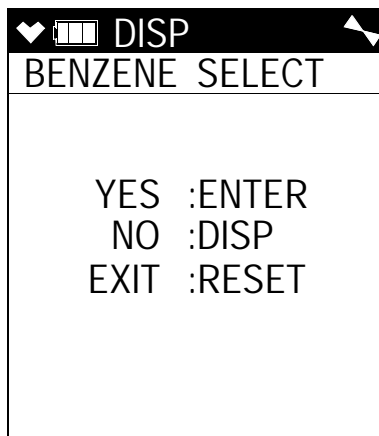

- The PID Gas Name Screen operates as described in “PID Gas Name Screen” on page 40 but is factory set up for and calibrated to benzene and appears as shown below.

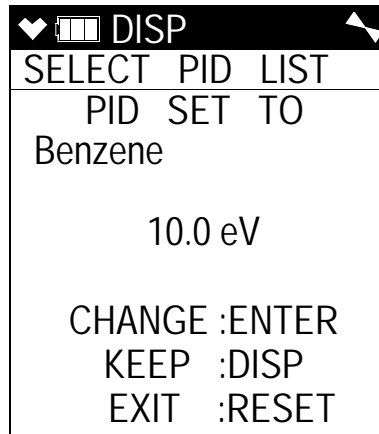

Measuring Mode

The 10.0 eV/benzene sensor detects VOCs in the 0-100.00 ppm range in Measuring Mode. See “Measuring Mode, Normal Operation” on page 29 for a complete description of Measuring Mode.

Benzene Select Mode

Benzene Select Mode allows the user to monitor for benzene in the 0-50.00 ppm range. Readings taken in Benzene Select Mode are saved to the instrument’s memory. See “Viewing Benzene Select Mode Data” on page 152 for a description of viewing data.

NOTE: A PID-003L 10.0 eV/benzene sensor must be installed in order for the Benzene Select Mode screen to appear.

A tube holder and filter tube are necessary for monitoring an area in Benzene Select Mode.

Be sure to perform an appropriate calibration for Benzene Select Mode use as described in “Important Calibration Information” on page 154 before continuing.

WARNING: *If you take the GX-6000 to an area that is 10 or 15 degrees different than the previous area, allow the instrument 45 minutes to acclimate before taking any readings. Failure to do so may cause the reading to be inaccurate.*

WARNING: *There are no alarm indications in Benzene Select Mode.*

1. Enter Display Mode by pressing the DISP/LOCK button while in Measuring Mode. The Benzene Select Mode Screen appears.

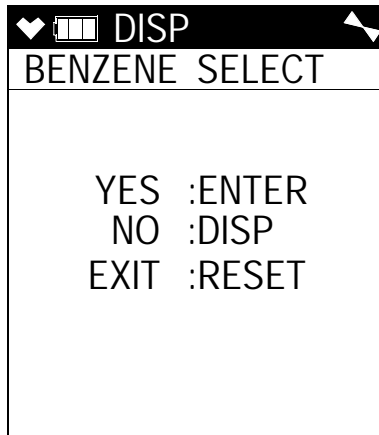

2. Press and release the POWER/ENTER button to enter Benzene Select Mode.
3. The pump will stop and the instrument will prompt you to install the filter tube and tube holder.

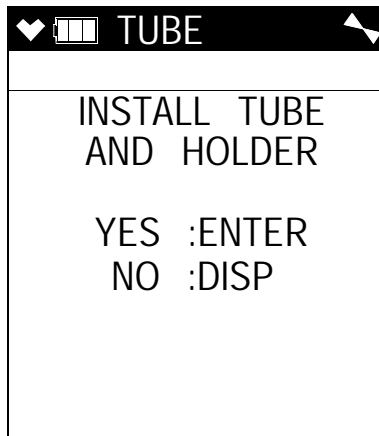

4. Be sure a filter tube is installed in the tube holder and then attach the tube holder to the instrument's inlet fitting. See "Replacing a Tube" on page 163 for instructions.
5. Press and release the POWER/ENTER button to confirm the tube and holder have been installed.
6. You will be prompted to start a benzene measurement.

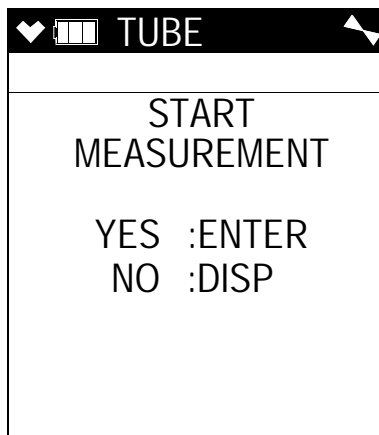

7. Press and release the POWER/ENTER button to start the benzene measurement.

- 8 . The benzene reading is displayed at the top of the screen. An automatically-determined, temperature-based countdown is displayed at the bottom of the screen. The number to the left of the countdown (“5” in the example below) is the temperature code.

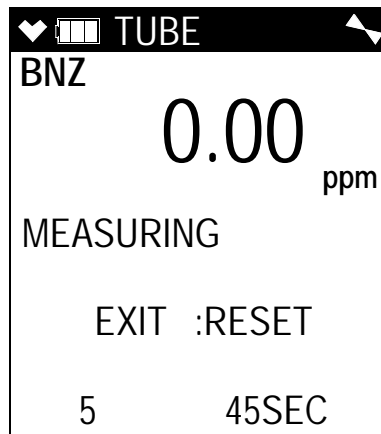

- 9 . To cancel the measurement, press and release the RESET button.

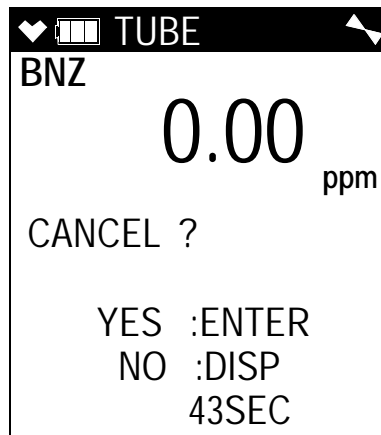

- Press the POWER/ENTER button to confirm the measurement cancel.
- Press the DISP/LOCK button to return to the measuring screen without canceling the measurement.

- 10 . Once the measurement is over, the final reading is displayed and you are asked if you want to repeat the measurement.



- To repeat a measurement, continue to Step 11.
- To not repeat a measurement and return to Measuring Mode, continue to Step 12.
- To start a STEL measurement, continue to Step 13.

- 11 . To start another measurement, press and release the POWER/ENTER button.

WARNING: *If you take the GX-6000 to an area that is 10 or 15 degrees different than the previous area, allow the instrument 45 minutes to acclimate before taking any readings. Failure to do so may cause the reading to be inaccurate.*

- a. You will be prompted to change the tube before continuing. See “Replacing a Tube” on page 163 for instructions.

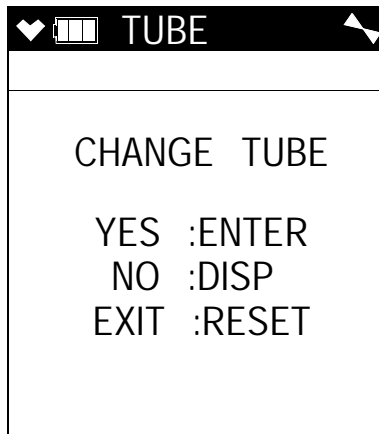

- b. Once the tube is changed, press and release the POWER/ENTER button to start the measurement. Return to Step 8.

- 12 . To not start another measurement and to return to Measuring Mode, press and release the DISP/LOCK button.
 - a. You will be prompted to remove the tube holder from the instrument's inlet fitting.

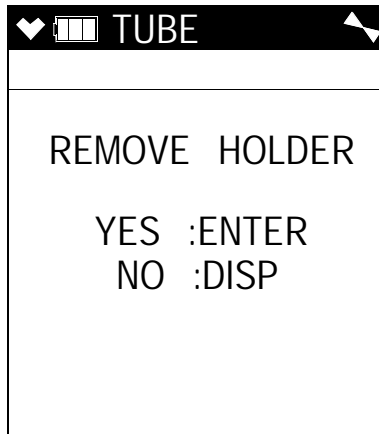

- b. Remove the tube holder from the GX-6000's inlet fitting.
 - c. Press and release the POWER/ENTER button.
- 13 . To proceed with taking a STEL measurement, press and release the RESET button.

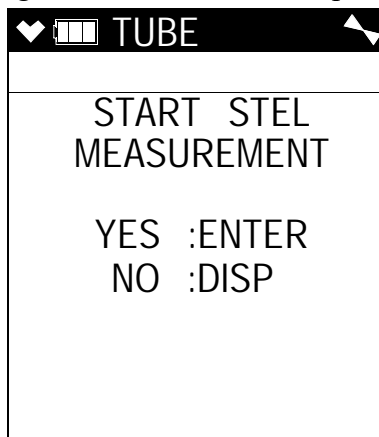

- a. Press and release the POWER/ENTER button to start a STEL measurement.
 - b. The STEL measurement takes 15 minutes and a countdown displays at the bottom of the screen. The STEL reading is displayed at the top of the screen and the instantaneous reading is displayed below it.

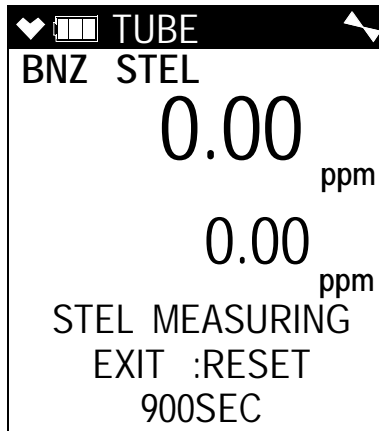

- c. To cancel the STEL measurement, press and release the RESET button. Then press and release the POWER/ENTER button.

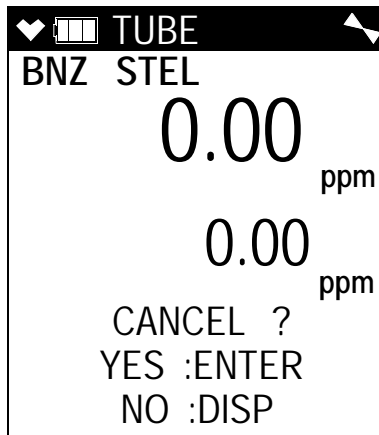

- d. At the end of the STEL countdown, the STEL reading displays.



- e. To repeat the STEL measurement, press and release POWER/ENTER.
- f. To return to Measuring Mode, press and release the DISP/LOCK button. You will be prompted to remove the tube holder from the instrument's inlet fitting.

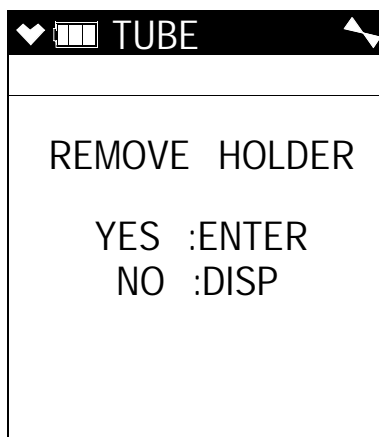

- g. Remove the tube holder from the GX-6000's inlet fitting.
- h. Press and release the POWER/ENTER button.

Viewing Benzene Select Mode Data

Readings taken in Benzene Select Mode are saved to the snap logger. To view Benzene Select Mode readings, do the following:

1. From Measuring Mode, press and release the DISP/LOCK button to enter Display Mode.
2. Continue pressing the DISP/LOCK button until the snap logging screen appears.

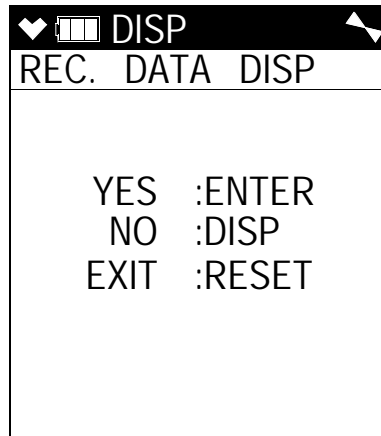

3. Press and release the POWER/ENTER button. The screen that appears will depend on whether or not any data has been saved to the snap logger.

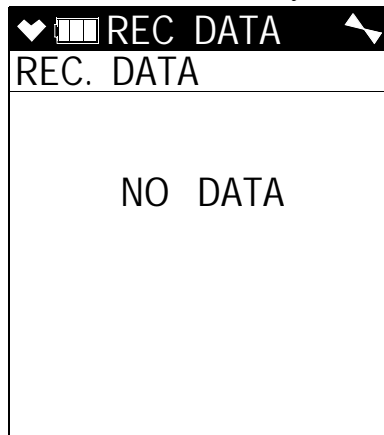

No data saved

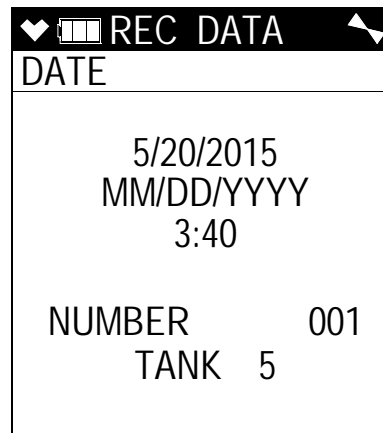

Data saved

4. If snap logs have been taken, the screen indicates the year, month, day, and time that the most recent snap log was taken.

The number near the bottom of the screen indicates the snap log ID number. The first snap log that is taken is given an ID of 001. The next snap log ID is 002. The ID number increases sequentially with each set of snap log data.

The last line of the screen indicates the Station ID that was used for the snap log.

5. Use the ▲AIR and SHIFT ▼(PANIC) buttons to scroll through different snap log IDs.

6. To view the data in a snap log ID, press and release the POWER/ENTER button.

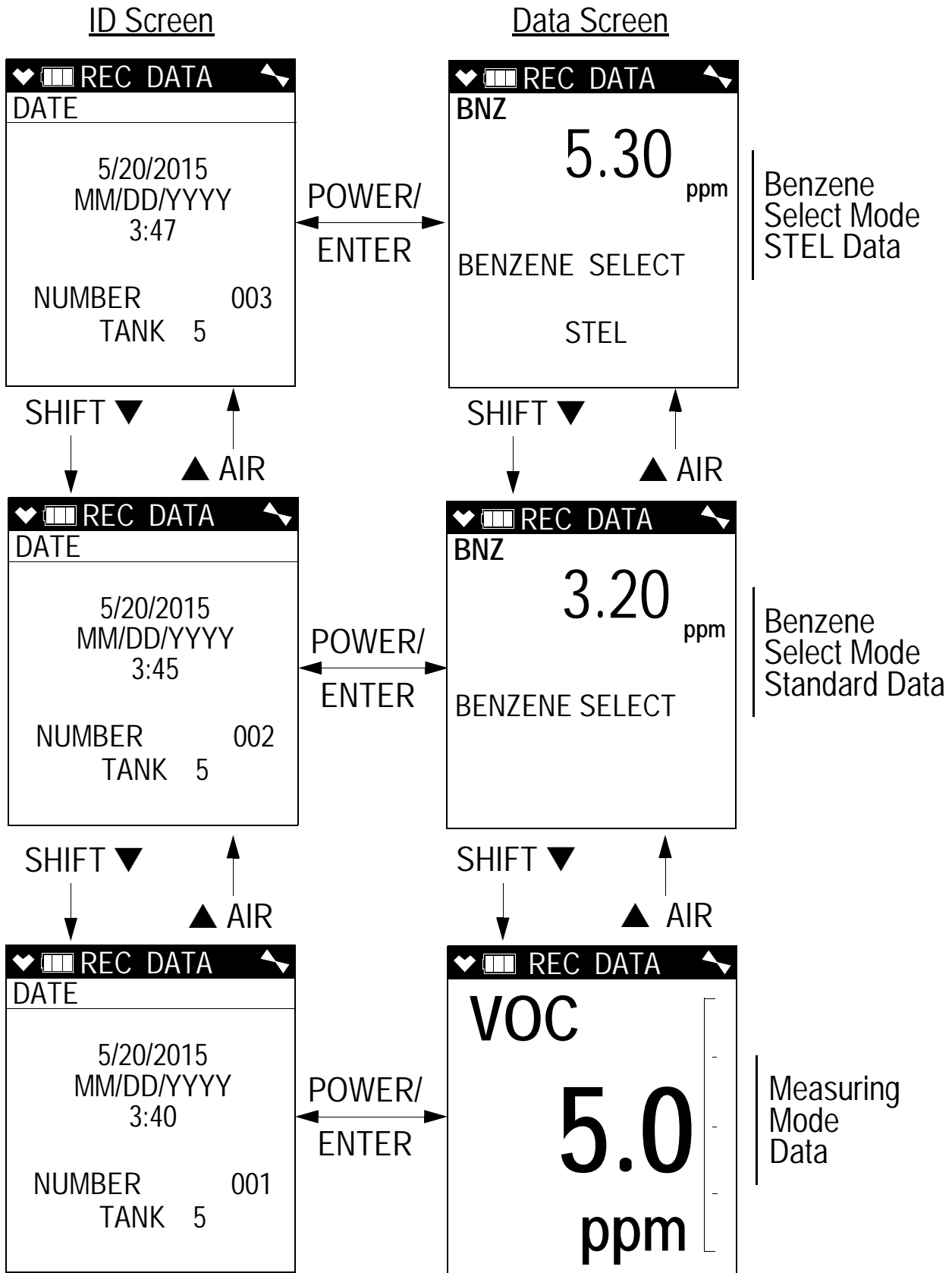

The instrument saves data from a Benzene Select Mode standard measurement and from a Benzene Select Mode STEL measurement (if performed). Data from a Benzene Select Mode standard measurement will say “BENZENE SELECT” below the reading. Data from a Benzene Select Mode STEL measurement will say “BENZENE SELECT” and “STEL” below the reading. They are separate files. Data may also be present from snap log data saved in Measuring Mode.

7. Use the ▲AIR and SHIFT ▼(PANIC) buttons to scroll through the different snap log data screens. The gas readings will change but the snap log ID is not visible from this screen.
8. You can also go back and forth between the ID and data screens by pressing and releasing the POWER/ENTER button.
9. To return to the Snap Logging Screen, press and release the DISP/LOCK button.
10. To return to Measuring Mode, press and release the RESET button.

Calibrating the 10.0 eV/Benzene PID Sensor

Important Calibration Information

Calibration of the 10.0 eV/benzene PID sensor depends on your application and on the calibration gas you have available. The most accurate way to calibrate the sensor is to use benzene gas. If it is not practical or possible to use benzene gas, another gas, such as isobutylene, can be used as long as the calibration code indicated on the box of filter tubes is entered into the instrument.

If you start using a new box of filter tubes, you may need to recalibrate. See Step 7 on page 165 for further description.

See the table below for a summary of the calibration options and requirements.

Application	Calibration Options	
Benzene Select Mode benzene detection	Option 1	1. AUTO CAL or SINGLE CAL with benzene, without tube and holder 2. TUBE CAL with benzene, with tube and holder
	Option 2	1. AUTO CAL or SINGLE CAL with isobutylene (or other target gas)** 2. enter CAL CODE
Measuring Mode, benzene detection	AUTO CAL with benzene (no TUBE CAL or CAL CODE required)	
Measuring Mode, general VOC detection*	Option 1	AUTO CAL or SINGLE CAL with benzene
	Option 2	AUTO CAL or SINGLE CAL with isobutylene (or other target gas)**
<p>* Even though it is possible to use the 10.0 eV/benzene PID sensor for general VOC detection, RKI Instruments, Inc. recommends using the low range or high range 10.6 eV sensor instead.</p> <p>** In order to calibrate to a gas other than benzene or isobutylene, you must select that other gas for the 10.0 eV/benzene sensor in the PID Gas Name Screen in Display Mode as described in “PID Gas Name Screen” on page 40. You must also select the appropriate calibration gas during the calibration procedure.</p>		

Setting the Fresh Air Reading

See “Setting the Fresh Air Reading” on page 59 for instructions to set the fresh air reading.

Performing an AUTO CAL

See “Calibrating Using the Auto Calibration Method” on page 59 for instructions to perform an automatic calibration.

Be sure that you are doing a complete calibration as appropriate for your application and for the calibration gas you have available (see “Important Calibration Information” on page 154).

Performing a SINGLE CAL

See “Calibrating Using the Single Calibration Method” on page 67 for instructions to perform a single calibration.

Be sure that you are doing a complete calibration as appropriate for your application and for the calibration gas you have available (see “Important Calibration Information” on page 154).

Performing a TUBE CAL

NOTE: A PID-003L 10.0 eV/benzene sensor must be installed in order for the TUBE CAL menu item to appear in Calibration Mode.

NOTE: If you begin to use filter tubes from a new box and if the calibration code shown on the new box is different than the calibration code shown on the old box, you must perform a TUBE CAL operation using one of the tubes from the new box.

WARNING: *If you take the GX-6000 to an area that is 10 or 15 degrees different than the previous area, allow the instrument 45 minutes to acclimate before taking any readings. Failure to do so may cause the calibration to be inaccurate.*

To calibrate the 10.0 eV/benzene sensor in TUBE CAL, you will need:

- A benzene calibration cylinder. RKI Instruments, Inc. recommends a concentration of 5 ppm.
- A demand-flow regulator to provide adequate sample gas flow.
- Non-absorbent tubing.
- Tube holder and filter tube.

Be sure that you are doing a complete calibration as appropriate for your application and for the calibration gas you have available (see “Important Calibration Information” on page 154).

Automatic TUBE CAL

1. To enter Calibration Mode, while in Measuring Mode, press and hold the SHIFT ▼ (PANIC) button, then press the DISP/LOCK button and release both buttons.

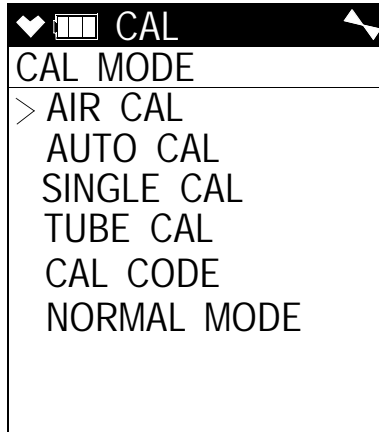

2. Use the SHIFT ▼ (PANIC) button to scroll to **TUBE CAL** and then press and release the POWER/ENTER button.
3. The pump will stop and the instrument will prompt you to install the filter tube and tube holder.

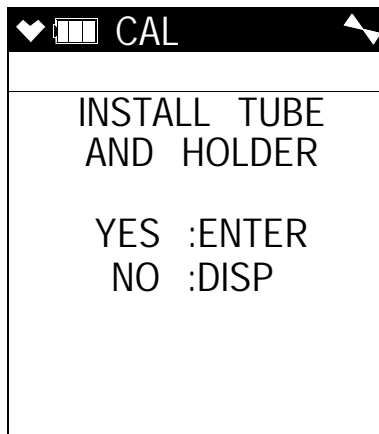

4. Be sure a filter tube is installed in the tube holder and then attach the tube holder to the instrument's inlet fitting. See "Replacing a Tube" on page 163 for instructions.
5. Press and release the POWER/ENTER button to enter the TUBE CAL Menu.

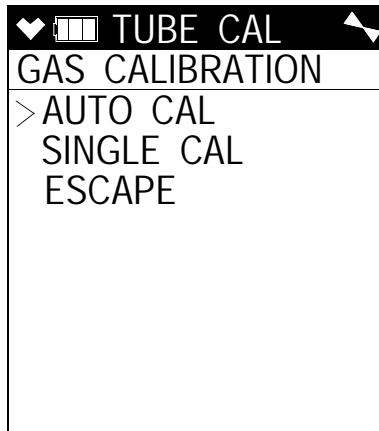

6. Use the SHIFT ▼ (PANIC) button to place the cursor next to **AUTO CAL**.

7. Press and release the POWER/ENTER button to enter the TUBE CAL Auto Calibration Menu.

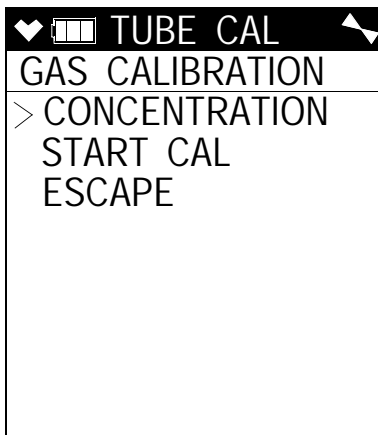

8. To view or change the benzene concentration to be used for the TUBE CAL:
 - a. Use the SHIFT ▼ (PANIC) button to place the cursor next to **CONCENTRATION**.
 - b. Press and release the POWER/ENTER button. The current concentration will be shown and it will be flashing.

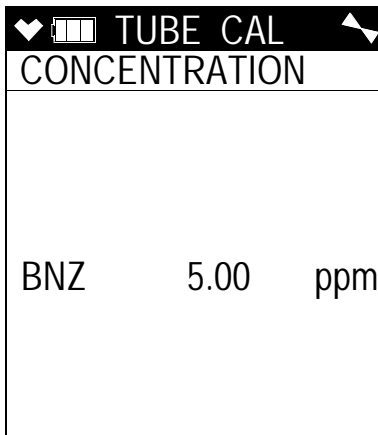

- c. Use ▲AIR or SHIFT ▼ (PANIC) to adjust the concentration.
 - d. Press and release the POWER/ENTER button to save it.
9. Screw the demand flow regulator onto the benzene calibration cylinder.
10. Attach the calibration tubing to the demand flow regulator.
11. Attach the other end of the calibration tubing to the tube holder's inlet fitting.
12. Use the SHIFT ▼ (PANIC) button to place the cursor next to **START CAL**.

- 13 . Press and release the POWER/ENTER button to start a calibration. An automatically-determined, temperature-based countdown is displayed at the bottom of the screen. The number to the left of the countdown (“5” in the example below) is the temperature code.



- 14 . If the calibration passes, the screen will indicate PASS and will return you to the TUBE CAL Auto Calibration Menu.
- 15 . If the calibration fails, a failure screen will appear and the instrument will go into alarm.

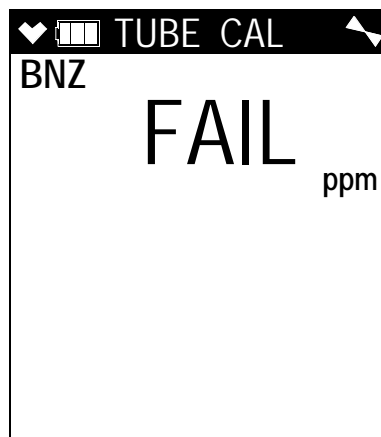

Press and release the RESET button to clear the alarm and return to the TUBE CAL Auto Calibration Menu. See “Troubleshooting” on page 83.

- 16 . Use the SHIFT ▼ (PANIC) button to place the cursor next to **ESCAPE**, then press and release the POWER/ENTER button to return to the TUBE CAL Menu.

- 17 . Use the SHIFT ▼ (PANIC) button to place the cursor next to **ESCAPE**, then press and release the POWER/ENTER button. You will be prompted to remove the filter tube and tube holder.

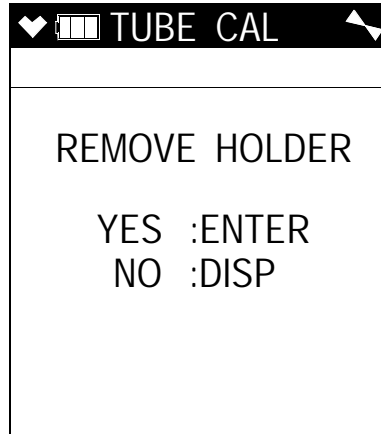

- 18 . Remove the tube holder from the GX-6000's inlet fitting.
- 19 . Press and release the POWER/ENTER button. You will return to the Calibration Mode Menu.
- 20 . Use the SHIFT ▼ (PANIC) button to place the cursor next to the **NORMAL MODE** menu option, then press and release the POWER/ENTER button to return to Measuring Mode.
- 21 . Detach the calibration tubing from the tube holder's inlet fitting.
- 22 . Unscrew the demand flow regulator from the calibration cylinder.

Single TUBE CAL

- 1 . To enter Calibration Mode, while in Measuring Mode, press and hold the SHIFT ▼ (PANIC) button, then press the DISP/LOCK button and release both buttons.

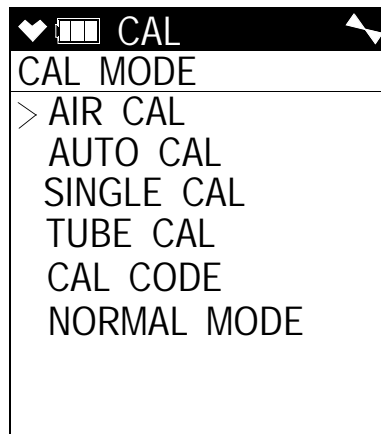

- 2 . Use the SHIFT ▼ (PANIC) button to place the cursor next to **TUBE CAL** and then press and release the POWER/ENTER button.

3. The pump will stop and the instrument will prompt you to install the filter tube and tube holder.

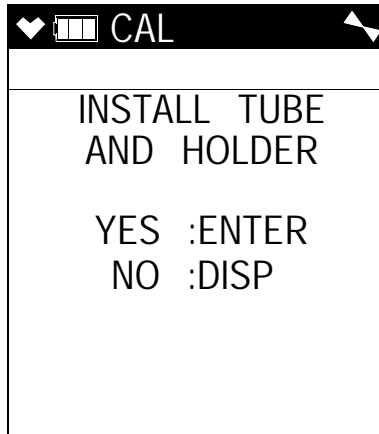

4. Be sure a filter tube is installed in the tube holder and then attach the tube holder to the instrument's inlet fitting. See "Replacing a Tube" on page 163 for instructions.
5. Press and release the POWER/ENTER button to enter the TUBE CAL Menu.

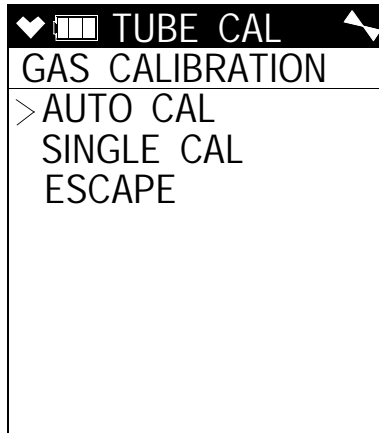

6. Screw the demand flow regulator onto the benzene calibration cylinder.
7. Attach the calibration tubing to the demand flow regulator.
8. Attach the other end of the calibration tubing to the tube holder's inlet fitting.
9. Use the SHIFT ▼ (PANIC) button to place the cursor next to **SINGLE CAL**.
10. Press and release the POWER/ENTER button.

- 11 . An automatically-determined, temperature-based countdown is displayed at the bottom of the screen. The number to the left of the countdown (“5” in the example below) is the temperature code.

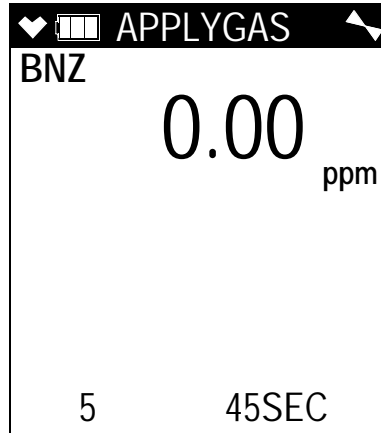

- 12 . At the end of the countdown, use the ▲AIR or SHIFT ▼ (PANIC) button to adjust the reading to match the concentration listed on the calibration cylinder.
- 13 . Press and release the POWER/ENTER button.
- 14 . If the calibration passes, the screen will indicate PASS and will return you to the TUBE CAL Menu.
If the reading cannot be adjusted to match the cylinder concentration, see “Troubleshooting” on page 83.
- 15 . Use the SHIFT ▼ (PANIC) button to place the cursor next to **ESCAPE**, then press and release the POWER/ENTER button. You will be prompted to remove the filter tube and tube holder.

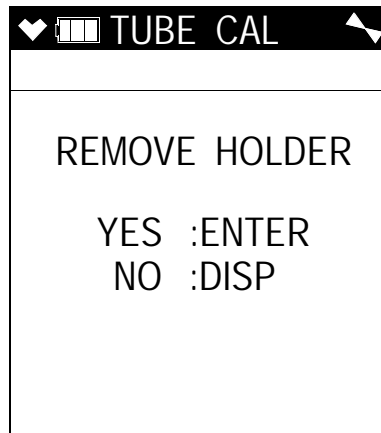

- 16 . Remove the tube holder from the GX-6000’s inlet fitting.
- 17 . Press and release the POWER/ENTER button. You will return to the Calibration Mode Menu.
- 18 . Use the SHIFT ▼ (PANIC) button to place the cursor next to the **NORMAL MODE** menu option, then press and release the POWER/ENTER button to return to Measuring Mode.
- 19 . Detach the calibration tubing from the tube holder’s inlet fitting.
- 20 . Unscrew the demand flow regulator from the calibration cylinder.

Entering a CAL CODE

NOTE: A PID-003L 10.0 eV/benzene sensor must be installed in order for the CAL CODE menu item to appear in Calibration Mode.

NOTE: If you begin to use filter tubes from a new box and if the calibration code shown on the new box is different than the calibration code shown on the old box, you must enter the new calibration code before using the new filter tubes.

An alternative to performing a TUBE CAL using a benzene calibration cylinder is to enter the calibration code found on the filter tube box. The cal code adjusts the instrument's reading in Benzene Select Mode to account for the effect that the filter tube has on the PID sensor's response to benzene. It is listed on the tube box's label and is a letter between A and J.

If you go through the CAL CODE procedure, there is no need to perform a TUBE CAL using a benzene calibration cylinder.

Be sure that you are doing a complete calibration as appropriate for your application and for the calibration gas you have available (see "Important Calibration Information" on page 154).

1. To enter Calibration Mode, press and hold the SHIFT ▼ (PANIC) button, then press the DISP/LOCK button and release both buttons.

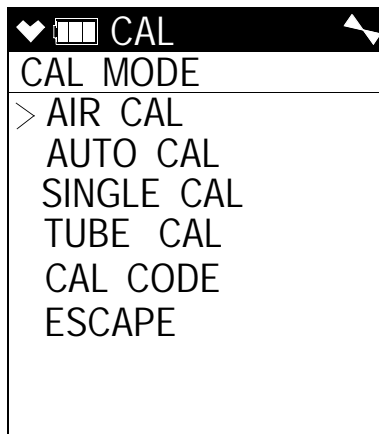

2. Use the SHIFT ▼ (PANIC) button to place the cursor next to **CAL CODE**.
3. Press and release the POWER/ENTER button.

- The current calibration code will be displayed and it will be flashing.

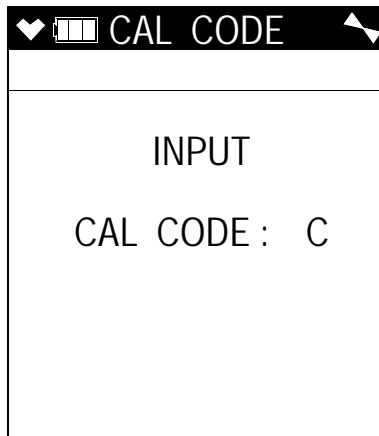

- Use ▲AIR or SHIFT ▼(PANIC) to adjust the calibration code to match the one listed on your filter tube box's label.
- Press and release the POWER/ENTER button to confirm the calibration code. The screen will show "END" and will return to the Calibration Mode menu.
- Use the SHIFT ▼(PANIC) button to place the cursor next to the **NORMAL MODE** menu option, then press and release the POWER/ENTER button to return to Measuring Mode.

Maintenance

Replacing a Sensor

See "Replacing the PID Sensor" on page 94 for sensor replacement instructions.

PID Sensor Maintenance

See "PID Sensor Maintenance" on page 98 for PID sensor maintenance instructions keeping in mind the following differences in spare parts.

Part Number	Description
33-0563	PID sensor electrode stack, 10.0 eV/benzene sensor
51-1503	PID sensor replacement lamp, 10.0 eV/benzene sensor
PID-003L	PID sensor, 10.0 eV/benzene

CAUTION: *The aluminum oxide cleaning kit described on pg.98 is only for use with the 10.0 eV and 10.6 eV PID sensors' lamps. DO NOT USE THE ALUMINUM OXIDE CLEANING KIT TO CLEAN THE 11.7 eV PID SENSOR'S LAMP!*

Replacing a Tube

When to Replace Tube

RKI Instruments, Inc. recommends that the tube be replaced before starting a new measurement in Benzene Select Mode. If discoloration of the filter material extends beyond the "3/4" line (into the side without the text and arrow), the tube needs to be replaced. Even though discoloration can be a measure of when to replace the tube, not all gases cause the filter material to discolor which is why RKI Instruments, Inc. recommends

that the tube be replaced before starting a new measurement in Benzene Select Mode.

If the tubes are being stored in a refrigerator, take them out of the refrigerator and let them sit overnight before using them.

Instructions to Replace Tube

1. Remove the front of the tube holder by pushing on the locking mechanism and pulling the front half away from the back half, shown below.

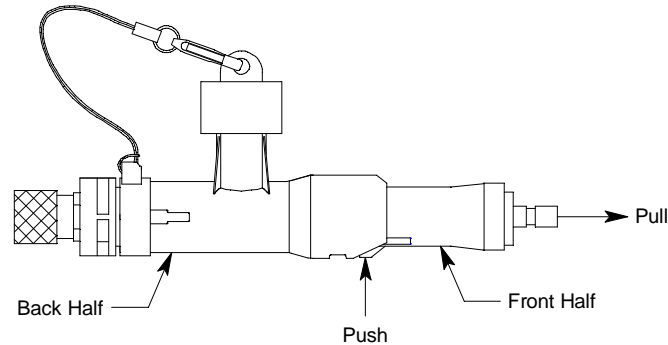

Figure 37: Replacing a Tube

2. Remove the used tube. Take care not to touch the broken ends of the tube.
3. Remove the cap from the tube holder.
4. Break off the tips of the new tube using the tube holder's tip-breaking feature. The reservoir can hold approximately 12 tips and will need to be periodically emptied.
5. Insert the new tube in the front half of the tube holder. The arrow on the tube should be pointing away from the front half.

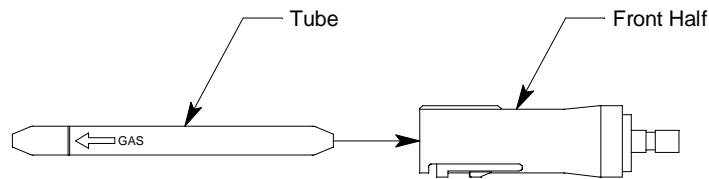

Figure 38: Inserting New Tube Into Front Half

6. Line up the locking feature in the front half with its mate in the back half and insert the front half/tube assembly into the back half making sure the locking feature engages.

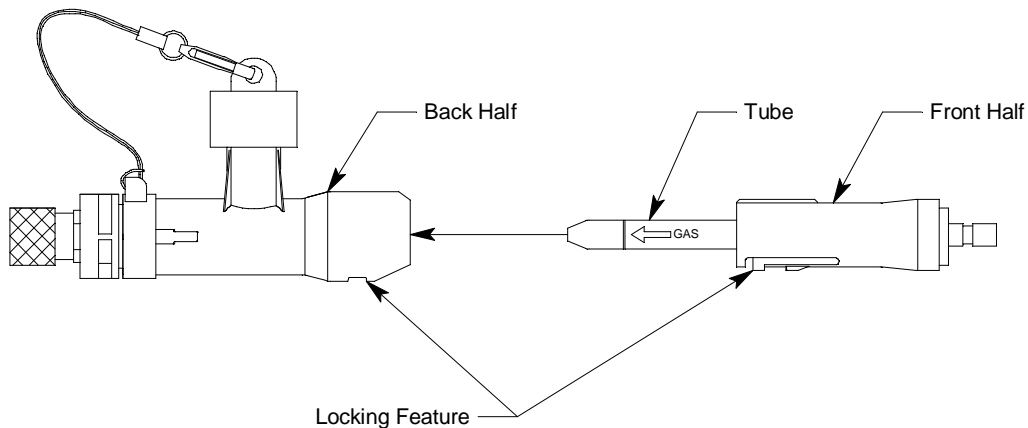

Figure 39: Reassembling Tube Holder

7. If you are replacing your old tube with a tube from a new box, compare the calibration code listed on the old box to the calibration code listed on the new box.
 - a. If the calibration codes match, there is no need to do anything else.
 - b. If the calibration codes do not match, you must either perform a TUBE CAL using a tube from the new box (see “Performing a TUBE CAL” on page 155) or you must enter the new calibration code into CAL CODE (see “Entering a CAL CODE” on page 162), depending on what method of calibration you used with your old box of filter tubes. See “Calibrating the 10.0 eV/Benzene PID Sensor” on page 154 for a description of calibration methods.
8. Tubes do not contain cadmium, mercury, or chrome and may be disposed as general waste.

Parts List for 10.0 eV/Benzene PID Instruments

The table below lists spare parts for a 10.0 eV /benzene PID instrument.

Table 17: Spare Parts List for 10.0 eV/Benzene PID Instruments

Part Number	Description
13-0550	Lanyard for tube holder (for new style tube holder with knurled tip-breaker)
13-0700	Knurled tip-breaker on tube holder (for new style tube holder with knurled tip-breaker)
13-0701	Black cap for knurled tip-breaker on tube holder (for new style tube holder with knurled tip-breaker)
33-0563	PID sensor electrode stack, 10.0 eV/benzene sensor
33-7128	Filter tubes, 1 box, 10 tubes per box
33-7128-05	Filter tubes, 5 boxes, 10 tubes per box
51-1503	PID sensor replacement lamp, 10.0 eV/benzene sensor
80-0174	Tube holder
81-0100RK-03	Calibration cylinder, benzene, 5 ppm in air, 103 liter
81-0100RK-04	Calibration cylinder, benzene, 5 ppm in air, 34 liter aluminum
81-0104RK-03	Calibration cylinder, isobutylene, 10 ppm in air, 103 liter
81-0104RK-04	Calibration cylinder, isobutylene, 10 ppm in air, 34 liter aluminum
81-6XAX-DLV	Calibration kit: 34 liter 10 ppm IBL in air cylinder, demand flow regulator, calibration tubing
81-6XZX	Calibration kit: 103 liter 5 ppm benzene in air cylinder, demand flow regulator, calibration tubing
81-6XZX-DLV	Calibration kit: 34 liter 5 ppm benzene in air cylinder, demand flow regulator, calibration tubing
82-0300RK	Aluminum oxide powder PID lamp cleaning kit, with electrode stack removal tool, for 10.0 eV and 10.6 eV PID sensors' lamps ONLY
PID-003L	PID sensor, 10.0 eV/benzene

Appendix D: 11.7 eV PID Sensor

Overview

This appendix describes the GX-6000's 11.7 eV PID sensor (RKI part number PID-004).

The 11.7 eV PID sensor detects VOCs in the 0-1000 ppm range. The standard calibration for the 11.7 eV PID sensor is to isobutylene but it can be factory setup for and calibrated to other gases. Regardless of the calibration gas, the 11.7 eV PID sensor will still detect and respond to a variety of volatile organic compounds (VOCs) while used in Measuring Mode.

The 11.7 eV PID sensor is capable of detecting VOCs that the 10.6 eV low range and high range PID sensors are not, such as:

- acrylonitrile
- carbon tetrachloride
- chloroform
- methanol
- refrigerants (R-32A, R-143)

See the table below for 11.7 eV PID sensor specifications.

Table 18: 11.7 eV PID Sensor Specifications

Detection Range	0 - 1000 ppm
Reading Increment	0 - 100 ppm: 0.1 ppm 100 - 1000 ppm: 1 ppm
Alarm 1 Factory Setting	400 ppm
Alarm 2 Factory Setting	1000 ppm
STEL Alarm	60.0
TWA Alarm	40.0

11.7 eV PID Lamp Warranty

The PID-004 11.7 eV PID sensor's lamp (RKI P/N 51-1504) is susceptible to humidity and its service life is not as long as lamps in other PID sensors sold by RKI Instruments, Inc. For this reason, the PID-004 11.7 eV sensor's lamp is warranted for 2 months from the date of shipment.

Description

Instrument

A GX-6000 that contains an 11.7 eV PID sensor is shipped with a black rubber cap plugging the inlet fitting. This rubber cap helps prolong the life of the 11.7 eV PID sensor by preventing ambient moisture from entering the flow system. This rubber cap should be installed back onto the inlet fitting before storing the GX-6000. See “Turning Off a GX-6000 with an 11.7 eV PID Sensor” on page 169 for complete storage recommendations.

Sensor

The PID sensor is a cylindrical sensor with a diffusion opening on the front and 3 pins on the back. It is installed in a white housing that has three sockets on the bottom that mate with the GX-6000 instrument. The PID sensor must always be installed in the first smart sensor position which is located in the top left corner of the sensor block.

The 11.7 eV PID sensor’s lamp is susceptible to humidity. “Turning Off a GX-6000 with an 11.7 eV PID Sensor” on page 169 outlines RKI Instruments, Inc.’s recommendations for prolonging the life of the sensor’s lamp.

Dehumidifier Filter

Every GX-6000 that contains an 11.7 eV PID sensor is shipped with a calcium chloride dehumidifier filter. The dehumidifier filter is shipped with clear tubing connecting both ends together to preserve the life of the filter. Remove the tubing from one end of the filter and draw through the filter before turning off the GX-6000 in order to purge any moisture from the flow system.

The filter should be replaced when it appears wet.

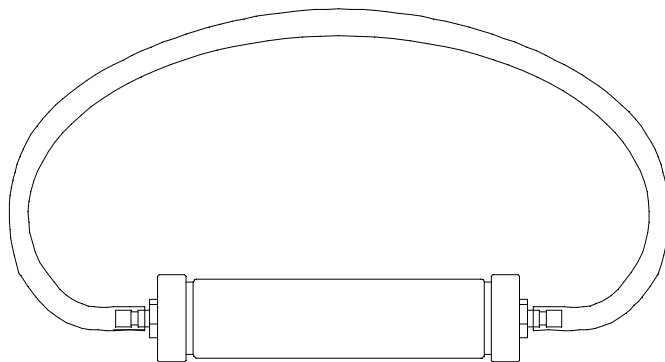

Start Up

The instructions for starting up a GX-6000 with a 11.7 eV PID sensor installed are the same as described in “Start Up” on page 20 with the following exceptions:

- Remove the black cap from the inlet fitting before turning on the instrument.
- The screens shown in Step 8 appear as shown below.

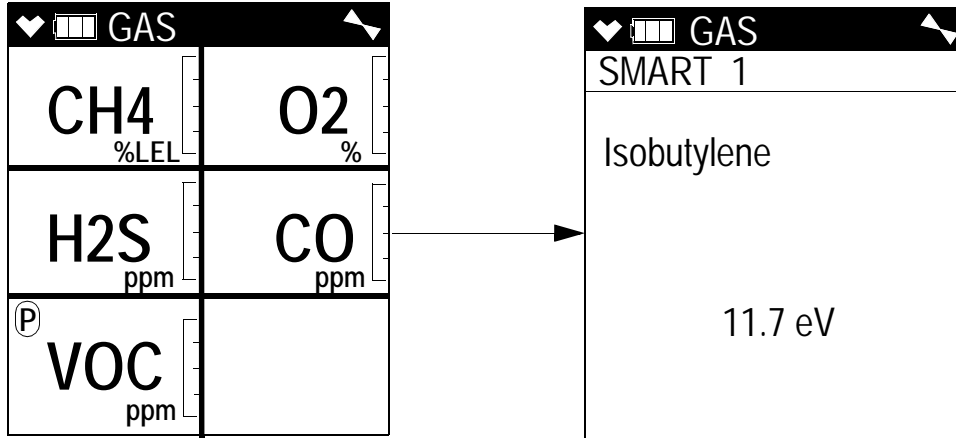

Display Mode

Display Mode for a 11.7 eV PID instrument appears and functions as described in “Display Mode” on page 39 with the following exception:

- The PID Gas Name Screen operates as described in “PID Gas Name Screen” on page 40 but appears as shown below.

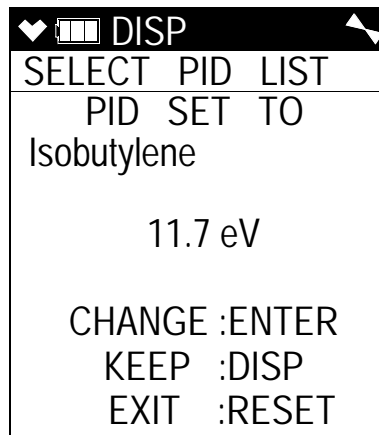

Measuring Mode

The 11.7 eV PID sensor detects VOCs in the 0-1000 ppm range. In the 0-100 ppm range, the reading increment is 0.1 ppm. In the 100-1000 ppm range, the reading increment is 1 ppm. See “Measuring Mode, Normal Operation” on page 29 for a complete description of Measuring Mode.

Turning Off a GX-6000 with an 11.7 eV PID Sensor

Eliminating as much moisture from the flow system as possible before turning off the GX-6000 will help prolong the life of the 11.7 eV PID sensor’s lamp.

1. Remove the tubing from one end of the dehumidifier filter. It does not matter which end you remove. The dehumidifier filter does not have a flow direction. Do not use the dehumidifier filter if it appears wet.
2. Connect the tubing to the GX-6000’s inlet.

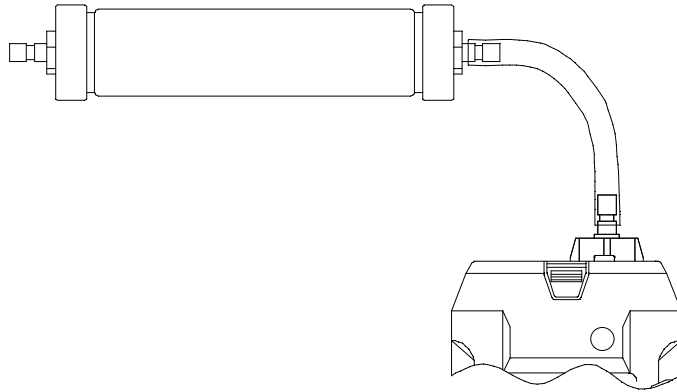

3. Allow the GX-6000 to draw through the filter for 30 seconds.
4. Turn off the GX-6000.
5. Remove the tubing from the inlet fitting and immediately plug the inlet fitting with the black rubber cap.

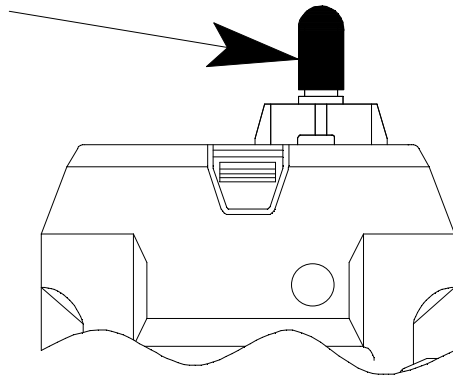

6. Reconnect the tubing to the open end of the dehumidifier filter to help preserve its life. If the filter begins to appear wet, it needs to be replaced.

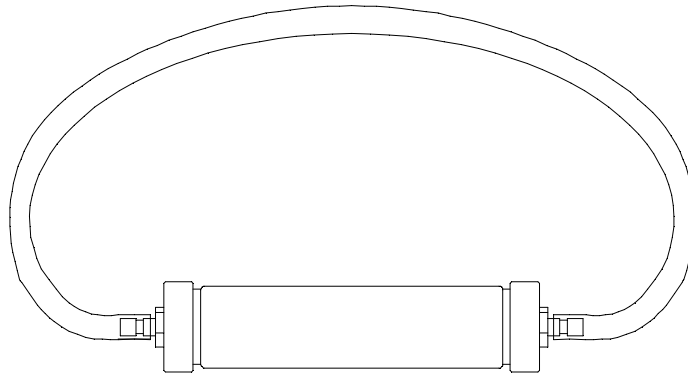

Calibrating the 11.7 eV PID Sensor

Setting the Fresh Air Reading

See “Setting the Fresh Air Reading” on page 59 for instructions to set the fresh air reading.

Performing an AUTO CAL

See “Calibrating Using the Auto Calibration Method” on page 59 for instructions to perform an automatic calibration while keeping the following in mind:

- When turning off the GX-6000 after performing a calibration, follow the instructions in “Turning Off a GX-6000 with an 11.7 eV PID Sensor” on page 169.

Performing a SINGLE CAL

See “Calibrating Using the Single Calibration Method” on page 67 for instructions to perform a single calibration while keeping the following in mind:

- When turning off the GX-6000 after performing a calibration, follow the instructions in “Turning Off a GX-6000 with an 11.7 eV PID Sensor” on page 169.

Maintenance

Replacing the Dehumidifier Filter

RKI Instruments, Inc. recommends replacing the dehumidifier filter when it looks wet.

Replacing a Sensor

See “Replacing the PID Sensor” on page 94 for sensor replacement instructions.

Replacing the PID Sensor’s Lamp and Electrode Stack

RKI Instruments, Inc. recommends that you replace the electrode stack every time you replace the lamp. However, if you replace only the lamp and notice that the instrument is operating properly, it is not necessary to change the electrode stack.

See “Replacing the PID Sensor’s Lamp” on page 102 and “Replacing the PID Sensor’s Electrode Stack” on page 105 for PID sensor maintenance instructions keeping in mind the following differences in spare parts.

Part Number	Description
33-0564	PID sensor electrode stack, 11.7 eV sensor
51-1504	PID sensor replacement lamp, 11.7 eV sensor
PID-004	PID sensor, 11.7 eV

Cleaning the 11.7 eV PID Sensor's Lamp

Since the life of the 11.7 eV lamp is typically only 3 months, cleaning the lamp is not normally needed. However, if the sensor is exposed to high-molecular-weight VOCs, silicones, or amines, the lamp should be cleaned.

See “Cleaning the PID Sensor’s Lamp, 10.0 eV and 10.6 eV Lamps” on page 98 for instructions to clean the lamp keeping in mind that you are using anhydrous methanol instead of aluminum oxide.

CAUTION: *The aluminum oxide cleaning kit described on pg.98 is only for use with the 10.0 eV and 10.6 eV PID sensors’ lamps. DO NOT USE THE ALUMINUM OXIDE CLEANING KIT TO CLEAN THE 11.7 eV PID SENSOR’S LAMP!*

Cleaning Kit

The 11.7 eV PID sensor cannot be cleaned with the same cleaning kit as the 10.0 eV and 10.6 eV PID sensors!

A special cleaning kit for the 11.7 eV PID sensor is not included with the instrument. See Table 19 on page 172 for the 11.7 eV lamp cleaning kit ordering information.

The 11.7 eV PID sensor lamp cleaning kit includes the following items:

- an electrode stack removal tool
- a small vial of anhydrous methanol (you may purchase your own anhydrous methanol but do NOT use anything with water in it)
- 10 cotton swabs
- 10 finger cots

When using the anhydrous methanol, try to minimize the vial’s exposure to air by leaving the cap on as much as possible. Discard the anhydrous methanol 3 months after opening or after leaving the cap off for an extended period of time.

CAUTION: *Using the anhydrous methanol more than 3 months after opening it or after the cap has been off for an extended period of time may damage the 11.7 eV lamp.*

Parts List for 11.7 eV PID Instruments

The table below lists spare parts for a 11.7 eV PID instrument.

Table 19: Spare Parts List for 11.7 eV PID Instruments

Part Number	Description
07-0220	Rubber cap, black, for dehumidifier filter and GX-6000 inlet fitting
33-0564	PID sensor electrode stack, 11.7 eV sensor
33-2125-01	Dehumidifier filter with tubing
51-1504	PID sensor replacement lamp, 11.7 eV sensor
81-0103RK-03	Calibration cylinder, isobutylene, 100 ppm in air, 103 liter
81-0103RK-04	Calibration cylinder, isobutylene, 100 ppm in air, 34 liter aluminum
81-0143RK-02	Calibration cylinder, 5-gas (Proprietary blend of IBL, CH ₄ , O ₂ , H ₂ S, CO), 58-liter aluminum
81-0143RK-04	Calibration cylinder, 5-gas (Proprietary blend of IBL, CH ₄ , O ₂ , H ₂ S, CO), 34-liter aluminum
81-6ABX-DLV	Calibration kit: 34 liter five-gas (IBL/CH ₄ /O ₂ /H ₂ S/CO) cylinder, demand flow regulator, calibration tubing
82-0301	Anhydrous methanol PID lamp cleaning kit, with electrode stack removal tool, for 11.7 eV sensor's lamp ONLY
PID-004	PID sensor, 11.7 eV

Appendix E: Creating a PID User List

Overview

This appendix explains how to set up a User List for the GX-6000's PID sensor(s). This User List appears in the PID Gas Name Screen in the GX-6000's Display Mode. The PID User List is not related to the GX-6000's User ID list.

Materials

In order to set up the GX-6000's PID User List, you will need:

- IrDA/USB cable
 - GX-6000
 - PID Gas List Editor program
 - computer with Windows 7, Windows 8, or Windows 10
-

Procedure

Installing the PID Gas List Editor Program

1. Double click the setup.exe file.
2. Follow the Setup Wizard prompts to install the program.

Connecting a GX-6000

1. Plug your IrDA/USB cable into your computer.
2. Launch the PID Gas List Editor Program (appears as "GX-6000PID" in the program list).
3. Align the IrDA/USB cable with the GX-6000's IrDA window (located directly below the POWER/ENTER button).
4. Press and release the POWER/ENTER button to turn on the GX-6000.
5. When a connection is established, the GX-6000's LCD will say "PC TRANSMIT". The PID Gas List Editor Program does not show any connection indication.

Editing the User List

1. There are separate PID User Lists for each PID sensor type (10.6 eV, 10.0 eV, 11.7 eV). Be sure that the selected sensor type is the type you would like to edit. The example below shows the 10.6 eV sensor type selected.
2. Select the **Show User List** box. The complete gas list will display on the left side of the screen and the PID User List will display on the right side of the screen.

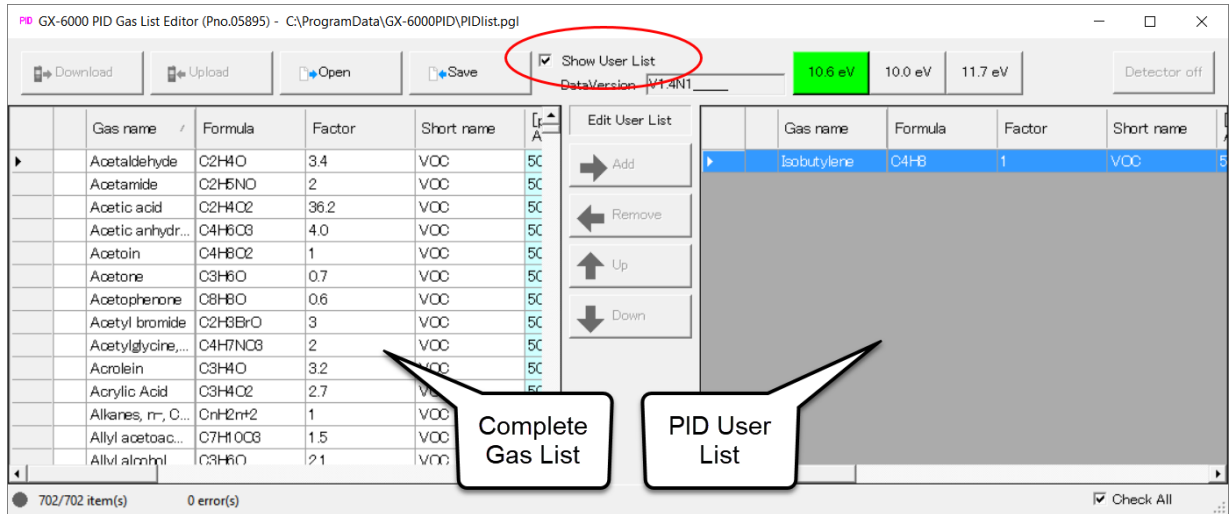

3. To import a previously-saved PID User List:
 - a. Click **Open**.
 - b. Navigate to your saved file, select it, and click **Open**.
 - c. The saved files are specific to sensor type. By default, only file types appropriate for the selected sensor type will display as you navigate to your saved file. *Do not attempt to import a file type that is inappropriate for the selected sensor type.*

Sensor Type	File Type
10.6 eV	.pgl
10.0 eV	.pxl
11.7 eV	.pul

4. To add a gas to the PID User List:
 - a. Select the gas in the Complete Gas List.
 - b. Click **Add**.
5. To remove a gas from the PID User List:
 - a. Select the gas in the PID User List.
 - b. Click **Remove**.

- 6 . To reorder the gases in the PID User List:
 - a. Select a gas in the PID User List.
 - b. Click **Up** and **Down** to move the selected gas up or down. The gas order shown in the PID User List is how the gases will appear when you access the User List in the GX-6000's PID Gas List Screen.
- 7 . If you want to save the PID User List, making it easy to put the load the same PID User List into multiple instruments, click **Save**. Each Save operation only saves the currently displayed list. If you want to create PID User Lists for each sensor type (10.6 eV, 10.0 eV, or 11.7 eV), each PID User List must be saved separately.
- 8 . Click **Upload** to save the PID User List to the GX-6000.
- 9 . If necessary, repeat Step 3 - Step 8 to edit the PID User Lists for the other PID sensor types (10.6 eV, 10.0 eV, or 11.7 eV). Each sensor type has its own PID User List.
- 10 . Click **Detector off** to turn off the GX-6000.
- 11 . Click the red X to close the PID Gas List Editor program. A window will pop up asking if you want to keep the current list.

Clicking **Yes** makes the currently displayed list the default list. This means when you reopen the PID Gas List Editor Program, the currently displayed list will appear instead of the default list that appeared when you opened the program for the first time.

Clicking **No** leaves the PID Gas List Editor Program's default lists alone. When you reopen the program, you will see the default list and not the currently displayed list.

Warranty

RKI Instruments, Inc. warrants the GX-6000 sold by us to be free from defects in materials, workmanship, and performance for a period of two years from the date of shipment from RKI Instruments, Inc. This includes the instrument and the original sensors. Replacement parts are warranted for 1 year from the date of their shipment from RKI Instruments, Inc. except for replacement sensors which are warranted for 2 years. PID sensors are warranted for 1 year from date of shipment from RKI Instruments, Inc. whether they are new or a replacement part. The 11.7 eV PID sensor's lamp is warranted for 2 months from date of shipment from RKI Instruments, Inc. Any parts found defective within their warranty period will be repaired or replaced, at our option, free of charge. This warranty does not apply to those items which by their nature are subject to deterioration or consumption in normal service, and which must be cleaned, repaired, or replaced on a routine basis. Examples of such items are:

- Absorbent cartridges
- Filter elements, disks, or sheets
- Pump diaphragms and valves
- PID sensor electrode stacks

Warranty is voided by abuse including mechanical damage, alteration, rough handling, or repair procedures not in accordance with the instruction manual. This warranty indicates the full extent of our liability, and we are not responsible for removal or replacement costs, local repair costs, transportation costs, or contingent expenses incurred without our prior approval.

THIS WARRANTY IS EXPRESSLY IN LIEU OF ANY AND ALL OTHER WARRANTIES AND REPRESENTATIONS, EXPRESSED OR IMPLIED, AND ALL OTHER OBLIGATIONS OR LIABILITIES ON THE PART OF RKI INSTRUMENTS, INC. INCLUDING BUT NOT LIMITED TO THE WARRANTY OF MERCHANTABILITY OR FITNESS FOR A PARTICULAR PURPOSE. IN NO EVENT SHALL RKI INSTRUMENTS, INC. BE LIABLE FOR INDIRECT, INCIDENTAL, OR CONSEQUENTIAL LOSS OR DAMAGE OF ANY KIND CONNECTED WITH THE USE OF ITS PRODUCTS OR FAILURE OF ITS PRODUCTS TO FUNCTION OR OPERATE PROPERLY.

This warranty covers instruments and parts sold to users only by authorized distributors, dealers, and representatives as appointed by RKI Instruments, Inc.

We do not assume indemnification for any accident or damage caused by the operation of this gas monitor and our warranty is limited to replacement of parts or our complete goods.