



## TM SERIES (WATER METERS) WITH DISPLAY AND PULSE OUTPUT

FLOME<sup>®</sup> MEC TM Series Water Meters are accurate, economical and designed to last. Choose TM Water Meters for water processing and irrigation applications:

- Meets Schedule 80 PVC specifications
- Standard low-profile display
- Five sizes with two fitting types available
- Flowrates from 1 to 200 gallons per minute

### FEATURES / BENEFITS

- Includes pulse output cable for interfacing with customer equipment.
- Displays in gallons and litres.
- Indicates Batch, Cumulative Totals and Rate of Flow.
- Non-volatile totals means amounts are retained when batteries are replaced or power is lost.
- Lithium battery life: 5 years

## APPLICATIONS

- OEM water treatment equipment / skids
- Sub-metering of facility water usage
- Waste water treatment equipment
- Irrigation
- Batching
- Plant process water
- Water based cooling systems
- Chemical feed systems
- Monitoring clean fluids
- Cooling towers
- Blending

## PRODUCT CONFIGURATION

### PRODUCT IDENTIFIER **1**

**TM** = Water Meter, Schedule 80 PVC

### TURBINE SIZE **2**

**050** = 1/2 inch, **075** = 3/4 inch, **100** = 1 inch,  
**150** = 1-1/2 inch, **200** = 2 inch

### FITTING TYPE **3**

-**LP** = Spigot (Pipe) End  
-**N-LP** = NPT Female

**1 2 3**  
---->>> **TM + 150 + -N-LP = SAMPLE**

## DIMENSIONS

Meter Size	Length " (mm)	Height " (mm)	Width " (mm)
TM050-LP	4.3 (109)	2.5 (64)	2.1 (53)
TM050-N-LP	6.0 (152)	2.7 (68)	2.1 (53)
TM075-LP	4.4 (112)	2.7 (68)	2.1 (53)
TM075-N-LP	6.1 (155)	2.9 (74)	2.1 (53)
TM100-LP	4.5 (114)	2.9 (74)	2.1 (53)
TM100-N-LP	6.5 (165)	3.1 (79)	2.1 (53)
TM150-LP	5.4 (137)	3.6 (91)	2.1 (53)
TM150-N-LP	7.6 (193)	3.8 (97)	2.3 (58)
TM200-LP	5.5 (140)	4.1 (104)	2.4 (61)
TM200-N-LP	7.9 (201)	4.4 (112)	3.5 (89)

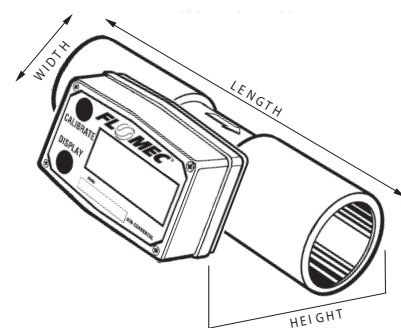

\*Length guidelines are estimates; actual length can vary up to ± 1/2".

## SPECIFICATIONS

<b>Fitting Type:</b>	Schedule 80 Spigot (Pipe) End	
	NPT (Female)	
<b>Meter Sizes Available:</b>	<b>1/2" 3/4" 1" 1-1/2" 2"</b>	
<b>Flow Range:</b>	1/2" (050)	1 - 10 GPM
	3/4" (070)	2 - 20 GPM
	1" (100)	5 - 50 GPM
	1-1/2" (150)	10 - 100 GPM
	2" (200)	20 - 200 GPM
<b>Accuracy (% of Reading):</b>	± 3.0%	
<b>Pressure Rating:</b>	225 PSI @ 73° F (23° C)	
<b>Operating Temperature Range:</b>	+32° F to +140° F	

<b>Typical K-Factor: (Pulses per gallon)</b>	1/2" (050)	2,500 PPG
	3/4" (070)	1,100 PPG
	1" (100)	565 PPG
	1-1/2" (150)	215 PPG
	2" (200)	100 PPG
<b>Wetted Materials:</b>	Housing:	PVC
	Bearings:	Ceramic
	Shaft:	Tungsten Carbide
	Rotor:	PVDF
	Rings:	316 Stainless Steel
<b>Calibration Report:</b>	Comes standard.	
	N.I.S.T. – Certification available.	

## ACCESSORIES / ELECTRONICS

Part No.	Description
113520-1	Battery Replacement Kit
116000-1	Calibration Container, Large (5 gallon)
125508-03	½ inch, Turbine Assy Kit
125508-04	½ inch NPT, PVC Turbine Assy Kit
125510-03	¾ inch, Turbine Assy Kit
125510-04	¾ inch NPT, PVC Turbine Assy Kit
125512-03	1 inch, Turbine Assy Kit
125512-04	1 inch NPT, PVC Turbine Assy Kit
125514-03	1 ½ inch, Turbine Assy Kit
125514-04	1 ½ inch NPT, PVC Turbine Assy Kit
125516-03	2 inch, Turbine Assy Kit
125516-04	2 inch NPT, PVC Turbine Assy Kit
901002-52	Seal

Part No.	Description
<b>Computer Kits:</b>	
125509-04	½ inch, Computer Assy Kit w/Pulse
125511-04	¾ inch, Computer Assy Kit w/Pulse
125513-04	1 inch, Computer Assy Kit w/Pulse
125515-04	1 ½ inch, Computer Assy Kit w/Pulse
125517-04	2 inch, Computer Assy Kit w/Pulse
113275-1	FM Approved Remote Kit Assembly (will not make meter FM Approved)
125206-01	90° Display Adapter Kit

## APPROVALS



**Service & Warranty:** For technical assistance, warranty replacement or repair contact your **FLOMEC™** or **GPI®** distributor. In North or South America: **888-996-3837 / GPI.net**  
Outside North or South America: **+61 2 9540 4433 / flomec.com.au**

Wichita · Sydney · Mexico City

GREAT PLAINS INDUSTRIES 