

User Manual

U1000 V2 Ultrasonic Flowmeter



Original instruction manual

Follow the instruction manual

The instruction manual is part of the product and is an important element of the safety concept.

- ▶ Read and follow the instruction manual.
- ▶ Always keep the instruction manual available at the product.
- ▶ Pass on the instruction manual to all subsequent users of the product.

Contents

1	Intended use	3
2	About this document	3
2.1	Warnings	3
2.2	Other related documents	4
2.3	Abbreviations	4
3	Safety and responsibility	4
4	Transport and storage.....	5
5	Design and function.....	5
5.1	Design.....	5
5.2	Principle of operation	5
5.3	User Interface	6
6	Technical specifications	7
6.1	Default values	8
7	Scope of delivery	9
8	Installation	9
8.1	Positioning the transducers.....	9
8.2	Preparation	10
8.3	Start-Up.....	10
8.4	Adjusting the sensor distance.....	12
8.5	Mounting the U1000 V2 on the pipe	14
8.5.1	Selecting the pipe adapter	14
8.5.2	Apply sound-conductive paste	15
8.5.3	Mounting the guide rail	15
8.5.4	Install the electronics module	16
8.6	Moving the guide rail	16
8.7	Electrical connection of the U1000 V2	17
8.8	4-20 mA, Pulse option	17

8.8.1	Interface cable	17
8.8.2	Pulse output	18
8.8.3	4-20 mA Output	18
8.9	Modbus option	18
8.9.1	Interface cable	18
8.9.2	Modbus connections	19
9	Operation	19
9.1	Entering the pipe inside diameter	19
9.2	Setting the pulse output	21
9.3	Current output 4 - 20 mA	21
9.4	Modbus	21
9.5	Switching off and on again	23
10	Password-protected menus	23
10.1	Overview	23
10.2	Opening a password-protected menu	23
10.3	Changing the selection menus	24
10.4	Changing the numerical values in data menus	24
10.5	Password-protected menu structure	25
10.5.1	Overview	25
10.5.2	Setup	26
10.5.3	Pulse output	29
10.5.4	Current output	29
10.5.5	Calibration	30
10.5.6	Total	30
11	Diagnosis	31
12	Maintenance	31
12.1	Maintenance plan	32
13	Troubleshooting	32
13.1	Flow errors and warnings	32
13.2	Error messages	32
13.3	Modbus Error Messages	34
14	Removal	35
15	Disposal	35

1 Intended use

The U1000 V2 ultrasound flowmeter is used to obtain an optimal measurement of the volume flow and flow rate in steel and plastic pipes with outside diameter from 22 mm (0.86") to 180 mm (7").

Measurable pipe sizes are dependent on pipe material and inner pipe diameter.

Typical applications

- ▶ Hot water metering and flow measurement
- ▶ Flow measurement and heat measurement
- ▶ Cold water metering and flow measurement
- ▶ Tap water metering and flow measurement
- ▶ Service water metering and flow measurement
- ▶ High-purity water metering and flow measurement

2 About this document

This document contains all the information necessary for installation, operation and maintenance of the product.

2.1 Warnings

This instruction manual contains warning notices that alert you to the possibility of injuries or damage to property. Always read and pay attention to these warnings!



Risk of fatal or serious injury!

There is a risk of fatal or serious physical injury if warnings are ignored!



Danger of minor physical injury!

Failure to pay attention to these warnings will lead to a risk of physical injury!



Risk of damage to property!

Failure to comply leads to a risk of damage to property (loss of time, loss of data, device fault etc.)!

Other symbols

Symbol	Meaning
1.	Actions required in a numbered sequence.
▶	Actions required
•	Listing of items on various levels
.	

2.2 Other related documents

- Georg Fischer industrial planning fundamentals

These documents are available through agents of GF Piping Systems or at www.gfps.com.

2.3 Abbreviations

Abbreviation	Description
ABS	Acrylonitrile-butadiene-styrene
DA	Double acting function
EMC	Electromagnetic Compatibility
FC	Fail safe to close function
FO	Fail safe to open function
LCD	Liquid crystal display
LED	Light-emitting diode
MOSFET	Metal oxide semiconductor field effect transistor
PB-INSTAFLEX	Polybutene plastic piping system
PE-ELGEF	Polyethylene plastic piping system
PP-PROGEF	Polypropylene plastic piping system
PVDF-SGEF	PVDF (polyvinylidene fluoride) plastic piping system
SPNO MOSFET	Single-pole normally open metal oxide semiconductor field effect transistor
VC-U-PVC	Polyvinyl chloride

3 Safety and responsibility

- ▶ Only use the product for the intended purpose, see Intended Use.
- ▶ Do not use any damaged or faulty product. Sort out any damaged product immediately.
- ▶ Make sure that the piping system has been installed professionally and that it is inspected regularly.
- ▶ Have the product and accessories installed only by persons who have the required training, knowledge or experience.

- ▶ Regularly train personnel on all questions regarding the locally regulations applying to occupational safety and environmental protection, especially for pressurised pipelines.

4 Transport and storage

- ▶ Protect the product against external forces during transport (impacts, knocks, vibrations etc.).
- ▶ Transport and / or store the product unopened in its original packaging.
- ▶ Protect the product from dust, dirt, moisture as well as heat and ultraviolet radiation.
- ▶ Ensure that the product is not damaged either by mechanical or thermal influences.
- ▶ Before assembling, check the product for damage during transport.

5 Design and function

5.1 Design



1	Power supply (AC/DC)	4	Guide rail
2	Pipe clamp	5	User interface
3	Electronics module	6	Pipe

The U1000 V2 consists of an electronics module (3) and a guide rail (4), which together form a single unit which is fixed to the pipe (6) by pipe clamps (2).

The U1000 V2 is supplied with power through an external 12 – 24 V power adapter (1).

5.2 Principle of operation

The U1000 V2 takes accurate flow measurements by determining the difference between the transmission times of two ultrasound signals.

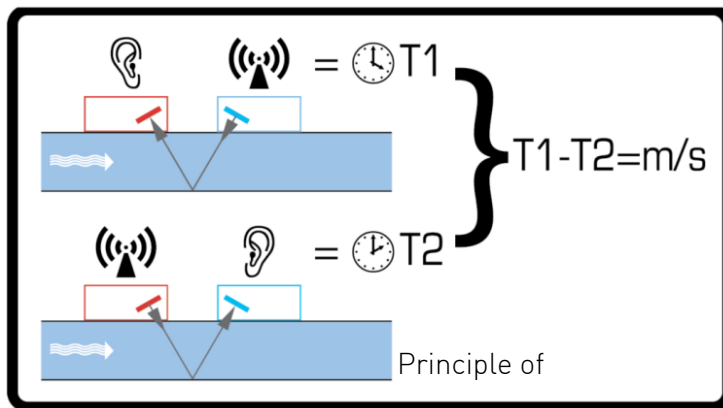

A periodic voltage pulse acts on the transducer crystals and produces an ultrasound beam at a certain frequency. The beam is first transmitted by the downstream transducer (blue) to the upstream transducer (red).

The beam is then sent in the opposite direction, i.e. from the upstream transducer (red) to the downstream transducer (blue). The time taken for the ultrasound to pass through the liquid in this direction is slightly shortened by the speed at which the liquid flows through the pipe.

The resulting time difference $T1 - T2$ is directly proportional to the speed at which the liquid flows through the pipe.

5.3 User Interface

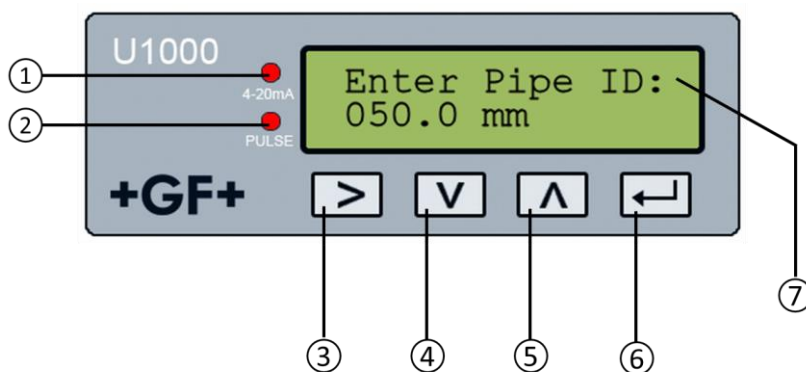

1	LED 4 - 20 mA is lit when the current output is active
2	LED Pulse is lit when the pulse output is active
3	Button (selection button) switches backwards and forwards through the displayed options
4	Button (reduce value) reduces the value incrementally in the digital input fields
5	Button (increase value) increases the value incrementally in the digital input fields
6	Button (confirm input) confirms the value displayed, ends data input, changes to another menu or the flow values screen
7	LCD display with backlighting (2 rows x 16 characters)

6 Technical specifications

Data	Kv value	
Measurement technology	Transmission time	
Measurement channels	1	
Resolution of time calculation	± 50 ps	
Dynamics (turn-down ratio)	200:1	
Flow rate	0.1m/s - 10m/s (0.3 ft/s - 32 ft/s)	
Usable liquid types	High purity water, clean water with < 3 percent by volume of particle content, or up to 30% ethylene glycol.	
Accuracy	± 3 % of flow value with a flow rate of > 0.3 m/s	
Repeatability	± 0.15 % of measured value	
Selectable units of measurement	Flow rate	m/s, ft/s
	Volume flow	l/s, l/min, m ³ /min, m ³ /hr gal/s, gal/min, USgal/s, USgal/min
	Volume	l, m ³ , gals, USgals
Languages supported	English	
Power input	12 – 24 V (AC or DC)	
Power consumption	7 VA max.	
Cable	5 m shielded (6-wire)	
Pulse output		
Output	Opto-isolated MOSFET volt free contact (NO/NC)	
Insulation	2500 V	
Pulse width	Default value	50 ms
	Programmable range	3 – 99 ms
Pulse repeat rate	Up to 166 pulses/s (depending on pulse width)	
Frequency based mode	200 Hz max. (Range 1-200)	
Max. voltage/current load	48 V AC / 500 mA	
Current output		
Output	4 – 20 mA	
Resolution	0.1 % of total scale	
Maximum load	620 Ω	
Insulation	1500 V optically insulated	
Alarm current	3.5 mA	
Housing		

Data	Kv value
Material	Polycarbonate
Mounting	Pipe mountable
Protection class	IP54
Fire classification	UL94 V-0
Dimensions	250 mm x 48 mm x 90 mm (electronics + guide rail)
Weight	0.5 kg
Ambient conditions	
Pipe temperature	0 °C to +85 °C
Operating temperature (electronics)	0 °C to +50 °C
Storage temperature	-10 °C to +60 °C
Humidity	90% relative humidity at < 50 °C
Display	
LCD	2 lines x 16 characters
Viewing angle	30° min., 40° max.
Active area (W) x (H)	58 mm x 11 mm
Keypad	
Format	Keypad with 4 buttons

6.1 Default values

The settings are configured at the factory for either metric or imperial dimensions and weights.

Parameters	Metric dimensions	Imperial dimensions
Dimensions	mm	Inches
Volume flow	l/min	USgal/min
Pipe size	50 mm	2"
4 - 20 mA	On	On
Pulse output	Off	Off
Volume per pulse	10 l	10 US gallons
Pulse width	50 ms	50 ms
Damping	20 s	20 s
Calibration factor	1.000	1.000
Zero Cut-off	0.02 m/s	0.07 m/s

Parameters	Metric dimensions	Imperial dimensions
Zero offset	0.000 l/min	0.000 gal/min

7 Scope of delivery

Component	Pcs.
U1000 V2 electronics module	1
Guide rail	1
Gel-Pads	4
Syringe with sound-conductive paste	1
Pipe clamps	2
Cable	1
Adapter for small pipes < 40 mm	1
Adapter for small pipes < 60 mm	1

8 Installation

8.1 Positioning the transducers

The U1000 V2 requires an even and uniform flow profile, since distortions in the flow can cause unpredictable measurement errors.

In many applications, however, it is not possible to have a uniform flow rate through 360°. This may be, for example, because there are air bubbles inside the top of the pipe, or turbulence in the pipe, or sludge at the bottom of the pipe.

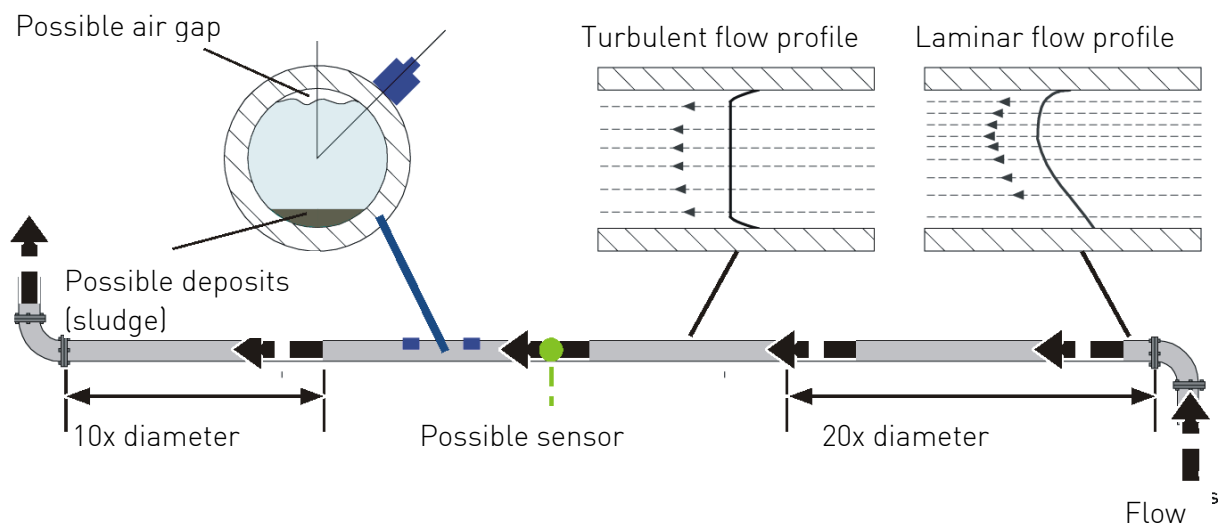

Experience has shown that the most accurate results are obtained if the guide rail of the transducers is not mounted vertically to the pipe, but turned at an angle of about 45° to the right or left on the pipe.

NOTICE**Incorrect measurements**

Measurements can be distorted if the transducers are positioned close to upstream pipe components and fittings such as pipe bends, T-branches, valves, pumps and similar obstacles.

To ensure that the U1000 V2 is positioned at a place that has an undistorted flow profile, the transducers must be mounted sufficiently far from possible sources of distortion to prevent these from having any effect on the measurement.

- Install a straight section of pipe with length 20 times the diameter on the upstream side of the transducer.
In exceptional cases, a pipe with length 10 times the diameter may be sufficient.
- Install a pipe section with length 10 times the diameter on the downstream side of the transducer.
In exceptional cases, a pipe with length 5 times the diameter may be sufficient.

8.2 Preparation



- ▶ Before attaching the transducers, make sure that desired position meets the distance requirements.
See Section 8.1 Positioning the transducers, Page 9.
- ▶ Clean the pipe to remove any grease residues.
- ▶ Remove any dirt and flaking paint in order to ensure an even surface.

NOTICE**Maximum accuracy**

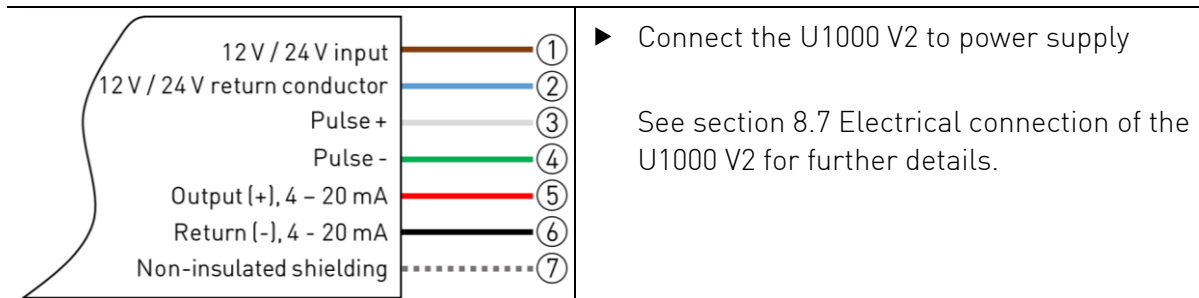
A smooth and even contact between pipe surface and transducer is an important factor for obtaining a sufficiently strong ultrasound signal.

8.3 Start-Up

<p>U1000 4-20mA PULSE +GF+ > V ^ ↩</p>	<ul style="list-style-type: none"> ▶ The U1000 V2 boots for the first time. The GF start screen is displayed for 5 s.
<p>U1000 4-20mA PULSE +GF+ > V ^ ↩</p>	<ul style="list-style-type: none"> ▶ The start-up wizard automatically starts. Enter pipe id menu appears. ▶ Select your pipe inside diameter and press to acknowledge. <p>See Section 9.1 Entering the pipe inside diameter, Page 19 for more details.</p>
<p>U1000 4-20mA PULSE +GF+ > V ^ ↩</p>	<ul style="list-style-type: none"> ▶ Select your pipe material and press to acknowledge.
<p>U1000 4-20mA PULSE +GF+ > V ^ ↩</p>	<ul style="list-style-type: none"> ▶ Select your instrument fluid and press to acknowledge.
<p>U1000 4-20mA PULSE +GF+ > V ^ ↩</p>	<ul style="list-style-type: none"> ▶ Select you media temperature: - 'Cold' for temperature 2 °C to 40 °C - 'Hot' for temperature 40 °C to 85 °C ▶ Press to acknowledge.
<p>U1000 4-20mA PULSE +GF+ > V ^ ↩</p>	<ul style="list-style-type: none"> ▶ The U1000 V2 shows you the correct transducer distance for your application. ▶ Press to acknowledge ▶ Proceed with 8.4 Adjusting the sensor distance
<p>U1000 4-20mA PULSE +GF+ > V ^ ↩</p>	<p>The U1000 V2 searches for a valid signal.</p>
<p>U1000 4-20mA PULSE +GF+ > V ^ ↩</p>	<p>If a valid signal is detected, the signal strength and flow are displayed. The direction of flow at switch-on time is taken as a positive flow value and the current and pulse output refer to this flow direction.</p>

 <p>U1000 4-20mA PULSE +GF+ > V ^ ↩</p>	<p>If the flow direction is reversed, the volume flow is still displayed. The activity indicator changes from a star to an exclamation mark, no more pulses are generated and the 4 – 20 mA current output changes to a 3.5 mA alarm status.</p>
 <p>U1000 4-20mA PULSE +GF+ > V ^ ↩</p>	<p>If the U1000 V2 does not detect a valid signal 'Sig: 00%' is shown. In this case please make sure you followed the steps in section 8.4 Adjusting the sensor distance and 8.5 Mounting the U1000 V2 on the pipe correctly. See also section 13 Troubleshooting for further advice.</p>

8.4 Adjusting the sensor distance

NOTICE

Maximum accuracy

The two sensors must be placed at defined distance relative to each other, where the distance depends on the pipe inside diameter and pipe material.

- ▶ Define optimal sensor distance with entering your pipe credentials in the U1000 V2 start-up wizard (see section 8.3 Start-Up). (E.g. B-4 for PVC-U pipe with 50 mm inside diameter)
- ▶ Loosen the sensor mounting screws.

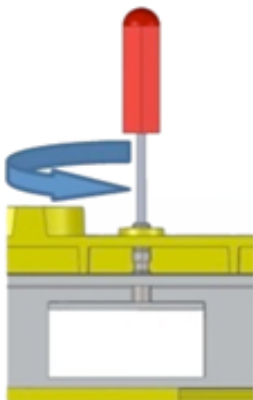

- ▶ Move the sensors to the optimal position (see start-up wizard in section 8.3 Start-Up).



- ▶ Tighten the sensor mounting screws.

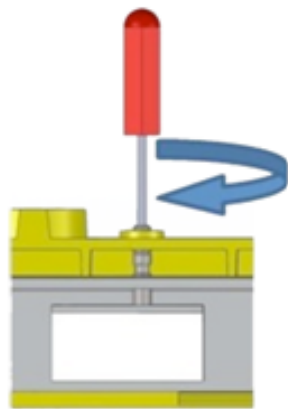

NOTICE

NOTE. When the sensors have been moved to the correct setting and the guide rail is attached to the pipe REMOVE the sensor holding screws, which will allow the spring loaded transducers to make contact with the pipe.

8.5 Mounting the U1000 V2 on the pipe

8.5.1 Selecting the pipe adapter

Two adapters are available for attaching the measuring device to pipes with an outside diameter of ≤ 60 mm.

NOTICE

If these adapters are not necessary, store them away for a possible later change of position.

Outside diameter less than 40 mm – top and bottom pipe adapters (black)

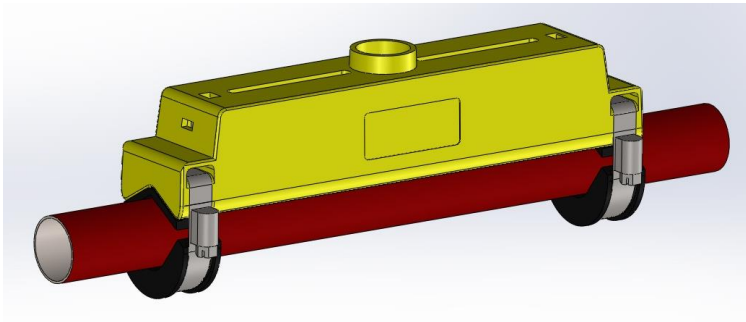

Outside diameter 40 mm – 60 mm – top pipe adapter (black)

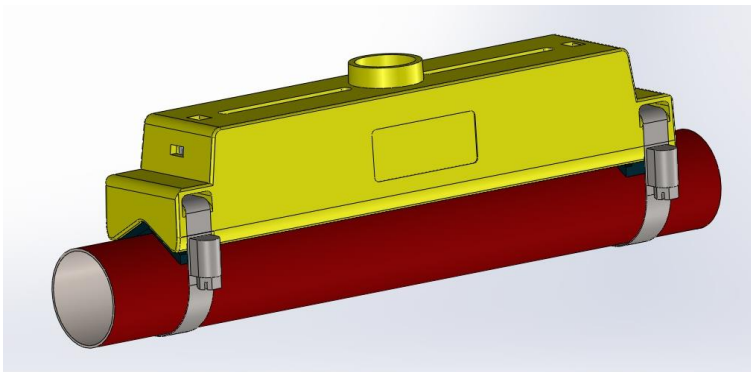

Outside diameter more than 60 mm

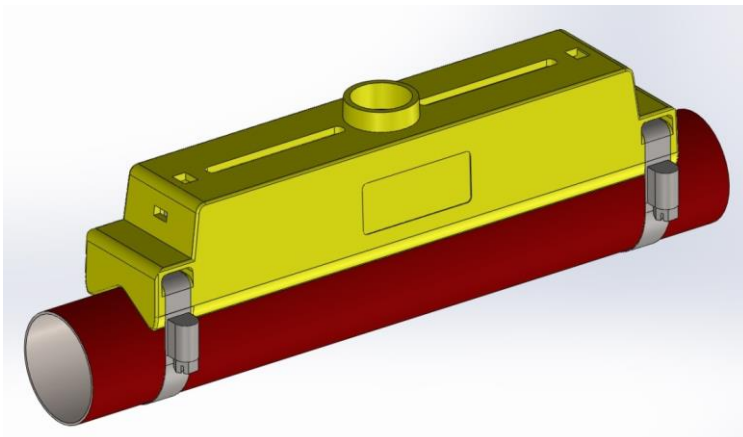

The adapters are placed on the pipe so that the top pipe adapter engages in the end pieces on the guide rail.

8.5.2 Apply sound-conductive paste

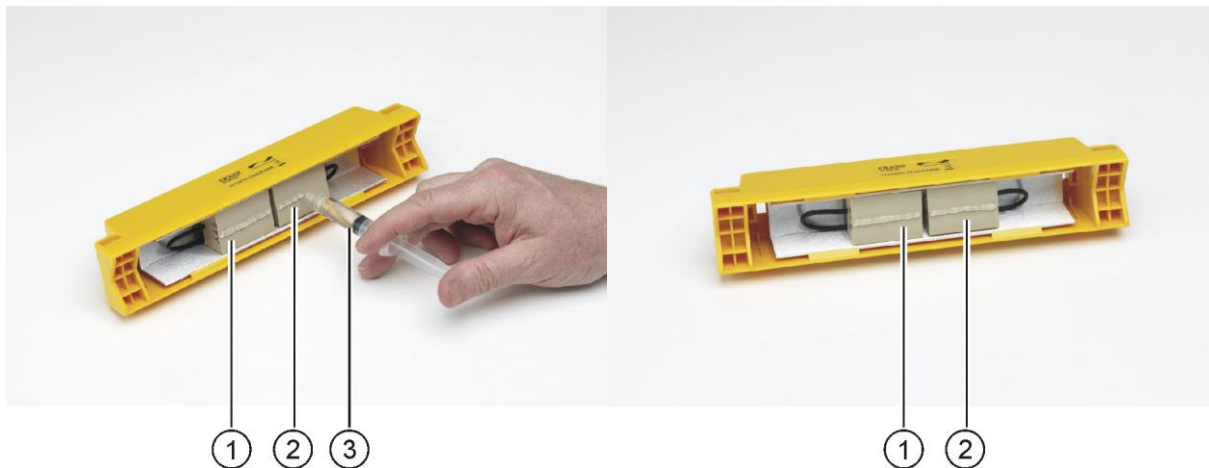

- ▶ Using the syringe, apply sound-conductive paste (3) to the sensor contact surfaces (1) and (2).

8.5.3 Mounting the guide rail

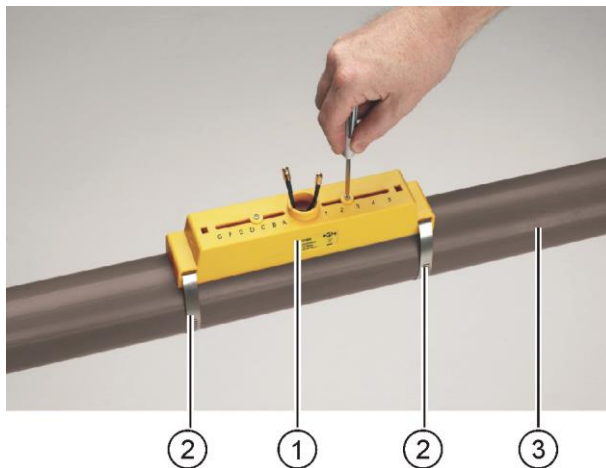

- ▶ Mount the guide rail (1) and pipe adapters if necessary (see section 8.5.1 Selecting the pipe adapter) on the pipe (3) using the pipe clamps (2).
- ▶ Loosen the mounting screws and remove along with the washers.

NOTICE

Store the mounting screws and washers away for future maintenance work or for a possible change of position later.

8.5.4 Install the electronics module

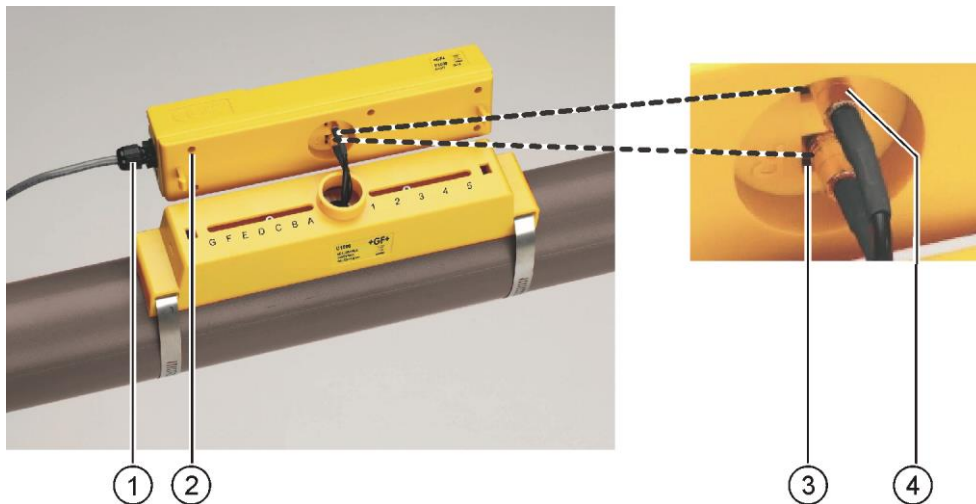

- ▶ Connect the power supply (1) to the electronics module (2).
- ▶ Plug the cables of the two sensors into the sockets (3) and (4) on the electronics module. The cables can be assigned as desired.



- ▶ Set the electronics module (1) on the guide rail (2) and engage it in the clamp connections at both ends.

8.6 Moving the guide rail

If it becomes necessary to change the position of the guide rail or the sensors:

- ▶ Remove complete assembly from the pipe.
- ▶ Undo the screw at the end of the guide rail and gently lift the same end as shown.



- ▶ The opposite end of the electronics can now be released from the guide rail.
- ▶ Disconnect the sensors.
- ▶ Remove the original Gel pads from the sensors.

- ▶ Push the sensor blocks into the guide rail so that the washers and locking screws can be refitted.
- ▶ Place replacement Gel pads down the centre of the sensor block.
- ▶ Follow the procedure in section 8.5 for re-installing the guide rail on the pipe.

8.7 Electrical connection of the U1000 V2

NOTICE

The U1000 V2 operates in the voltage range 12 – 24 V (AC/DC). The power supply must have a minimum rating of 7 VA per instrument. To fully meet the requirements of EMC regulations, a 12 V connection is recommended for domestic and light industrial applications.

For full immunity to electrical interference the screen of the power/pulse output cable and modbus cable should be connected to Earth.

For safety, connecting the U1000 V2 to a power supply via a mains rated transformer is the responsibility of the installer to conform to the regional voltage safety directives.

Connect the external power supply to the Brown and Blue wires of the six-core cable.

8.8 4-20 mA, Pulse option

- ▶ Connect the external power supply to the Brown and Blue wires of the six-core cable.
- ▶ Connect the White and Green wires to Pulse and the Red and Black wires to 4-20 mA input.

8.8.1 Interface cable

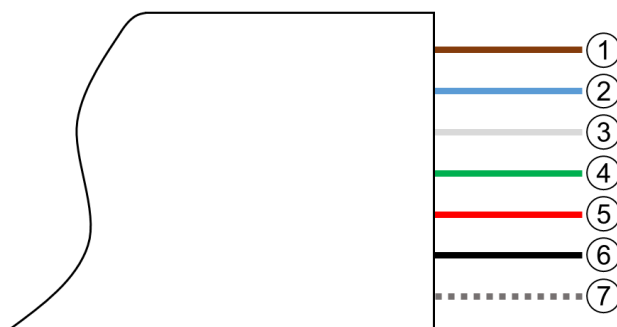

The U1000 V2 6-wire interface cable

1	12 V / 24 V input (brown)	
2	12 V / 24 V return conductor (blue)	
3	Pulse + (white)	The SPNO MOSFET relay in the electronics module supplies an insulated switching signal for a switchable current of up to 500 mA and a voltage of up to 48 VAC. This relay also provides 2500 V insulation. Galvanically speaking, it is a volt free output.
4	Pulse - (green)	
5	Output (+), 4 – 20 mA (red)	

6	Return conductor (-), 4 - 20 mA (black)	The 4 - 20 mA current output is an insulated current source designed for loads of $< 620 \Omega$. The alarm current is triggered by flows outside the specified range or by signal loss, and is set at 3.5 mA.
7	Non-insulated shielding	



Electric shock due to short-current!

Before connecting the U1000 V2 to an external power supply, make sure that the power supply is switched off.

8.8.2 Pulse output

The isolated pulse output is provided by a SPNO/SPNC MOSFET relay which has a maximum load current of 500mA and maximum load voltage of 48V AC. The relay also provides 2500V isolation, between the sensor's electronics and the outside world.

The pulse output is available at the White and Green wires. Electrically this is a volt, or potential free contact, and when selected as a low flow alarm is configurable NO/NC.

8.8.3 4-20 mA Output

The isolated 4-20mA is a current source and can drive into a maximum load of 620Ω .

The 4-20mA current output is available at the Red and Black wires.

The alarm current due to a flow outside the range specified or due to a loss of signal is set at 3.5mA.

8.9 Modbus option

8.9.1 Interface cable



1	Modbus -ve (brown)
2	Modbus ground (white)
3	Modbus +ve (black)
4	Modbus ground (white)
5	Modbus optional ground (uninsulated screen)

8.9.2 Modbus connections

A lead is provided for the Modbus connections that plugs into the electronics assembly near the power cable entry. The Brown is the -ve bus wire and the Black is the +ve bus wire. Both White wires go to ground.

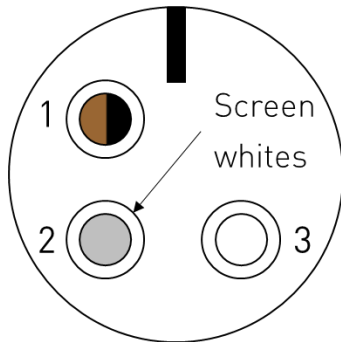









Pin	Function	Colour
1	Modbus -ve	Black & brown
2	Optional ground	Screen
3	Modbus +ve	Both whites
4	-	

For reliable operation of a Modbus network the cable type and installation must comply with requirements in the Modbus specification document "MODBUS over Serial Line Specification & Implementation guide V1.0".

9 Operation

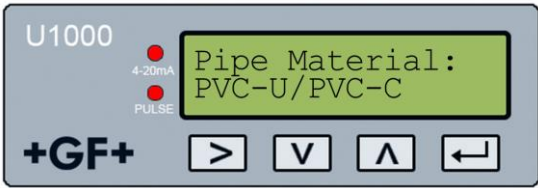
9.1 Entering the pipe inside diameter

	<p>▶ Switch on the U1000 V2 for the first time. The GF start screen is displayed for 5 s.</p> <p>The hundreds digit (050.0) for the pipe inside diameter flashes.</p>
	<p>▶ Press the button. The flashing hundreds digit (050.0) increases from 0 to 1.</p>
	<p>▶ Press the button. ▶ The flashing hundreds digit (050.0) decreases from 1 to 0.</p>
	<p>▶ Press the button. The tens digit (050.0) flashes.</p>
	<p>▶ Press the button. The flashing tens digit (050,0) increases through the number sequence 0, 1, 2, 3, 4, 5, 6, 7, 8, 9, 0.</p>

	<ul style="list-style-type: none"> ▶ Press and hold the button. The number sequence scrolls automatically.
	<ul style="list-style-type: none"> ▶ Press the button. The flashing tens digit (050,0) decreases through the number sequence 9, 8, 7, 6, 5, 4, 3, 2, 1, 0. ▶ Press and hold the button. The number sequence scrolls automatically.
	<ul style="list-style-type: none"> ▶ Press the button. The ones digit (005.0) flashes. ▶ Set a value in the same way as for the tens digit.
	<ul style="list-style-type: none"> ▶ Press the button. The decimal digit (000.5) flashes. ▶ Set a value in the same way as for the tens digit.
	<ul style="list-style-type: none"> ▶ Press the button. The entered value is stored and the next screen is displayed: 
	<ul style="list-style-type: none"> ▶ Press the button. The list of pipe materials scrolls upward. ▶ Press and hold the button. The list scrolls automatically.
	<ul style="list-style-type: none"> ▶ Press the button. The list of pipe materials scrolls downward. ▶ Press and hold the button. The list scrolls automatically.
	<ul style="list-style-type: none"> ▶ Press the button. The selected pipe material is stored and the input procedure ends.

If it is necessary to change the preset parameter values (for example, if a different measurement unit is required), then a password must be entered to open the system menu. See Section 10 Password-protected menus, Page 23.

9.2 Setting the pulse output

The pulse output can be set in two different operating modes:

Volume based mode

- After a measured volume of 10 l (preset value), a pulse is sent => 1 pulse/10 l.
- The maximum number of pulses that can be sent without storing is calculated using the two default parameters **Vol per pulse =1** and **Pulse width = 25 ms**, with the formula $1/(0.025 \times 2)$ giving a value of **20 pulses/s**.
- If the volume flow in the pipe is so high that more than 20 pulses/s are generated, a pulse overload error may occur if the number of stored pulses exceed a value of 1,000.
- To avoid this, the **Vol per pulse** value can be adjusted as necessary.
See Section 10 Password-protected menus, Page 23.

Frequency based mode

In frequency-based mode, the pulse output frequency is proportional to the volume flow within a frequency range of 0 – 200 Hz.

9.3 Current output 4 - 20 mA

- The preset output value of 4 - 20 mA is active if the 4 - 20 mA LED is lit.
- The preset flow value for the 20 mA output is calculated automatically according to the set pipe size.
- The preset flow value for the 4 mA output is 0. To change this, see Section 10 Password-protected menus, Page 23.
- If the flow value is greater than the value set for the 20 mA output, or there is negative flow, or a flow signal cannot be detected, then an alarm current of 3.5 mA is generated.

NOTICE

The 4- 20 mA current output is pre-calibrated ex works.

9.4 Modbus

The Modbus RTU interface is configured via the Modbus sub menu in the password controlled menu.

The data rate can be selected in the range 1200 to 38400 baud.

The address can be set in the range 1 to 126.

Polling Rate 1000ms (1sec). Time out after 5 seconds.

The instrument responds to the “read holding registers” request (CMD 03).

If the flow reading is invalid then the flow value will be zero.

If a temperature sensor goes out of range then the value will go to -11.

Both of these faults will set the relevant status bit. The following registers are available.

On a unit set to Imperial the flow in US Gallons.

Modbus Register	Register Offset	Type	Typical Contents	Meaning	Notes		
n/a	n/a	Byte	0x01	Instrument Address	-		
n/a	n/a	Byte	0x03	Instrument Command	-		
n/a	n/a	Byte	0x40	Number of bytes to read	-		
40001	0	Int-16	0x00	Device ID			
			0xac				
40002	1	Int-16	0x00	Status	0x0000 OK Not[0x0000] Fault		
			0x00				
40003	2	Int-16	0x00	System Type	-		
			0x04				
40004	3	Int-16	0x00	Serial Identifier	-		
			0x01				
40005	4	Int-16	0x23				
			0x45				
40006	5	Int-16	0x60				
			0x00				
40007	6	iee754	0x40			Measured Velocity	Units in m/s
			0x1f				
40008	7	iee754	0x67				
			0xd3				
40009	8	iee754	0x41	Measured Flow	Units in m ³ /hr for Metric Units in US Gal/m for Imperial		
			0x8c				
40010	9	iee754	0xd8				
			0xb0				
40011	10	iee754	0x42	Calculated Power	Units in kW for Metric Units in BTU/s for Imperial		
			0x1c				
40012	11	iee754	0x2e				
			0x34				
40013	12	iee754	0x44	Calculated Energy	Units in kWh for Metric Units in kBTU for Imperial		
			0x93				
40014	13	iee754	0xc6				
			0xc8				

9.5 Switching off and on again

If the power supply is switched off and then on again after the pipe inside diameter is entered for the first time, then the last applied configuration is used.

If the configuration is changed for some reason, the password-protected menu must be used. See Section 10 Password-protected menus, Page 23.

10 Password-protected menus

10.1 Overview



Password-protected menus allow the preset values to be adapted as required:

- ▶ To change the dimensions from mm to inches or vice versa
- ▶ To change from volume flow to flow rate measurement
- ▶ To change between system units l/m³ or Impgal/USgal
- ▶ To change between flow units l/s, l/min or gal/s, gal/min or USgals/s, USgals/min
- ▶ To change the preset value for flow at maximum current
- ▶ To change the preset value for flow at minimum current
- ▶ To change the type of pulse output
- ▶ To change the pulse output parameters

NOTICE

The password for the password-protected area is: 71360.

10.2 Opening a password-protected menu



	<p>Signal strength and the present flow are displayed:</p> 
	<ul style="list-style-type: none"> ▶ Press the button. You are prompted for the password. If the password is not entered, the display automatically changes back to the flow value after a few seconds.
	<ul style="list-style-type: none"> ▶ Enter the password (71360). See Section 10.4 Changing the numerical values in data menus, Page 24.
	<ul style="list-style-type: none"> ▶ Make all the desired changes.
	<ul style="list-style-type: none"> ▶ Press the button. The current parameter is skipped.

	<ul style="list-style-type: none"> ▶ Press the button User Menu: Exit. The new values are stored and the password-protected menu is closed.
---	---

10.3 Changing the selection menus

NOTICE

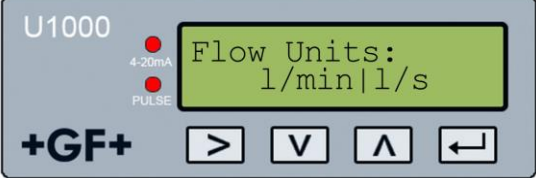
The procedure for changing the preset values is the same for all menus.



	<ul style="list-style-type: none"> ▶ Open the password-protected menu. See Section 10.2 Opening a password-protected menu, Page 23.
	<ul style="list-style-type: none"> ▶ For example, select the Flow Units parameter.
	<p>The current value (l/min) flashes</p>
	<ul style="list-style-type: none"> ▶ Press the button. The value (l/s) flashes.
	<ul style="list-style-type: none"> ▶ Press the button. The new value (l/s) is stored and the next screen is displayed.







10.4 Changing the numerical values in data menus

NOTICE

The procedure for changing numerical values is the same for all menus.

In this example, the preset value for the flow at maximum current is changed from 1,000 l to 1,258 l.

	<ul style="list-style-type: none"> ▶ Open the password-protected menu. See Section 10.2 Opening a password-protected menu, Page 23.
	<ul style="list-style-type: none"> ▶ As an example, select the parameter for the flow at maximum current.
	<p>The tens of thousands digit (01000.0) flashes</p>
	<ul style="list-style-type: none"> ▶ Press the button twice.

	The hundreds digit (01000.0) flashes.
	▶ Press the button twice. The flashing hundreds digit (01000.0) changes to 2 .
	▶ Press the button. The tens digit (01200.0) flashes.
	▶ Press the button five times. The flashing tens digit (01200.0) changes to 5 .
	▶ Press the button. The ones digit (01250.0) flashes.
	▶ Press the button twice. The flashing ones digit (01250.0) changes to 8 .
	▶ Press the button. The new value (01258.0) is stored and the next screen is displayed.

10.5 Password-protected menu structure

10.5.1 Overview

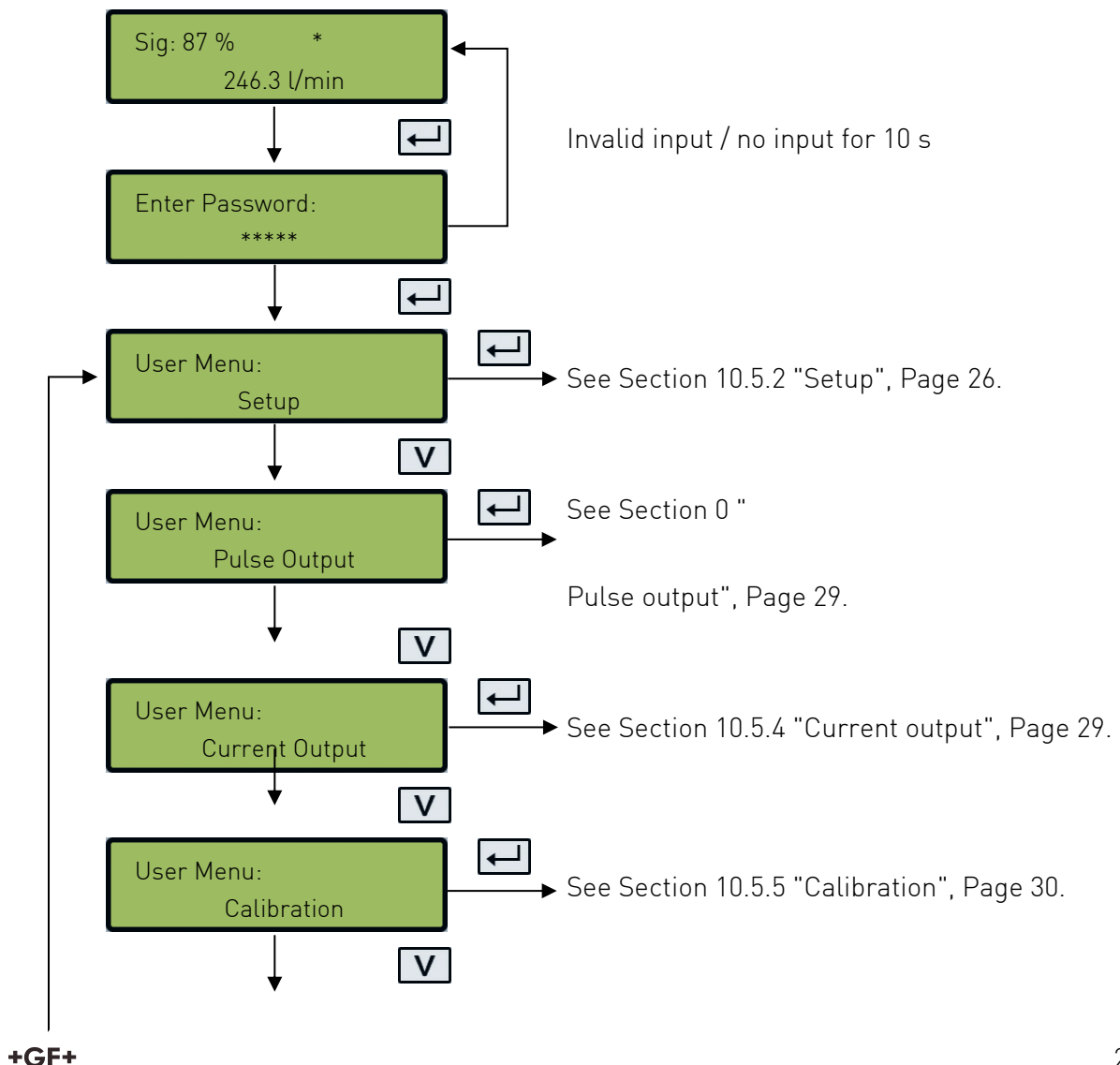

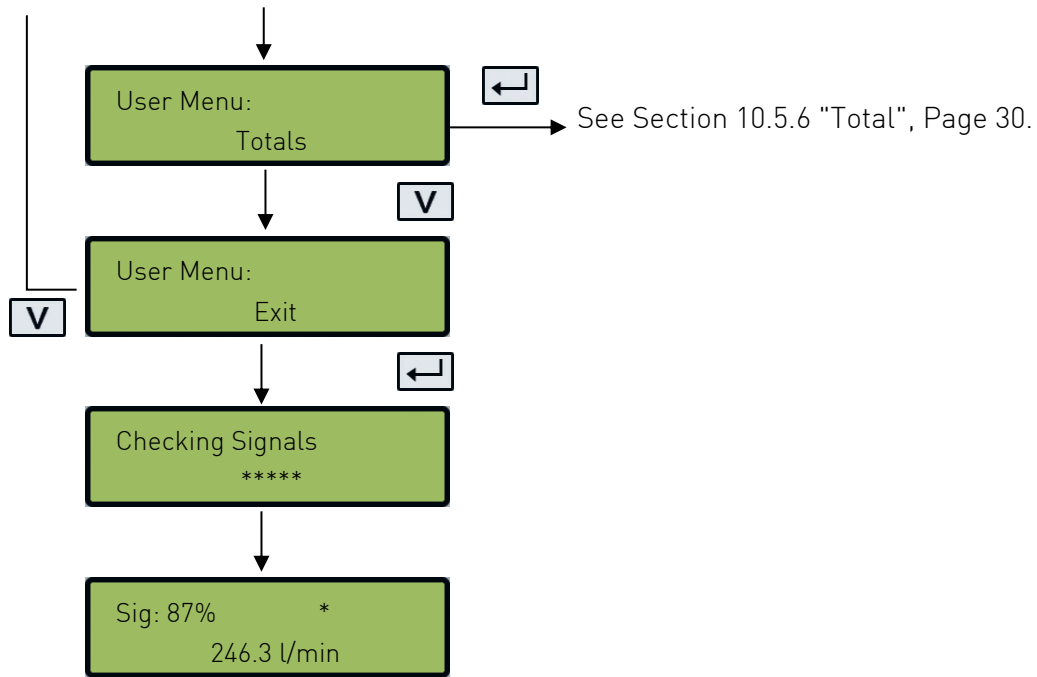

10.5.2 Setup

Metric units

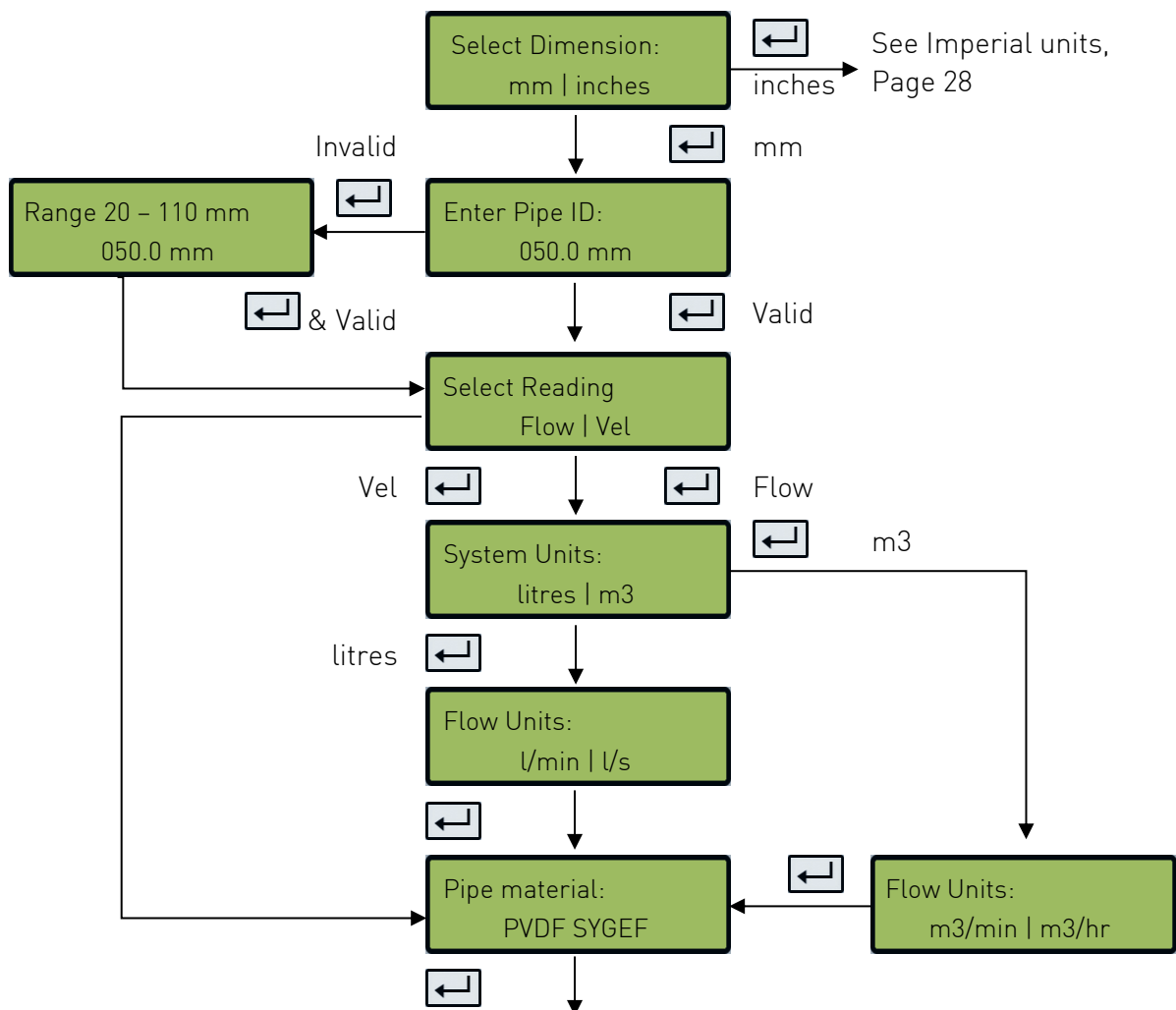

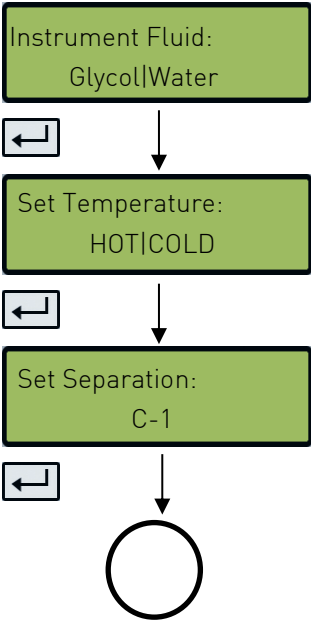

See Section 10.5.1 "Overview",
Page 25.

Imperial units

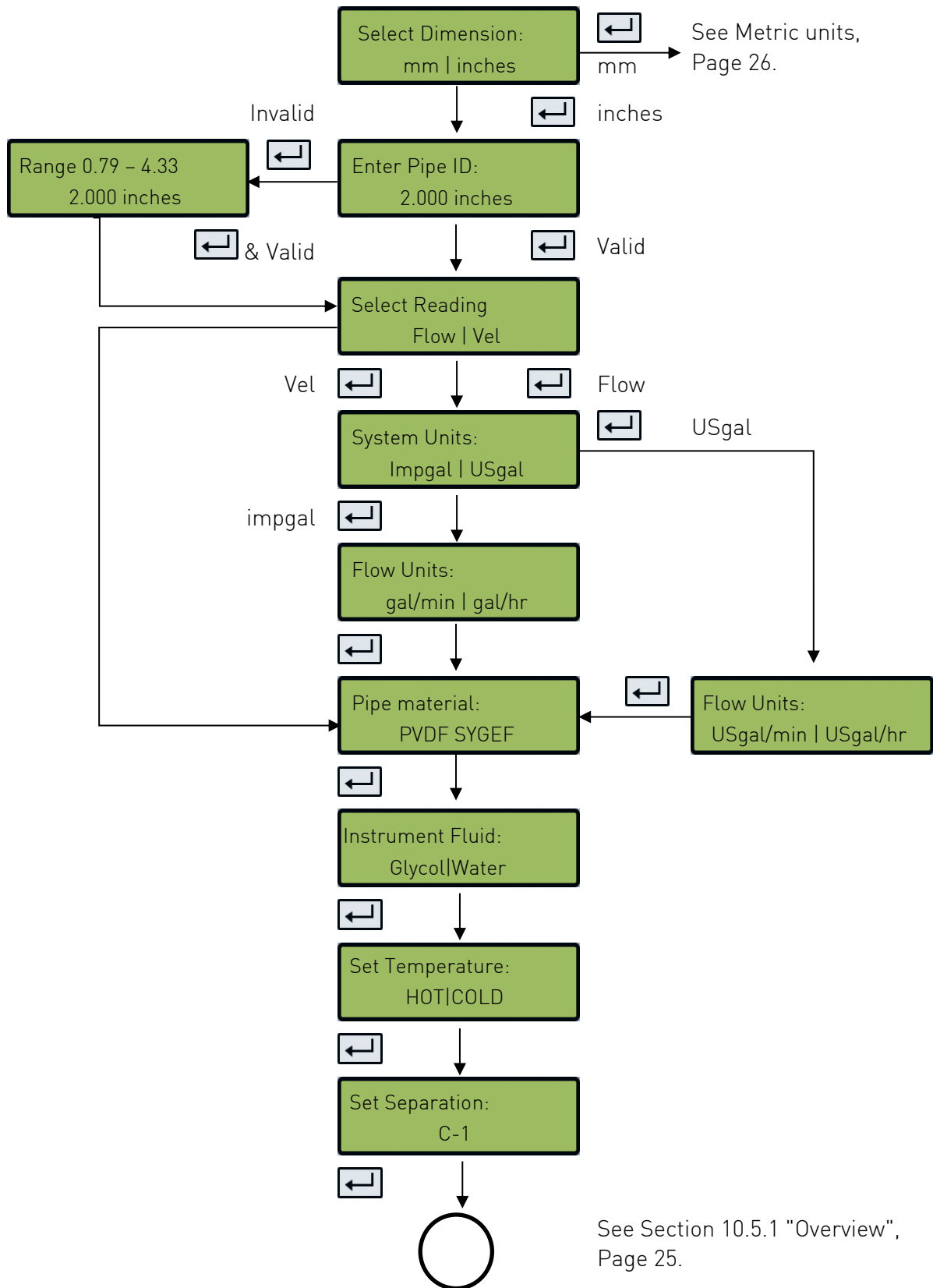

10.5.3 Pulse output

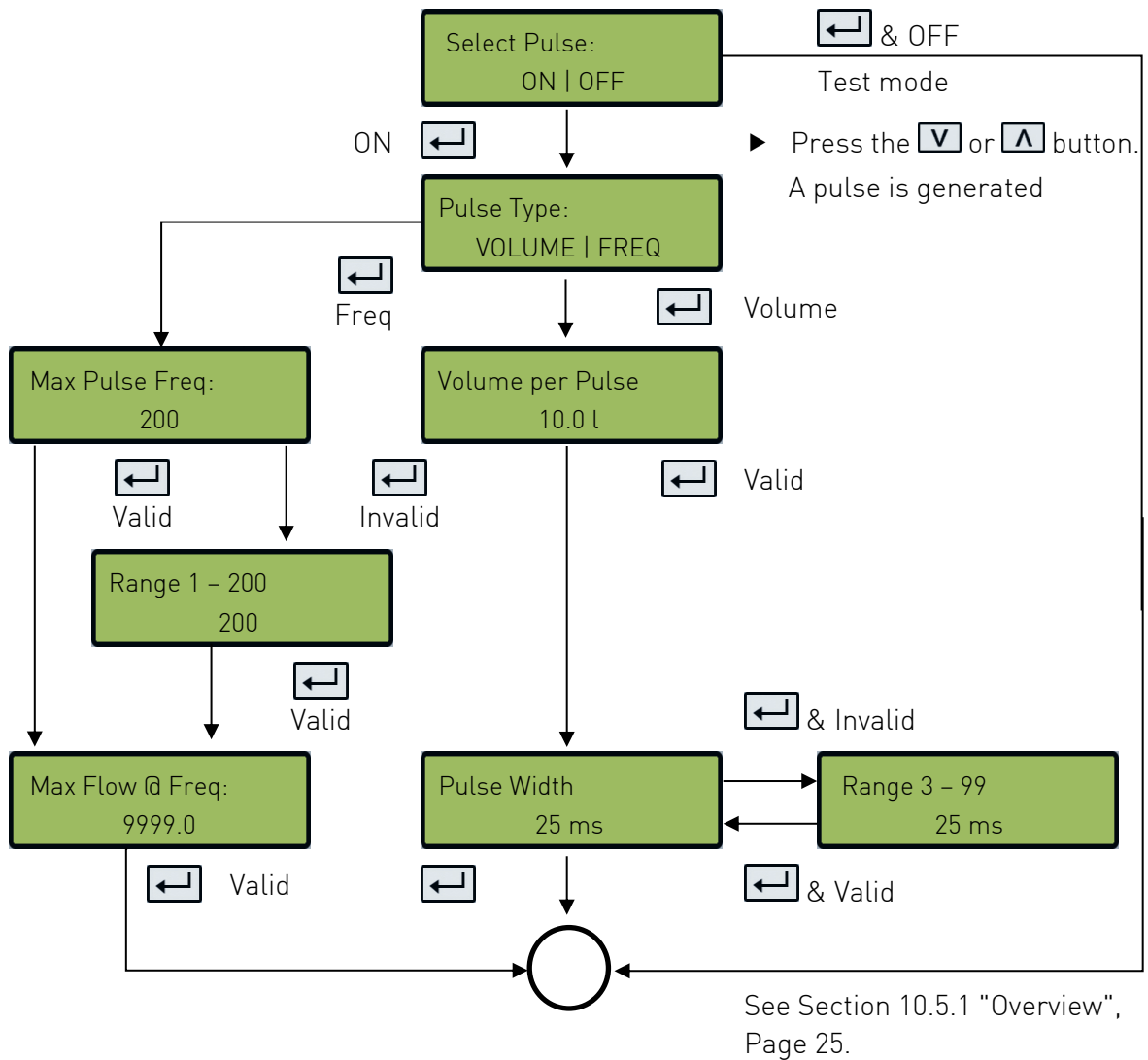

10.5.4 Current output

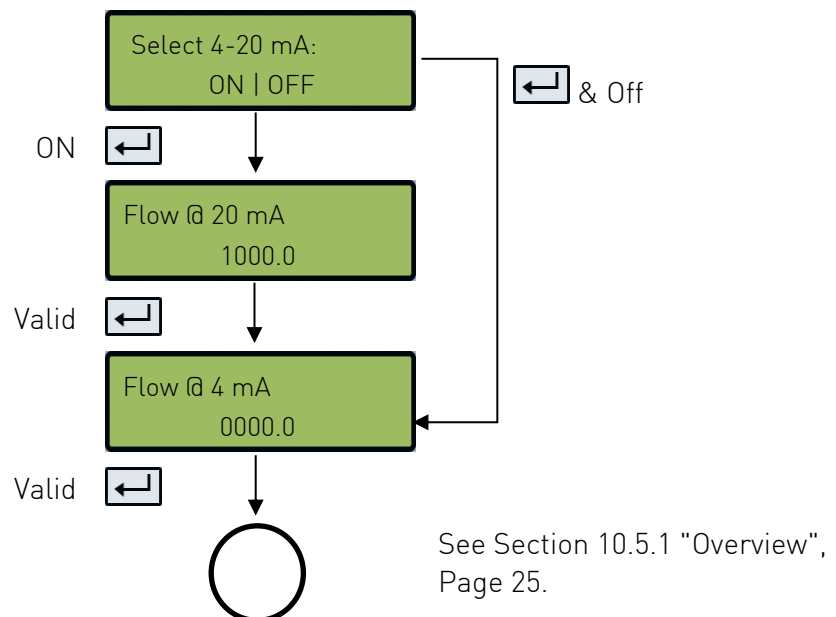

10.5.5 Calibration

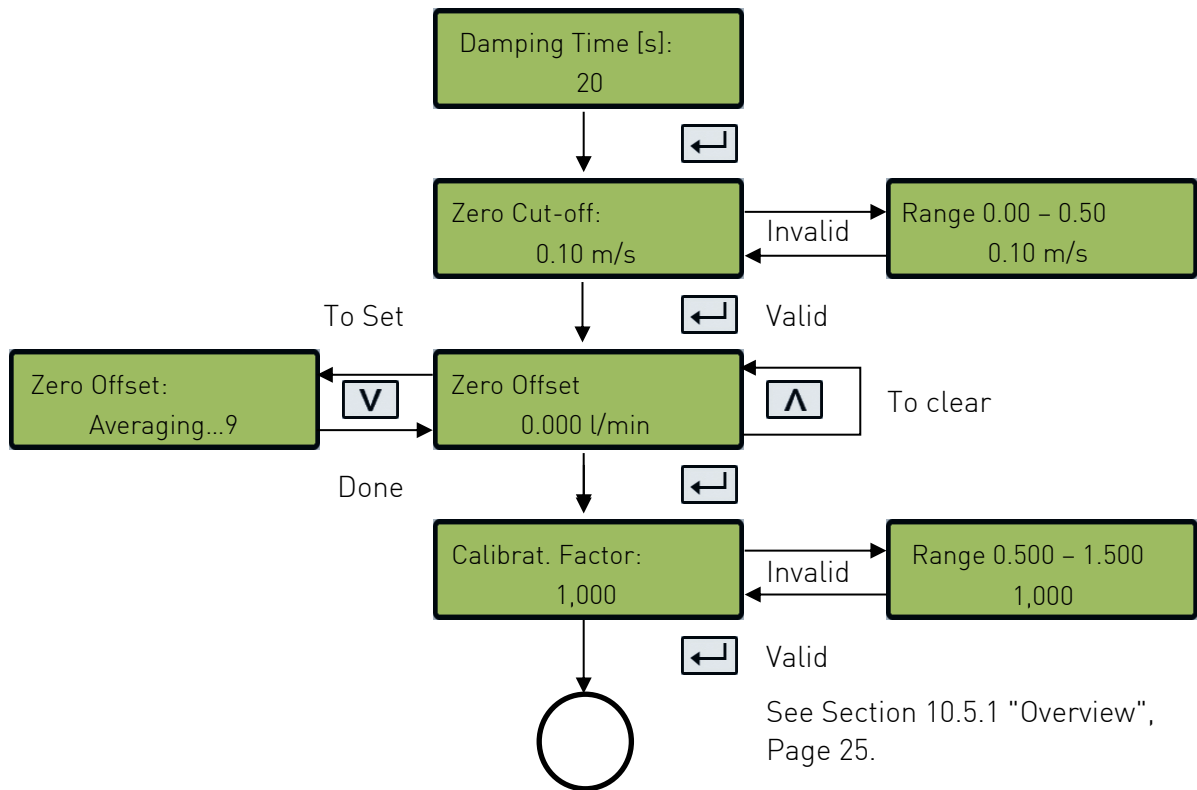

10.5.6 Total

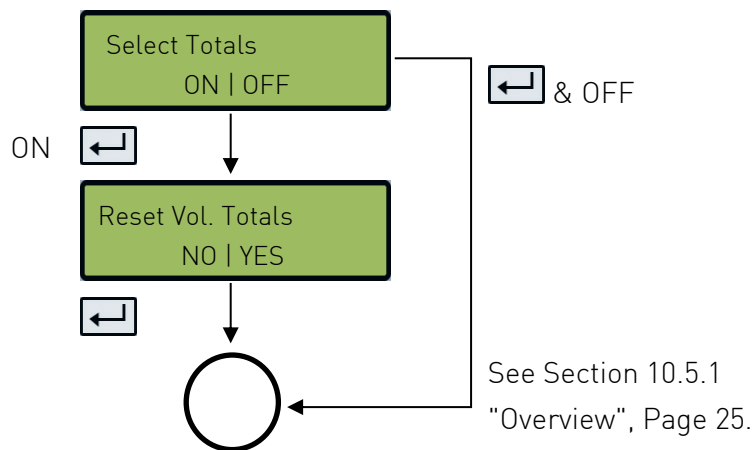

NOTICE

If the totalizer is activated, the display switches back and forth between the flow value and the total.

- ▶ Press the  button

Each screen is displayed for 30 s.

11 Diagnosis

NOTICE

The diagnosis menu provides additional information and various diagnosis options.

- ▶ In the diagnosis menu, the keypad is less responsive than in normal operating mode. The buttons therefore have to be pressed for a longer time.

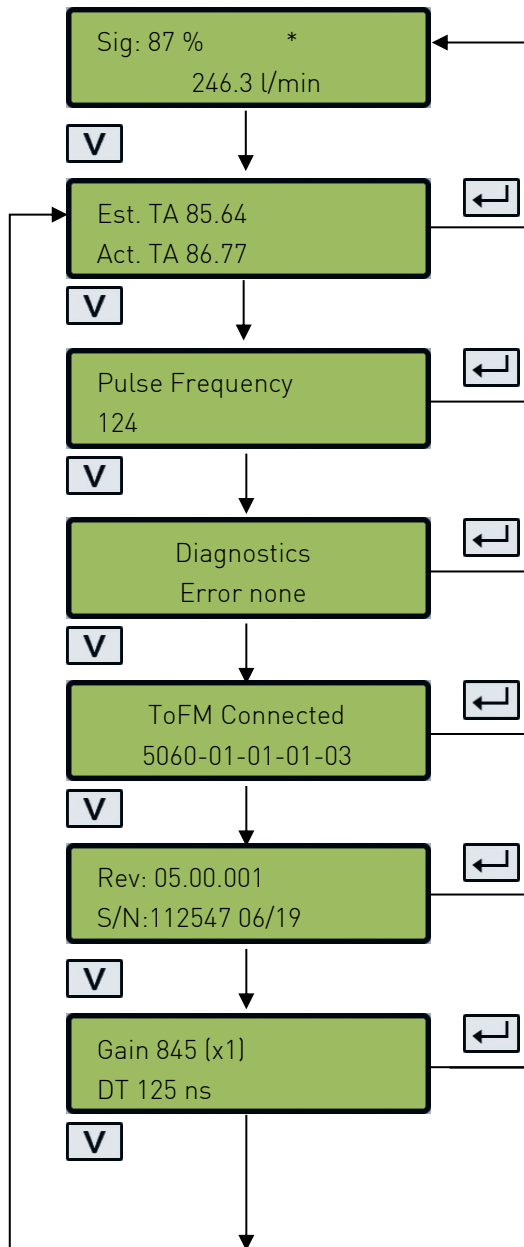

The estimated transmission time (Est. TA) and actual transmission time (Act. TA) are displayed. There should be a certain ratio between these two values.

If the frequency-based option (pulse frequency) is selected, the present pulse output frequency is displayed, proportional to the flow rate.

This screen will display the errors. A number between 0-255 will be displayed. If no errors reported "None" is displayed.

The flow board's software version is shown on the upper line. The lower line shows its status.

The software version (Rev.) and serial number (S/N) of the U1000 V2.

The gain factor is displayed as an indication of signal strength and switch setting. The values for a good signal 600 – 970 and switch setting (x1).

The current time difference (DT) between upstream and downstream signals in [1 ns = 10⁻⁹ s].

12 Maintenance

CAUTION

Risk of injury and loss of product quality through the use of spare parts not provided by GF Piping Systems!

Risk of injury and damage to property.

- ▶ If repairs are necessary, please contact your national agent for GF Piping Systems.

12.1 Maintenance plan

- ▶ Set the maintenance intervals according to the operating conditions (e.g. ambient temperature).
- ▶ Carry out the following maintenance tasks as part of the regular system inspection.

Maintenance interval	Maintenance task
6 – 12 months	▶ Renew the sound-conductive paste

For questions regarding maintenance of the product, please contact your national GF Piping Systems representative.

13 Troubleshooting

13.1 Flow errors and warnings

A signal strength of less than 40% indicates poor set up of the instrument, and the installation should be checked or possibly moved to a different site.

A negative flow is indicated by an "!" being displayed on the top line instead of a "**".

13.2 Error messages

Fault type	Error message	Cause and remedy
System error	Poor signal	The device is not receiving a signal from one or both transducers. ▶ If this message continues to be displayed, replace the sensors. See Section 8.6 Moving the guide rail, Page 16.
	Pulse overload	The Vol per pulse value is set too low. ▶ Increase this value in the password-protected menu, see Section 10 Password-protected menus , Page 23.

Fault type	Error message	Cause and remedy
	No BBME	This message indicates a device error. <ul style="list-style-type: none"> ▶ Switch the U1000 V2 off then on again. ▶ If this message continues to be displayed, please contact the GF Piping Systems Service department.
Error	Invalid password	An invalid password has been entered. <ul style="list-style-type: none"> ▶ Enter the correct password: 71360.
Warning messages	Range 20 – 110 mm 0.000 mm	An invalid pipe inside diameter has been entered. <ul style="list-style-type: none"> ▶ Enter a value within the indicated range.
	Range 0 – 99999 0000.0	The 4 - 20 mA current output is switched on and, in the password-protected area, an invalid value has been entered for the flow at maximum / minimum current. <ul style="list-style-type: none"> ▶ Enter a value within the indicated range.
	Range 1 – 200 200	An invalid frequency value has been entered for frequency-based pulse output. <ul style="list-style-type: none"> ▶ Enter a value within the indicated range.
	Range 3 – 99 00	An invalid pulse width value has been entered for volume-based pulse output. <ul style="list-style-type: none"> ▶ Enter a value within the indicated range.
	Range 0.000 – 0.500 0000.0	An invalid value has been entered for leak flow rate suppression . <ul style="list-style-type: none"> ▶ Enter a value within the indicated range.
	Range 0.5 – 1.5 0000.0	An invalid value has been entered for calibration factor . <ul style="list-style-type: none"> ▶ Enter a value within the indicated range.

Error messages are displayed as a number in the diagnostics menu. Contact GF Support if other messages appear.

Error meaning	Status Byte								Value
	Bit#7	Bit#6	Bit#5	Bit#4	Bit#3	Bit#2	Bit#1	Bit#0	
TOFM signal lost					1				8
TOFM board failed				1					16
TOFM windwo failed			1						32
TOFM sensor type failed		1							64
TOFM I2C failed	1								128

13.3 Modbus Error Messages

Test case	Transmitter							
	Address	Command	Start Register		Length (no of registers)		CRC-16	
	[1 byte]	[1 byte]	[2 bytes]		[2 bytes]		[2 bytes]	
No error	0x01	0x03	0x00	0x00	0x00	0x20	0x44	0x12
Incorrect function request	0x01	0x0C	0x00	0x00	0x00	0x20	0x10	0x13
incorrect register start	0x01	0x03	0x00	0xEF	0x00	0x20	0x75	0xE7
Incorrect register length	0x01	0x03	0x00	0x12	0xFF	0x02	0x25	0xFE
slave is busy	0x01	0x03	0x00	0x00	0x00	0x20	0x44	0x12
incorrect CRC-16	0x01	0x03	0x00	0x20	0x00	0x20	0x44	0xFF

Receiver				Comments		
Address	Command	Error code	CRC-16			
[1 byte]	[1 byte]	[1 byte]	[2 bytes]			
0x01	0x03	None	n/a	n/a	Example of a good message	
0x01	0x8C	0x01	0x85	0x00	The only acceptable commands are 0x03 and 0x06	
0x01	0x83	0x02	0xC0	0xF1	Incorrect register start	
0x01	0x83	0x03	0x01	0x31	Incorrect register length	
0x01	0x83	0x06	0xC1	0x32	slave is busy processing and is unable to respond	
0x01	0x83	0x07	0x00	0xF2	CRC is incorrect	

14 Removal

- ▶ Switch off the external power supply and prevent it from being switched on again.
- ▶ Disconnect all cable connections.
- ▶ Loosen the pipe clamps and remove the U1000 V2 completely from the pipe along with all connecting cables.

15 Disposal

- ▶ Before disposing of the different materials, separate them into recyclable materials, normal waste and special waste.
- ▶ Comply with local legal regulations and provisions when recycling or disposing of the product, individual components and packaging.
- ▶ Comply with national regulations, standards and directives.



A product marked with this symbol must be taken to a separate collection point for electrical and electronic devices.
 If you have any questions regarding disposal of the product, please contact your national agent for GF Piping Systems.

Worldwide at home

Our sales companies and representatives ensure local customer support in more than 100 countries.

www.gfps.com

Argentina / Southern South America

Georg Fischer Central Plastics Sudamérica S.R.L.
Buenos Aires / Argentina
Phone +54 11 4512 02 90
gfccentral.ps.ar@georgfischer.com
www.gfps.com/ar

Australia

George Fischer Pty Ltd
Riverwood NSW 2210
Phone +61 (0) 2 9502 8000
australia.ps@georgfischer.com
www.gfps.com/au

Austria

Georg Fischer Rohrleitungssysteme GmbH
3130 Herzogenburg
Phone +43 (0) 2782 856 43-0
austria.ps@georgfischer.com
www.gfps.com/at

Belgium / Luxembourg

Georg Fischer NV/SA
1600 Sint-Pieters-Leeuw / Belgium
Phone +32 (0) 2 556 40 20
Fax +32 (0) 2 524 34 26
be.ps@georgfischer.com
www.gfps.com/be

Brazil

Georg Fischer Sist. de Tub. Ltda.
04571-020 São Paulo/SP
Phone +55 (0) 11 5525 1311
br.ps@georgfischer.com
www.gfps.com/br

Canada

Georg Fischer Piping Systems Ltd
Mississauga, ON L5T 2B2
Phone +1 (905) 670 8005
Fax +1 (905) 670 8513
ca.ps@georgfischer.com
www.gfps.com/ca

China

Georg Fischer Piping Systems Ltd
Shanghai 201319
Phone +86 21 3899 3899
china.ps@georgfischer.com
www.gfps.com/cn

Denmark / Iceland

Georg Fischer A/S
2630 Taastrup / Denmark
Phone +45 (0) 70 22 19 75
info.dk.ps@georgfischer.com
www.gfps.com/dk

Finland

Georg Fischer AB
01510 Vantaa
Phone +358 (0) 9 586 58 25
Fax +358 (0) 9 586 58 29
info.fi.ps@georgfischer.com
www.gfps.com/fi

France

Georg Fischer SAS
95932 Roissy Charles de Gaulle Cedex
Phone +33 (0) 1 41 84 68 84
fr.ps@georgfischer.com
www.gfps.com/fr

Germany

Georg Fischer GmbH
73095 Albershausen
Phone +49 (0) 7161 302 0
info.de.ps@georgfischer.com
www.gfps.com/de

India

Georg Fischer Piping Systems Pvt. Ltd
400 083 Mumbai
Phone +91 22 4007 2000
Fax +91 22 4007 2020
branchoffice@georgfischer.com
www.gfps.com/in

Indonesia

PT Georg Fischer Indonesia
Karawang 41371, Jawa Barat
Phone +62 267 432 044
Fax +62 267 431 857
indonesia.ps@georgfischer.com
www.gfps.com/id

Italy

Georg Fischer S.p.A.
20063 Cernusco S/N (MI)
Phone +39 02 921 861
it.ps@georgfischer.com
www.gfps.com/it

Japan

Georg Fischer Ltd
530-0003 Osaka
Phone +81 (0) 6 6341 2451
jp.ps@georgfischer.com
www.gfps.com/jp

Korea

Georg Fischer Korea Co. Ltd
Unit 2501, U-Tower
120 Heungdeok Jungang-ro
(Yeongdeok-dong)
Giheung-gu, Yongin-si, Gyeonggi-do
Phone +82 31 8017 1450
Fax +82 31 217 1454
kor.ps@georgfischer.com
www.gfps.com/kr

Malaysia

George Fischer (M) Sdn. Bhd.
41200 Klang, Selangor Darul Ehsan
Phone +60 (0) 3 3122 5585
Fax +60 (0) 3 3122 5575
my.ps@georgfischer.com
www.gfps.com/my

Mexico / Northern Latin America

Georg Fischer S.A. de C.V.
CP 66636 Apodaca, Nuevo Leon / Mexico
Phone +52 (81) 1340 8586
Fax +52 (81) 1522 8906
mx.ps@georgfischer.com
www.gfps.com/mx

Middle East

Georg Fischer Piping Systems (Switzerland) Ltd
Dubai / United Arab Emirates
Phone +971 4 289 49 60
gcc.ps@georgfischer.com
www.gfps.com/int

Netherlands

Georg Fischer N.V.
8161 PA Epe
Phone +31 (0) 578 678 222
nl.ps@georgfischer.com
www.gfps.com/nl

New Zealand

Georg Fischer Ltd
5018 Upper Hutt
Phone +04 527 9813
Fax +04 527 9834
nz.ps@georgfischer.com
www.gfps.com/nz

Norway

Georg Fischer AS
1351 Rud
Phone +47 67 18 29 00
no.ps@georgfischer.com
www.gfps.com/no

Philippines

Georg Fischer Pte Ltd
Representative Office
1604 Pasig City
Phone +632 571 2365
Fax +632 571 2368
sgp.ps@georgfischer.com
www.gfps.com/sg

Poland

Georg Fischer Sp. z o.o.
05-090 Sekocin Nowy
Phone +48 (0) 22 31 31 0 50
poland.ps@georgfischer.com
www.gfps.com/pl

Romania

Georg Fischer Piping Systems (Switzerland) Ltd
020257 Bucharest - Sector 2
Phone +40 (0) 21 230 53 80
ro.ps@georgfischer.com
www.gfps.com/int

Russia

Georg Fischer Piping Systems (Switzerland) Ltd
Moscow 125040
Phone +7 495 748 11 44
ru.ps@georgfischer.com
www.gfps.com/ru

Singapore

George Fischer Pte Ltd
528 872 Singapore
Phone +65 6747 0611
Fax +65 6747 0577
sgp.ps@georgfischer.com
www.gfps.com/sg

Spain / Portugal

Georg Fischer S.A.
28046 Madrid / Spain
Phone +34 (0) 91 781 98 90
es.ps@georgfischer.com
www.gfps.com/es

Sweden

Georg Fischer AB
117 43 Stockholm
Phone +46 (0) 8 506 775 00
info.se.ps@georgfischer.com
www.gfps.com/se

Switzerland

Georg Fischer Rohrleitungssysteme (Schweiz) AG
8201 Schaffhausen
Phone +41 (0) 52 631 3026
ch.ps@georgfischer.com
www.gfps.com/ch

Taiwan

Georg Fischer Co. Ltd
San Chung Dist., New Taipei City
Phone +886 2 8512 2822
Fax +886 2 8512 2823
www.gfps.com/tw

United Kingdom / Ireland

Georg Fischer Sales Limited
Conventry, CV2 2ST / United Kingdom
Phone +44 (0) 2476 535 535
uk.ps@georgfischer.com
www.gfps.com/uk

USA / Caribbean

Georg Fischer LLC
92618 Irvine, CA / USA
Phone +1 714 731 8800
Fax +1 714 731 6201
us.ps@georgfischer.com
www.gfps.com/us

Vietnam

Georg Fischer Pte Ltd
Representative Office
Ho Chi Minh City
Phone +84 28 3948 4000
Fax +84 28 3948 4010
sgp.ps@georgfischer.com
www.gfps.com/vn

International

Georg Fischer Piping Systems (Switzerland) Ltd
8201 Schaffhausen / Switzerland
Phone +41 (0) 52 631 3003
Fax +41 (0) 52 631 2893
info.export@georgfischer.com
www.gfps.com/int

The information and technical data (altogether "Data") herein are not binding, unless explicitly confirmed in writing. The Data neither constitutes any expressed, implied or warranted characteristics, nor guaranteed properties or a guaranteed durability. All Data is subject to modification. The General Terms and Conditions of Sale of Georg Fischer Piping Systems apply.

