



3-2540.090 Rev. F 11/12 English

For the most up-to-date information, please refer to our website at www.gfsignet.com



SAFETY INSTRUCTIONS

1. Do not remove from pressurized lines.
2. Do not exceed maximum temperature/pressure specifications.
3. Wear safety goggles or faceshield during installation/service.
4. Do not alter product construction.
5. Apply sealant or PTFE tape to sensor threads, inspecting threads to ensure integrity. Do not install a sensor with damaged threads.



Pipe fittings **MUST** be installed by a certified welder only. Signet will not assume liability of any kind for improper fitting installations.



2540 Hot-Tap sensor specifications and limitations depend on the lowest maximum rating of the components associated with the system. For example, if a ball valve in the system is rated at a maximum 100 psi @ 175°F, you must limit the entire system's maximum pressure/temperature rating to 100 psi @ 175°F. All higher maximum specifications **MUST** yield to the component with the lowest maximum specification.



Maximum Operating Pressure/Temperature:

- 17 bar (250 psi) @ 82°C (180°F) with standard FPM sensor fitting O-rings.
- 17 bar (250 psi) @ 100°C (212°F) with optional EPDM sensor fitting O-rings.

Note: Pressure/temperature specifications refer to sensor performance in water. Certain chemical limitations may apply. Chemical compatibility should be verified.

1. Location of Fitting

Recommended sensor upstream/downstream mounting requirements.

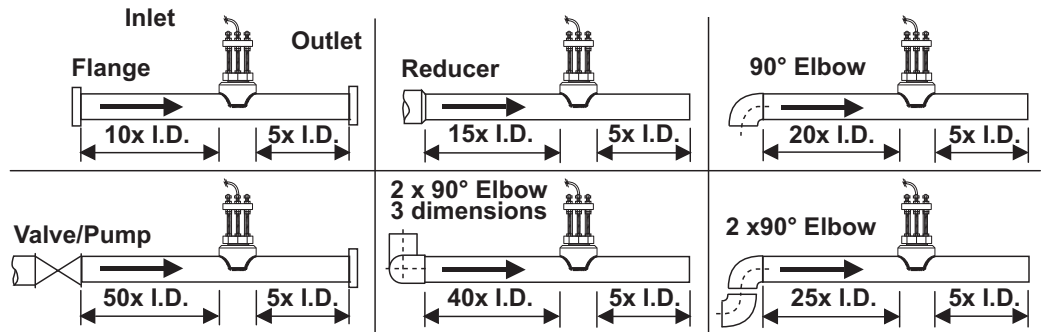

2. Sensor Mounting Position

Vertical mounting is recommended for best overall performance. Mount at a maximum of 30° when air bubbles are present. **DO NOT** mount on the bottom of the pipe when sediments are present.

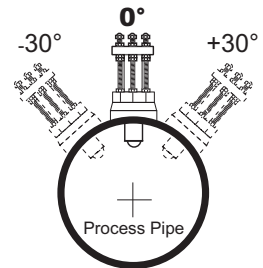

3. Sensor Wiring

Signet Instruments

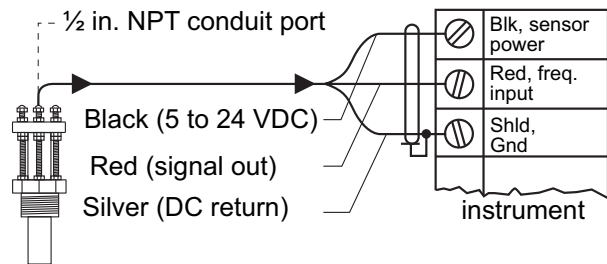

Other Brands

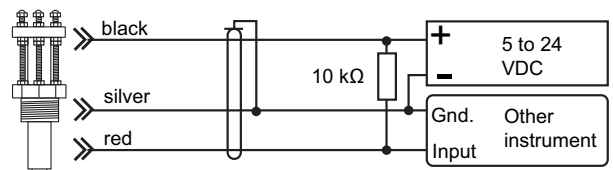

- pull-up resistor required (10 kΩ recommended).
- Use 2-conductor shielded cable for cable extensions up to 300m (1000 ft.)
- Maintain cable shield through splice.

- Use 2-conductor shielded cable for cable extensions up to 300m (1000 ft.)
- Maintain cable shield through splice.

4. Electronics Module Installation and Removal

The electronics module of this sensor can be replaced without removing the steel sensor body from the line.

1. Loosen liquid tight connector cap.
2. Loosen liquid tight connector compression fitting from sensor body.
3. Grasp the electronics at the rubber strain relief (do not pull on cable) and pull firmly.

To reinstall the electronics module:

- Insert module into sensor housing, making sure module is fully seated. The tip of the electronic module must bottom-out in the sensor housing.
- Replace the liquid tight connector assembly.

NOTE: Apply thread sealant to the liquid tight connector threads.

To install the cable inside protective conduit, remove the liquid tight connector completely. Thread ½ in. conduit into top of sensor body.

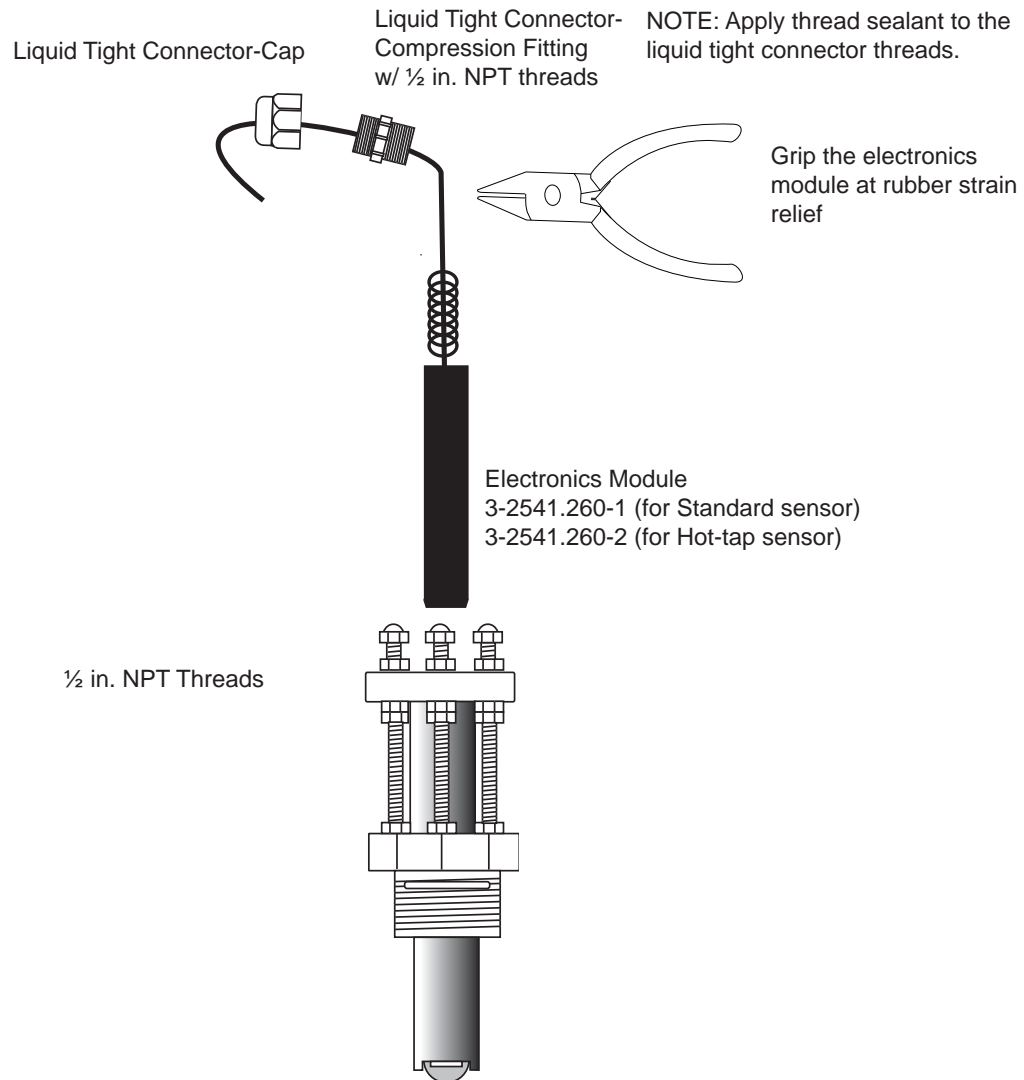

5. Installation

The following items are required to properly install Signet 2540 Sensors.

5.1 Hardware, Standard Sensor

- Female pipe fitting (weld-on or saddle) with 1½ in. NPT or ISO 7-Rc 1½ threads
- 32 mm (1¼ in.) diameter drill
- Pipe thread sealant
- Tape measure

5.2 Hardware, Hot-Tap Sensor

The Hot-Tap sensor requires all the standard sensor items plus:

- Hot-Tap drilling machine (e.g., Mueller drilling machine or equivalent)
- Female ball or gate valve (full port only) with 1½ in. NPT or ISO 7-Rc 1½ threads
- Male pipe nipple, 32 x 50 mm (1½ x 2 in.) with 1½ in. NPT or ISO 7-R 1½ threads
- Hot-Tap installation tool (purchased separately)

5.3 Standard Fitting Installation

- Depressurize and drain pipe.
- Wearing safety face protection, drill a 32 mm (1¼ in.) diameter hole in the pipe.
- Install the pipe fitting on the outside of the pipe according to the manufacturer's instructions. Failure to follow these instructions may result in serious bodily injury and/or product failure.
- Remove sensor fitting from sensor assembly.
- Thread sensor fitting into pipe fitting. (Fig. 1)

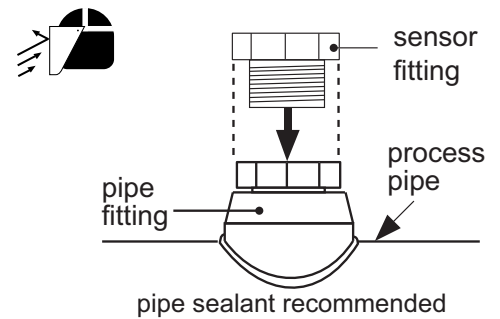

Fig. 1

5.4 Hot-Tap Fitting Installation

- Install the pipe fitting on the outside diameter of the pipe according to the manufacturer's instructions. Failure to follow these instructions may result in serious bodily injury and/or product failure.
- Install the pipe nipple and isolation valve (ball or gate valve) onto the external pipe fitting using pipe sealant on the threads. (Fig. 2)
- Wearing safety face protection, install an appropriate hole cutting tool per manufacturer's instructions (e.g., Mueller drilling machine) with a 32 mm (1.25 in.) drill onto the top of the isolation valve, ensuring a tight fit. **Use the recommended drill bit size or damage to the isolation valve may occur.**
- Open the isolation valve and insert the drill through the valve and cut the sensor clearance hole. After the hole is cut, withdraw the drill from the isolation valve and close the valve. Remove the drilling machine per manufacturer's instructions. (Fig. 3)
- Install the sensor fitting/bleed valve into the top of the isolation valve. Make sure the bleed valve clears the handle of the isolation valve during operation.

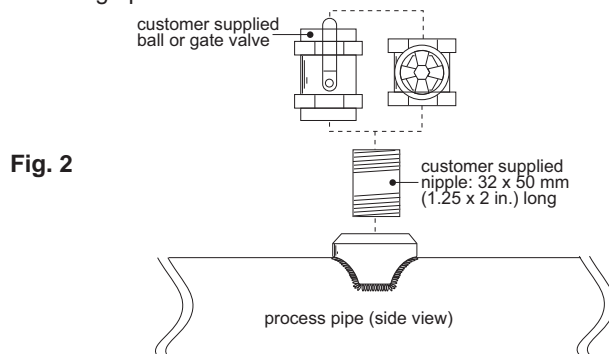

Fig. 2

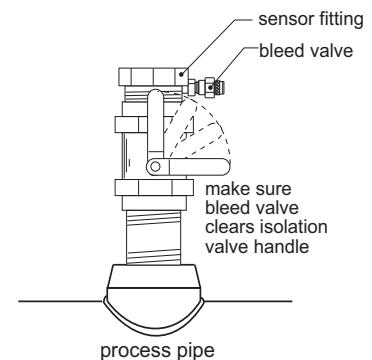

Fig. 3

5.5 Calculating the H Dimension

Before installing the sensor some critical dimensions must be established (for Hot-Tap installations, we assume the pipe dimensions are known). The rotor shaft must be located 10% inside the pipe I.D. to ensure accurate calibration capability. To accomplish this, the "H" dimension is measured from the outside surface of the pipe to the bottom of the sensor flange.

Nominal "H" dimensions for standard pipes are listed here. For non-standard pipe dimensions, calculate the "H" dimension using the formula listed below. The wall thickness and inside diameter (I.D.) are required for the "H" dimension calculation.

The 6 inch ruler (included) may be used to measure your pipe I.D. and wall thickness up to 5 inches (standard sensors only).

Pipe wall thickness: _____ Pipe I.D.: _____

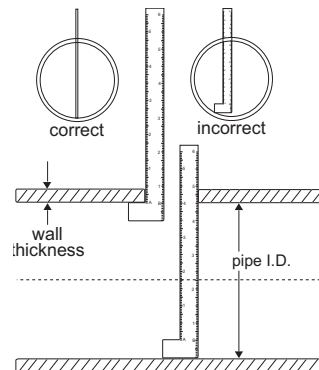

H Dimensions, Standard Sensors (2540-1, 2540-2)

(-----) unavailable

Wrought Steel Pipe Per ANSI 36.10

NPS inches	SCH 40 inches	SCH 80 inches	STD inches	XS inches
1½	4.924	4.880	4.924	4.880
2	4.869	4.818	4.869	4.818
2½	4.780	4.722	4.780	4.722
3	4.707	4.640	4.707	4.640
3½	4.649	4.576	4.649	4.576
4	4.590	4.510	4.590	4.510
5	4.467	4.374	4.467	4.374
6	4.344	4.222	4.344	4.222
8	4.110	3.968	4.110	3.968
10	3.863	3.680	3.863	3.755
12	3.630	3.405	3.655	3.555
14	3.480	3.230	3.530	3.430
16	3.230	2.955	3.330	3.230
18	2.980	2.680	3.130	3.030
20	2.755	2.405	2.930	2.830
22	-----	2.130	2.730	2.630
24	2.280	1.855	2.530	2.430

Stainless Steel Pipe Per ANSI B36.19

NPS inches	SCH 5S inches	SCH 10S inches	SCH 40S inches	SCH 80S inches
1½	4.988	4.953	4.924	4.880
2	4.940	4.905	4.869	4.818
2½	4.876	4.847	4.780	4.722
3	4.814	4.784	4.707	4.640
3½	4.764	4.734	4.649	4.576
4	4.714	4.684	4.590	4.510
5	4.586	4.567	4.467	4.374
6	4.480	4.460	4.344	4.222
8	4.280	4.249	4.110	3.968
10	4.048	4.023	3.863	3.755
12	3.830	3.811	3.655	3.555
14	3.705	3.680	-----	-----
16	3.498	3.480	-----	-----
18	3.298	3.280	-----	-----
20	3.080	3.056	-----	-----
22	2.880	2.856	-----	-----
24	2.656	2.630	-----	-----

H Dimensions, Hot-Tap Sensors (2540-3, 2540-4)

(-----) unavailable

Wrought Steel Pipe Per ANSI 36.10

NPS inches	SCH 40 inches	SCH 80 inches	STD inches	XS inches
1½	15.084	15.040	15.084	15.040
2	15.029	14.978	15.029	14.978
2½	14.940	14.882	14.940	14.882
3	14.867	14.800	14.867	14.800
3½	14.809	14.736	14.809	14.736
4	14.750	14.670	14.750	14.670
5	14.627	14.534	14.627	14.534
6	14.534	14.382	14.534	14.382
8	14.270	14.128	14.270	14.128
10	14.023	13.840	14.023	13.915
12	13.790	13.565	13.815	13.715
14	13.640	13.390	13.690	13.590
16	13.390	13.115	13.490	13.390
18	13.140	12.840	13.290	13.190
20	12.915	12.565	13.090	12.990
22	-----	12.290	12.890	12.790
24	12.440	12.015	12.690	12.590

Stainless Steel Pipe Per ANSI B36.19

NPS inches	SCH 5S inches	SCH 10S inches	SCH 40S inches	SCH 80S inches
1½	15.148	15.113	15.084	15.040
2	15.101	15.065	15.029	14.978
2½	15.036	15.007	14.940	14.882
3	14.974	14.944	14.867	14.800
3½	14.924	14.894	14.809	14.736
4	14.874	14.844	14.750	14.670
5	14.747	14.727	14.627	14.534
6	14.640	14.620	14.534	14.382
8	14.440	14.409	14.270	14.128
10	14.208	14.183	14.023	13.915
12	13.990	13.971	13.815	13.715
14	13.865	13.840	-----	-----
16	13.658	13.640	-----	-----
18	13.458	13.440	-----	-----
20	13.240	13.216	-----	-----
22	13.040	13.016	-----	-----
24	12.816	12.790	-----	-----

Standard Sensors: $H = 5.23 - \text{wall thickness} - (0.10 \times \text{I.D.})$

Hot-Tap Sensors: $H = 15.39 \text{ in.} - \text{wall thickness} - (0.10 \times \text{I.D.})$

Example: 3.0 inch schedule 80 wrought steel
Wall thickness = 0.3 in. / Inside diameter = 2.9 in.

$$H = 5.23 - 0.3 - (0.10 \times 2.9) / H = 117.86 \text{ mm (4.64 in.)}$$

Record your sensor's "H" dimension for future reference: $H =$ _____

After correct dimensions are calculated and recorded, the sensor can be installed in the fitting. The Standard and Hot-Tap versions require substantially different procedures.

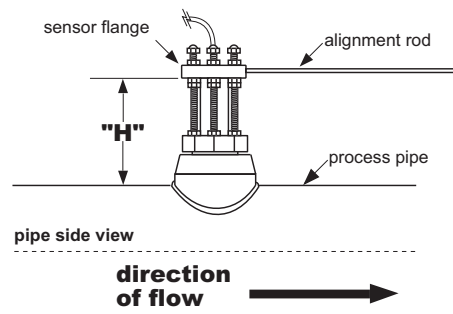

5.6 Standard Sensor Installation

- Thread one hex nut onto each of the three threaded rods included in package. Install threaded rod with a lock washer onto the sensor fitting. Secure rods in place by tightening each hex nut against the sensor fitting. (Fig. 4)
- Thread one jam nut and lower hex nut onto each threaded rod so that the top surface of each nut is at the proper "H" dimension for your pipe. Secure each hex nut with a jam nut. (Fig. 5)
- Insert the flow sensor into the sensor fitting, making sure the alignment hole on the sensor flange is pointing downstream. (Fig. 6)

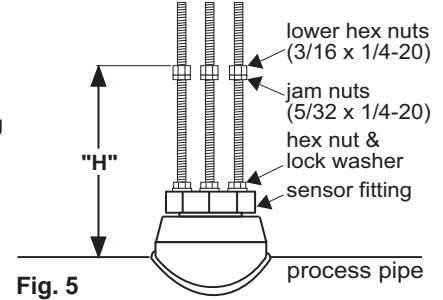
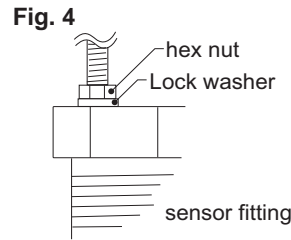

- Place the alignment rod in the alignment hole on the sensor flange. Align the flange so rod is parallel to the process pipe. (Fig. 6)
- Thread upper hex nuts with lock washers until they contact the sensor flange and tighten. Check for proper "H" dimension and readjust if necessary. (Fig. 7)

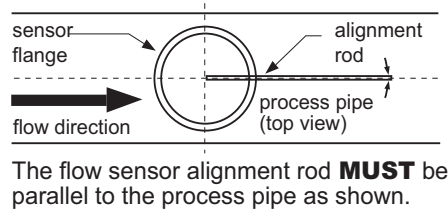

Fig. 6

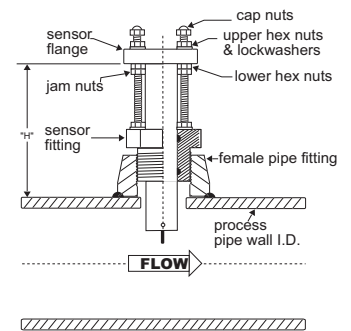

Fig. 7

5.7 Hot-Tap Sensor Installation

- Thread one hex nut onto each of the three threaded rods included in package. Install threaded rod with a lock washer onto the sensor fitting. Secure rods in place by tightening each hex nut against the sensor fitting. (Fig. 8)
- Thread one jam nut and lower hex nut onto each threaded rod so that the top surface of each nut is 359 mm (14.14 in.) from the top surface of the sensor fitting. Secure each hex nut with a jam nut. (Fig. 9)



CAUTION: This setting is critical to ensure an adequate sensor seal and to prevent the rotor from hitting the isolation valve orifice during installation.

- Wipe the sensor body with a dry, clean cloth. Orient the alignment hole on the sensor flange to point **downstream**. Place the slotted flange over the threaded rods. Lower the sensor into the fitting until the sensor flange rests on the lower hex and jam nuts. (Fig. 10 & Fig. 11)
- Secure the sensor with lock washers and upper hex nuts on the top of the flange. Before tightening, align the sensor flange so that the alignment rod is parallel and level with the process pipe. (Fig. 10 & Fig. 11)
- Make sure the bleed valve is closed (full clockwise position).

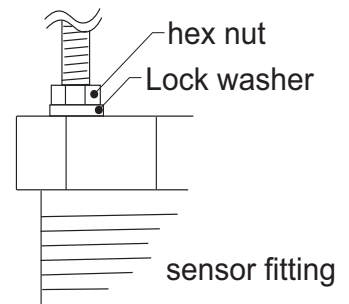

Fig. 8

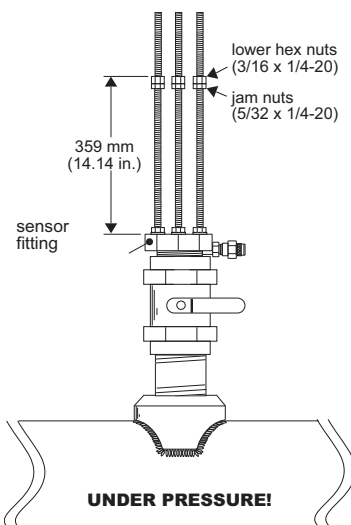

Fig. 9

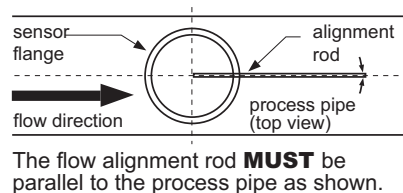

Fig. 10

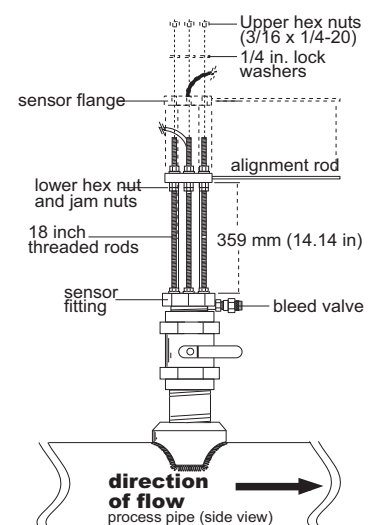

Fig. 11

Hot-Tap Sensor Installation - Continued

- F. Thread protector plate hex nuts onto each of the three threaded rods. Adjust each hex nut to a height of approximately 25 mm (1 in.) from the top of each rod. (Fig. 12)

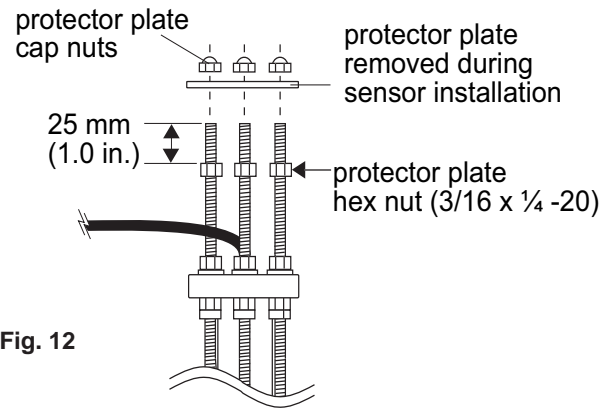
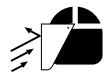

Fig. 12

- G. Position the installation tool bearing plate by rotating it so that it is approximately 40 mm (1.6 in.) from the swivel mount. Mount the installation tool by placing the threaded rods through the holes in the tool's bearing plate, resting the bearing plate on top of the protector plate hex nuts. Make sure the swivel mount's ears are mounted **between** the threaded rods (not over the rods). Install the bearing plate cap nuts. Tighten the bearing plate cap nuts to secure the installation tool in place. (Fig. 13)

- H. Align the sensor cable with the swivel mount cable port to prevent cable pinching. Use a 3/8 inch wrench or socket to turn the installation tool shaft clockwise until it is seated in the hole at the top of the sensor flange.

- I. Wearing safety face protection, **slowly open the isolation valve to the full open position**. Loosen the lower hex and jam nuts and move them to the proper "H" dimension. Turn the installation tool shaft **clockwise** until the sensor flange contacts the lower hex and jam nuts. Thread the upper hex nuts down until they contact the sensor flange. Tighten the upper hex nuts to secure the sensor. (Fig. 14)



- J. Remove cap nuts and withdraw the installation tool. Be careful to not damage cable. Replace protector plate and cap nuts. (Fig. 15)

Fig. 13

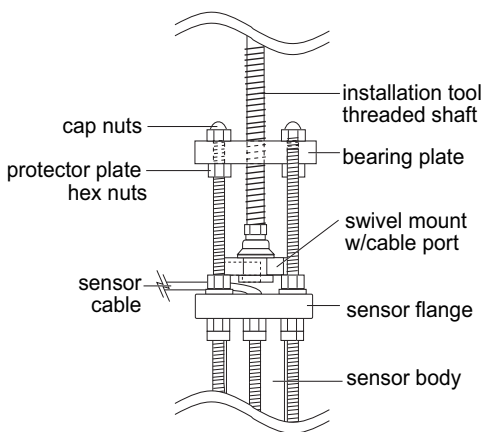

Fig. 14

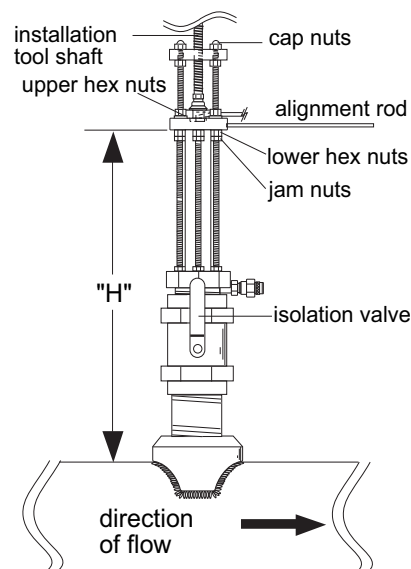
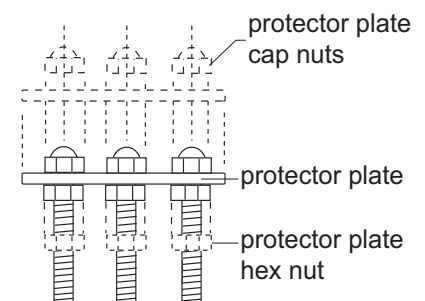

Fig. 15



6. Standard Sensor Removal

To remove the sensor from a **depressurized empty pipe**, simply remove the cap nuts and upper hex nuts located above the sensor flange. Pull up on sensor flange with twisting motion.

7. Hot-Tap Sensor Removal

To remove the Hot-Tap sensor safely from a pressurized active pipe, the entire installation process must be reversed.

- Remove the cap nuts, protector plate and protector plate hex nuts. (Fig. 16)
- Thread installation tool in place and secure bearing plate in place of sensor protector plate. (Fig. 17)
- Turn shaft of installation tool **clockwise** to lower tool into opening in sensor flange. Guide cable into the port to prevent damage.

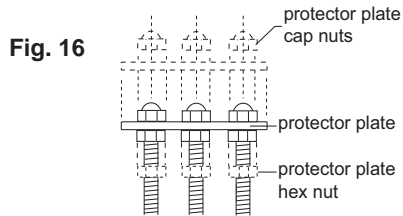

Fig. 16

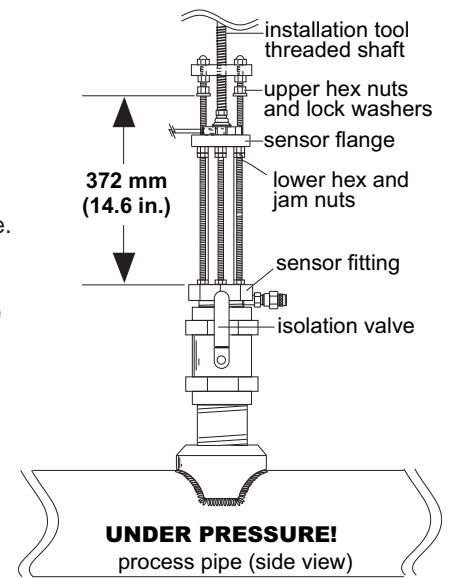
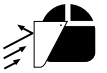

Fig. 17

- Wearing safety face protection, loosen the upper hex nuts and raise to 372 mm (14.6 in.) from top of sensor fitting to bottom of upper hex nuts/lock washers. **CAUTION! This measurement is critical to maintain watertight seal in sensor while allowing clearance to close the isolation valve.**



- Wearing safety face protection, turn the installation tool shaft **counterclockwise** to withdraw sensor until the sensor flange contacts the upper hex nuts. (Fig. 18)



- Raise **one** lower hex and jam nut to bottom of sensor flange.

- Close isolation valve, remove bearing plate and tool.

- Wearing safety face protection, cover the bleed valve with suitable protection (rag, towel, etc.) and open the bleed valve (ccw rotation) to relieve internal pressure. Pull sensor up until bleed valve purges some fluid (indicating sensor is past 1st o-ring seal inside sensor fitting).

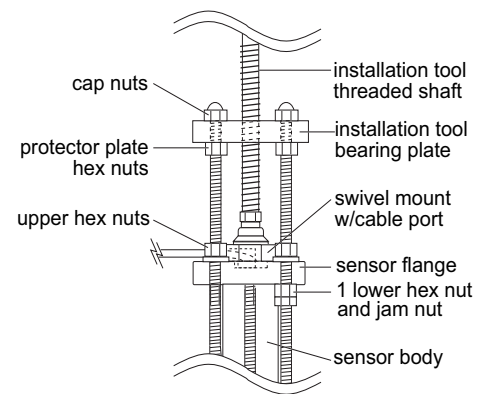

Fig. 18

CAUTION: In case of a leaky isolation valve, the sensor will be under a slight amount of pressure. Care should be taken when removing the sensor. Use the bleed valve to relieve this pressure taking care not to spray fluid on yourself or others.

Sensor can now be safely removed. When reinstalling the sensor: leave one lower hex nut in position to guide sensor to proper isolation valve clearance height before opening isolation valve. Return to "H" dimension height after valve is opened.

8. Maintenance

Your sensor requires little or no maintenance of any kind, with the exception of an occasional sensor/paddlewheel cleaning.

Rotor Replacement Procedure

- With a small pair of needle-nose pliers, firmly grip the center of the rotor pin (axle) and with a twisting motion, bend the rotor pin into an "S" shape. This should pull the ends of the pin out of the retainers and free the rotor assembly.

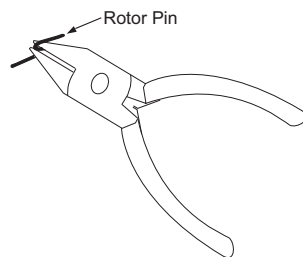

- Remove retainer from each side by gently tapping it inwards using a punch. Install a new retainer with its rotor pin clearance hole inward. Only install one retainer at this time.

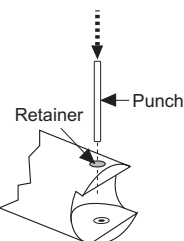

- Insert the new rotor assembly and bearings into the rotor housing of the sensor and place the new rotor pin (axle) through the open end of the rotor housing, through the rotor and bearings, and into the previously installed retainer.

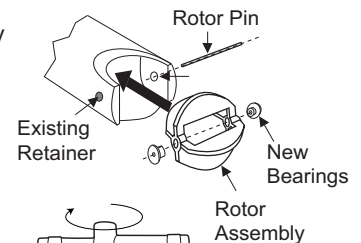

- Using a vise or C-clamp, press the second retainer into the hole in the sensor body while lining up the rotor pin with the center of the retainer hole.

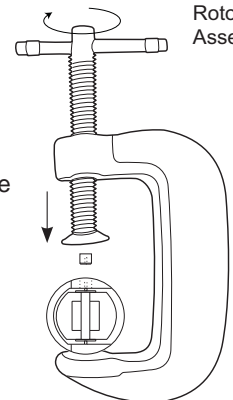

Note: A hammer and center punch can also be used if a clamp or vise is not available.

9. K-Factors (Stainless Steel, Wrought Steel & Plastic Pipe)

SCH 5S STAINLESS STEEL PIPE PER ANSI B36.19

PIPE SIZE	K-Factor PULSES/ U.S. GAL	K-Factor PULSES/ LITER
1½ in.	115.1900	30.433
2 in.	71.3960	18.863
2 ½ in.	49.263	13.015
3 in.	32.636	8.622
3 ½ in.	24.537	6.483
4 in.	19.1350	5.055
5 in.	12.4490	3.289
6 in.	8.4602	2.235
8 in.	4.9137	1.298
10 in.	3.1228	0.825
12 in.	2.1772	0.575
14 in.	1.7977	0.475
16 in.	1.3717	0.362
18 in.	1.0855	0.287
20 in.	0.8801	0.233
22 in.	0.7293	0.193
24 in.	0.6141	0.162

XS WROUGHT STEEL PIPE PER ANSI B36.10

PIPE SIZE	K-Factor PULSES/ U.S. GAL	K-Factor PULSES/ LITER
1 ½ in.	161.79	42.745
2 in.	95.713	25.287
2 ½ in.	66.686	17.618
3 in.	42.986	11.357
3 ½ in.	31.983	8.450
4 in.	24.668	6.517
5 in.	15.480	4.090
6 in.	10.691	2.825
8 in.	5.9733	1.578
10 in.	3.6489	0.964
12 in.	2.4548	0.649
14 in.	1.9931	0.527
16 in.	1.4970	0.396
18 in.	1.1727	0.310
20 in.	0.9388	0.248
22 in.	0.7685	0.203
24 in.	0.6446	0.170

SCH 40S STAINLESS STEEL PIPE PER ANSI B36.19

PIPE SIZE	K-Factor PULSES/ U.S. GAL	K-Factor PULSES/ LITER
1 ½ in.	140.030	36.996
2 in.	83.240	21.992
2 ½ in.	59.034	15.597
3 in.	38.675	10.218
3 ½ in.	28.752	7.596
4 in.	22.226	5.872
5 in.	14.061	3.715
6 in.	9.5160	2.514
8 in.	5.4523	1.441
10 in.	3.4507	0.912
12 in.	2.3318	0.616

SCH 40 STAINLESS STEEL PIPE

14 in.	1.9556	0.517
16 in.	1.4970	0.396
18 in.	1.1900	0.314
20 in.	0.9577	0.253
24 in.	0.6662	0.176

SCH 10S STAINLESS STEEL PIPE PER ANSI B36.19

PIPE SIZE	K-Factor PULSES/ U.S. GAL	K-Factor PULSES/ LITER
1½ in.	127.930	33.799
2 in.	76.439	20.195
2 ½ in.	51.946	13.724
3 in.	34.174	9.029
3½ in.	25.571	6.756
4 in.	19.829	5.239
5 in.	12.730	3.363
6 in.	8.5938	2.270
8 in.	5.0062	1.323
10 in.	3.1793	0.840
12 in.	2.1914	0.579
14 in.	1.8147	0.479
16 in.	1.3798	0.365
18 in.	1.0912	0.288
20 in.	0.8855	0.234
22 in.	0.7334	0.194
24 in.	0.6175	0.163

STD WROUGHT STEEL PIPE PER ANSI B36.10

PIPE SIZE	K-Factor PULSES/ U.S. GAL	K-Factor PULSES/ LITER
1 ½ in.	140.030	36.996
2 in.	83.240	21.992
2 ½ in.	59.034	15.597
3 in.	38.674	10.218
3 ½ in.	28.752	7.596
4 in.	22.226	5.872
5 in.	14.061	3.715
6 in.	9.5160	2.514
8 in.	5.4523	1.441
10 in.	3.4507	0.912
12 in.	2.3318	0.616
14 in.	1.9186	0.507
16 in.	1.4483	0.383
18 in.	1.1390	0.301
20 in.	0.9146	0.242
22 in.	0.7506	0.198
24 in.	0.6311	0.167

SCH 40 WROUGHT STEEL PIPE PER ANSI B36.10

PIPE SIZE	K-Factor PULSES/ U.S. GAL	K-Factor PULSES/ LITER
1 ½ in.	140.030	36.996
2 in.	83.240	21.992
2- ½ in.	59.034	15.597
3 in.	38.674	10.218
3 ½ in.	28.752	7.596
4 in.	22.226	5.872
5 in.	14.061	3.715
6 in.	9.5160	2.514
8 in.	5.4523	1.441
10 in.	3.4507	0.912
12 in.	2.3517	0.621
14 in.	1.9556	0.517
16 in.	1.4970	0.396
18 in.	1.1900	0.314
20 in.	0.9577	0.253
24 in.	0.6662	0.176

K-factors are listed in U.S. gallons and in liters. Conversion formulas for other engineering units are listed below.

- **K = 60/A**

The K-factor is the number of pulses generated by the 2540 paddlewheel per unit of liquid in a specific pipe size.

To convert K from:	to:	multiply K by:
U.S. gallons	cubic feet	7.479
U.S. gallons	cubic inches	0.00433
U.S. gallons	cubic meters	263.85
U.S. gallons	pounds of water	0.120
U.S. gallons	acre feet	325853
U.S. gallons	Imperial gallons	1.201

K-Factors (Stainless Steel, Wrought Steel & Plastic Pipe) continued

SCH 80S STAINLESS STEEL PIPE PER ANSI B36.19

PIPE SIZE	K-Factor PULSES/ U.S. GAL	K-Factor PULSES/ LITER
1 ½ in.	161.790	42.745
2 in.	95.710	25.287
2 ½ in.	66.686	17.618
3 in.	42.986	11.357
3 ½ in.	31.983	8.450
4 in.	24.668	6.517
5 in.	15.480	4.090
6 in.	10.691	2.825
8 in.	5.9733	1.578
10 in.	3.6489	0.964
12 in.	2.4548	0.649

SCH 80 STAINLESS STEEL PIPE

14 in.	2.1557	0.570
16 in.	1.6444	0.434
18 in.	1.3036	0.344
20 in.	1.0533	0.278
22 in.	0.8689	0.230
24 in.	0.7335	0.194

SCH 80 WROUGHT STEEL PIPE PER ANSI B36.10

PIPE SIZE	K-Factor PULSES/ U.S. GAL	K-Factor PULSES/ LITER
1 ½ in.	161.790	42.745
2 in.	95.713	25.287
2 ½ in.	66.686	17.618
3 in.	42.986	11.357
3 ½ in.	31.983	8.450
4 in.	24.668	6.517
5 in.	15.480	4.090
6 in.	10.691	2.825
8 in.	5.9733	1.578
10 in.	3.7983	1.004
12 in.	2.6198	0.692
14 in.	2.1557	0.570
16 in.	1.6444	0.434
18 in.	1.3036	0.344
20 in.	1.0533	0.278
22 in.	0.8689	0.230
24 in.	0.7335	0.194

SCH 40 Plastic pipe per ASTM-D-1785

PIPE SIZE	K-Factor PULSES/ U.S. GAL	K-Factor PULSES/ LITER
1 ½ in.	139.850	36.948
2 in.	82.968	21.920
2 ½ in.	60.194	15.903
3 in.	39.513	10.439
3 ½ in.	29.295	7.740
4 in.	22.565	5.962
5 in.	14.308	3.780
6 in.	9.8630	2.606
8 in.	5.6400	1.490
10 in.	3.4476	0.911
12 in.	2.3786	0.628

SCH 80 Plastic pipe per ASTM-D-1785

PIPE SIZE	K-Factor PULSES/ U.S. GAL	K-Factor PULSES/ LITER
1 ½ in.	162.290	42.877
2 in.	97.186	25.677
2 ½ in.	68.559	18.113
3 in.	43.870	11.590
3 ½ in.	32.831	8.674
4 in.	25.250	6.671
5 in.	15.835	4.184
6 in.	11.041	2.917
8 in.	6.2877	1.661
10 in.	3.8529	1.018
12 in.	2.6407	0.698

10. Specifications

General Data

Flow velocity range:	0.1 to 6 m/s (0.3 to 20 ft/s)
Linearity:	±1% of full range
Repeatability:	±0.5% of full range
Pipe range:	
• Standard version:	38 to 610 mm (1.5 to 24 in.)
• Hot-Tap version:	38 to 914 mm (1.5 to 36 in.)
Sensor fitting options:	316 SS with 1.5 in. NPT threads, OR 316 SS with ISO 7-R 1½ threads
Cable length:	7.6 m (25 ft), can splice up to 300 m (1000 ft)
Cable type:	2-conductor twisted-pair with 22 AWG shield

Electrical Data

Supply voltage:	5 to 24 VDC
Supply current:	1.5 mA max.
Output type:	Open collector, sinking
Output current:	10.0 mA max.

Wetted Materials

Sensor body:	316 stainless steel
Sensor fitting:	316 stainless steel
Sensor fitting O-rings:	Standard FPM, optional EPDM
Rotor:	CB7 Cu-1 alloy 17-4 per AMS5355H
Rotor shaft:	Tungsten carbide (standard) 316 stainless steel (option)
Shaft retainers (2):	316 stainless steel
Rotor bearings (2):	Carbon fiber reinforced PTFE

Quality Standards

- Manufactured under ISO 9001 for Quality, ISO 14001 for Environmental Management and OHSAS 18001 for Occupational Health and Safety.

 China RoHS (Go to www.gfsignet.com for details)

 **This device complies with Part 15 of the FCC rules**

Operation is subject to the following two conditions:

- (1) This device may not cause harmful interference, and,
- (2) This device must accept any interference received, including interference that may cause undesired operation.

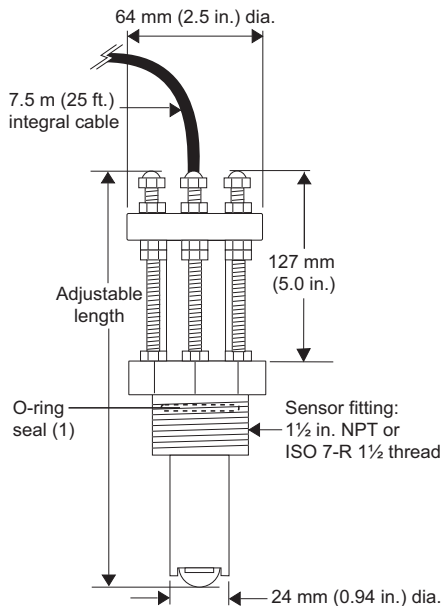

Standard Sensor Dimensions:

- 2540-1(S) = 1½ in. NPT fitting
- 2540-2(S) = ISO 7-R 1½ fitting

Fluid Conditions

Maximum operating pressure/temperature:

- Sensor with standard FPM sensor fitting O-rings:
17 bar (250 psi) @ 82°C (180°F)
- Sensor with optional EPDM sensor fitting O-rings:
17 bar (250 psi) @ 100°C (212°F)

Note: Pressure/temperature specifications refer to sensor performance in water. Certain chemical limitations may apply. Chemical compatibility should be verified.

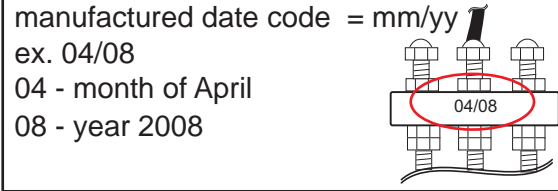

Caution: The 2540 Hot-Tap system's overall specifications and limitations depend on the lowest maximum rating of the components associated with the system. In other words, the Hot-Tap system is only as strong as its weakest link. For example, a ball valve, a component of the system, is rated at a maximum 100 psi @ 175°F, limiting the entire system's maximum pressure/temperature rating to 100 psi @ 175°F. All higher maximum specifications **MUST** yield to the component with the lowest maximum specification.

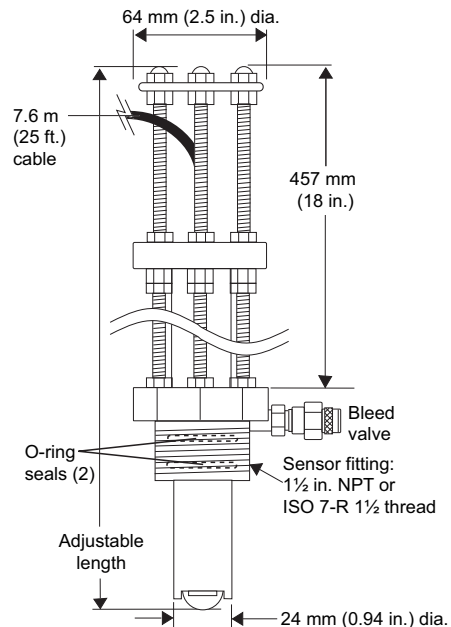

Hot-Tap Sensor Dimensions:

- 2540-3(S) = 1½ in. NPT fitting
- 2540-4(S) = ISO 7-R 1½ fitting

Notes:

11. Ordering Information

Sensor Part Number		
3-2540	Stainless Steel High Performance flow sensor with removable electronics	
↓	Mounting option - choose one	
	-1	1½ inch NPT thread
	-2	1½ inch ISO thread
	-3	1½ inch NPT thread, hot tap design*
	-4	1½ inch ISO thread, hot tap design*
	Rotor Pin Material	
↓	-	Tungsten Carbide
	-S	Stainless Steel
3-2540	-1	Example Part Number

*Must use 3-1500.663 Hot-Tap installation tool (ordered separately)

Mfr. Part No.	Code	Mfr. Part No.	Code
3-2540-1	198 840 035	3-2540-1S	159 001 501
3-2540-2	198 840 036	3-2540-2S	159 001 502
3-2540-3	198 840 037	3-2540-3S	159 001 503
3-2540-4	198 840 038	3-2540-4S	159 001 504

Accessories and Replacement Parts

Mfr. Part No.	Code	Description
3-1500.663	198 820 008	Hot-Tap Installation Tool
1220-0021	198 801 000	O-ring, FPM
1224-0021	198 820 006	O-ring, EPDM
1228-0021	198 820 007	O-ring, FPM
3-2540.321	159 000 623	Rotor Kit, 2540 Tungsten Carbide Pin
3-2540.322	159 000 864	Rotor kit, Stainless Steel pin
P52504-3	159 000 866	Rotor pin, Tungsten Carbide
P52504-4	159 000 867	Rotor pin, 316 SST
3-2540.520	159 000 648	Bearing, PTFE
P52527	159 000 481	Retainers, SS (1.4401)
3-2541.260-1	159 000 849	Standard replacement electronics module
3-2541.260-2	159 000 850	Hot-Tap replacement electronics module
5523-0222	159 000 392	Cable, per ft.
P51589	159 000 476	Conduit Adapter Kit
P31934	159 000 466	Conduit Cap



Georg Fischer Signet LLC, 3401 Aero Jet Avenue, El Monte, CA 91731-2882 U.S.A. • Tel. (626) 571-2770 • Fax (626) 573-2057
 For Worldwide Sales and Service, visit our website: www.gfsignet.com • Or call (in the U.S.): (800) 854-4090
 For the most up-to-date information, please refer to our website at www.gfsignet.com