

PARTS LIST		
QTY	PART NUMBER	DESCRIPTION
1	01-050-03-0001	STANDARD EXPANSION BOX: DOOR LATCH ADJUSTER
1	01-050-03-0002	EXPANSION CHAMBER - DOOR LATCH SUPPORT
1	01-050-36-0003	EXPANSION BOX LATCH FEMALE
1	01-054-07-0005	STANDARD EXPANSION BOX: LATCH SPACER FOR DOOR
2	ANSI B18.22.1 - No. 6 - narrow - Type B	Plain Washer (Inch)Type A and B
2	ANSI B18.3 - No. 6 - 32 UNC - 5/16 HS HCS	Hexagon Socket Head Cap Screw
4	ANSI B18.6.3 - 4-40 UNC x 0.5625	Cross Recessed Close Tolerance 100° Flat Countersunk Head Machine Screw - Type II - UNC - Inch
3	ANSI B18.22.1 - No. 8 - Type A	Plain Washer (Inch)Type A and B
3	ANSI B18.6.3 - No. 8 - 32 - 3/4	Cross Recessed Pan Head Machine Screw - Type II
1	01-450-36-0001	NIDEC GAMMA30 AIR BLOWER
1	MOLDED EXPANSION CHAMBER DOOR ASSEMBLY	01-054-00-0000 DOOR SUB ASSEMBLY
2	01-054-03-0003	STANDARD EXPANSION BOX: DOOR HINGE (LOOSE)
2	01-054-01-0009	DOOR LATCH WITH PIN
17	ANSI B18.6.3 - 4-40 UNC x 0.375	Cross Recessed 100° Flat Countersunk Head Machine Screw - Type II - UNC - Inch
12	ANSI B18.6.3 - 8-32 UNC x 0.5625	Cross Recessed 100° Flat Countersunk Head Machine Screw - Type II - UNC - Inch
2	01-054-03-0002	STANDARD EXPANSION BOX: HINGE COVER
3	01-200-51-0001	M2000 RUBBER FOOT 1-1/2" X 3/4"
1	01-054-02-0010	STANDARD EXPANTION CHAMBER: DOOR MOUNTING BRACKET
1	01-054-01-0011	CARBON FIBER CHAMBER SUB-ASSY
1	01-050-31-0001	4 PIN POWER CONNECTOR
1	01-020-36-0004	16A_ROCKER_SWITCH
1	01-450-36-0002	CHAMBER LIGHT BUTTON
4	ANSI B18.6.3 - 1/4 - 28 - 1 1/4	Cross Recessed Pan Head Machine Screw - Type II
4	01-050-36-0004	EXPANSION BOX NYLON WASHER

REVISION #1	DRAWN BY: jpruden
INITIALS:	APPROVED BY: KSM
SCALE: AS SHOWN	CREATION DATE: 2021-06-15
	COMPANY:

01-054-00-0000



FILE PATH:

C:\ENGINEERING\AMP_DS_PROJECTS\ACCESSORIES\EXPANSION_BOXES\EXTENSION_BOX_PARTS\01-054-00-0000(EXPANSION_BOX(STANDARD_MOLDED))_idw

The A.M.P. Design Solutions Inc. makes no representation or warranties, express or implied, with respect to the reuse of the data provided herewith, regardless of its format or the means of its transmission. There is no guarantee or representation to the user as to the accuracy, currency, suitability or reliability of this data for any purpose. The user accepts the data "as is", and assumes all risks associated with its use. By acceptance of this data, the user agrees not to transmit this data or provide access or any part of it to another party unless the user shall include with the data a copy of this disclaimer. The A.M.P. Design Solutions Inc. assumes no responsibility for actual or consequential damage incurred as a result of any user's reliance on this data.

8 7 6 5 4 3 2 1

4

4

3

3

2

2

1

1

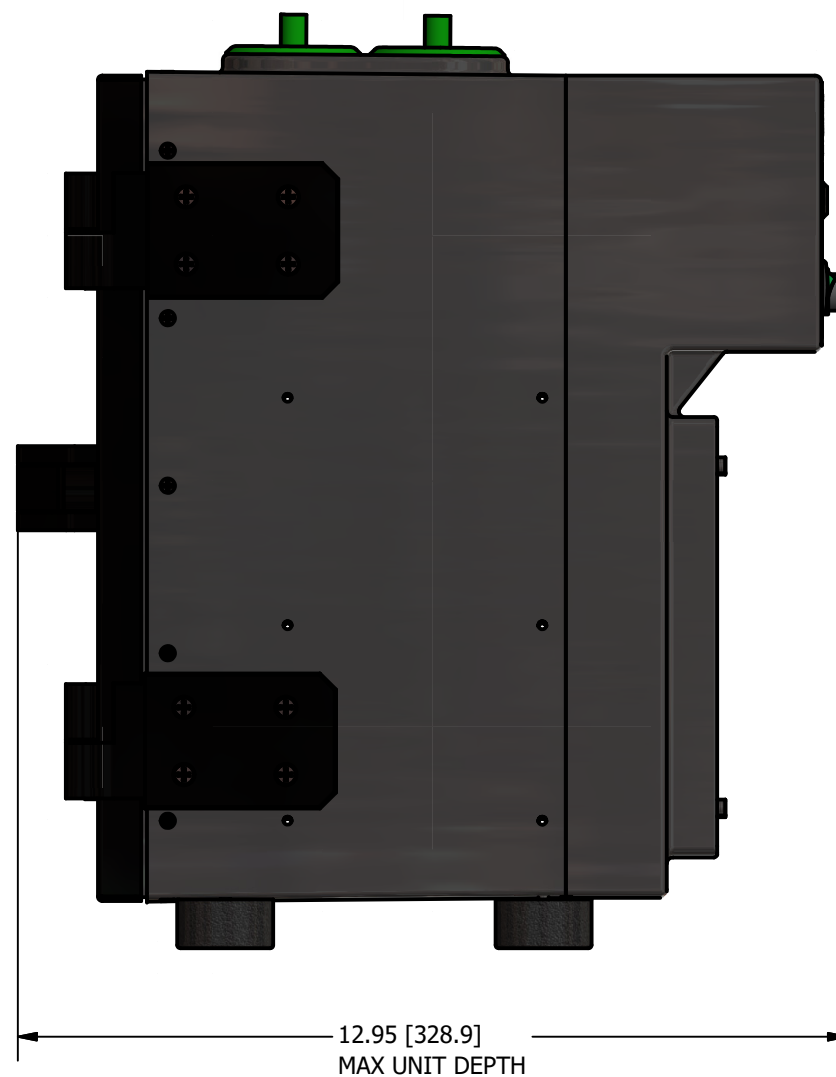
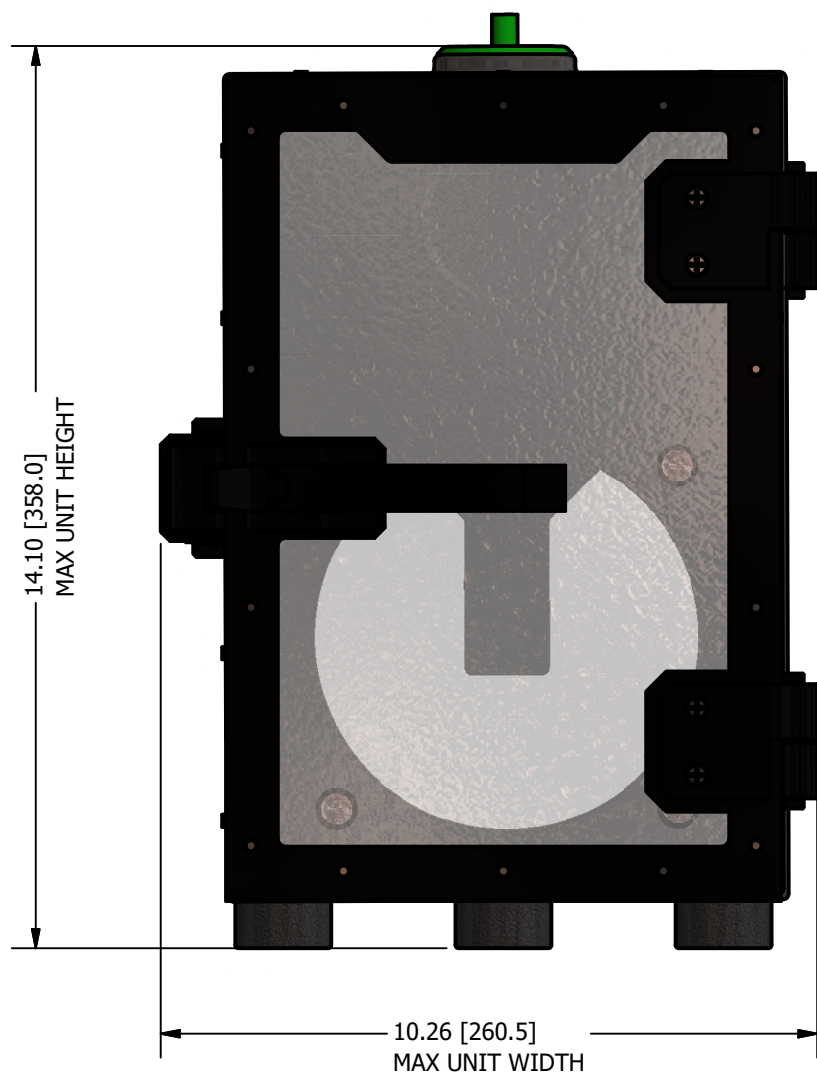

REVISION
#1

DRAWN BY:
jpruden

01-054-00-0000

SCALE:
AS SHOWN

INITIALS:

APPROVED BY:

KSM

CREATION DATE:

2021-06-15

COMPANY:



FILE PATH:

C:\ENGINEERING\CAMP_DS_PROJECTS\ACCESSORIES\EXPANSION_BOXES\EXTENSION_BOX_PARTS\01-054-00-0000(EXPANSION_BOX(STANDARD_MOLDED))_dwg

The A.M.P. Design Solutions Inc. makes no representation or warranties, express or implied, with respect to the reuse of the data provided herewith, regardless of its format or the means of its transmission. There is no guarantee or representation to the user as to the accuracy, currency, suitability or reliability of this data for any purpose. The user accepts the data "as is", and assumes all risks associated with its use. By acceptance of this data, the user agrees not to transmit this data or provide access or any part of it to another party unless the user shall include with the data a copy of this disclaimer. The A.M.P. Design Solutions Inc. assumes no responsibility for actual or consequential damage incurred as a result of any user's reliance on this data.

SHEET 30 OF 31

8 7 6 5 4 3 2 1

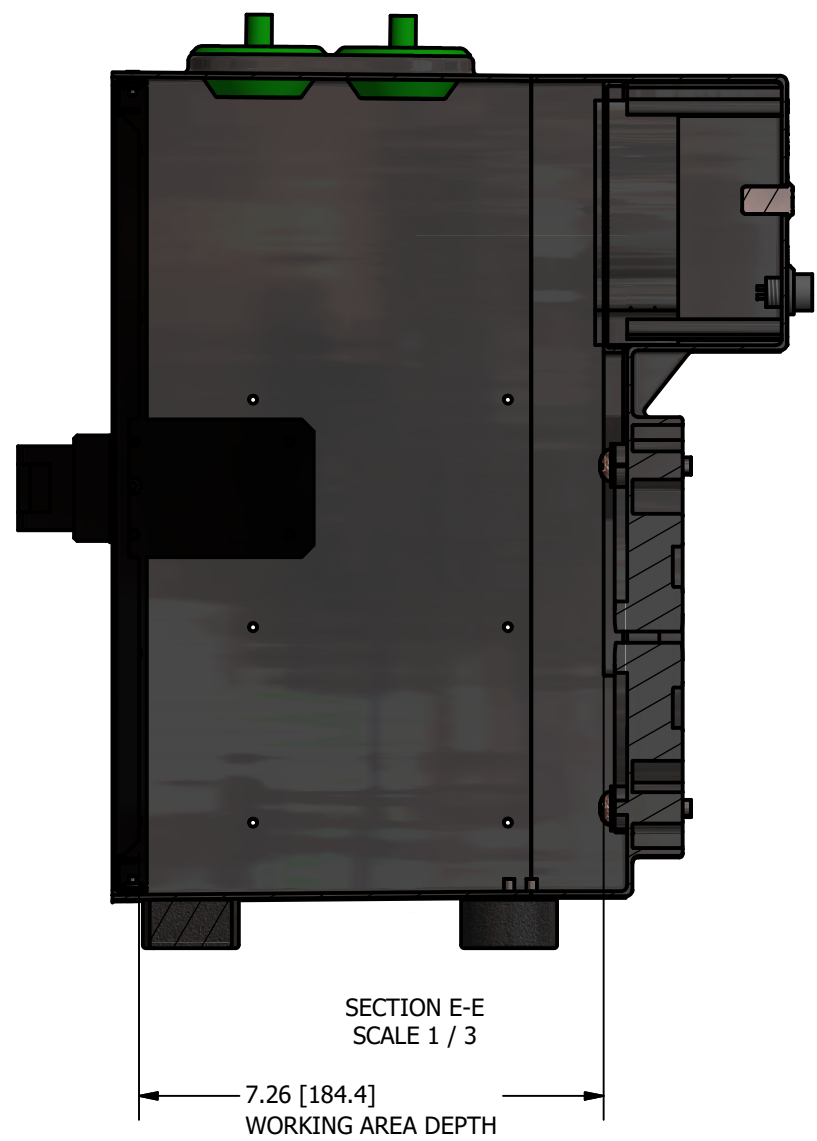
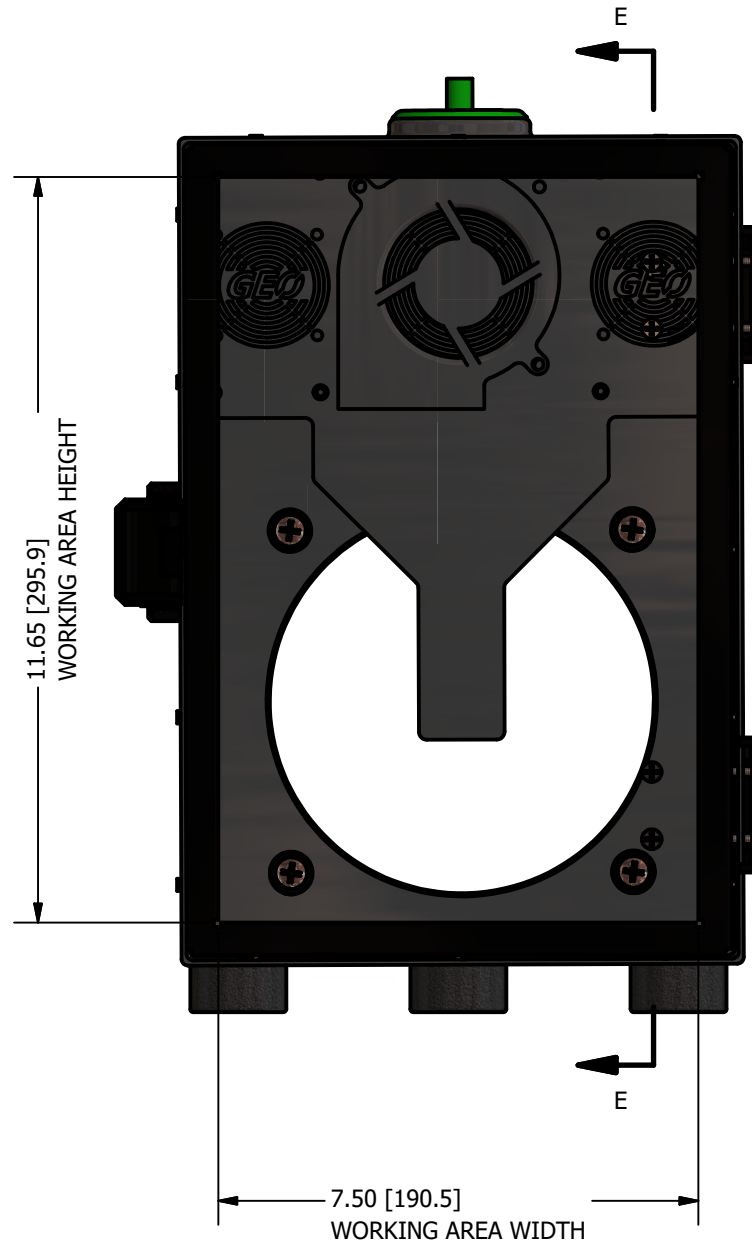

FILE PATH:

C:\ENGINEERING\CAMP_DS_PROJECTS\ACCESSORIES\EXPANSION_BOXES\EXTENSION_BOX_PARTS\01-054-00-0000(EXPANSION_BOX(STANDARD_MOLDED))_dwg

The A.M.P. Design Solutions Inc. makes no representation or warranties, express or implied, with respect to the reuse of the data provided herewith, regardless of its format or the means of its transmission. There is no guarantee or representation to the user as to the accuracy, currency, suitability or reliability of this data for any purpose. The user accepts the data "as is", and assumes all risks associated with its use. By acceptance of this data, the user agrees not to transmit this data or provide access or any part of it to another party unless the user shall include with the data a copy of this disclaimer. The A.M.P. Design Solutions Inc. assumes no responsibility for actual or consequential damage incurred as a result of any user's reliance on this data.

REVISION #1	DRAWN BY: jpruden
INITIALS:	APPROVED BY: KSM
SCALE: AS SHOWN	CREATION DATE: 2021-06-15
	COMPANY:

01-054-00-0000

