

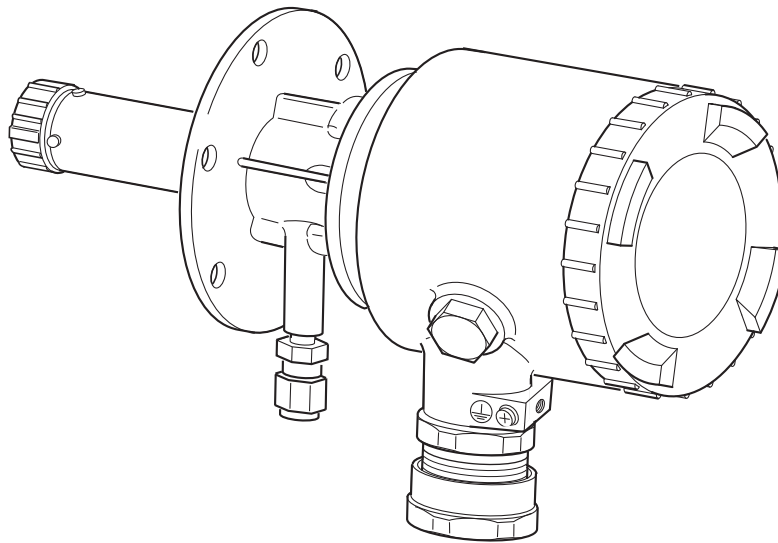

Instruction Manual

THE DIRECT INSERTION TYPE ZIRCONIA OXYGEN ANALYZER DETECTOR

TYPE: ZFK8



PREFACE

Thank you very much for your kind purchase of Fuji's zirconia oxygen analyzer detector (Type ZFK 8).

- Read this instruction manual carefully to get a thorough understanding of how this zirconia oxygen analyzer works prior to installing, operating and maintaining the zirconia oxygen analyzer.
If abused, unnecessary troubles or failure could occur.
- The specification of this zirconia oxygen analyzer may be subject to change without previous notice for improvements of the product.
- Under no circumstances should this zirconia oxygen analyzer be modified without permission.
If any trouble should occur because of having been modified without permission, we won't be responsible for it anyway.
- This instruction manual should be kept in custody by a person who operates the zirconia oxygen analyzer actually.
- After reading this manual, it should always be kept in a place which allows the person who operates it to refer to any time as required.
- A due consideration should be given so that this instruction manual is delivered to a final user certainly.

Manufacturer : Fuji Electric Co., Ltd.
Type : Described in the nameplate put on the main body
Date of manufacture : Described in the nameplate put on the main body
Product nationality : Japan

Related instruction manuals

Direct insertion type zirconia oxygen analyzer converter (Type : ZKM) INZ-TN1ZKM
Direct insertion type zirconia oxygen analyzer-use ejector (Type : ZTA) INZ-TN1ZTA

NOTE

- It is prohibited to transfer a part or all of the contents of this manual without permission.
- The contents of this manual may be subject to change in future without previous notice



© Fuji Electric Co., Ltd. 2008



Issued in Aug , 2008
Rev.1st edition Oct , 2008
Rev.2st edition Apr , 2009
Rev.3rd edition Apr , 2011

SAFETY PRECAUTIONS

Prior to operating this detector, read this “Safety precautions” carefully for correct use.

- In the precautions shown here, important contents on safety are included. So, be sure to observe them. The safety precautions have been ranked into “DANGER” and “CAUTION”.

 DANGER:	If this apparatus is abused, a dangerous condition could come about and it is supposed to die or get a serious injury.
 CAUTION:	If the apparatus is abused, a dangerous condition could arise and it is supposed to get medium injury or a minor injury and a physical damage is supposed to occur.
 PROHIBITION:	This indicates a prohibition (act which must not do).

Precautions in installing and wiring	
 DANGER:	<ul style="list-style-type: none"> • This product is not an explosion-proof type. Don't use it in an explosive gas atmosphere. Otherwise, irreparable troubles including explosion or a fire could occur.
 CAUTION:	<ul style="list-style-type: none"> • Install this product in a place compatible with the conditions set forth in “instruction manual”. The use at a place not conforming to the installation conditions may result in an electric shock, a fire and malfunction. • When this product is mounted on a furnace which is under operation, take utmost care with blow-out from the furnace. There is a risk of burn injury. • In the case of the wiring work, be careful not to drop foreign matters including wire chips into the product. Otherwise, a fire, failure or malfunction may result. • Connect a power source compatible with the specified rating. Connection of power source different from the rating might cause a fire. • Before doing the wiring work, be sure to turn off the main power. Otherwise, it results in getting an electric shock as the case may be. • Use proper wiring materials according to the rating of apparatus. If a wiring material which is not bearable to the rating is employed, it might cause a fire.
 PROHIBITION:	<ul style="list-style-type: none"> • Never do the work at a place where the product gets wet with water, such as the rain. A failure to observe this instruction may result in getting an electric shock or failure.

Precautions in operation, stop, maintenance and check



DANGER:

- In case where combustible gas is contained in the measured gas, check the gas composition and specifications carefully before using. Otherwise, the original performance is not displayed, and there is a fear of explosion.



CAUTION:

- Do the work in a condition where the main power has been turned off. If the work is done while current is flowing, there is a fear of getting an electric shock.
- The operating temperature of the detector (tip of ceramic heater) is about 800 °C and the surface temperature is also very high. So, never touch the detector by bare hand.
Otherwise, there is a fear of getting a burn.
- Before cleaning the flow guide tube, turn off the main power and cool the tube down fully.
There is a fear of getting a burn.
- Don't use any other renewal part than those designated by the maker. Otherwise, the original performance is not fully displayed and an accident or failure may result.
- Dispose of the renewal parts such as the maintenance parts as an incombustible.



PROHIBITION:

- Never do the work at a place where rain water splashes the product directly. A failure to observe this instruction may result in getting an electric shock or failure.

Other precaution



CAUTION:

- For a failure which cannot be judged even if referring to the instruction manual, be sure to ask the nearest dealer or Fuji adjustment serviceman for repair. If disassembled carelessly, an accident or injury could result.

CONTENTS

PREFACE	i
SAFETY PRECAUTIONS	ii
1. Introduction	1
1.1 General description of zirconia oxygen analyzer	1
1.2 Device configuration of direct insertion type oxygen analyzer.....	1
1.3 Description of each component.....	2
1.4 Check of type.....	2
1.5 Check of delivered articles	2
2. Mounting	3
2.1 Mounting location	3
2.2 Mounting method	3
3. Piping	7
3.1 Piping of calibration gas.....	7
3.2 Piping of reference gas inlet.....	7
3.3 Piping for blow down air.....	7
3.4 Piping drawing	8
4. Wiring.....	12
4.1 Before wiring.....	13
4.2 Wiring to each terminal	13
4.3 Mounting of conduit.....	14
5. Operation and Stop.....	15
5.1 Start of operation	15
5.2 Stop of operation	15
6. Maintenance and Check	16
6.1 Check.....	16
6.2 Maintenance	17
6.3 Standard output of detector	19
6.4 Arrangement.....	20
7. Troubleshooting.....	21
8. Appendix	22
8.1 Specification	22
8.2 Designation of type (code table)	24
8.3 Device composition	25
8.4 Outline diagram (unit: mm).....	26

1. INTRODUCTION

1.1 General description of zirconia oxygen analyzer

This zirconia oxygen analyzer makes use of the oxygen ion conductivity of solid electrolytes composed mainly of zirconia (ZrO_2) at high temperatures.

If electrodes of platinum or the like are attached to both faces of a solid electrolyte and the faces are on the conditions of different oxygen partial pressures, an electrochemical reaction causes an electromotive force between both the electrodes. This phenomenon is called concentration cell action.

Microscopically, it is assumed that electrochemical reactions occur at the interface (three-phase interface) among a solid electrolyte, electrode and oxygen.

High-oxygen partial pressure side: $O_2 + 4e^- \rightarrow 2O^{2-}$ (ionization)

Low-oxygen partial pressure side: $2O^{2-} \rightarrow O_2 + 4e^-$ (molecularization)

An electromotive force (E) generated is expressed as follows with Nernst's equation:

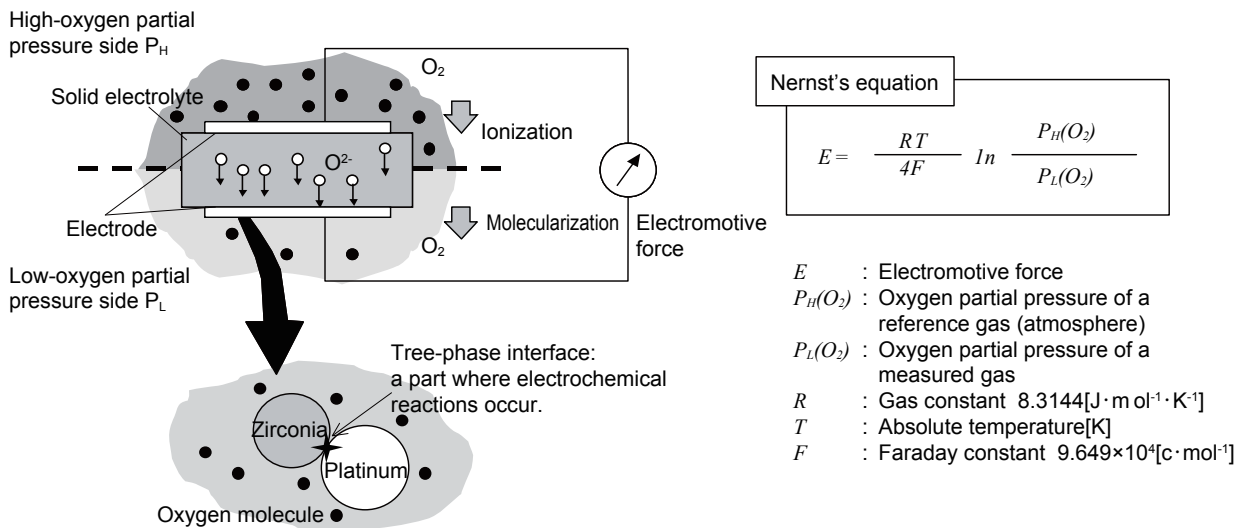

1.2 Device configuration of direct insertion type oxygen analyzer

The direct insertion type zirconia oxygen analyzer consists of the detector with a sensor unit, the flow guide tube that is directly inserted to the stack or the like in order to supply a gas to the detector, and the converter that performs sensor control, signal processing, output/display, and external transmission. The detector and converter are connected with a cable.

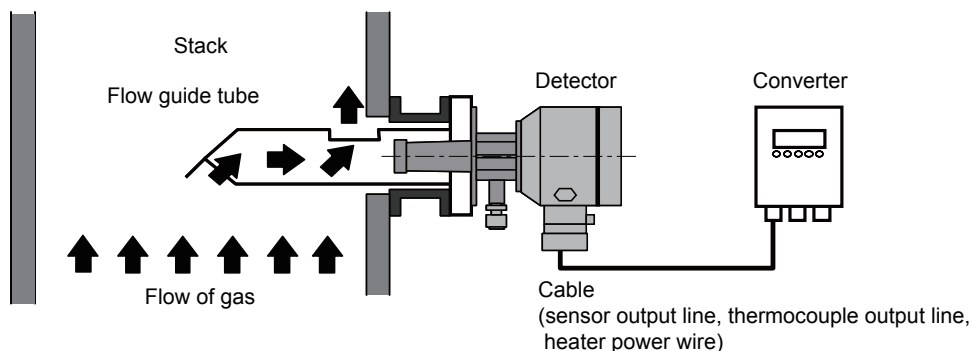

Replacement of the existing detector ZFK2 with the detector ZFK8:

In principle, the detector ZFK8 is compatible with the existing detectors ZFK2 and ZFK5 structurally and electrically.

However, the M4 screws for the terminal block of the detector were changed to the M3 screws. If using the existing cable, change the M4 terminal for cable end treatment on the detector side to the M3 terminal.

The detectors ZFK8, ZFK2 and ZFK5 can be connected to the converters ZRY, ZRM or ZKM.

The flow guide tube can be connected to the existing products.

Fuji Electric Co., Ltd.

International Sales Div

Sales Group

Gate City Ohsaki, East Tower, 11-2, Osaki 1-chome,
Shinagawa-ku, Tokyo 141-0032, Japan

<http://www.fujielectric.com>

Phone: 81-3-5435-7280, 7281 Fax: 81-3-5435-7425

<http://www.fujielectric.com/products/instruments/>

2. MOUNTING

2.1 Mounting location



DANGER

- This product has no explosion-proof specification. Don't use the product in an explosive gas environment. If used, a serious trouble such as a fire or explosion might occur.



CAUTIONS

- Install this product at a place compatible with the following conditions. The use of it at a place not conforming the installation conditions specified in this manual could cause an electric shock, a fire or incorrect operation.

Mount the detector by selecting the places shown below:

- 1 Place where there is a space which allows doing daily check and wiring work
- 2 Place where there is little vibration, dust and humidity
- 3 Place where peripheral air environment is non-corrosive.
- 4 Place where there are no electric appliances producing noise trouble (For example : motor, transformer and appliances bringing about electromagnetic induction trouble and electrostatic induction trouble) nearby the detector.
- 5 Place where ambient temperature and humidity are -10 to +60°C and less than 95%RH .

2.2 Mounting method



CAUTIONS

- When mounting the detector on a furnace which is under operation, take utmost care about the blowout from the furnace; otherwise, there is a fear of getting a burn.

2.2.1 Mounting method of detector

Caution in mounting

- Never mount the detector with the tip turned upward or downward. A failure of the detector may result.

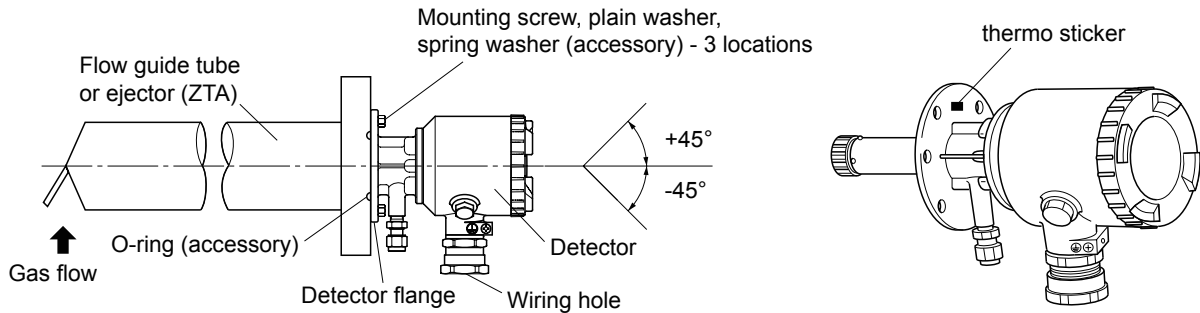
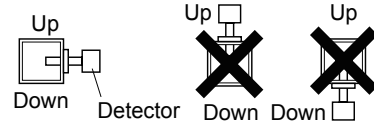

- 1 Attach the O-ring (accessory, Viton P36) to the groove of the detector. Subsequently, attach the detector to the flange of the flow guide tube or ejector (type: ZTA) by fixing the mounting screws (accessory, M5) and the flat and spring washers (accessories) to the three locations (at the opposing corners of six mounting holes) (recommended tightening torque: 3.5 N · m).
- 2 Attach the detector so that it is within the range of $\pm 45^\circ$ to the horizontal plane.
- 3 Attach the detector so that the wiring hole is located at the bottom.
- 4 Set the temperature of the detector flange to 125°C or less regardless of the measured gas temperature.

<How to check>

- Complete the mounting, piping and wiring of the detector, make sure the color of thermo sticker 125 put on the detector flange is not changing to red in the exhaust gas measuring condition (while current is flowing to the detector and the plant is under running). (Usually, the color of thermo sticker is light pink.)
- If the color has changed to red, it means that the temperature of detector flange has been over 125°C. So, take the following steps:
 - (a) Change the existing flange packing to a thicker one.
 - (b) Use a longer mating flange.
 - (c) Mount the flow guide tube according to Item “2.2.2”.

By taking the above steps, minimize heat transfer from the gas duct wall and lower the temperature.

The thermo sticker does not return to its original condition once it discolors. So, after taking the steps, re-put a thermo sticker available as an accessory on the detector flange and make certain that it does not turn red. (For the part No. for additional procurement of the thermo sticker, refer to Item “6.4”.

2.2.2 Mounting method of flow guide tube

(Designation of type: When 9th to 11th digits are 5A□, 5B□ and 5C□)

The flange of flow tube has mounting holes at 8 locations. These holes are available for regulating an in-flow into the flow guide and mounting the tube correctly in the flowing direction of gas and it is enough if mounted at 4 locations.

(1) Direction of tongue and Partition plate of flow guide tube

- 1 When exhaust gas temperature is under 200°C and gas flowing velocity is low

As illustrated below, set the partition plate inside the flow guide tube at a right angle to the gas flow and mount the tube so that the tongue turns to an upstream direction relative to the gas flow.

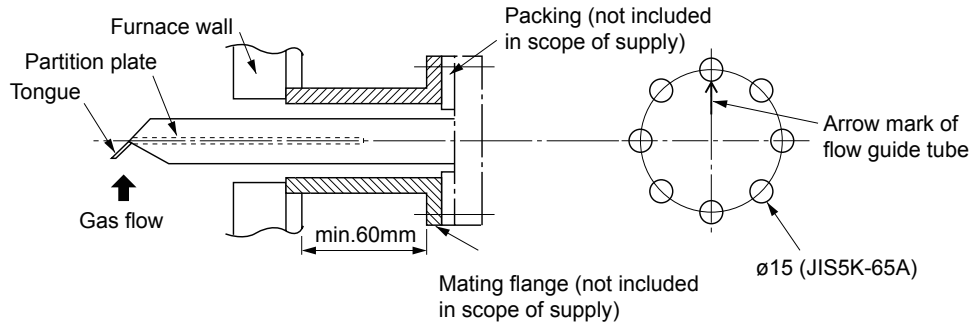

- 2 When exhaust gas temperature is 200°C or higher and gas flowing velocity is fast

As illustrated below, tilt the partition plate inside the flow guide tube 45° to the gas flow and mount the tube so that the tongue turns to a down-stream direction relative to gas flow.

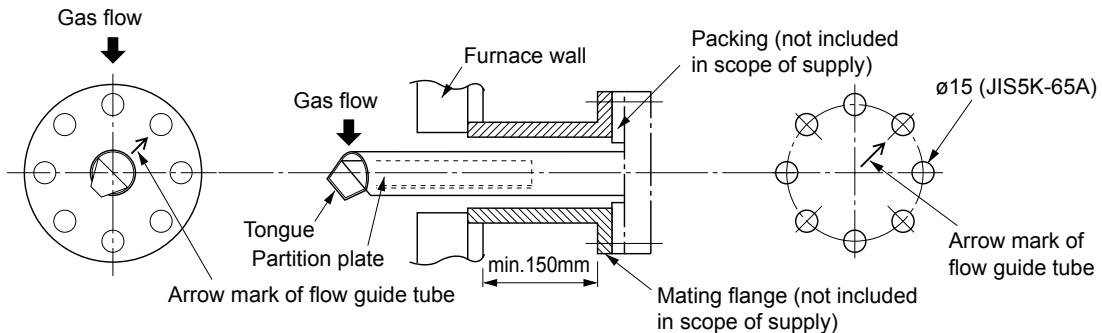

(2) Inserting angle of flow guide tube

According to the temperature of exhaust gas and the amount of dust, the inserting angle of the flow guide tube differs. With reference to the following conditions, install a mating flange.

- 1 When exhaust gas temperature is under 200°C and amount of dust is under 0.2g/Nm³

(Designation of type: When 9th to 11th digits are 5A□)

- Inserting angle: within a range of -45 to +45°

- 2 When exhaust gas temperature is 200°C or higher and amount of dust is under 0.2g/Nm³

(Designation of type: When 9th to 11th digits are 5A□)

- Inserting angle: within a range of -20 to +20°

- 3 When amount of dust is over 0.2g/Nm³

(Designation of type: When 9th to 11th digits are 5B□ and 5C□)

- Inserting angle: within a range of 0 to +45°

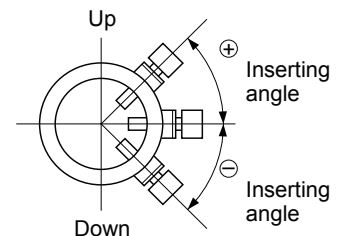

2.2.3 Mounting method of high dust-use flow guide tube
 (Designation of type : When 9th to 11th digits are 6D□ and 6E□)

Mount the tube so that the gas outlet turns downward relative to the gas flow as shown below.

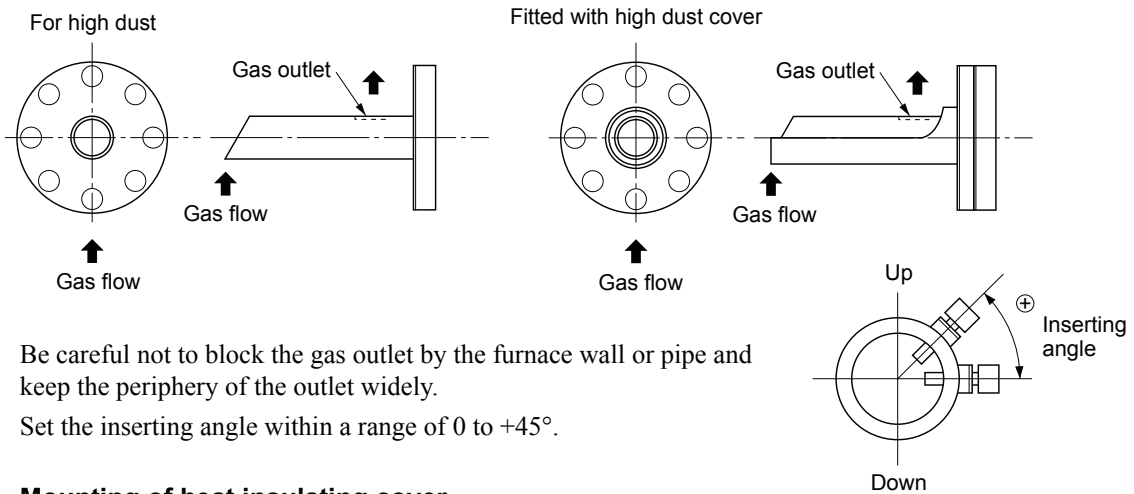

Be careful not to block the gas outlet by the furnace wall or pipe and keep the periphery of the outlet widely.

Set the inserting angle within a range of 0 to +45°.

2.2.4 Mounting of heat insulating cover

For using at a cold district, use a heat insulating cover (For the part No. for additional procurement of the heat insulating cover, refer to Item "6.4").

- Put M4-mounting screw of the heat insulating cover into M4-heat insulating cover fixing tapped hole of the terminal box with M4-screw ring put between the tapped hole and screw.
- Do not use a heat insulating cover in the place where the temperature is high.

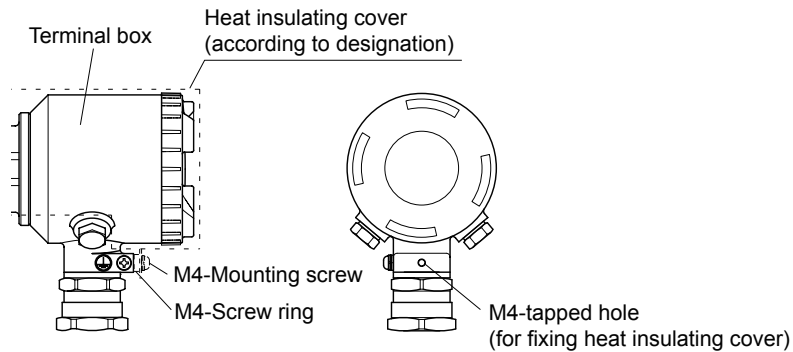

3. PIPING

3.1 Piping of calibration gas

As the piping material, use a teflon-made $\phi 6\text{mm}$ or $\phi 1/4\text{inch}$ tube.

- From the coupling attached to the detector, remove (2) nut, (3) front ferrule and (4) back ferrule, put them through to the $\phi 6\text{mm}$ or $\phi 1/4\text{inch}$ teflon tube for piping, and then attach it to (1) coupling.
- For mounting (2) nut, tighten by making about 2 turns with a spanner after it cannot be turned any more by hand.

Joint for calibration gas:

The joint for calibration gas is a special joint with a built-in check valve. If a malfunction occurs, order the joint for calibration gas and attach it.

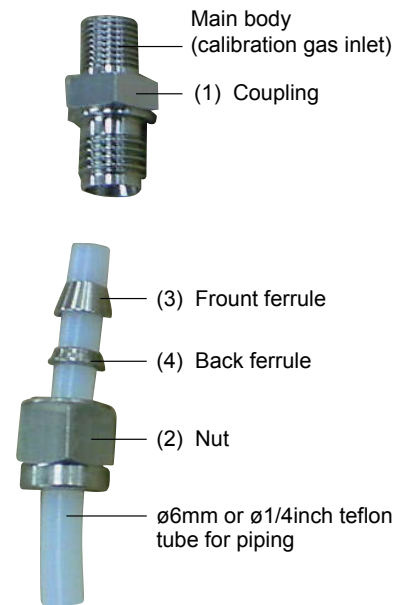

3.2 Piping of reference gas inlet

If the atmosphere around the terminal box is significantly dirty or the humidity of the location is extremely high, install piping for reference gas.

If the 13th digit of the type is “A” or “B,” the piping for reference gas is delivered together with the detector body.



CAUTIONS

- When used at an ordinary place (oxygen concentration : 20.6vol%), the reference gas is unnecessary. So, don't remove a hexagonal plug of the mounting port of reference gas inlet unnecessarily since a waterproofness becomes poor.

Refer to the previous section “3.1 Piping of calibration gas” for the installation method of piping.

Set one of the two reference gas ports as “inlet” and the other as “outlet.”

Install piping so that dust or water does not enter the “outlet.”

Attachment of joints for reference gas:

If you order the joints for reference gas additionally, remove the hexagonal plugs and attach the joints for reference gas (two locations) as shown in the figure on the right.

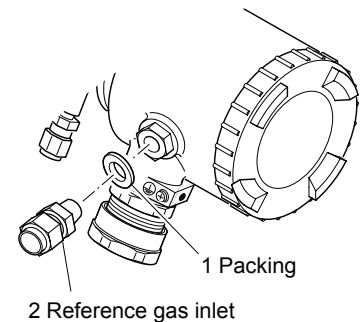

3.3 Piping for blow down air

Connect the blow air inlet (4 locations) of blowdown-fitted flow guide tube by detaching a plug of the upper-side blow port (1 location) so that drain does not accumulate.

For the blow piping, use a copper tube equivalent to 15A SGP or larger (tube having larger inside diameter) or $\phi 10/\phi 8$ teflon tube. And, use L-shape joint or union without bending the pipe wherever possible and keep the piping length as short as possible.

Flow guide tube system

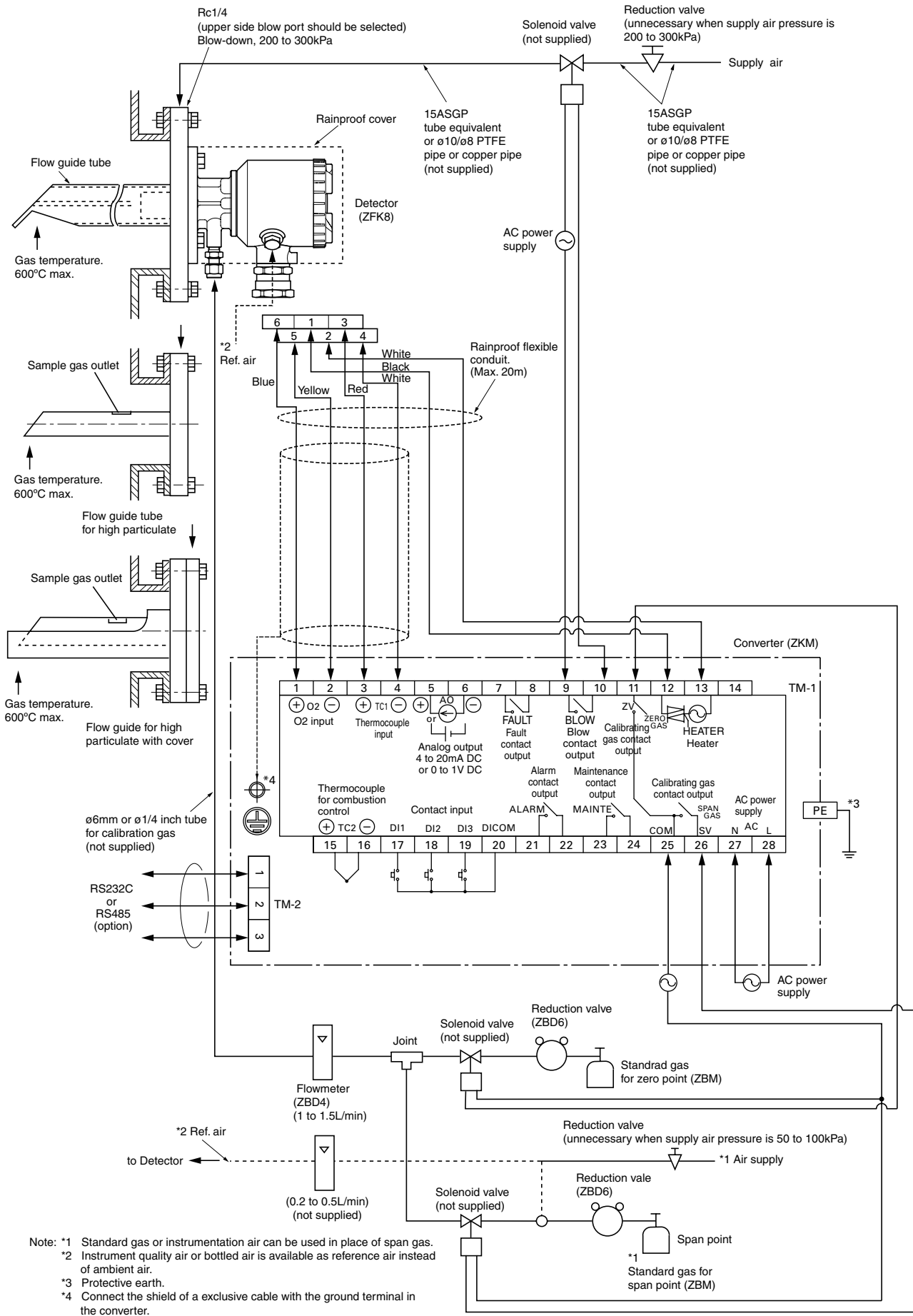

- Note: *1 Standard gas or instrumentation air can be used in place of span gas.
 *2 Instrument quality air or bottled air is available as reference air instead of ambient air.
 *3 Protective earth.
 *4 Connect the shield of a exclusive cable with the ground terminal in the converter.

Ejector system (with valve)

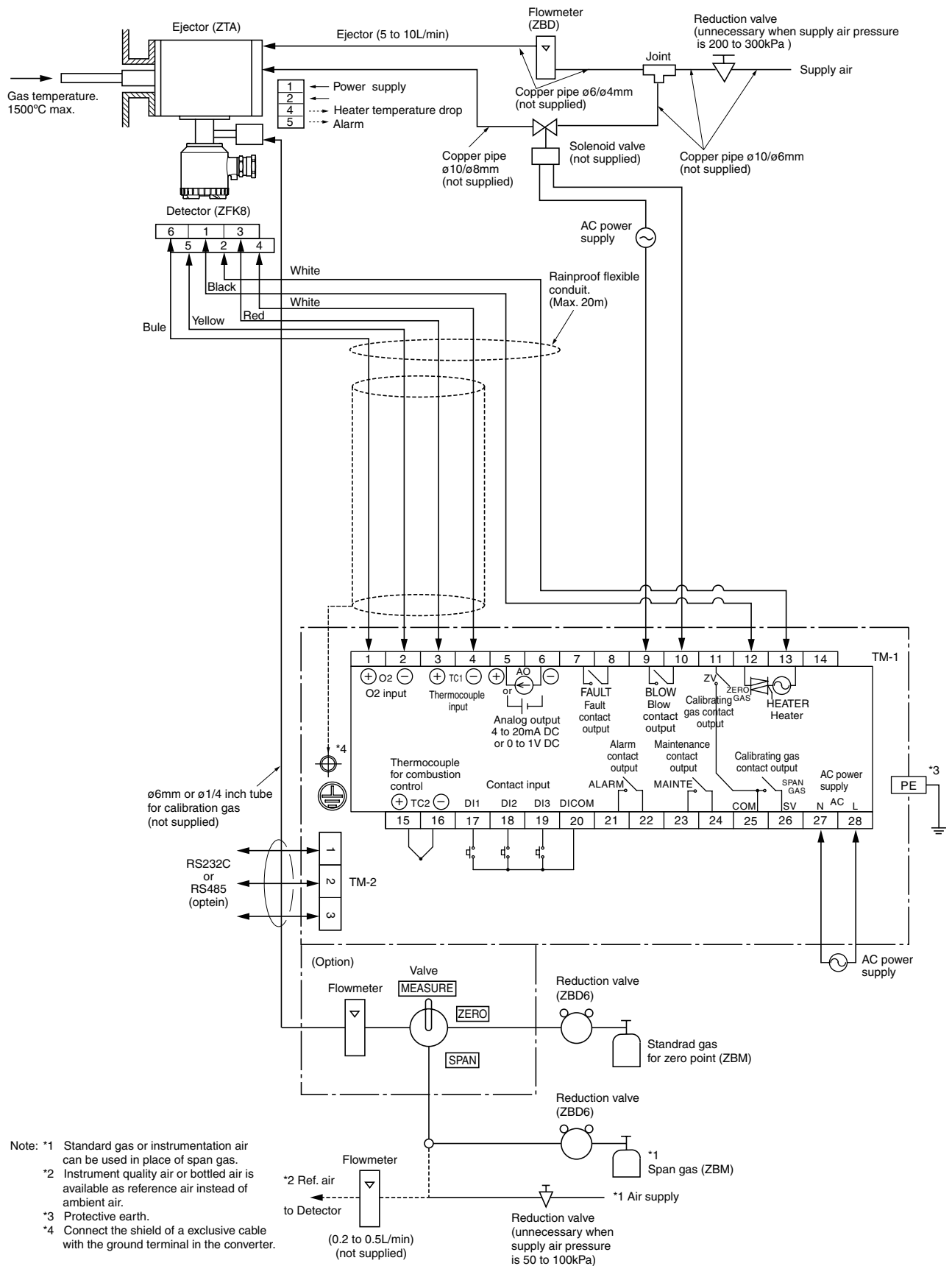

Ejector system

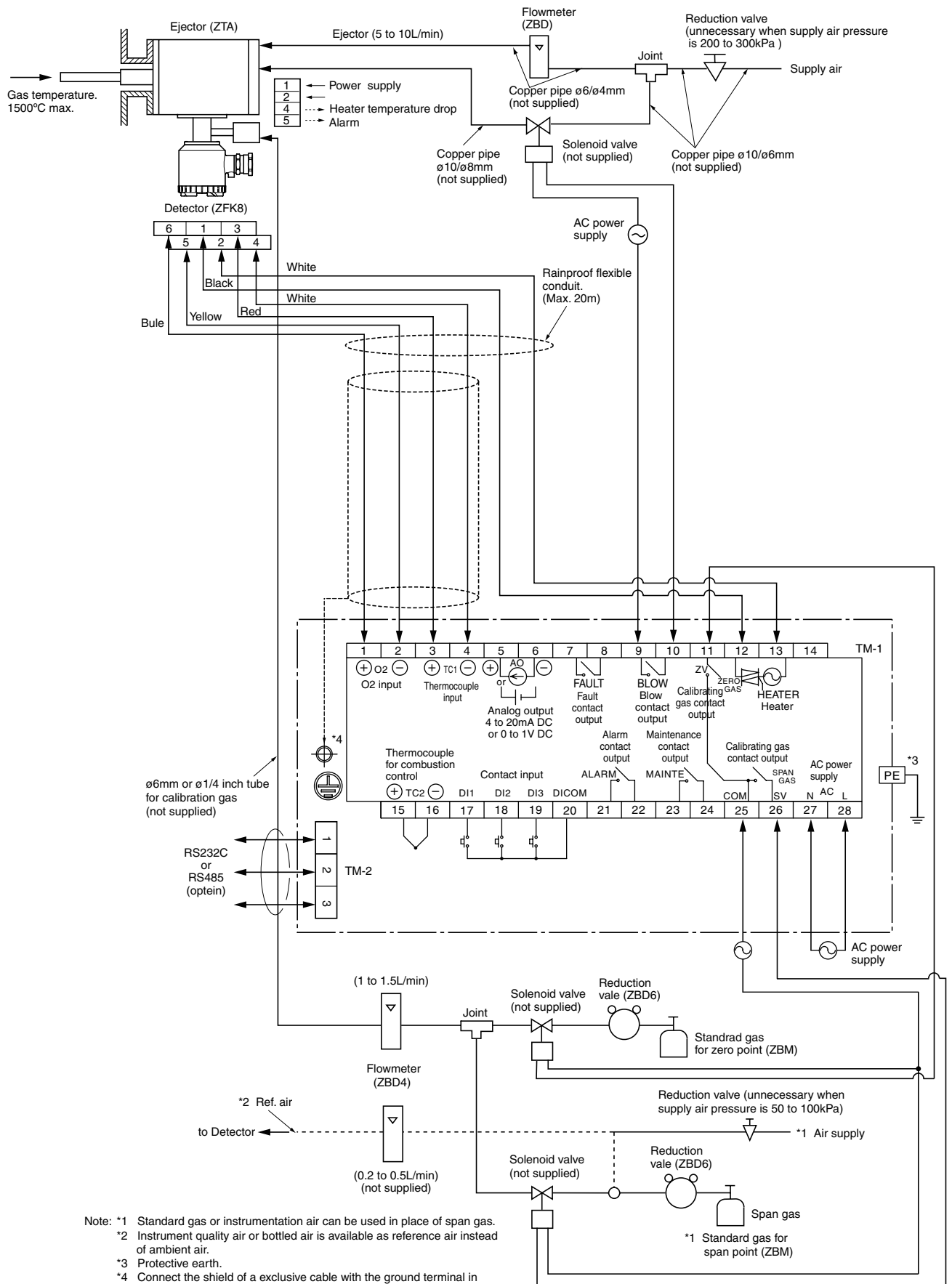

4. WIRING



CAUTIONS

- In the case of the wiring work, be careful not to drop foreign matters including wire chips inside the product. Otherwise, this might cause a fire, failure or malfunction.
- Connect a power source compatible with the rating. Connection of a power source not conforming to the rating may cause a fire.
- Before proceeding with the wiring work, be sure to turn off the main power supply. Otherwise, there is a fear of getting an electric shock.
- As the wiring material, use a proper one conforming to the rating of apparatus. The use of a wiring material which is not bearable to the rating could cause a fire.



PROHIBITION

- Under no circumstances be the work at a place where the product gets wet with water, such as the rain. Otherwise, an electric shock or failure may result.

4.1 Before wiring

Put a cable (6 cores in all) connected between detector and converter into a piping tube for protecting the cable. Also, put the cables for R thermocouple and element output away from the power cable to take a noise preventive step.

When an exclusive cable is not used, use the following wire rods:

- For heater (2 pcs.) 3A or more in rating
- For R thermocouple Specified in JIS C1610-1995 (equivalent to RCA-2-G-0.75mm²-S₂).
- Recommended wire rod (at 20 °C)

		For heater	Element output compensation conductor
Composition	Nominal sectional area (mm ²)	0.75	
	Number of composed element wires/ diameter of element wire (mm)	30/0.18	
	Outside dia. (mm)	1.1	1.14
	Thickness of vinyl insulating material (mm)	0.6	
	Thickness of vinyl sheath (mm)	1.0	1.5
Max. conductor resistance per unit length (Ω/km)		24.4	—
Test voltage (V)		1000	1500
Insulation resistance per unit length (MΩ•km)		5	40
Rating (A)		7	—

For wiring of the detector, be sure to use a solderless terminal (for M3).

- Recommended solderless terminal Solderless terminal prescribed in JIS C 2805 (Nominal designation: R1.25-3)

4.2 Wiring to each terminal



CAUTIONS

- Be careful not to mix up the wiring for thermocouple (four-core, white) and the wiring for heater (two-core, white).

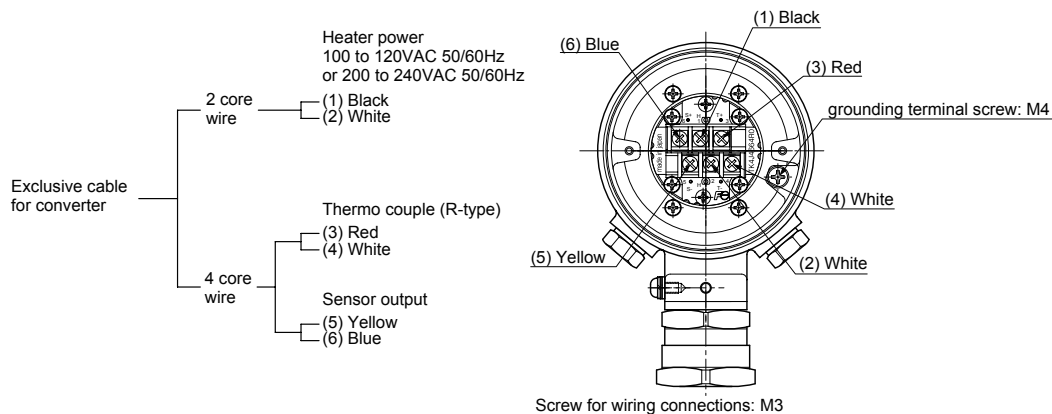

Connect the protective grounding to one of the two terminals in the figure below. (Class D (Class 3) grounding, grounding resistance: 100Ω or less)

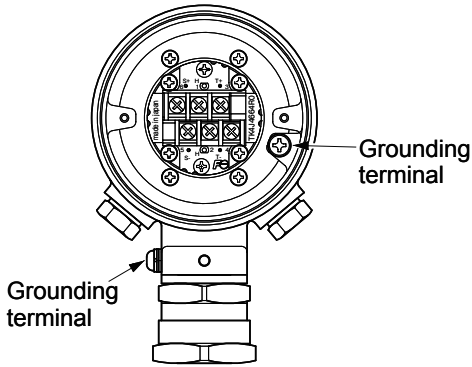

Wiring of protective grounding terminal

Attach the solderless terminals to the grounding terminals with them between the tooth lock washer and screw with washer .

(recommended tightening torque: 1.8 N·m)

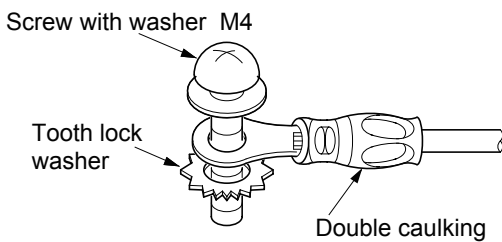

Note

- Use the cable more than 0.75mm² for main ground (earth) line.
- For solderless terminal , doubly caulk the core and the sheath separately.

- Use “◎” type of solderless terminal .

4.3 Mounting of conduit

- Remove (2) packing holder nut,(3) packing and (4) bushing from M coupling of the main body.
- Fit the (2) packing holder nut and (3) packing onto the conduit and fit the end face of conduit into a groove of the (4) bushing.
- Insert the (4) bushing fitted to the conduit into (1) M coupling of the main body and tighten with the (3) packing and (2) packing holder nut for fixing.

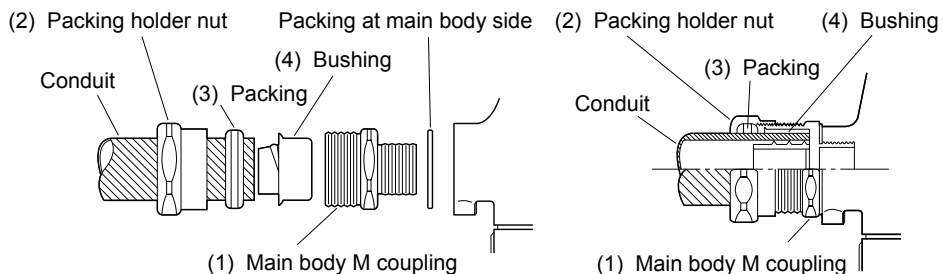

5. OPERATION AND STOP



DANGER

- In case where combustible gas is contained in the measured gas, make sure of the gas composition and specifications carefully before using this product. Otherwise, the original performance is not displayed and there is a fear of explosion.

5.1 Start of operation

- If the power switch of the converter is turned on after completion of wiring and piping work, the detector starts its operation.
- After warm-up at least 10 minutes, start the operation of the furnace.
- After zero calibration and span calibration have finished, get to work on the measurement.
- For the method of calibration, refer to each instruction manual of converters (ZKM, ZRM and ZRY).
- When the converters (ZKM, ZRM and ZRY) are not used, run the zero and span calibration gases and calibrate by converting the output in a stabilized state into oxygen concentration according to the standard output table of converter in Item. "6.3".
If using the reference gas, supply it before the calibration. (flow rate: 0.2 to 0.5L/min)

5.2 Stop of operation

If the power is turned on in a state of dew condensation, it leads to the failure of detector. Stop the operation following the procedures described below.

(1) In case of short-term shutdown (about 1 week) of furnace

- Keep the power supply of the detector (converter) turned "ON". This can prevent the detector from getting dewed.

Also, note that if "ON-OFF" is repeated in a condition where the detector has dewed (according to the furnace and ambient conditions), the detector might fail.

- When the ejector (ZTA) is in use, stop the air supply to the ejector.

(2) In case of long-term shutdown of furnace

- Turn off the power of the detector (converter) after the peripheral air of the detector inside the furnace (especially, temperature and humidity) has become an air environment. Or, turn off the power after taking the detector out of the furnace and leaving it as it is for 15 minutes or more.
- When the ejector (ZTA) is in use, stop the air supply to the ejector.

6. MAINTENANCE AND CHECK



CAUTIONS

- Do the work in a condition where the main power supply has been turned off.
If the work is done while current is flowing, there is a fear of getting an electric shock.
- The operation temperature of the detector (tip of the ceramic heater) is about 800°C and the surface temperature is also very high. So, never touch it by bare hand. Otherwise, there is a fear of getting a burn.
- Before proceeding with the cleaning of the flow guide tube, turn off the main power and cool the tube down fully and then, do the work. Otherwise, there is a fear of getting a burn.
- Don't use other renewal parts than those designated by the maker. Otherwise, the original performance is not displayed fully and an accident or failure could come about.
- Dispose of the renewal parts including the maintenance parts as an incombustible.



PROHIBITION

- Under no circumstances the work at a place where the product gets wet with water, such as the rain. Otherwise, an electric shock or failure may result.

6.1 Check

Perform the check periodically for using the product always in good condition. Especially, perform the checks shown in table below. Moreover, perform the periodic check at a time of checking the furnace or every 6 months.

	Check items	Details of checking work
Daily check	Execution of zero & span calibration	<ul style="list-style-type: none"> • When the converters (ZKM, ZRM and ZRY) are in use: With reference to the instruction manuals of the converters (ZKM, ZRM and ZRY), check once a week as a rough standard. (calibration gas flow rate : 1.5 to 2.0L/min) • When the converters (ZKM, ZRM and ZRY) are not used: Running the zero and span calibration gases, make calibration once a week as a rough standard by converting the output in a stabilized state into oxygen concentration according to the standard output table of converter in Item "6.3".
	Check for looseness of cable gland.	Retighten the cable gland or if the packing is found deteriorated, replace.
	Check of residue in calibration gas cylinder	Check it by a primary pressure gauge.
	Check of blowdown (when blowdown nozzle is fitted)	Referring to each instruction manual of the converters (ZKM, ZRM and ZRY), check at 200 to 300kPa.
Periodic check	Check for leak from packing fitted between flow guide tube and mating flange and O-ring of detector.	If either of the packing and O-ring or both of them are found deteriorated, replace with new O-ring (refer to the part No. for procurement in Item "6.4") and replace the packing (not included in scope of supply).
	Removing detector, check for clogging of ceramic filter of detector.	When it is necessary to replace the ceramic filter, refer to Item "6.2.2".
	Check by disconnecting for clogging or corrosion of flow guide tube.	Check following the procedure in Item "6.2.3".
	Check by removing for clogging or corrosion of sampling probe of ejector (ZTA).	Check following the procedure in Item "6.2.4".
	Check by removing if air outlet port of ejector (ZTA) is left stopped up.	Clean the air outlet port of the thermal insulation part of furnace wall.

6.2 Maintenance

The replacing intervals of sensor unit, ceramic filter and O-ring, and the maintenance periods of flow guide tube and sampling probe differ depending on the working conditions including the components of measured gas and the amount of dust.

The replacing intervals in a general conditions are shown below. Determine the replacing intervals in the individual working condition with a period till a first replacement after delivery and operation as a rough standard.

- Sensor unit..... Yearly
- Ceramic filter..... At 6 month interval
- Flow guide tube..... At 3 to 4 year interval
- ZTA sampling probe..... At 3 to 4 year interval
- O-ring Yearly

6.2.1 Replacement of Sensor unit

Caution about the replacement of the sensor unit:

- Check that the sensor unit complies with the specifications of the power supply you use.
- Avoid replacing the sensor unit while the current is applied.
- The temperature of the detector becomes high. Replace the sensor unit after the temperature is reduced sufficiently.

- (1) Turn off the power for the detector. (Set the switch of the converter or the main power supply to “OFF”.)
- (2) Check that the surface temperature of the detector is reduced sufficiently.
- (3) Remove the terminal box cover and then remove the terminal block cover in the terminal box (M3 screw, two locations).
- (4) Remove the six wires connected the terminal block of the sensor unit (M3 screws, six locations).
- (5) Remove the screw with washer (M3 screws, four locations) fastening the sensor unit .
- (6) Remove the sensor unit and o-ring from the detector.
- (7) Attach the supplied O-ring of the replacement sensor unit to the groove for the O-ring at the detector.
- (8) Attach the replacement sensor unit to the detector.
(Attach the sensor unit so that the rotational direction is as shown in the figure below.)
- (9) Fasten the sensor unit with the supplied screw with washer (M3 screws, four locations).
(recommended tightening torque: 0.7 N·m)
- (10) Connect six wires to the terminal block of the sensor unit and attach the terminal block cover.
- (11) Attach the terminal box cover.

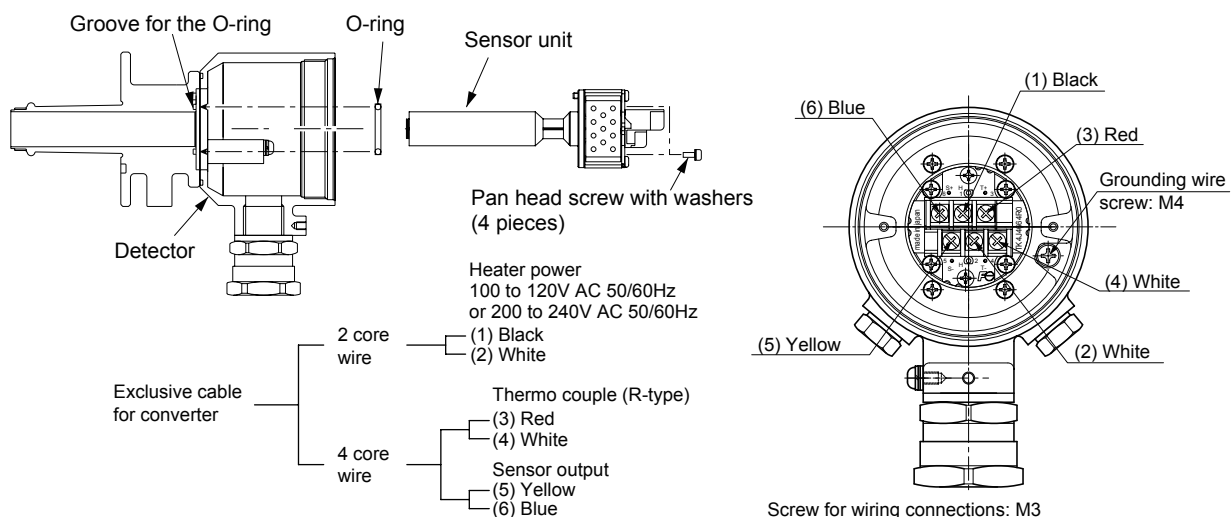

6.2.2 Replacement of ceramic filter

- (1) After turning “OFF” the power of the detector, lower the surface temperature of the tip (at the ceramic filter side) by cooling down fully with the air.
- (2) After having been cooled down fully, remove the filter frame from the detector, take the ceramic filter and reflector off the filter frame.
- (3) Set a new ceramic filter and reflector in the filter frame and fit the frame to the detector and then, tighten till the ceramic filter does not move any longer. (Be careful then not to fail to set the reflector in place. For the part No. for additional procurement of the reflector, refer to Item. “6.4”).

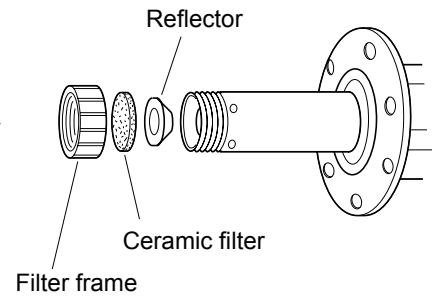

6.2.3 Maintenance of flow guide tube

- After removing the flow guide tube from the furnace wall and then, from the detector, cool the tube down fully in the air.
- Remove dust sticking to the outside of the flow guide tube by water-washing with the use of a scrubbing brush.
- Remove dust sticking to the inside of the flow guide tube by using a metallic rod or screwdriver. (Clean so that tube is through at least about 3/4 part of the whole interior.)
- For the flow guide tube for high dust, remove together dust sticking around the gas outlet.

6.2.4 Maintenance of sampling probe

- After removing the ejector (ZTA) from the furnace wall and then, the sampling probe from the ejector, cool the probe down fully in the air.
- Remove dust sticking to the outside of the flow guide tube by using a scrubbing brush.



CAUTIONS

- The high temperature-use sampling probe (made of SIC) of the ejector (ZTA) is liable to break. So, be careful not to cool abruptly by water (quenching) or apply undue force to the probe in the dust removing work.
- Remove dust sticking to the inside of the flow guide tube by using a metallic rod or screwdriver. (Clean so that the tube is through at least about 3/4 part of the whole interior.)

6.3 Standard output of detector

For the output voltage of the detector, refer to the standard output table below.

Standard output table (Reference)

Oxygen concentration (Vol%)	Detector output (Unit: mV)
0.01	168.15
0.05	132.68
0.1	117.41
0.5	81.94
1.0	66.67
1.2	62.65
1.4	59.25
1.5	57.73
1.6	56.31
1.8	53.71
2.0	51.39
2.2	49.29
2.4	47.37
2.5	46.47
2.6	45.61
2.8	43.98
3.0	42.46

Oxygen concentration (Vol%)	Detector output (Unit: mV)
3.5	39.06
4.0	36.12
4.5	33.52
5.0	31.20
5.5	29.10
6.0	27.18
6.5	25.42
7.0	23.79
7.5	22.26
8.0	20.84
8.5	19.51
9.0	18.25
9.5	17.06
10.0	15.92
11.0	13.82
12.0	11.91
13.0	10.14

Oxygen concentration (Vol%)	Detector output (Unit: mV)
14.0	8.51
15.0	6.99
16.0	5.57
17.0	4.23
18.0	2.97
19.0	1.78
20.0	0.65
20.6	0.00
21.0	-0.43
22.0	-1.45
23.0	-2.43
24.0	-3.37
25.0	-4.27
30.0	-8.29
35.0	-11.68
40.0	-14.62
45.0	-17.22
50.0	-19.54

6.4 Arrangement

No.	Description	Classification	Part No. for procurement (Procured type)	Remark
1	Ceramic filter	Consumable	*ZZPZFK5-TK750201P1	
2	Detector O-ring (P38)	Consumable	*ZZPZFK5-8552836	Viton
3	Sensor unit for replacement	Spare parts	According to designation of type in Item. "8.2"	screw with washer (M3×8): 4 pcs. O-ring (S22.4, Viton) : 1 pc.
4	Flow guide tube	Spare parts	According to part No. for procurement of flow guide shown in table below	
5	Calibration gas inlet (for φ6mm tube)	Additionally procurement part	*ZZPZFK5-TK7N6820C1	
6	Calibration gas inlet (for 1/4 inch tube)	Additionally procurement part	*ZZPZFK5-TK7N6820C2	
7	Thermo sticker	Additionally procurement part	*ZZPZFK5-TK746983P1	
8	Reference gas inlet (for φ6mm tube)	Additionally procurement part	*ZZPZFK5-TK7K1652P9	Gasket included. (2 pieces are required for the standard gas inlet/outlet.)
9	Reference gas inlet (for 1/4 inch tube)	Additionally procurement part	*ZZPZFK5-TK7K1652P10	Gasket included. (2 pieces are required for the standard gas inlet/outlet.)
10	Reflector	Additionally procurement part	*ZZPZFK5-TK7H6762P1	
11	Heat insulating cover	Additionally procurement part	*ZZPZFK5-TK4E5339C1	

Part No. for procurement of flow guide

Type designation digits			Procurement DWG. No.	Classification	Inserting length
9	10	11			
5	A	3	*ZZP-TK464430C1	For general use	300mm
5	A	5	*ZZP-TK464430C2	For general use	500mm
5	A	7	*ZZP-TK464430C3	For general use	750mm
5	A	1	*ZZP-TK464430C4	For general use	1000mm
5	B	3	*ZZP-TK4B5999C1	Corrosive gas	300mm
5	B	5	*ZZP-TK4B5999C2	Corrosive gas	500mm
5	B	7	*ZZP-TK4B5999C3	Corrosive gas	750mm
5	B	1	*ZZP-TK4B5999C4	Corrosive gas	1000mm
5	C	3	*ZZP-TK4A3274C1	Fitted with blowdown nozzle	300mm
5	C	5	*ZZP-TK4A3274C2	Fitted with blowdown nozzle	500mm
5	C	7	*ZZP-TK4A3274C3	Fitted with blowdown nozzle	750mm
5	C	1	*ZZP-TK4A3274C4	Fitted with blowdown nozzle	1000mm
6	D	8	*ZZP-TK7H8487C3	High dust flow guide tube	800mm
6	E	8	*ZZP-TK7H8487C3 *ZZP-TK7H8489C2	Fitted with high dust flow guide tube cover	800mm

7. TROUBLESHOOTING



CAUTIONS

- If a failure should occur which cannot be judged even if referring to the operation manual, be sure to ask the nearest dealer or Fuji adjustment serviceman for repair. If disassembled carelessly, there is a fare of an accident or injury.

Troubles	Probable causes	Check procedures (normal values)	Remedies
<ul style="list-style-type: none"> Indication is fixed. Indication response is slow. 	<ul style="list-style-type: none"> Clogging of ceramic filter of detector and flow guide tube interior 	<ul style="list-style-type: none"> Check visually for fouling of ceramic filter of detector and clogging of flow guide tube interior with dust. 	<ul style="list-style-type: none"> Clean or exchange ceramic filter, if need be.
	<ul style="list-style-type: none"> Leak from joint and airtightness of mounted part. 	<ul style="list-style-type: none"> Check for looseness of each joint and airtightness of mounted part. 	<ul style="list-style-type: none"> Retighten and replace joint(s), if need be.
	<ul style="list-style-type: none"> Deterioration of detector 	<ul style="list-style-type: none"> Check by changing zero calibration gas over to span calibration gas and vice versa if it takes more than 5 minutes for 90% response. 	<ul style="list-style-type: none"> Replace detector.
	<ul style="list-style-type: none"> Decrease of exhaust gas flowing velocity 	<ul style="list-style-type: none"> Check exhaust gas responding time after stop of calibration gas supply. 	<ul style="list-style-type: none"> Increase amount of exhaust gas inside flow guide tube to be taken in. Clean flow guide tube.
<ul style="list-style-type: none"> Temperature alarm continues coming on despite 20 minutes having elapsed after turning on power. 	<ul style="list-style-type: none"> Disconnection of cable 	<ul style="list-style-type: none"> Check continuity. 	<ul style="list-style-type: none"> Replace cable.
	<ul style="list-style-type: none"> Error in wiring 	<ul style="list-style-type: none"> Check wiring. 	<ul style="list-style-type: none"> Wire correctly.
	<ul style="list-style-type: none"> Low supply voltage 	<ul style="list-style-type: none"> Check if supply power is as specified. 	<ul style="list-style-type: none"> Supply correct power.
	<ul style="list-style-type: none"> Disconnection of thermocouple 	<ul style="list-style-type: none"> Check continuity. Check if resistance across terminals No. 3 and No. 4 is 2 to 3Ω. 	<ul style="list-style-type: none"> Replace detector.
	<ul style="list-style-type: none"> Blow out of fuse of converters (ZKM, ZRM and ZRY) 	<ul style="list-style-type: none"> Check continuity of fuse. 	<ul style="list-style-type: none"> Exchange fuse(s). (Refer to each instruction manual of converters ZKM, ZRM and ZRY).
<ul style="list-style-type: none"> Indication is too high or too low. 	<ul style="list-style-type: none"> Looseness of flange mounted part or defects of O-ring or packing (not included in scope of supply). 	<ul style="list-style-type: none"> Check airtightness of detection unit, flow guide tube and flange mounted part. 	<ul style="list-style-type: none"> Retighten mounting screw. Exchange O-ring. Exchange packing (not included in scope of supply)
		<ul style="list-style-type: none"> Check for leak in from periphery. 	<ul style="list-style-type: none"> Shield
	<ul style="list-style-type: none"> Deterioration of detector 	<ul style="list-style-type: none"> Check airtightness of calibration gas supply port. Check at a time of running zero and span calibration gases if detector output (mV) is higher or lower than others. (Refer to Table in Item "6.3"). 	<ul style="list-style-type: none"> Retighten calibration gas joint. Replace detector.
	<ul style="list-style-type: none"> Abnormality of detector temperature 	<ul style="list-style-type: none"> Check indicated temperature of converter. 	
	<ul style="list-style-type: none"> Change of ambient air oxygen concentration of a terminal box or very high humidity 	<ul style="list-style-type: none"> Check ambient air oxygen concentration of a terminal box is 20.6vol%. 	<ul style="list-style-type: none"> Use reference gas inlet.

8. APPENDIX

8.1 Specification

8.1.1 General

- **Measuring object:** Oxygen in noncombustible gas
- **Measuring method:** Direct insertion type zirconia system
- **Measuring range:** 0 to 2 ... arbitrary 2 ranges are settable at 50vol%O₂ (in 1 vol% O₂ steps)
- **Repeatability:** Within ±0.5%FS
- **Linearity:** Within ±2%FS
- **Response time:** Within 4 to 7 sec, for 90% (from calibration gas inlet)
- **Warmup time:** More than 10 min
- **Analog output:** 4 to 20mA DC (allowable load resistance 500Ω or less) or 0 to 1V DC (output resistance 100Ω or more)
- **Power supply:** Rated voltage;
100 to 120V AC (operating voltage 90 to 132V AC)
200 to 240V AC (operating voltage 190 to 264V AC)
Rated frequency; 50/60Hz
- **Power consumption:** Maximum 240VA (Detector: approx. 200VA, Converter: approx. 40VA)
Normal 70VA (Detector: approx. 50VA, Converter: approx. 20VA)

8.1.2 Oxygen detector (ZFK8) and ejector (ZTA)

- **Measured gas temperature:**
Flow guide tube system; -20 to +600°C
(for general-use, corrosive gas)
Ejector system; -20 to +1500°C
(for high-temperature gas)
-20 to +800°C (for general-use)
- **Measured gas pressure:**
-3 to +3kPa
- **Flow guide tube:** With or without blow-down nozzle
Flange; JIS5K 65A FF
(JIS5K-80AFF for high particulate gas)
Insertion length; 0.3, 0.5, 0.75, 1m
(0.8m for high particulate gas)
- **For high particulate (with blowdown nozzle):**
With/without cover
Flange; JIS5K 80AFF
Insertion length; 0.8. (standard)
- **Ejector (general-use):**
Probe for guiding measured gas to detector
Flange; JIS10K 65A RF
Insertion length; 0.5, 0.75, 1, 1.5m
(according to customer's specification)
- **Operating temperature:**
-20 to +60°C for detector
-5 to +100°C for ejector section
125°C or less at detector flange surface with power applied
- **Storage temperature:**
Detector: -30 to +70°C
Ejector: -10 to +100°C
- **Structure:** Dust/rain-proof structure (IEC IP66 equivalent)
- **However, except a filter on edge:**
Heat insulating cover is required in cold climates (as specified)
- **Filter:** Alumina(filtering accuracy 50μm) and quartz paper

- **Main materials of gas-contacting parts:**
Detector; Zirconia,SCS14, SUS316, platinum
Flow guide tube; SUS304 or SUS316
Ejector (general use); SUS316, SUS304
Ejector; (for high temperature) SiC, SUS316, SUS304
- **Calibration gas inlet:**
Inlet for ø6mm tube or ø1/4inch tube (as specified)
- **Reference gas inlet (option):**
Inlet for ø6mm tube or ø1/4inch tube (as specified)
- **Detector mounting:** Horizontal plane ±45°, ambient air should be clean.
- **Outer dimensions:** (L × max. dia.) 210mm × 100mm
- **Mass (approx.) {weight}:**
Detector; 1.6kg
Ejector; 15kg (insertion length 1m)
Flow guide tube (general-use, 1m); 5kg
- **Finish color:** Silver and SUS metallic color
- **Ejector air inlet flow rate:**
5 to 10 L/min
- **Calibration gas flow:**
1.5 to 2 L/min
- **Blowdown air inlet pressure:**
200 to 300kPa
- **Ejector exhaust gas processing:**
Returned to inside the furnace or flue
- **Heater temperature drop alarm output (ejector):**
Alarm output when below 100 °C
Mechanical thermostat
1a contact AC 200V 2A

8.1.3 Converter specification (ZKM)

- **Concentration value indication:**
Digital indication in 4 digits
- **Contact output signal:**
(1) Contact specification; 6 points, 1a 250V AC/3A or 30V DC/3A
(2) Contact function;
 - Under maintenance
 - Under blowdown Note3)
 - Span calibrating gas
 - Zero calibration gas
 - Instrument anomalies Note1)
 - Alarm Note2)
- Note1) The following Instrument errors (1) Thermocouples break (2) Sensor break (3) Temperature fault (4) Calibration fault (5) Zero/span adjustment fault (6) Output error turn the contact-ON
- Note2) Alarm selects just one as mentioned below (1) High (2) Low (3) High and Lower (4) High-high (5) Low-low, it turns ON while operating.
- Note3) It is enable during blowdown when an option is specified, and it turns ON while operating.
- **Contact input signal:**
(1) Contact specification; 3points (the following option)
ON; 0V (10mA or less), OFF; 5V
(2) Contact function;
 - External hold
 - Calculation reset

-
- Heater OFF
 - Blow down (option)
 - Inhibition of calibration
 - Calibration start
 - Range change
 - **Calibration method:**
 - (a) Manual calibration with key operation
 - (b) Auto. calibration (option)
Calibration cycle; 00 day 00 hour to 99 days 23 hours
 - (c) All calibration
 - **Calibration gas:**
 - Range settings
Zero gas; 0.010 to 25.00% O₂
Span gas: 0.010 to 50.00% O₂
 - Recommended calibration gas concentration
Zero gas; 0.25 to 2.0% O₂
Span gas; 20.6 to 21.0% O₂
(oxygen concentration in the air)
 - **Blowdown : (option)**
 - A function for blowing out dust with compressed air that has deposited in the flow guide tube. Blowdown can be performed for a predetermined time and at predetermined intervals.
 - Blowdown cycle; 00 hour 00 minute to 99 hours 59 minutes
 - Blowdown time; 0 seconds to 999 seconds
 - **Output hold:**
 - Output can be held during manual calibration, auto calibration, blowdown, sensor recovery process, warm-up. And the hold release function can be available.
 - **Cock(option):**
 - Selects zero or span gas during manual zero or span calibration. Mounted on the side of the converter.
 - **Communication function:**
 - RS232C (MODBUS) standard specification
 - RS485 (MODBUS)(option)
 - **Combustion efficiency display (option):**
 - When you select this display, "rich mode display" will be an simultaneous display.
 - This function calculates and displays combustion efficiency from oxygen concentration and measured gas temperature.
 - Thermocouple (R) is required for temperature measurement.
 - **Operating temperature:**
 - 20 to +55°C
 - **Operating humidity:**
 - 95% RH or less, non condensing
 - **Storage temperature:**
 - 30 to +70°C
 - **Storage humidity:**
 - 95% RH or less, non condensing
 - **Construction:**
 - Dust-proof, rainproof construction (corresponding to IP66 or IP67 of IEC)
 - **Material:**
 - Aluminume case
 - **Outer dimensions (H x W x D):**
 - 170 X 159 X 70mm (IP66)
 - 220 X 230 X 95mm (IP67)
 - **Mass {weight}:**
 - IP66: Approx. 2kg (excluding cable and detector)
 - IP67: Approx. 4.5kg (excluding cable and detector)
 - **Finish color:**
 - Small case (IP66):
Case: Silver
Cover: Pantone Cool Gray IC-F
 - Large case (IP67):
Case: Munsell 6PB 3.5/10.5 (blue)
Cover: Silver
 - **Mounting method:**
 - Panel mounting or pipe mounting
-

8.2 Designation of type (code table)

8.2.1 Detector

1	2	3	4	5	6	7	8	9	10	11	12	13	14	15	16	Description	
Z	F	K	8	R			5								1		Cal. gas inlet
					1												For ϕ 6mm tube (SUS)
					2												For ϕ 1/4 inch tube (SUS)
					3												Ball valve
																	Power supply
					1												100 to 120VAC 50/60Hz
					3												200 to 240VAC 50/60Hz 
																	Flow guide tube
																	flange application length
																	None
																	0 Y 0
																	5 A 3
																	SUS304 general use 300mm
																	5 A 5
																	SUS304 general use 500mm
																	5 A 7
																	SUS304 general use 750mm
																	5 A 1
																	SUS304 general use 1000mm
																	5 B 3
																	SUS316 for corrosive gas 300mm
																	5 B 5
																	SUS316 for corrosive gas 500mm
																	5 B 7
																	SUS316 for corrosive gas 750mm
																	5 B 1
																	SUS316 for corrosive gas 1000mm
																	5 C 3
																	SUS316 with blow-down nozzle 300mm
																	5 C 5
																	SUS316 with blow-down nozzle 500mm
																	5 C 7
																	SUS316 with blow-down nozzle 750mm
																	5 C 1
																	SUS316 with blow-down nozzle 1000mm
																	6 D 8
																	SUS316 for high particulate 800mm
																	6 E 8
																	SUS316 for high particulate with cover 800mm
																	Z Z Z
																	Others Others Others
																	Note) Standard flange size is JIS5K-65A FF, but flange size for high particulate is JIS5K-80A FF
																	Heat insulating cover
																	Without
																	With
																	Reference gas inlet
																	Non
																	For ϕ 6mm tube (SUS)
																	For ϕ 1/4 inch tube (SUS)
																	Filter spec.
																	Standard
																	Instruction manual language
																	Japanese
																	English
																	Chinese
																	Specification name plate
																	Standard (100 to 120V AC 50/60Hz)
																	Standard (200 to 240V AC 50/60Hz)

8.2.2 Replacement sensor unit

Power supply	Code symbols
100 to 120V AC	ZFK8YY15-0Y0YY-0YY
200 to 240V AC	ZFK8YY35-0Y0YY-0YY

8.2.3 Ejector

1	2	3	4	5	6	7	8	Description	
Z	T	A		1			1		Measured gas temperature
				1					For high temperatures (+1500°C max.)
				2					General-use (+800°C max.)
									Insertion length [mm]
								B	500
								C	750
								D	1000
								E	1500
									Power supply
								1	100V/115V AC 50/60Hz
								3	200V/220V AC 50/60Hz
								5	230VAC 50/60Hz

8.2.4 Converter

(1) ZKM

1	2	3	4	5	6	7	8	9	10	11	12
Z	K	M						1			1
Description											
Structure											
1											
2											
3											
Output signal											
B											
E											
Z											
Communication function											
1											
2											
Mounting bracket											
Y											
1											
2											
Optional Functions											
Y											
1											
2											
3											
4											
5											
6											
7											
Display language											
J											
E											
C											
Option											
Y											
1											
2											

Note4) When you select this display, rich mode will be a simultaneous display.

(2) Exclusive cable for converter

1	2	3	4	5	6	7	8	9
Z	R	Z	K	R				
Description								
Connectable devices								
K								
Types								
R								
Conduit length Cable length								
YA								
YB								
YC								
YD								
YE								
YF								
YG								
YH								
YJ								
YK								
YL								
YM								
AA								
BB								
CC								
DD								
Terminal treatment								
0								
1								
2								

Note5) For connection between detector and converter, the conduit to be used should be rainproof flexible type.

8.3 Device composition

The device to be combined differ according to the conditions of the gas to be measured. Select the devices to be combined with reference to the following table.

Application	Temperature	Gas Flow	Measured gas			Device configuration		
			DUST	Protection cover	Note	Detector type	Converter type	Ejector type
General-use (boiler)	600°C or less	5 to 20m/s	Less than 0.2g/Nm ³	—	Fuel; gas, oil	ZFK8R□□5-5A□□□	ZKM	—
			Less than 10g/Nm ³	—	Fuel: coal with blow down	ZFK8R□□5-5C□□□	ZKM	—
For corrosive gas (refuse incinerator)	600°C or less	5 to 20m/s	Less than 1g/Nm ³	—	Included low moisture	ZFK8R□□5-5B□□□	ZKM	—
			Less than 10g/Nm ³	—	Included low moisture with blow down	ZFK8R□□5-5C□□□	ZKM	—
			Less than 25g/Nm ³	no	Included low moisture with blow down	ZFK8R□□5-6D□□□	ZKM	—
Sludge incinerator			Less than 25g/Nm ³	yes	Included high moisture with blow down	ZFK8R□□5-6E□□□	ZKM	—
General-use (furnace)	800°C or less	1m/s or less	Less than 1g/Nm ³	—	When a measurement gas has a low water content with blow down	ZFK8R□□5-0Y0□□	ZKM	ZTA2
	1500°C or less	1m/s or less	Less than 1g/Nm ³	—	When a measurement gas has a low water content with blow down	ZFK8R□□5-0Y0□□	ZKM	ZTA1

Note (1) Dust volume is approximate value.

(2) Instrument quality air or bottled air is available as Reference gas by selecting detector with Reference gas inlet.

8.4 Outline diagram (unit: mm)

(1) Detector (ZFK8)

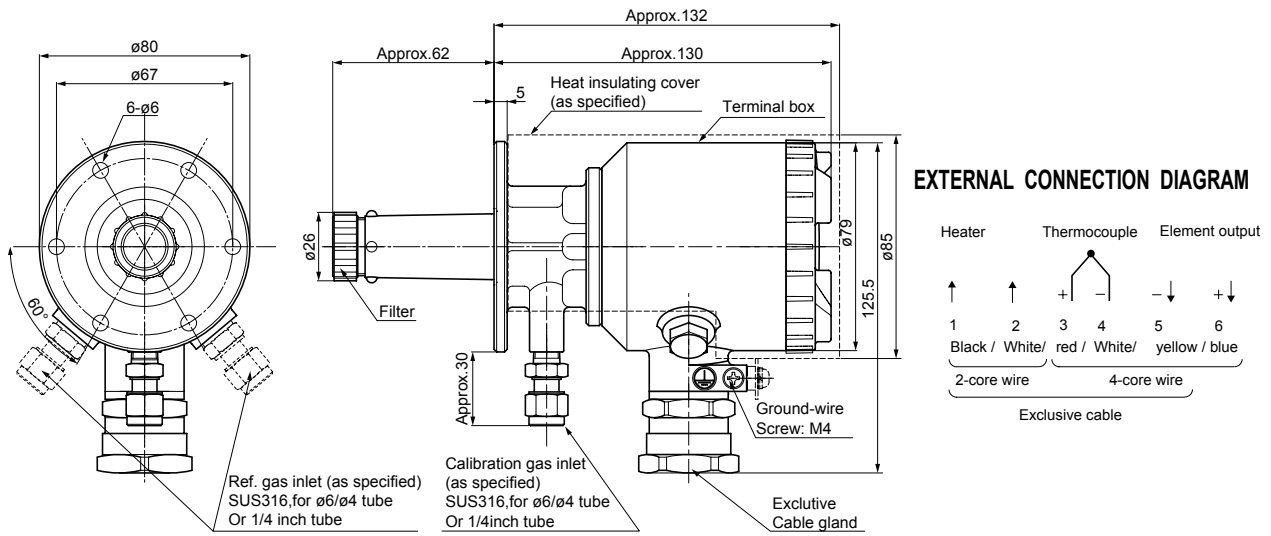

(2) Replacement sensor unit

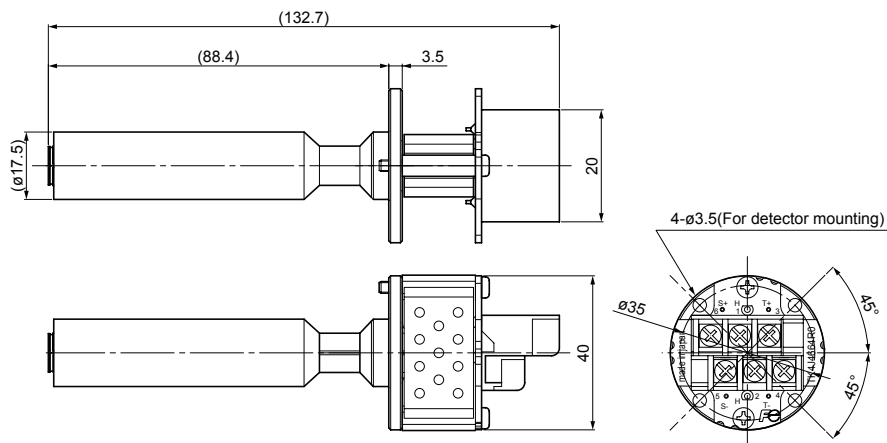

(3) Flow guide tube (for general use)

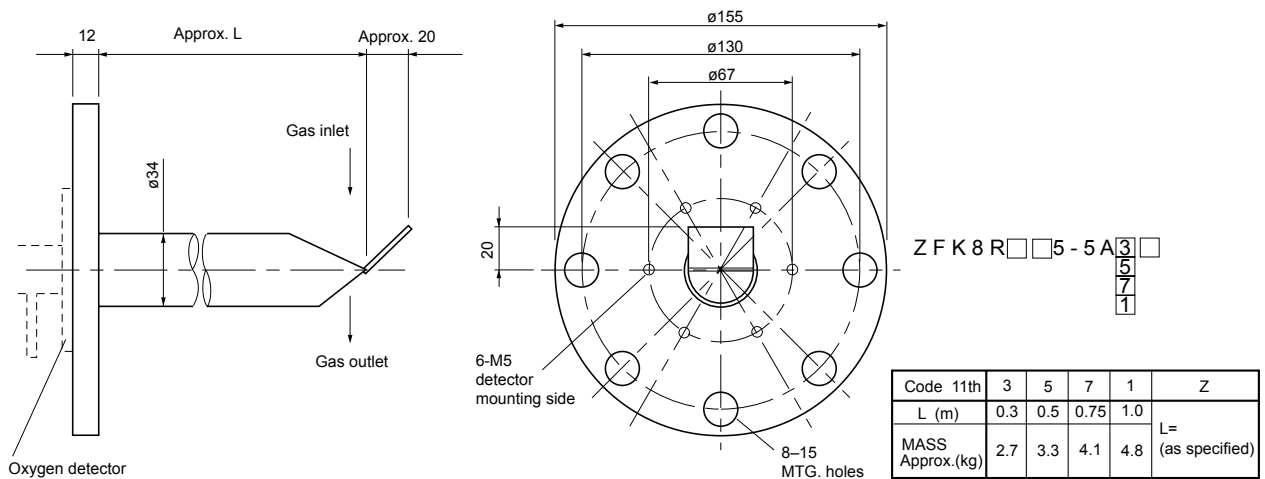

(4) Flow guide tube (For corrosive gas)

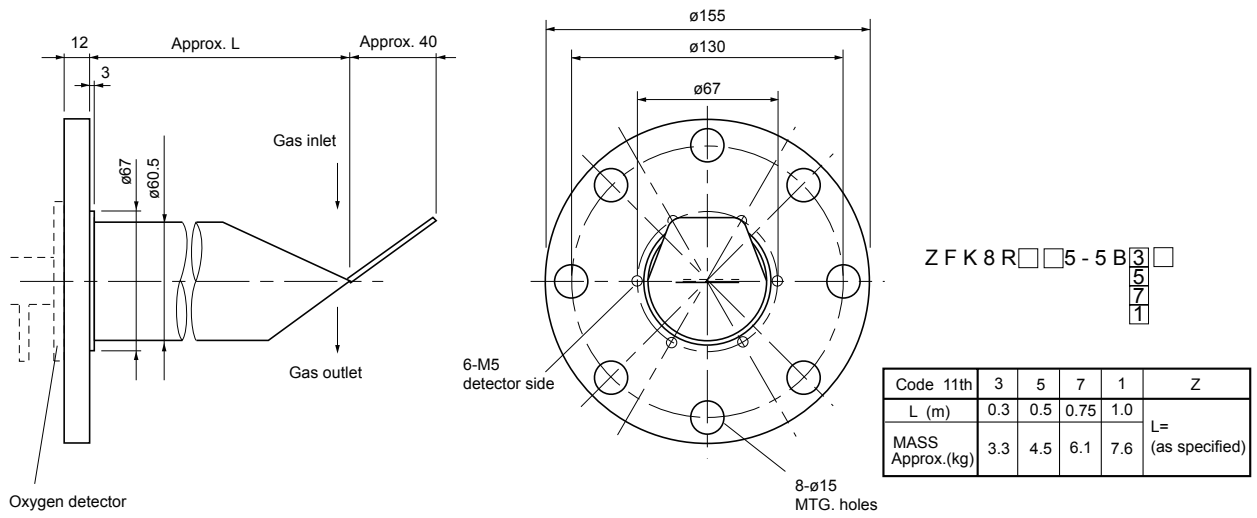

(5) Flow guide tube (with blow down nozzle)

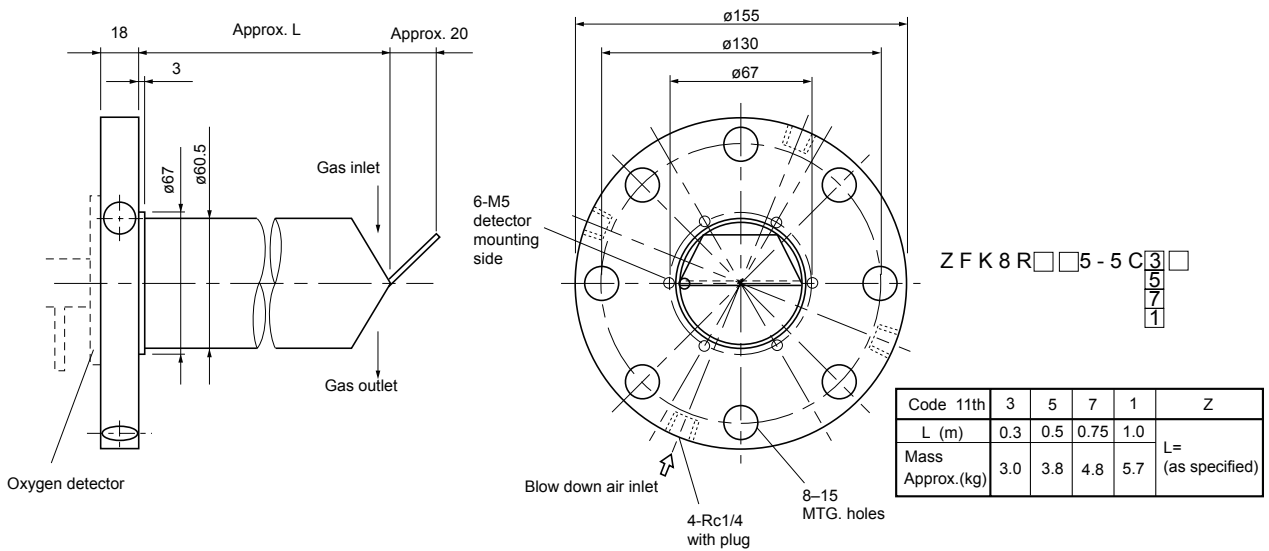

(6) Flow guide tube (for high particulate)

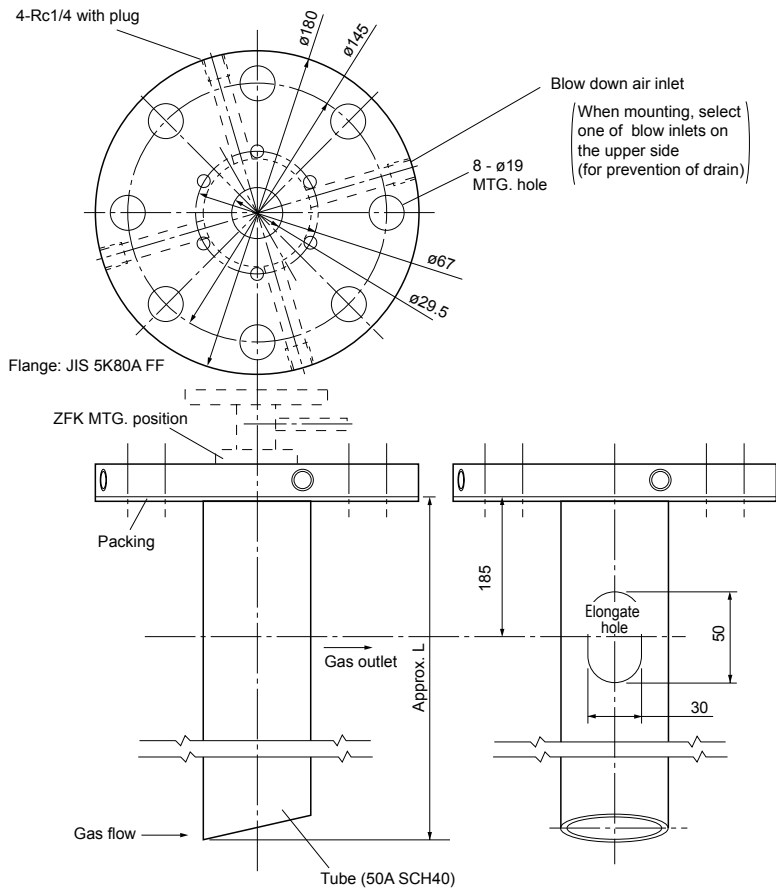

Z F K 8 R □ □ 5 - 6 D 3 □
 □
 5
 7
 1

Code 11th	3	5	7	1	Z
L (m)	0.3	0.5	0.75	1.0	L=
Mass Approx.(kg)	4.5	5.6	7.0	8.3	(as specified)

(7) Flow guide tube (for high particulate with cover)

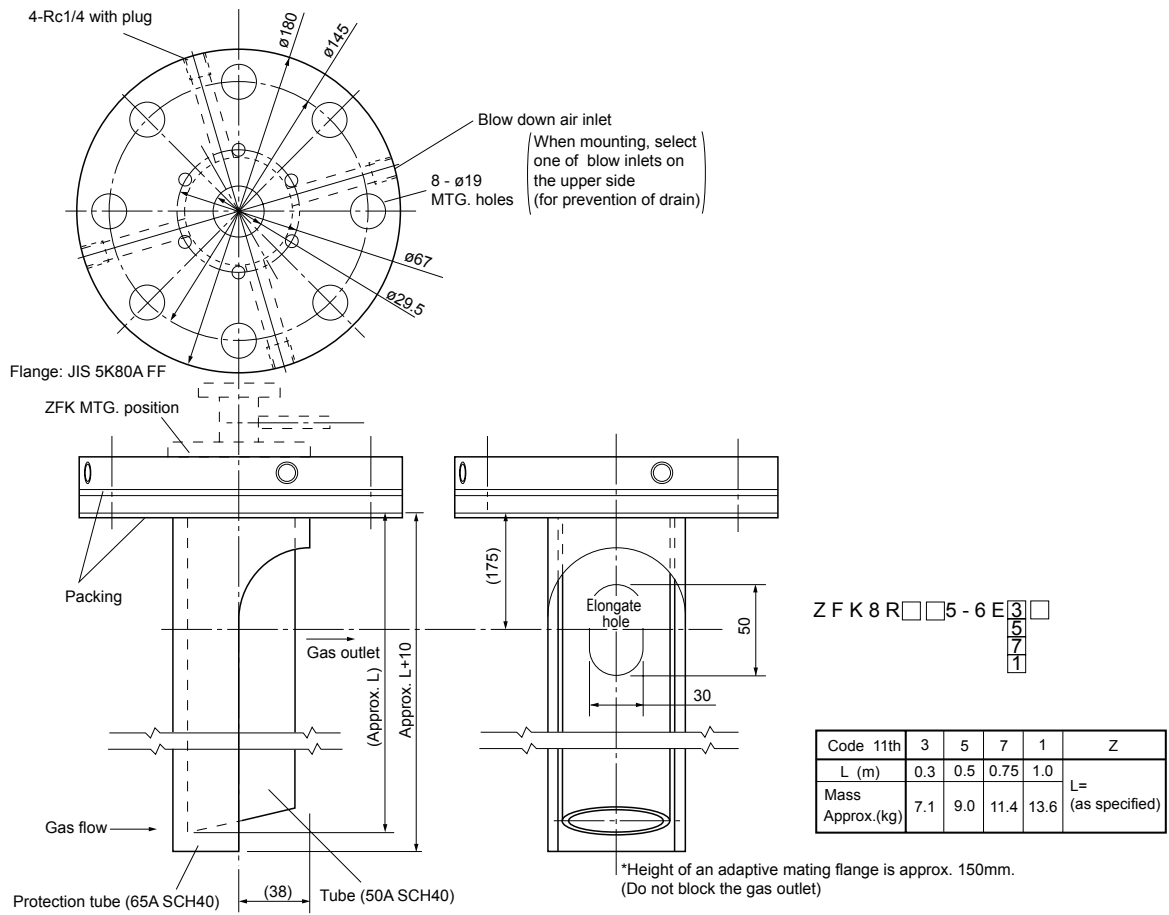

Fuji Electric Co., Ltd.

International Sales Div

Sales Group

Gate City Ohsaki, East Tower, 11-2, Osaki 1-chome,
Shinagawa-ku, Tokyo 141-0032, Japan

<http://www.fujielectric.com>

Phone: 81-3-5435-7280, 7281 Fax: 81-3-5435-7425

<http://www.fujielectric.com/products/instruments/>
