

FRENIC-Multi

CC-Link Interface Option "OPC-E1-CCL"

CAUTION

Thank you for purchasing our CC-Link Interface Card OPC-E1-CCL.

- This product is designed to connect the FRENIC-Multi series of inverters to CC-Link network. Read through this instruction manual in conjunction with the FRENIC-Multi User's Manual and be familiar with the handling procedure for correct use.
- Improper handling blocks correct operation or causes a short life or failure.
- Deliver this manual to the end user of the product. The end user should keep this manual in a safe place until the CC-Link Interface Option is discarded.
- For the usage of inverters, refer to the instruction manual prepared for the FRENIC-Multi series of inverters.

Copyright © 2006 Fuji Electric FA Components & Systems Co., Ltd.

All rights reserved.

No part of this publication may be reproduced or copied without prior written permission from Fuji Electric Systems Co., Ltd.

All products and company names mentioned in this manual are trademarks or registered trademarks of their respective holders.

The information contained herein is subject to change without prior notice for improvement.

Preface

Thank you very much for purchasing our CC-Link Interface Option "OPC-E1-CCL."

This manual has been prepared to help you connect your FRENIC-Multi to a CC-Link master (Mitsubishi Electric sequencer, etc.) via CC-Link.

Mounting this option on your FRENIC-Multi allows you to connect the FRENIC-Multi to a CC-Link master and control it as a slave using run command, speed command, and access to inverter's function codes.

This option has the following features:

- CC-Link Version: Complies with CC-Link versions 1.10 and 2.00
- Applicable Profile: Inverter (1 station occupied)
- Monitoring the status of the FRENIC-Multi (running status, frequency, output torque, output current, output voltage and etc.)
- Reading and writing from/to function codes applicable to the FRENIC-Multi



This option is a CC-Link version 2.00 compliant remote device unit and supports the following:

- Extended cyclic transmission
- Easing restrictions on inter-station cable length

This instruction manual does not contain inverter handling instructions. Read through this instruction manual in conjunction with the FRENIC-Multi Instruction Manual (INR-SI47-1204-E) and be familiar with proper handling and operation of this product. Improper handling might result in incorrect operation, a short life, or even a failure of this product.

Keep this manual in a safe place.

Related Publications

Listed below are the other materials related to the use of the CC-Link Interface Option "OPC-E1-CCL." Read them in conjunction with this manual as necessary.



- RS-485 Communication User's Manual (MEH448)
- FRENIC-Multi Instruction Manual (INR-SI47-1204-E)

The materials are subject to change without notice. Be sure to obtain the latest editions for use.

Safety precautions

Read this manual thoroughly before proceeding with installation, connections (wiring), operation, or maintenance and inspection. Ensure you have sound knowledge of the device and familiarize yourself with all safety information and precautions before proceeding to operate the inverter.

Safety precautions are classified into the following two categories in this manual.

 WARNING	Failure to heed the information indicated by this symbol may lead to dangerous conditions, possibly resulting in death or serious bodily injuries.
 CAUTION	Failure to heed the information indicated by this symbol may lead to dangerous conditions, possibly resulting in minor or light bodily injuries and/or substantial property damage.

Failure to heed the information contained under the CAUTION title can also result in serious consequences. These safety precautions are of utmost importance and must be observed at all times.

Installation and wiring

WARNING

- Turn the inverter's power OFF and wait for at least five minutes. Further, check that the DC link bus voltage between the P (+) and N (-) terminals is lower than 25 VDC.
- Qualified electricians should carry out wiring.
Otherwise, electric shock could occur.

CAUTION

- Do not use the products that are damaged or lacking parts.
Doing so could cause a fire, accident, or injury.
- Prevent lint, paper fibers, sawdust, dust, metallic chips, or other foreign materials from getting into the inverter and the option.
Otherwise, a fire or an accident might result.
- Incorrect handling in installation/removal jobs could cause a failure.
A failure might result.
- Noise may be emitted from the inverter, motor and wires. Implement appropriate measure to prevent the nearby sensors and devices from malfunctioning due to such noise.
Otherwise, an accident could occur.

Operation

WARNING

- Be sure to mount the inverter's and option's terminal covers before turning the inverter's power ON. Do not remove the covers while power is applied.
Otherwise electric shock could occur.
- Do not operate switches with wet hands.
Doing so could cause electric shock.
- If you configure the function codes wrongly or without completely understanding FRENIC-Multi Instruction Manual (INR-SI47-1204-E) and the FRENIC-Multi User's Manual (MEH457), the motor may rotate with a torque or at a speed not permitted for the machine. Confirm and adjust the setting of the function codes before running the inverter.
Otherwise, an accident could occur.

Maintenance and inspection, and parts replacement

WARNING

- Turn the inverter's power OFF and wait for at least five minutes before starting inspection. Further, check that the DC link bus voltage between the P (+) and N (-) terminals is lower than 25 VDC.
Otherwise, electric shock could occur.
- Maintenance, inspection, and parts replacement should be made only by qualified persons.
- Take off the watch, rings and other metallic objects before starting work.
- Use insulated tools.
Otherwise, electric shock or injuries could occur.

Disposal

CAUTION

- Treat the product as an industrial waste when disposing of it.
Otherwise injuries could occur.

Others

WARNING

- Never attempt to modify the product.
Doing so could cause electric shock or injuries.

How this manual is organized

This manual is made up of chapters 1 through 12.

Chapter 1 BEFORE USING THE CC-Link INTERFACE OPTION

Lists points to be checked upon delivery of this option and describes the applicable inverters.

Chapter 2 NAMES AND FUNCTIONS

Shows the inside view of this option and describes the terminating resistor switch and LED status indicators.

Chapter 3 MOUNTING THE CC-Link INTERFACE OPTION

Provides instructions and precautions for mounting this option.

Chapter 4 WIRING AND CABLING

Provides wiring instructions around the terminal blocks on this option and the cable specifications.

Chapter 5 CONFIGURING INVERTER'S FUNCTION CODES FOR CC-Link COMMUNICATION

Describes the inverter's function codes to be set for the CC-Link communications link. Also this chapter lists the related function codes.

Chapter 6 SETTING-UP PROCEDURE

Guides you to establish a CC-Link communications link.

Chapter 7 LIST OF I/O SIGNALS

Provides the details of remote I/O signals available for CC-Link communication.

Chapter 8 INVERTER REACTION TO CC-Link COMMUNICATIONS ERRORS

Describes on how the inverter operates if a CC-Link communications error occurs.

Chapter 9 ALARM CODE LIST

Lists and describes inverter's alarm codes.

Chapter 10 APPLICATION PROGRAM EXAMPLES

Provides program examples that control the inverter by a sequencer.

Chapter 11 TROUBLESHOOTING

Provides troubleshooting instructions for certain problems, e.g., when the inverter does not operate as ordered or when an alarm condition has been recognized.

Chapter 12 SPECIFICATIONS

Lists the general specifications and communications specifications.

Icons

The following icons are used throughout this manual.



This icon indicates information which, if not heeded, can result in the product not operating to full efficiency, as well as information concerning incorrect operations and settings which can result in accidents.



This icon indicates information that can prove handy when performing certain settings or operations.

This icon indicates a reference to more detailed information.

Table of Contents

Preface	1	Chapter 8 .. INVERTER REACTION TO CC-Link COMMUNICATIONS ERRORS	29
How this manual is organized	3		
Chapter 1 BEFORE USING THE CC-Link INTERFACE OPTION.....	5	Chapter 9 LIST OF INVERTER ALARM CODES	30
1.1 Acceptance Inspection	5	Chapter 10 APPLICATION PROGRAM EXAMPLES.....	31
Chapter 2 NAMES AND FUNCTIONS	6	10.1 System Configuration.....	31
2.1 Parts Names	6	10.2 Network Parameter Settings	31
2.2 Terminating Resistor Switch	6	10.3 Relationship between Master Station Device and Remote I/O and Remote Register.....	32
2.3 LED Status Indicators.....	7	10.4 CC-Link Startup Program.....	33
2.4 RJ-45 Connector	8	10.5 Program Example Using the Inverter Running Status Read	33
2.5 Power Supply Terminal Block and CC-Link Terminal Block.....	8	10.6 Program Example for Changing the Operation Mode.....	34
Chapter 3 MOUNTING THE CC-Link INTERFACE OPTION.....	9	10.7 Program Example for Specifying Run Command.....	34
Chapter 4 WIRING AND CABLING.....	13	10.8 Program Example for Monitoring the Output Frequency.....	35
4.1 Basic Connection Diagram.....	13	10.9 Program Example for Reading from the Inverter's Function Code Data	35
4.2 Wiring for Power Supply Terminal Block.....	14	10.10 Program Example for Writing to Inverter's Function Code Data	36
4.3 Wiring for CC-Link Terminal Block.....	15	10.11 Program Example for Setting up the Reference Frequency.....	37
4.4 ON/OFF Timing of the Option and the Inverter.....	17	10.12 Program Example for Reading out Alarm Codes ..	38
Chapter 5 CONFIGURING INVERTER'S FUNCTION CODES FOR CC-Link COMMUNICATION	18	10.13 Program Example for Resetting a Inverter Trip.....	38
Chapter 6 SETTING-UP PROCEDURE.....	19	Chapter 11 TROUBLESHOOTING.....	39
Chapter 7 LIST OF I/O SIGNALS.....	20	Chapter 12 SPECIFICATIONS	40
7.1 Remote I/O Signals	20	12.1 General Specifications	40
7.2 Remote Registers	22	12.2 CC-Link Specifications.....	40
7.3 List of Monitor Item Codes	26		
7.4 Command Codes and Response Codes.....	27		

Chapter 1 BEFORE USING THE CC-Link INTERFACE OPTION

1.1 Acceptance Inspection

Unpack the package and check the following:

(1) A CC-Link interface option and the following accessories are contained in the package. (See Figure 1.1.)

-Two option connection cables (A short one for inverters with a capacity of 5 HP or below and a long one for inverters with a capacity of 7.5 HP or above)

-One option fixing screw

-CC-Link Interface Option Instruction Manual (this manual)

(2) The option and accessories have not been damaged during transportation—there should be no dents or parts missing.

(3) The model name "OPC-E1-CCL" is printed on the nameplate attached to the right side of the option. (See Figure 1.1.)

If you suspect the product is not working properly or if you have any questions about your product, contact your Fuji Electric representative.

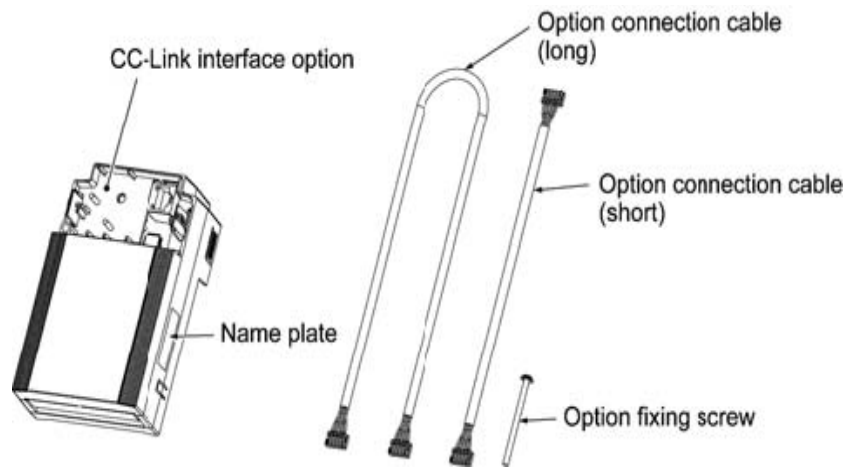

Figure 1.1 CC-Link Interface Option and Accessories

Chapter 2 NAMES AND FUNCTIONS

2.1 Parts Names

Figure 2.1 shows the inside view of the CC-Link interface option with its terminal cover (See Figure 3.3) removed.

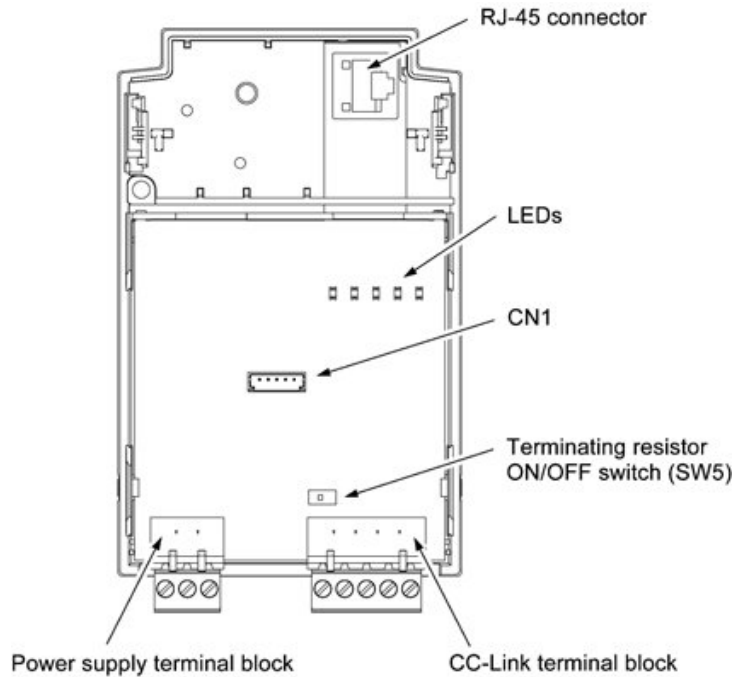

Figure 2.1 Parts Names of CC-Link Interface Option

2.2 Terminating Resistor Switch

The CC-Link communications network requires insertion of line terminating resistors at its both ends. When this option is mounted on the inverter at either end of the network, turn this switch ON to insert the terminating resistor.

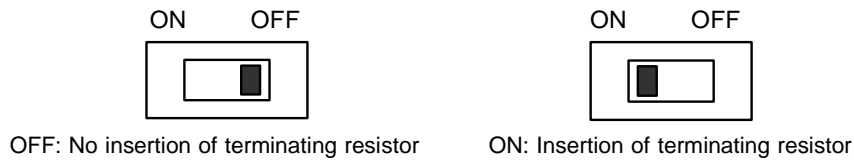

Figure 2.2 Terminating Resistor Switch Settings

2.3 LED Status Indicators

This option has five LED status indicators shown below. They indicate the operation status of the option as listed in Table 2.1.



Figure 2.3 LED Status Indicators

Table 2.1 LED Indications and Operation Status

LED States					Operation Status
L.RUN	RUN	L.ERR	SD	RD	
					Normally communicating.
					Normally communicating. But sometimes a CRC error occurs due to electrical noise.
					Received data contains a CRC error, so this option cannot respond.
					Data destined for this station does not come.
					Responding to polling. But refresh data received contains a CRC error. The inverter trips with alarm displayed. *1
					Data destined for this station contains a CRC error. The inverter trips with alarm displayed. *1
					Station address incorrectly specified. Data destined for this station cannot be received due to electrical noise.
					Transmission speed (Baud rate) and/or station address out of the allowable range.
		(at 0.8-second intervals)			Transmission speed (Baud rate) or station address changed during CC-Link communication.
					This option cannot receive data due to broken wires, etc. The inverter trips with alarm displayed. *1
	(at 0.4-second intervals)				The master station is compliant with CC-Link version 1.xx and this slave station, with CC-Link version 2.xx. Or the inverter's function code o30 is set to "5 to 255." The inverter trips with alarm displayed.
	(at 0.2-second intervals)				During normal communication, the option connection cable has been broken or the power to the inverter has been cut OFF. If the cable has been broken, the inverter trips with alarm displayed.
	(at 50 ms intervals)				When this option is turned ON, the inverter has been OFF or the option connection cable has been disconnected.
					This option is OFF or broken. If the inverter power is ON, it trips with alarm displayed.

: ON, : OFF, Blinking (It may seem to be ON depending on the current transmission speed.)

*1 Alarm occurs when a communications error is detected after a normal communications link has been established once.

It is possible to change the occurrence conditions with inverter's function codes. For details, refer to Chapter 8 "INVERTER REACTION TO CC-Link COMMUNICATIONS ERRORS."

2.4 RJ-45 Connector

The RJ-45 connector is used to connect the keypad of the FRENIC-Multi to this option.

The keypad can be detached from the option and mounted on a panel. For details, refer to the FRENIC-Multi Instruction Manual (INR-SI47-1204-E), Chapter 2, Section 2.4 "Mounting and Connecting a Keypad."

2.5 Power Supply Terminal Block and CC-Link Terminal Block

The power supply terminal block and CC-Link terminal block are used to connect the 24V power cable and CC-Link cable, respectively, in order to operate this option.

For details, refer to Chapter 4 "WIRING AND CABLING."

Chapter 3 MOUNTING THE CC-Link INTERFACE OPTION

WARNING

Turn the inverter's power OFF and wait for at least five minutes. Further, check that the DC link bus voltage between the P (+) and N (-) terminals is lower than 25 VDC.

Otherwise, electric shock could occur.

CAUTION

- Do not use the products that are damaged or lacking parts.
Doing so could cause a fire, accident, or injury.
- Prevent lint, paper fibers, sawdust, dust, metallic chips, or other foreign materials from getting into the inverter and the option.
Otherwise, a fire or an accident might result.
- Incorrect handling in installation/removal jobs could cause a failure.
- When handling this option, take any antistatic measure or hold the plastic parts taking care not to directly touch the circuit board; otherwise, the static electricity charged in your body may damage it.
A failure might result.



Before mounting the option, perform the wiring for the main circuit terminals and control circuit terminals.

- (1) Remove the terminal cover from the inverter.

Note: For inverters with a capacity of 7.5 to 20 HP, you need to remove the terminal cover fixing screw to remove the terminal cover.

For details on how to remove the terminal cover, refer to the FRENIC-Multi Instruction Manual (INR-SI47-1204-E), Chapter 2, Section 2.3 "Wiring."

- (2) Connect the option connection cable to the CN1 connector on the interface printed circuit board (interface PCB) on the inverter.

Use the short cable for inverters with a capacity of 5 HP or below, and the long cable for the ones with a capacity of 7.5 HP or above.

- (3) Mount the terminal cover.

For details on how to mount the terminal cover, refer to the FRENIC-Multi Instruction Manual (INR-SI47-1204-E), Chapter 2, Section 2.3 "Wiring."

- (4) Push the hooks provided on both sides of the keypad and pull the keypad up and out of the inverter.

For details on how to remove the keypad, refer to the FRENIC-Multi Instruction Manual (INR-SI47-1204-E), EChapter 2, Section 2.4 "Mounting and Connecting a Keypad."

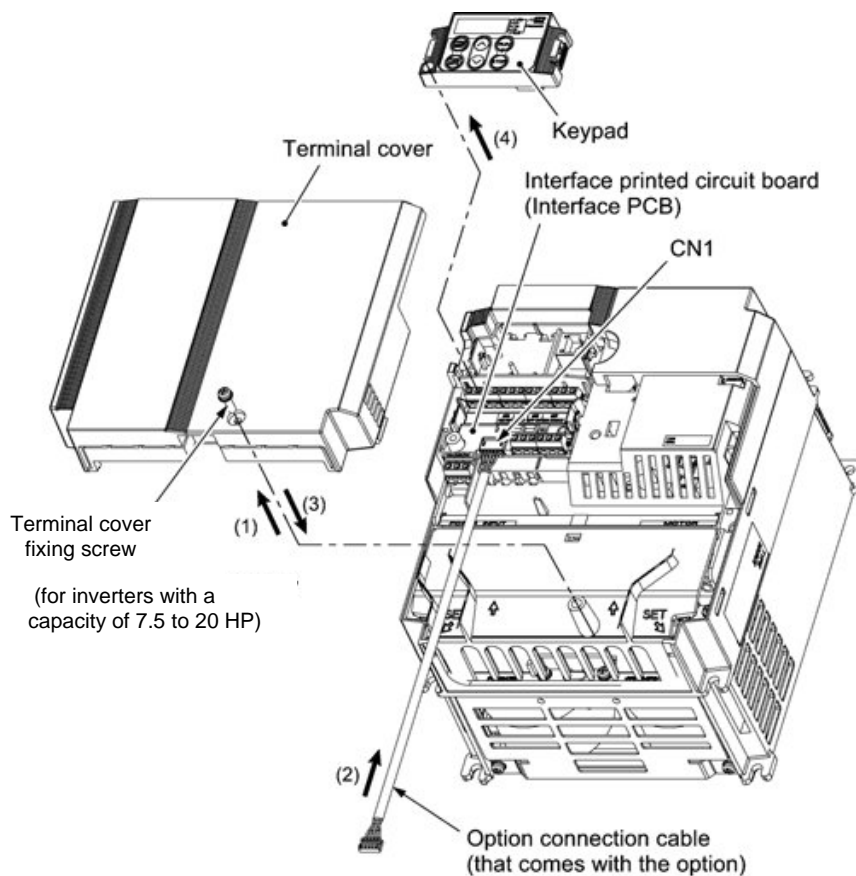

Figure 3.1 Connecting the Option Connection Cable to the Interface PCB and Removing the Keypad
(For inverters with a capacity of 15 and 20 HP)

- (5) Mount the option on the inverter, making the RJ-45 connector on the back side of the option engage with the RJ-45 connector on the inverter (to which the keypad had been connected).
- (6) Connect the keypad to the RJ-45 connector on the front side of the option, then secure the keypad and option to the inverter with the option fixing screw (that comes with the option).

When using the keypad at a remote site, secure the option without the keypad to the inverter with the screw.

Tightening torque: 0.6 N·m(0.44 lbf·ft)

Note Take care not to tighten the option fixing screw too much. Doing so could make the screw defective.

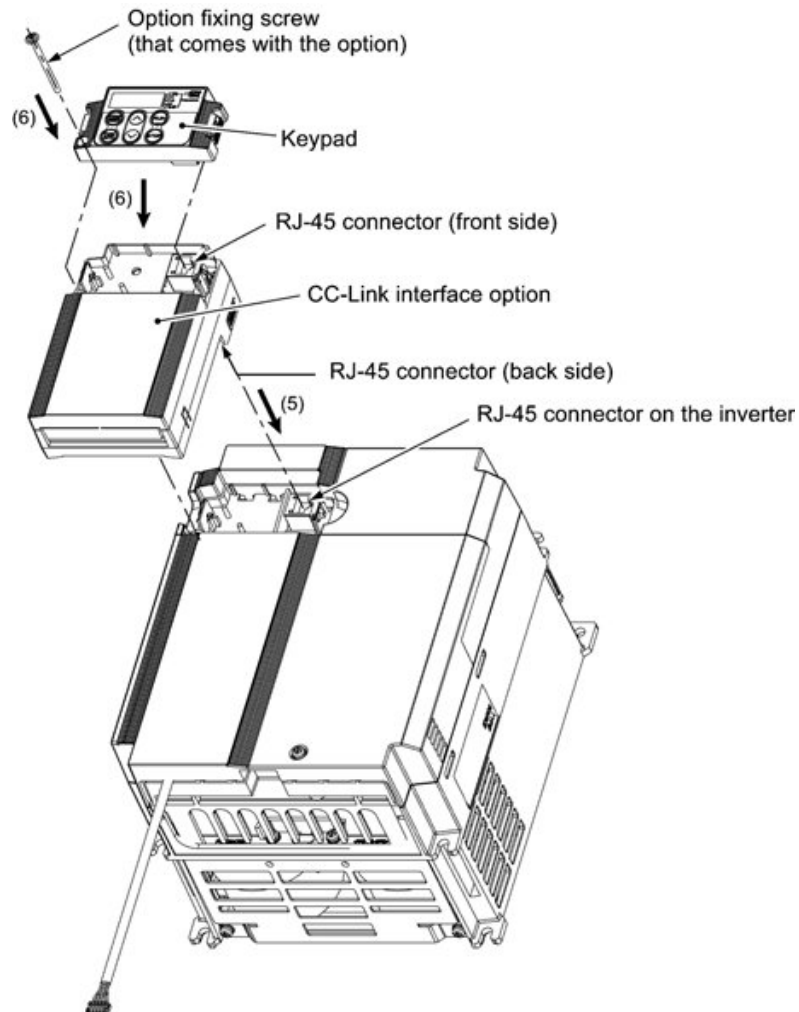

Figure 3.2 Mounting the CC-Link Interface Option and the Keypad

- (7) Slightly pull the bottom of the option terminal cover towards you and remove it downward.
- (8) Connect the other end of the option connection cable (whose end has been connected to the interface PCB on the inverter in step (2) above) to the CN1 connector on the interface option printed circuit board (interface option PCB).
- (9) Mount the option terminal cover.

First fit the bosses on the top of the cover into the square holes provided in the option, and then push the bottom of the cover until it snaps into place.

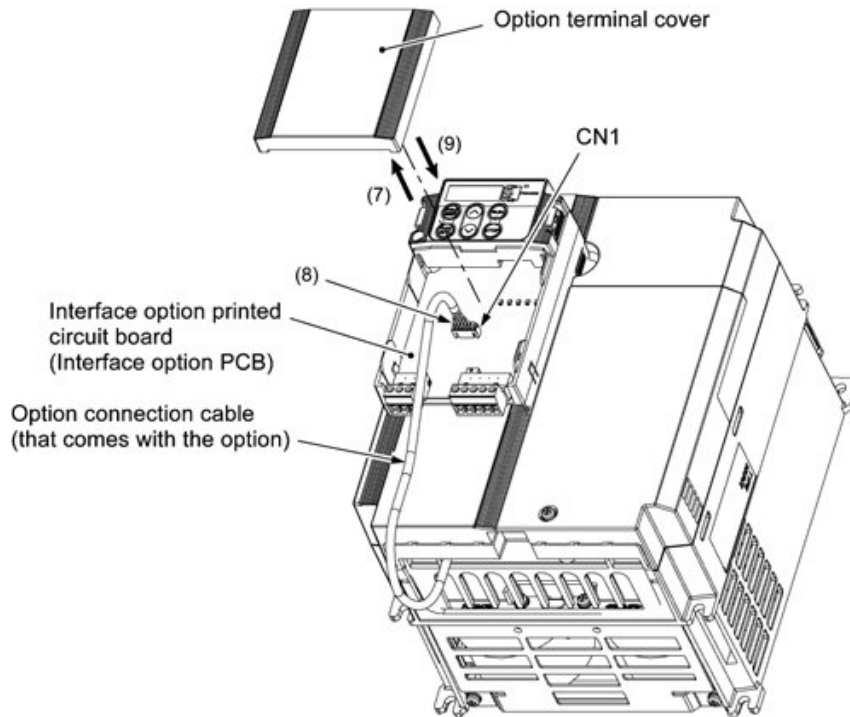

Figure 3.3 Connecting the Option Connection Cable to the Interface Option PCB

Chapter 4 WIRING AND CABLING

⚠ WARNING

- Before starting installation, turn the inverter's power OFF and wait for at least five minutes. Further, check that the DC link bus voltage between the P (+) and N (-) terminals is lower than 25 VDC.
- Qualified electricians should carry out wiring.

Otherwise, electric shock could occur.

⚠ CAUTION

The inverter, motor, and wiring emit electrical noise. Take appropriate measures to prevent the nearby sensors and devices from malfunctioning due to such noise.

Otherwise, an accident could occur.

4.1 Basic Connection Diagram

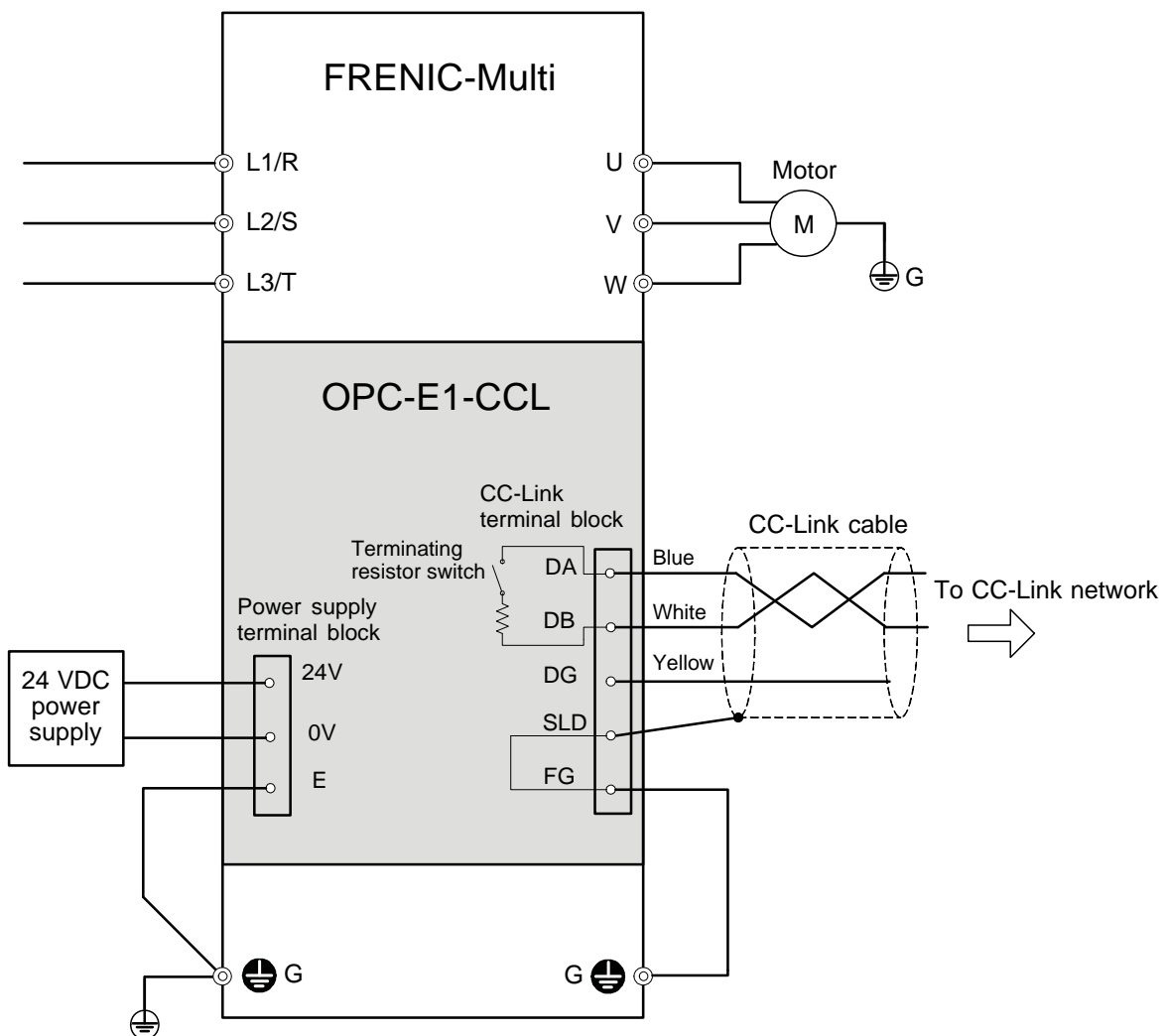

Figure 4.1 Basic Connection Diagram

⚠ CAUTION

For the 24 VDC power supply to be connected to the power supply terminal block, be sure to use an external 24 V power supply with a capacity of at least 150 mA. Never use the PLC terminal on the inverter; doing so flows a current exceeding the capacity of the PLC terminal, resulting in a damaged inverter.

A failure might result.

4.2 Wiring for Power Supply Terminal Block

This terminal block is used to supply this option with 24 V power to operate it. Perform wiring for the terminal block as described below.

⚠ CAUTION

For the 24 VDC power supply to be connected to the power supply terminal block, be sure to use an external 24 V power supply with a capacity of at least 150 mA. Never use the PLC terminal on the inverter; doing so flows a current exceeding the capacity of the PLC terminal, resulting in a damaged inverter.

A failure might result.

(1) Wiring for the power supply terminal block (TERM3)

The terminal block uses a pluggable 3-pin connector as shown in Figure 4.2. Table 4.1 shows the pin assignment.

A typical connector that matches this terminal block is Phoenix Contact MSTB 2.5/3-ST-5.08.

Table 4.1 Pin Assignment on Power Supply Terminal Block

Pin #	Terminal name	Description	Remarks
1	24 V	Power supply (24 VDC, + side)	Never use the PLC terminal on the inverter for 24 V power.
2	0 V	Power supply (24 VDC, - side)	
3	E	Grounding terminal	Connect the ground terminal of the inverter (⚡G) to this terminal.

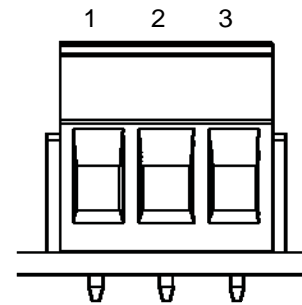

Figure 4.2 Connectors on the Power Supply Terminal Block



Note For protection against external noise and prevention of failures, be sure to connect a grounding wire.

Table 4.2 lists the recommended wire size, terminal screw size and its tightening torque.

Table 4.2 Recommended Wire Size, Terminal Screw Size, and Its Tightening Torque for the Power Supply Terminal Block

Wire size	Terminal screw size	Tightening torque
AWG20 to AWG16 (0.5 to 1.5 mm ²), wire with rated temperature 105 C(221 F) (UL) recommended	M3	0.5 to 0.6 N·m (0.37 to 0.44 lbf·ft)

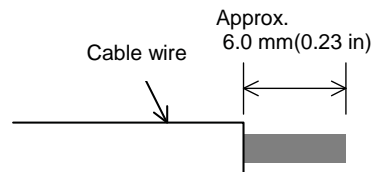

Figure 4.3 Recommended Strip Length of the Cable Wire End for Terminal Connection

(2) Input power requirements

Select the 24 V input power supply that meets the specifications listed in Table 4.3.

Table 4.3 Input Power Requirements

Item	Specifications
Input power voltage range	21.6 to 27.0 V
Power consumption	Maximum 150 mA

4.3 Wiring for CC-Link Terminal Block

- (1) To connect this option to a CC-Link network, use a CC-Link dedicated cable complying with the CC-Link specifications. Using a cable other than a CC-Link dedicated cable does not assure the CC-Link system performance. Also observe the wiring lengths specified in the CC-Link version 1.10 specifications.



The recommended CC-Link cable is FANC-110SBH made by Kuramo Electric Co., Ltd.

For details about wiring for CC-Link, refer to the CC-Link Master Use's Manual or CC-Link Cable Wiring Manual published by the CC-Link Partner Association. The CC-Link Cable Wiring Manual is available as a free download from the CC-Link Partner Association's website at:
http://www.cc-link.org/eng/t_html/siryo.html

- (2) Wiring around the CC-Link terminal block

The terminal block uses a pluggable 5-pin connector as shown in Figure 4.4. Table 4.4 shows the correspondence between the pin numbers and the ID colors.

A typical connector that matches this terminal block is Phoenix Contact MSTB 2.5/5-ST-5.08 AU.



The Phoenix Contact TMSTBP 2.5/5-ST-5.08 AU and TFKC 2.5/5-STF-5.08 AU (spring-cage connection type) connectors for multidrop connection are also usable. Note that, however, the former can be used only for FRENIC-Multi with a capacity of 5 HP or below.

Table 4.4 Layout of Terminal Pins

Terminal Pin Name	ID Color of Wire Sheath	Description	Remarks
DA	Blue	For communication data	
DB	White		
DG	Yellow		
SLD	Metallic	For shielded wire	This is internally connected with terminal FG.
FG	---	For grounding	Connect the ground terminal of the inverter (●G) to this terminal.

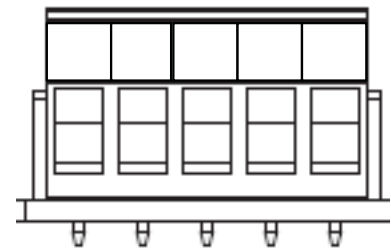

Figure 4.4 Connectors on the CC-Link Terminal Block

Table 4.5 lists the recommended terminal screw size and its tightening torque, and Figure 4.5 shows the recommended strip length of the cable wire end.

Table 4.5 Recommended Tightening Torque of the Terminal Screws on the CC-Link Terminal Block

Terminal screw size	Tightening torque
M3	0.5 to 0.6 N·m(0.37 to 0.44 lbf·ft)

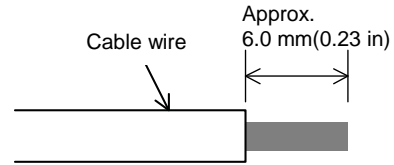

Figure 4.5 Recommended Strip Length of the Cable Wire End for Terminal Connection

(3) When two or more inverters are connected

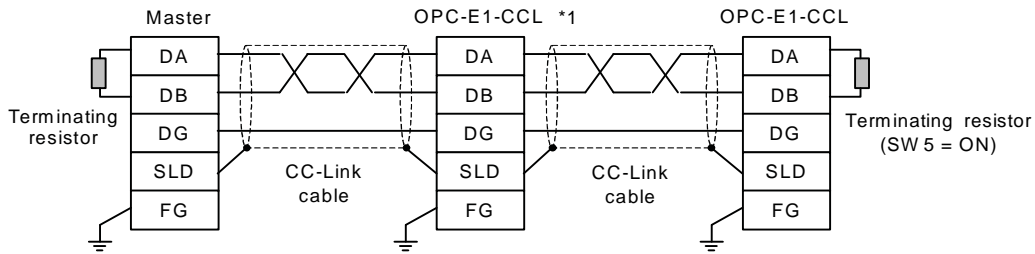

Figure 4.6 Connection Diagram of Two or More Inverters

*1 On CC-Link interface options connected in the middle of the network, set their terminating resistor switches (SW5) to OFF (No insertion of terminating resistor).

4.4 ON/OFF Timing of the Option and the Inverter

Observe the following instructions about the ON/OFF timing of this option and the inverter.

(1) Power ON

It is recommended that this option be turned ON at the same time as or before the inverter. Turning the inverter ON first may detect no operation of the option, causing a trip with alarm. The alarm can be reset after this option is turned ON.

(2) Power OFF

It is recommended that this option be turned OFF at the same time as or after the inverter. Turning the option OFF first may cause the inverter to detect no operation of the option, causing a trip with alarm. Turning the inverter OFF resets the alarm.



The inverter issues an alarm if the option's power stays OFF for approximately 1 second when the inverter power is ON.

Chapter 5 CONFIGURING INVERTER'S FUNCTION CODES FOR CC-Link COMMUNICATION

Before starting CC-Link communication between the inverter equipped with this option and the CC-Link master device, configure the inverter's function codes listed in Table 5.1.

Table 5.2 lists other related function codes to be configured if necessary.

Table 5.1 Inverter's Function Codes for CC-Link Communication
(The underlined values are factory defaults.)

Function code	Function	Setting range	Description
o27 *1	Response mode to apply when a CC-Link communications error occurs	<u>0</u> to 15	Select a response mode to apply when a communications link error or an option failure is detected.
o28 *1	Operation timer to apply when a CC-Link communications error occurs	<u>0.0</u> to 60.0 sec.	Specify the timer period during which the inverter keeps running even if a communications link error is detected.
o30 *2	CC-Link extension	<u>0</u> , 1	1 station occupied (CC-Link version 1.10)
		2	1 station occupied, 2X setting (CC-Link version 2.00)
		3	1 station occupied, 4X setting (CC-Link version 2.00)
		4	1 station occupied, 8X setting (CC-Link version 2.00)
		5 to 255	No operation
o31 *3	Station address	1 to 64	Set a station address.
		<u>0</u> , 65 to 255	Invalid
o32 *3	Transmission speed	<u>0</u>	156 kbps
		1	625 kbps
		2	2.5 Mbps
		3	5 Mbps
		4	10 Mbps
		5 to 255	Invalid

*1 For details about the function codes o27 and o28, refer to Chapter 8 "INVERTER REACTION TO CC-Link COMMUNICATIONS ERRORS."

*2 After changing the o30 data, resetting the option (by turning the terminal RST ON or by turning the option's power OFF and then ON) validates the new setting. However, resetting the option causes an inverter trip with an alarm if Version 1.xx is specified on the master station and Version 2.xx on the option.

*3 Changing the o31 or o32 data causes the L.ERR LED to start blinking. Resetting the option validates the new setting and turns the L.ERR LED OFF.

Table 5.2 Other Related Function Codes

Function code	Function	Factory default	Function code data	Remarks															
y98 *1	Run/frequency command sources	0	Select from the following choices: <table border="1" style="margin-left: 20px;"> <thead> <tr> <th></th> <th>Frequency command</th> <th>Run command</th> </tr> </thead> <tbody> <tr> <td>0</td> <td>Inverter</td> <td>Inverter</td> </tr> <tr> <td>1</td> <td>CC-Link</td> <td>Inverter</td> </tr> <tr> <td>2</td> <td>Inverter</td> <td>CC-Link</td> </tr> <tr> <td>3</td> <td>CC-Link</td> <td>CC-Link</td> </tr> </tbody> </table>		Frequency command	Run command	0	Inverter	Inverter	1	CC-Link	Inverter	2	Inverter	CC-Link	3	CC-Link	CC-Link	If there is no special problem with your system, setting y98 = 3 is recommended.
	Frequency command	Run command																	
0	Inverter	Inverter																	
1	CC-Link	Inverter																	
2	Inverter	CC-Link																	
3	CC-Link	CC-Link																	

*1 In addition to y98, there are some function codes that specify run/frequency command sources. Using those function codes enables more flexible settings of run/frequency command sources. For details, refer to the description for the function codes H30 and y98 in the FRENIC-Multi Instruction Manual (INR-SI47-1204-E), Chapter 5 "FUNCTION CODES."

Chapter 6 SETTING-UP PROCEDURE

The following flow shows the initial setting-up procedure for the CC-Link interface option.

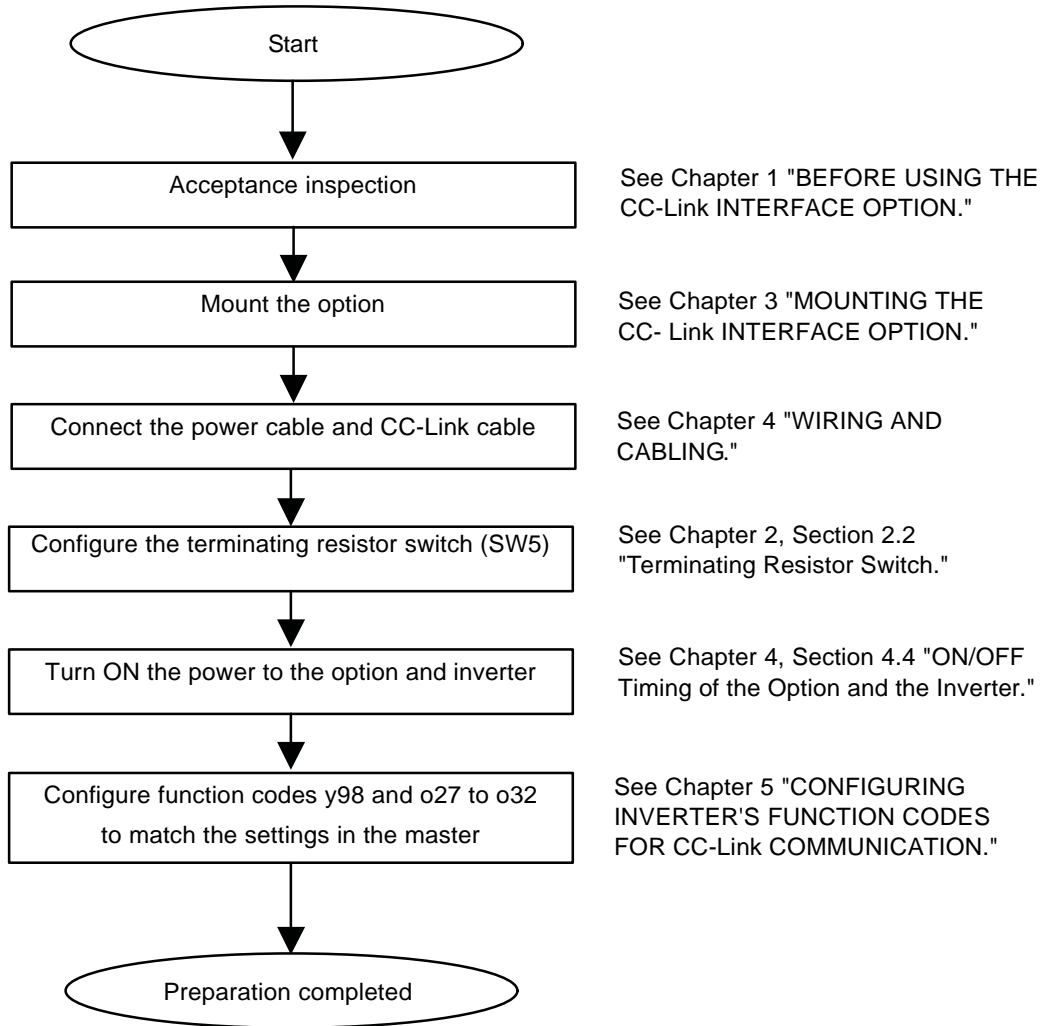

Now the inverter is ready to run via CC-Link.

After confirming that the CC-Link master has been set up, check that the communications link is established according to the ON/OFF states of the LED status indicators (see Chapter 2, Section 2.3 "LED Status Indicators").

After the CC-Link master becomes ready, run the sequencer to operate the inverter via CC-Link.

Chapter 7 LIST OF I/O SIGNALS

7.1 Remote I/O Signals

(1) Remote outputs (Master Inverter)

Device No.	Signal name	Description	Remarks
RY0	Run forward command	OFF: Stop command ON: Run forward command	Simultaneously turning RY0 and RY1 ON results in 0 Hz of frequency.
RY1	Run reverse command	OFF: Stop command ON: Run reverse command	
RY2	Terminal X1 function	Terminal command assigned by inverter's function code E01 *1	Factory default: SS1
RY3	Terminal X2 function	Terminal command assigned by inverter's function code E02 *1	Factory default: SS2
RY4	Terminal X3 function	Terminal command assigned by inverter's function code E03 *1	Factory default: SS4
RY5	Terminal X4 function	Terminal command assigned by inverter's function code E04 *1	Factory default: BX
RY6	Terminal X5 function	Terminal command assigned by inverter's function code E05 *1	Factory default: RST
RY7	Not used.	--	--
RY8	Not used.	--	--
RY9	Secondary side output cut off (BX)	ON: Coast to a stop	Effective only when the run command source is CC-Link.
RYA	Not used.	--	--
RYB	Not used.	--	--
RYC *2	Monitor command	Turning this signal ON causes the inverter to store monitored values into remote registers RWr0, 1, 4 to 7 and then turns the "Monitoring" signal (RXC) ON.	
RYD *3	Frequency command (RAM)	Turning this signal ON writes the reference frequency (RWw1) to the inverter's RAM. Upon completion of writing, the "Frequency setting completed" signal (RXD) is turned ON.	
RYE	Not used.	--	
RYF *4	Command code execution request	Turning this signal ON executes processing corresponding to command codes specified in RWw2, 10, 12, 14, 16, and 18. After execution of those command codes, the "Command code execution completed" signal (RXF) is turned ON. If a command code execution error occurs, the error factor will be set to the response code (RWr2).	
RY1A *5	Alarm reset request flag	Turning this signal ON and then OFF when a trip has occurred resets the trip state and turns this flag (RX1A) OFF.	

RR*1 For details about inverter's function codes E01 to E05, refer to the FRENIC-Multi Instruction Manual (INR-SI47-1204-E), Chapter 5 "FUNCTION CODES." Depending upon terminal commands assigned to terminals X1 through X5, these signals may not be operated via CC-Link. For details, refer to the RS-485 Communication User's Manual (MEH448), Chapter 5, Section 5.1.2 [3] "Operation command data."

*2 While the "Monitor command" (RYC) is ON, the monitored values are constantly updated.

*3 While the "Frequency command" (RYD) is ON, the current reference frequency (RWw1) is constantly reflected on the speed.

*4 Each time the "Command code execution request" (RYF) is turned ON, the command specified by the command code executes once. To execute it again, it is necessary to turn the "Command code execution request" (RYF) ON again.

*5 The "Alarm reset request flag" (RY1A) should be turned ON and then OFF.

(2) Remote inputs (Inverter Master)

Device No.	Signal name	Description	Remarks
RX0	Running forward	OFF: Except running in forward direction (Stopped or Rotating in reverse direction) ON: Rotating in forward direction	--
RX1	Running reverse	OFF: Except running in reverse direction (Stopped or Rotating in forward direction) ON: Rotating in reverse direction	--
RX2	Terminal Y1 function	Terminal status assigned by inverter's function code E20 *1	Factory default: RUN
RX3	Terminal Y2 function	Terminal status assigned by inverter's function code E21 *1	Factory default: OL
RX4	Not used.	--	--
RX5	Not used.	--	--
RX6	Not used.	--	--
RX7	Terminal 30A/B/C function	Terminal command assigned by inverter's function code E27 *1	Factory default: ALML
RXC	Monitoring	This signal is turned ON when turning the "Monitor command" (RYC) ON has caused the inverter to store monitored values into remote registers RWr0, 1, 4 to 7. Turning the "Monitor command" (RYC) OFF turns this signal OFF.	
RXD	Frequency setting completed	This signal is turned ON when turning the "Frequency command" (RYD) ON has written the reference frequency into the inverter. Turning the "Frequency command" (RYD) OFF turns this signal OFF.	
RXE	Not used.	--	
RXF	Command code execution completed	This signal is turned ON when turning the "Command code execution request" (RYF) ON has completed the execution of processing corresponding to command codes (specified in RWw2, 10, 12, 14, 16, and 18). Turning the "Command execution request" (RYF) OFF turns this signal OFF.	
RX1A	Alarm state flag	This signal is turned ON when the inverter has tripped.	
RX1B	Remote station ready	This signal is turned ON when powering on the inverter or resetting the hardware has readied the inverter. (This signal is used for interlocking with reading or writing from/to the master unit.) This signal is turned OFF concurrently when the "Alarm state flag" (RX1A) is turned ON if the inverter trips.	

*1 For details about inverter's function codes E20, E21 and E27, refer to the FRENIC-Multi Instruction Manual (INR-SI47-1204-E), Chapter 5 "FUNCTION CODES."

7.2 Remote Registers

(1) Remote registers RWw (Master Inverter)

Device No.	Signal name	Description	Remarks
RWw0	Monitor code 2/ Monitor code 1	Write the codes (listed in Table 7.1) of monitor items to be referred to, into RWw0. After that, turning the RYC ON stores the value of those monitor items into RWr0 and RWr1.	The lower and upper bytes correspond to monitor codes 1 and 2, respectively.
RWw1	Reference frequency	Write the reference frequency into RWw1. After that, turning the RYD ON sets up that frequency to the inverter. After completion of frequency setting, the RXD is turned ON.	Unit: 0.01 Hz
RWw2	Command code	Write one of command codes (listed in Table 7.2) into RWw2, which are required for execution of the following: writing/reading of operation methods (run command sources) and inverter's function codes, referring to the alarm history, alarm resetting, etc. After writing of a command code, turning the RYF ON executes that command. Upon completion of the execution, the RXF is turned ON.	The command code format for specifying inverter's function codes is shown in Table 7.4.
RWw3	Write data	Write object data specified in RWw2, into RWw3, if necessary. After writing into RWw2 and RWw3, turn the RYF ON. If no write data is required, zero (0) should be written into RWw3.	
RWw4	Monitor code 3	Write the code (listed in Table 7.1) of monitor item to be referred to, into the corresponding register (RWwn). After that, turning the RYC ON stores the data of the monitor item into the RWrn. ("n" denotes any of the corresponding register numbers 4 to 7.)	
RWw5	Monitor code 4		
RWw6	Monitor code 5		
RWw7	Monitor code 6		
RWw8	Alarm history	Write 0000, 0100, 0200, or 0300 into RWw8 to specify which alarm code--latest, last, 2nd last, or 3rd last--should be read out, respectively. (The lower 8 bits are fixed to 00 _H .) The content of the specified alarm code and its related information are stored in RWr8, 9, A, B, and C.	Latest: 0000 Last: 0100 2nd last: 0200 3rd last: 0300
RWw9	PID set value (SV)	Write the PID set value into RWw9. The setting range is from -150.00% to 150.00%.	Unit: 0.01%
RWwA	Not used.	--	
RWwB	Not used.	--	
RWw10	Command code 2	Use these registers in the same way as RWw2. After writing into these registers, turning the RYF ON executes these command codes in the order of RWw2, 10, 12, 14, 16, and 18. Upon completion of execution of RWw18, the RXF is turned ON. To nullify the execution of RWw10 to 18, FFFF _H should be written into these registers.	
RWw12	Command code 3		
RWw14	Command code 4		
RWw16	Command code 5		
RWw18	Command code 6		

Device No.	Signal name	Description	Remarks
RWw11	Write data 2	Write object data specified in RWw10, 12, 14, 16, and 18, if necessary, into RWw11, 13, 15, 17, and 19, respectively. After writing into RWw10, 12, 14, 16, and 18 and their respective registers RWw11, 13, 15, 17, and 19, the RYF should be turned ON. If no write data is required, zero (0) should be written into each of RWw11, 13, 15, 17, and 19.	
RWw13	Write data 3		
RWw15	Write data 4		
RWw17	Write data 5		
RWw19	Write data 6		

CC-Link extension

In CC-Link version 1.10, RWw0 to RWw3 are available.

In CC-Link version 2.00,

with 2X setting, RWw0 to RWw7 are available

with 4X setting, RWw0 to RWwF (RWw9 for this option) are available

with 8X setting, RWw0 to RWw1F (RWw19 for this option) are available.

(2) Remote registers RWr (Inverter Master)

Device No.	Signal name	Description	Remarks
RWr0	Monitored value 1	Turning the RYC ON stores the value of the monitor item specified by "Monitor code 1" (RWw0), into RWr0.	See Table 7.1 for monitor item codes.
RWr1	Monitored value 2	Turning the RYC ON stores the value of the monitor item specified by "Monitor code 2" (RWw0), into RWr1.	
RWr2	Response code	Turning the RYF ON stores the response code for the command code specified in RWw2, into RWr2. If the command code has normally executed, zero (0) is automatically written into RWr2; if any error has occurred during processing of the command code, any value other than zero is written.	See Table 7.3 for response codes.
RWr3	Read data	If the command code has normally executed, the response data for that command (specified by the command code) is automatically written into RWr3.	
RWr4	Monitored value 3	Turning the RYC ON stores the value of the monitor item specified by RWwn, into the corresponding RWrn. ("n" denotes any of the register numbers 4 to 7.)	
RWr5	Monitored value 4		
RWr6	Monitored value 5		
RWr7	Monitored value 6		
RWr8	Alarm code	The content of the alarm code specified in RWw8 is automatically written into the lower 8 bits of RWr8. The upper 8 bits of RWw8 will be echoed back into the upper 8 bits of RWr8.	See Chapter 9 for alarm codes.
RWr9	Output frequency at an alarm occurrence	This register stores the output frequency applied at the occurrence time of the alarm specified in RWw8.	Unit: 0.01 Hz
RWrA	Output current at an alarm occurrence	This register stores the output current applied at the occurrence time of the alarm specified in RWw8.	Unit: 0.01 A
RWrB	Output voltage at an alarm occurrence	This register stores the output voltage applied at the occurrence time of the alarm specified in RWw8.	Unit: 0.1 V
RWrC	Cumulative power-ON time at an alarm occurrence	This register stores the cumulative power-ON time elapsed until the occurrence time of the alarm specified in RWw8.	Unit: 1h
RWr10	Response code 2	Turning the RYF ON stores the response code to the command code specified in RWw10, 12, 14, 16, and 18, into RWr10, 12, 14, 16, and 18, respectively. If the command code has normally executed, zero (0) is automatically written into the corresponding register (RWr10, 12, 14, 16, or 18); if any error has occurred during processing of the command code, any value other than zero is written.	See Table 7.3 for response codes.
RWr12	Response code 3		
RWr14	Response code 4		
RWr16	Response code 5		
RWr18	Response code 6		
RWr11	Read data 2		
RWr13	Read data 3		
RWr15	Read data 4		
RWr17	Read data 5		
RWr19	Read data 6		

CC-Link extension

In CC-Link version 1.10, RWw0 to RWw3 are available.

In CC-Link version 2.00,

with 2X setting, RWw0 to RWw7 are available

with 4X setting, RWw0 to RWwF (RWw9 for this option) are available

with 8X setting, RWw0 to RWw1F (RWw19 for this option) are available.

7.3 List of Monitor Item Codes

Table 7.1 lists the monitor item codes available in RWw0, 4 to 7.

Table 7.1 Monitor Item Codes

Code	Monitor item	Unit	Remarks
00 _H	No monitoring (Fixed to 0)	--	
01 _H	Output frequency	0.01 Hz	
02 _H	Output current	0.01 A	
03 _H	Output voltage	0.1 V	
04 _H	No monitoring (Fixed to 0)	--	
05 _H	Reference frequency	0.01 Hz	
06 _H	Motor speed	1 r/min	
07 _H	Calculated torque	0.1%	
08 _H	DC link bus voltage	0.1 V	In units of 1 V
09 _H to 0C _H	No monitoring (Fixed to 0)	--	
0D _H	Input power	0.01 kW	
0E _H	Motor power consumption	0.01 kW	
0F _H	Input terminal status	--	*1
10 _H	Output terminate status	--	*2
11 _H	Load factor	0.1%	Assuming the motor rated torque as 100%
12 _H to 13 _H	No monitoring (Fixed to 0)	--	
14 _H	Cumulative run time	1 hr	
15 _H to 16 _H	No monitoring (Fixed to 0)	--	
17 _H	Cumulative motor run time	1 hr	
18 _H	Current output from the inverter in RMS (based on the inverter rating)	0.1%	Assuming the inverter rated current as 100%
19 _H	Input watt-hour	1 kWhr	
1A _H to 33 _H	No monitoring (Fixed to 0)	--	
34 _H	PID command	0.1%	
35 _H	PID feedback	0.1%	
36 _H	PID deviation	0.1%	
37 _H	No monitoring (Fixed to 0)	--	

*1 The format of the input terminal status signal is shown below. Individual bits denote the ON/OFF states of input terminals on the actual control circuit terminal board. If terminals X1 through X5 are turned ON or OFF by remote outputs RY2 to 6, the change of the ON/OFF states cannot be reflected on this monitor.

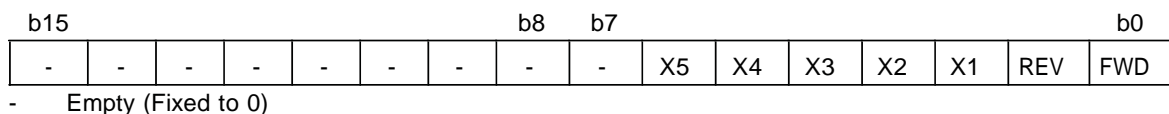

Figure 7.1 Input Terminal Status Signal Format

*2 The format of the output terminal status signal is shown below. Individual bits denote the ON/OFF states of output terminals on the actual control circuit terminal board. Their states are changed in synchronization with remote inputs RX2, 3, and 7.

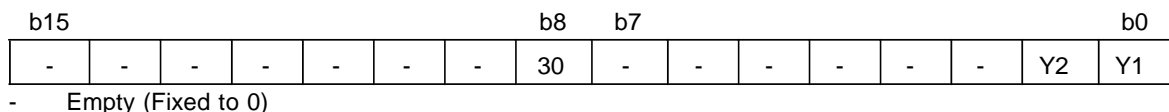

Figure 7.2 Output Terminal Status Signal Format

7.4 Command Codes and Response Codes

Table 7.2 lists the command codes available in remote registers RWw2, 10, 12, 14, and 16. The response codes (to be stored in RWr2, 10, 12, 14, and 16) to those command codes are listed in Table 7.3.

The format of command codes in reading or writing from/to the inverter's function codes is shown in Table 7.4.

Table 7.2 Command Codes

Item	Code number	Description	Remarks
Read from function code	0000 _H to 1163 _H	Reads or writes data from/to inverter's function codes.	Inverter's function codes should be specified in the format shown in Table 7.4.
Write to function code	0080 _H to 11E3 _H		
Read from operation method (run command source)	007B _H	0000 _H : Link operation (CC-Link) 0001 _H : Terminal command for external drive 0002 _H : Keypad operation	
Write to operation method (run command source)	00FB _H	0003 _H : Others 0000 _H : Link operation (CC-Link) 0001 _H : Terminal command for external drive	Change to y98=3 Change to y98=0 and F02=1 Change to y98=0, F02=0, and F01=0
Read from the latest and last alarm codes	0074 _H	0002 _H : Keypad operation Reads the content of the latest and last alarm codes.	Lower byte: Latest alarm code Higher byte: Last alarm code (The contents of alarm codes are detailed in Chapter 9.)
Read from the 2nd and 3rd last alarm codes	0075 _H	Reads the content of the 2nd and 3rd last alarm codes.	Lower byte: 2nd last alarm code Higher byte: 3rd last alarm code (The contents of alarm codes are detailed in Chapter 9.)
Read reference frequency	006D _H		The allowable setting range is from 0 to +/-20000. Specify the ratio of the frequency relative to the maximum frequency (defined by F03 in Hz) being assumed as 20000.
Write reference frequency	00ED _H	Reads out the reference frequency via CC-Link. Writes the reference frequency. (This frequency is effective only when the frequency command source is CC-Link.)	
Clear alarm history	00F4 _H		
Reset alarm	00FD _H	9696 _H : Clears alarm history.	

9696_H: Resets tripped state.

Code number	Item	Description
0000	Normal (No error)	Execution of command code has been normally completed.
0001 _H	Not allowed to write	- Attempted to write to function code whose data cannot be changed while the inverter is running.
0001 _H		- Attempted to write to function code whose data is being edited from the keypad.
	Invalid command code	An invalid command code has been specified.
0002	Out of setting range	Write data is out of the allowable setting range.

Table 7.4 Command Code Format for Specifying Inverter's Function Codes

(bit 15)							(bit 0)									
15	14	13	12	11	10	9	8	7	6	5	4	3	2	1	0	
Empty (Fixed to 0)			Function code group					0: Read 1: Write	Function code number 00 to 99 (00 _H to 63 _H)							
			00H (=0): F codes (F00 to F99)													
			01H (=1): E codes (E00 to E99)													
			02H (=2): C codes (C00 to C99)													
			03H (=3): P codes (P00 to P99)													
			04H (=4): H codes (H00 to H99)													
			06H (=6): o codes (o00 to o99)													
			07H (=7): S codes (S00 to S99)													
			08H (=8): M codes (M00 to M99)													
			0DH (=13): J codes (J00 to J99)													
			0EH (=14): y codes (y00 to y99)													
			0FH (=15): W codes (W00 to W99)													
			10H (=16): X codes (X00 to X99)													
			11H (=17): Z codes (Z00 to Z99)													



Inverter's communication dedicated function codes S01, S05, and S06 are read-only. Attempting to write to those function codes will result in a "Not allowed to write" error (Response code: 0001_H). These function codes are functionally equivalent to certain remote outputs and remote registers.

(Examples)

(1) Reading from H95

Function code group: 04_H, Function code number: 95 (=5F_H), bit 7 = 0 (Read)

Set "045F_H" to the command code

(2) Writing "10" to E20

Function code group: 01_H, Function code number: 20 (=14_H), bit 7 = 1 (Write)

Set "0194_H" to the command code

Write data: 10 (000A_H)

Set "000A_H" to the write data

The data of inverter's function codes should be specified in the individual data formats. For details about the data formats, refer to the RS-485 Communication User's Manual, Chapter 5, Section 5.2, "Data Formats."

Chapter 8 INVERTER REACTION TO CC-Link COMMUNICATIONS ERRORS

If the inverter detects a CC-Link communications error such as broken wires, it trips with an alarm by factory default. The inverter reaction to be taken when it detects an error can be changed with the inverter's function codes o27 and o28 as listed in Table 8.1.

Table 8.1 Inverter Reaction to CC-Link Communications Errors, Specified with Function Codes o27 and o28

o27	o28	Inverter reaction to CC-Link communications error	Remarks
0, 4 to 9	--	Immediately coast to a stop and trip with .	Factory default
1	0.0 s to 60.0 s	After the time specified by o28, coast to a stop and trip with .	
2	0.0 s to 60.0 s	If the communications link is restored within the time specified by o28, ignore the communications error. After the timeout, coast to a stop and trip with .	
3	--	Keep the current operation, ignoring the communications error. (No trip)	
10	--	Immediately decelerate to a stop. Issue after stopping.	The inverter's function code F08 specifies the deceleration time.
11	0.0 s to 60.0 s	After the time specified by o28, decelerate to a stop. Issue after stopping.	Same as above.
12	0.0 s to 60.0 s	If the communications link is restored within the time specified by o28, ignore the communications error. After the timeout, decelerate to a stop and trip with .	Same as above.
13	--	Immediately turn run command OFF. (No trip)	
14	--	Force to rotate the motor in forward direction. (No trip)	
15	--	Force to rotate the motor in reverse direction. (No trip)	

 In any of the following cases, the inverter does not take reactions specified in Table 8.1 when it detects a CC-Link communications error, ignoring the occurrence of the error.

- 1) The CC-Link communications link has not been established once after the option was turned ON.
- 2) Both run command and frequency command sources specified are not CC-Link (that is, any of the following three).
 - Inverter's function code y98 = 0
 - Terminal command **LE** is assigned to a terminal X and the **LE** is OFF.
 - Inverter's function code y99 = 3 or y99 data = y98 data.

Chapter 9 LIST OF INVERTER ALARM CODES

Through CC-Link, the master can monitor the information on alarms (in Table 9.1) that have occurred in the inverter, by using the following procedure.

- (1) Specify which alarm code--latest, last, 2nd last, or 3rd last--should be read out, into the remote register RWw8. (The alarm code will be stored in RWr8.)
- (2) Specify command codes 0074_H and 0075_H (in remote registers RWw2, 10, 12, 14, 16, or 18) to read out alarm codes.
- (3) Use inverter's communication dedicated function codes M16 to M19 to read out the latest, last, 2nd last, and 3rd last alarm codes, respectively.

Table 9.1 List of Inverter Alarm Codes

Alarm code	Description		Alarm code	Description	
0 (00 _H)	No alarm	---	22 (16 _H)	Braking resistor overheated	<i>dbH</i>
1 (01 _H)	Overcurrent (during acceleration)	<i>OL1</i>	23 (17 _H)	Motor 1 overload	<i>OL1</i>
2 (02 _H)	Overcurrent (during deceleration)	<i>OL2</i>	24 (18 _H)	Motor 2 overload	<i>OL2</i>
3 (03 _H)	Overcurrent (During running at constant speed)	<i>OL3</i>	25 (19 _H)	Inverter overload	<i>OLU</i>
5 (05 _H)	Ground fault	<i>EF</i>	31 (1F _H)	Memory error	<i>Er1</i>
6 (06 _H)	Overvoltage (during acceleration)	<i>OU1</i>	32 (20 _H)	Keypad communications error	<i>Er2</i>
7 (07 _H)	Overvoltage (during deceleration)	<i>OU2</i>	33 (21 _H)	CPU error	<i>Er3</i>
8 (08 _H)	Overvoltage (during running at constant speed or being stopped)	<i>OU3</i>	34 (22 _H)	Interface option communications error	<i>Er4</i>
10 (0A _H)	Undervoltage	<i>LU</i>	35 (23 _H)	CC-Link communications error	<i>Er5</i>
11 (0B _H)	Input phase loss	<i>Lin</i>	36 (24 _H)	Operation protection	<i>Er6</i>
14 (0E _H)	Fuse blown	<i>FUS</i>	37 (25 _H)	Tuning error	<i>Er7</i>
16 (10 _H)	Charger circuit fault	<i>PbF</i>	38 (26 _H)	RS-485 communications error	<i>Er8</i>
17 (11 _H)	Heat sink overheat	<i>OH1</i>	46 (2E _H)	Output phase loss	<i>OPL</i>
18 (12 _H)	Alarm issued by an external device	<i>OH2</i>	51 (33 _H)	Data saving error due to undervoltage	<i>ErF</i>
19 (13 _H)	Inverter overheat	<i>OH3</i>	53 (35 _H)	RS-485 communications error (option)	<i>ErP</i>
20 (14 _H)	Motor protection (PTC thermistor)	<i>OH4</i>	54 (36 _H)	LSI error (Power printed circuit board)	<i>ErH</i>

Chapter 10 APPLICATION PROGRAM EXAMPLES

10.1 System Configuration

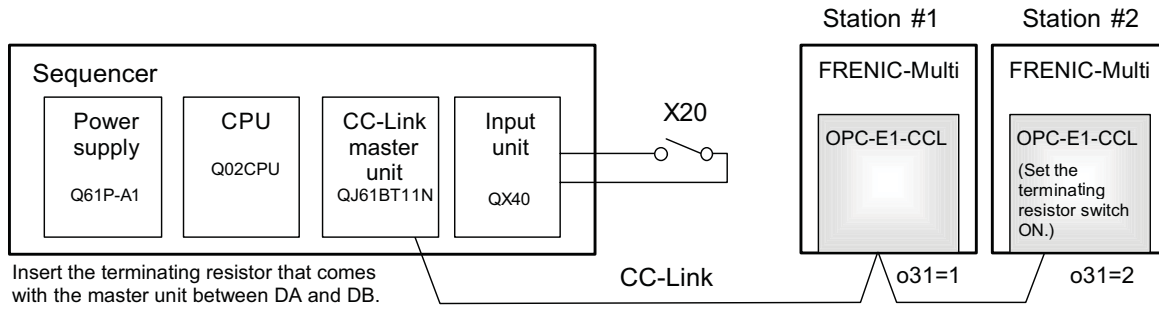

Figure 10.1 System Configuration

10.2 Network Parameter Settings

In program examples given in this chapter, the network parameters of the master unit are set as listed in Table 10.1

Table 10.1 Network Parameter Settings of the Master Unit

Parameter		Settings
Start I/O No.		0000
Operation settings	For units where a data link error is detected	Clear input
	At the time of CPU stop	Refresh
Type		Master unit
Mode		Remote Net Ver. 1 mode
Total number of slaves connected		2
Remote input (RX)		X1000
Remote output (RY)		Y1000
Remote register (RW _r)		W0
Remote register (RW _w)		W100
Special relay (SB)		SB0
Special register (SW)		SW0
Retry count		3
Automatic reconnection station count		1
For CPU down		Stop
Scan mode		Asynchronous

10.3 Relationship between Master Station Device and Remote I/O and Remote Register

(1) Remote I/Os

Figure 10.2 shows the relationship between the master station devices and remote I/Os (RX and RY) in the program examples given on the following pages.

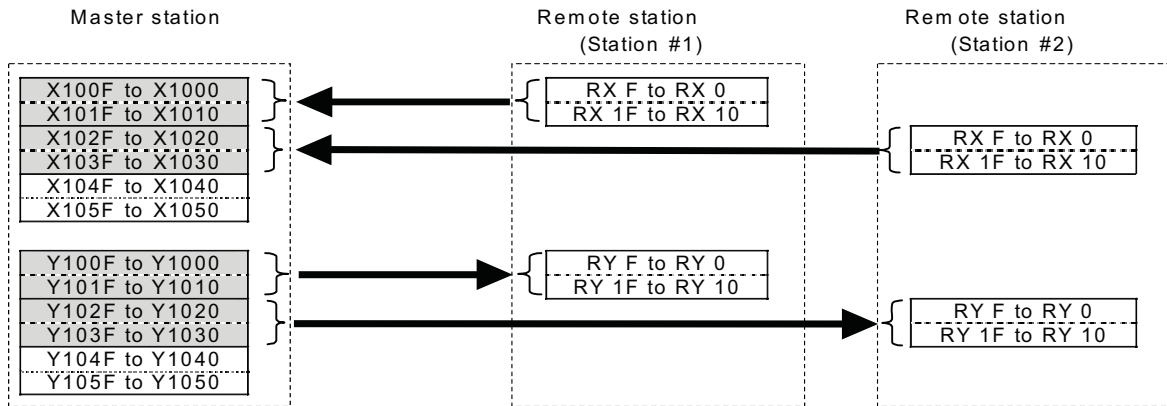

Figure 10.2 Relationship between Master Station Devices and Remote I/Os

(2) Remote registers

Figure 10.3 shows the relationship between the master station devices and remote registers (RWw and RWr) in the program examples given on the following pages.

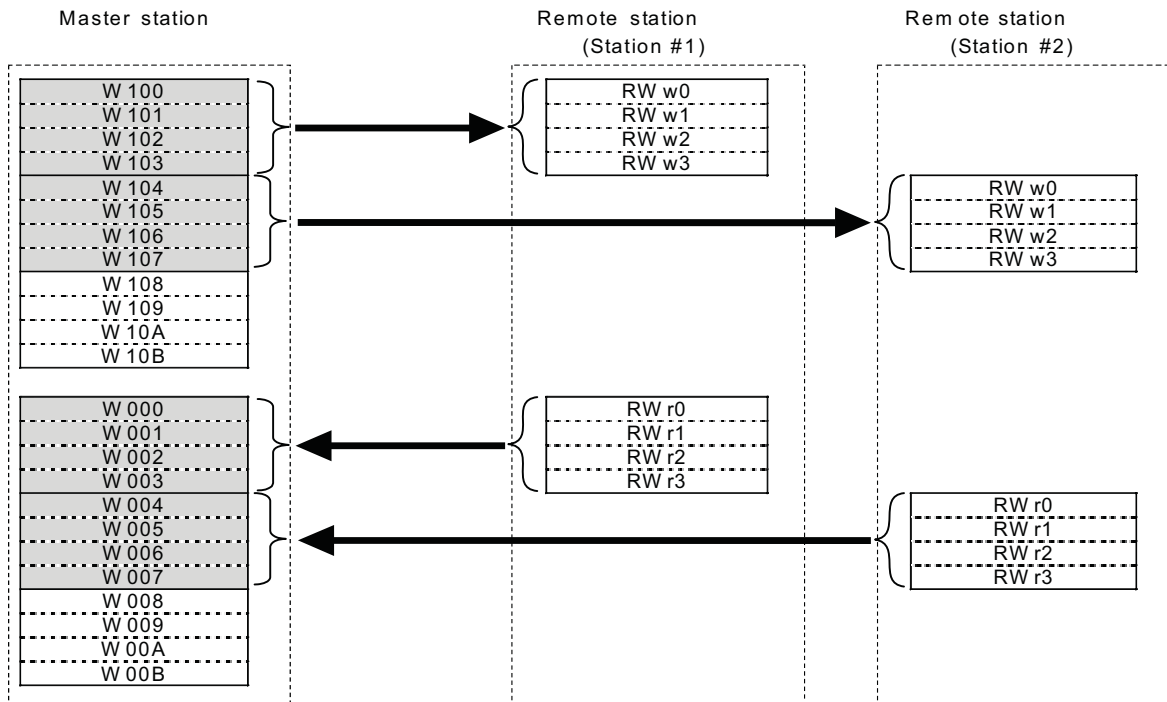

Figure 10.3 Relationship between Master Station Devices and Remote Registers

10.4 CC-Link Startup Program

Shown below is a CC-Link startup program example to run for ACPU.

No startup program is required for QCPU which starts up CC-Link communication with the network parameter settings made in the master unit.

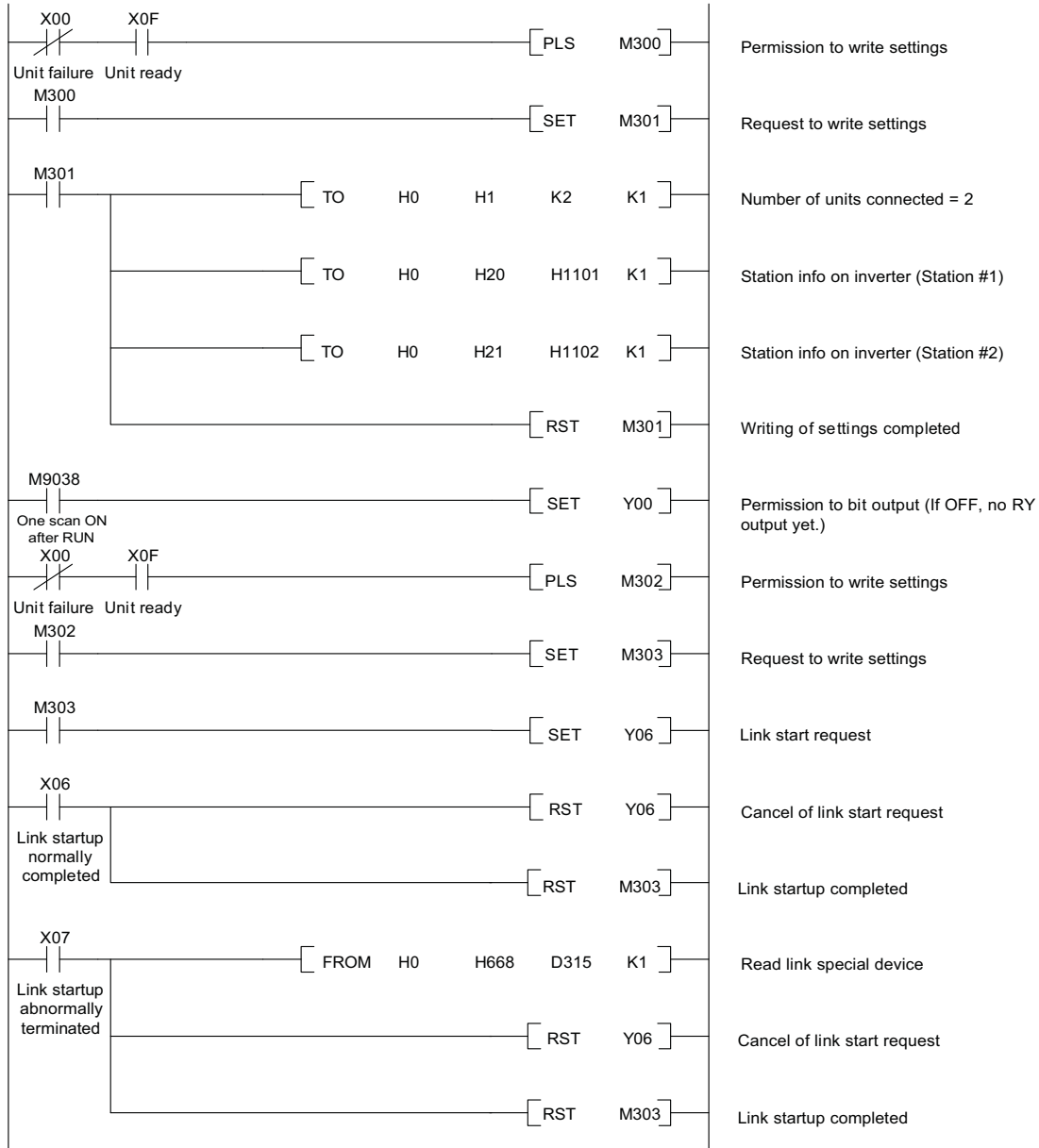

Figure 10.4 CC-Link Startup Program Example (for ACPU only)

10.5 Program Example Using the Inverter Running Status Read

The program example shown below turns ON the auxiliary relay M100 when FRENIC-Multi station #1 starts running.

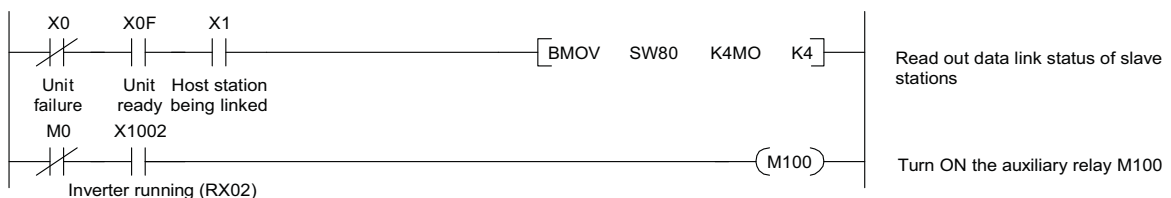

Figure 10.5 Program Example

10.6 Program Example for Changing the Operation Mode

The program example shown below switches the operation mode of FRENIC-Multi station #1 to network operation (specifying CC-Link as both run command and frequency command sources).

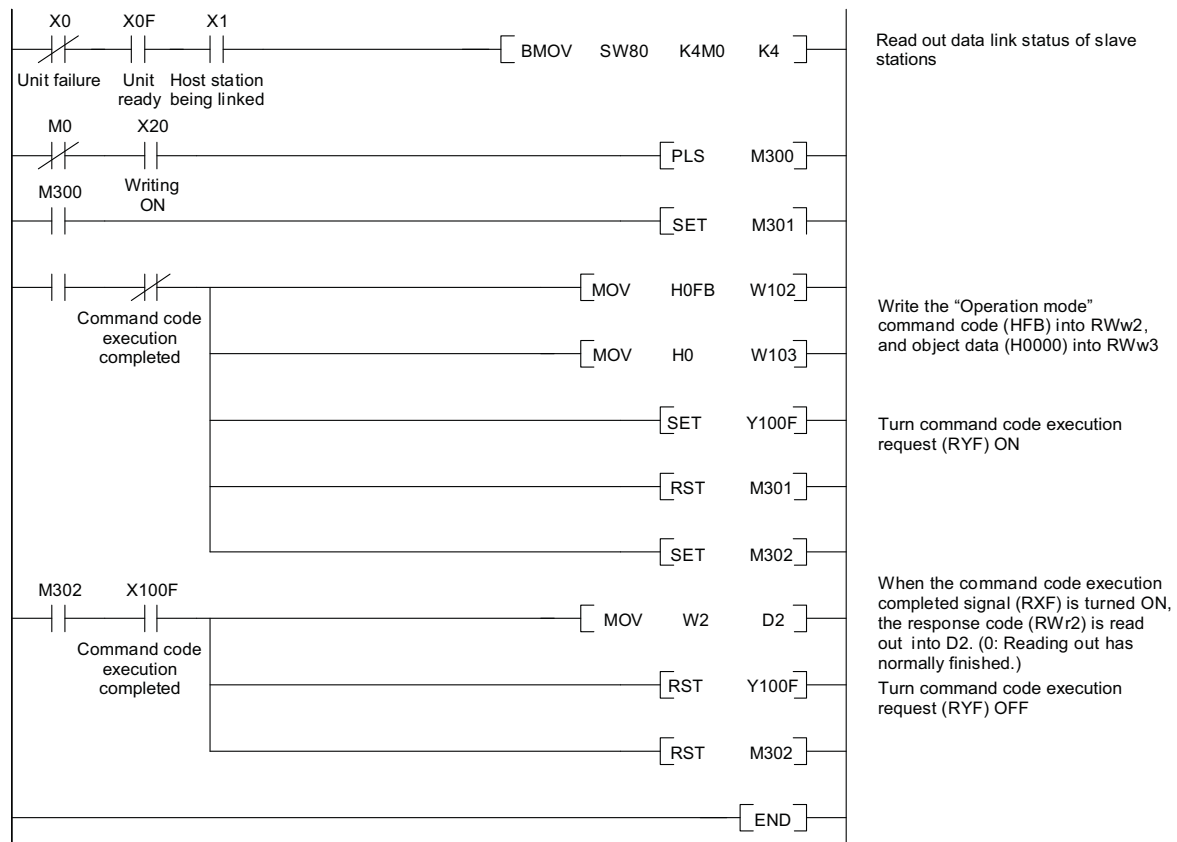

Figure 10.6 Program Example

10.7 Program Example for Specifying Run Command

The program example shown below writes the run forward command (FWD) into FRENIC-Multi station #1

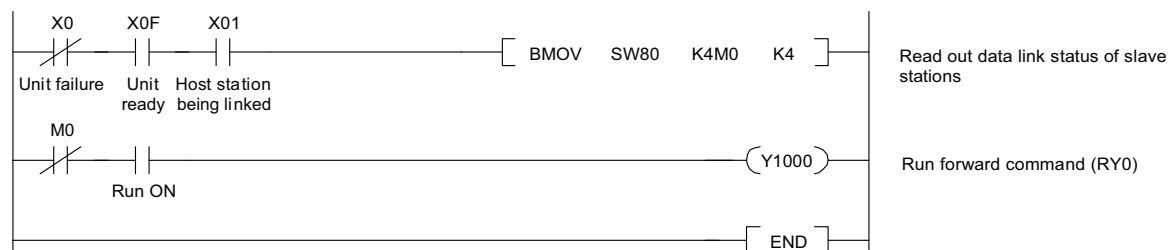

Figure 10.7 Program Example

10.8 Program Example for Monitoring the Output Frequency

The program example shown below reads out the output frequency from FRENIC-Multi station #1 into data register D1.

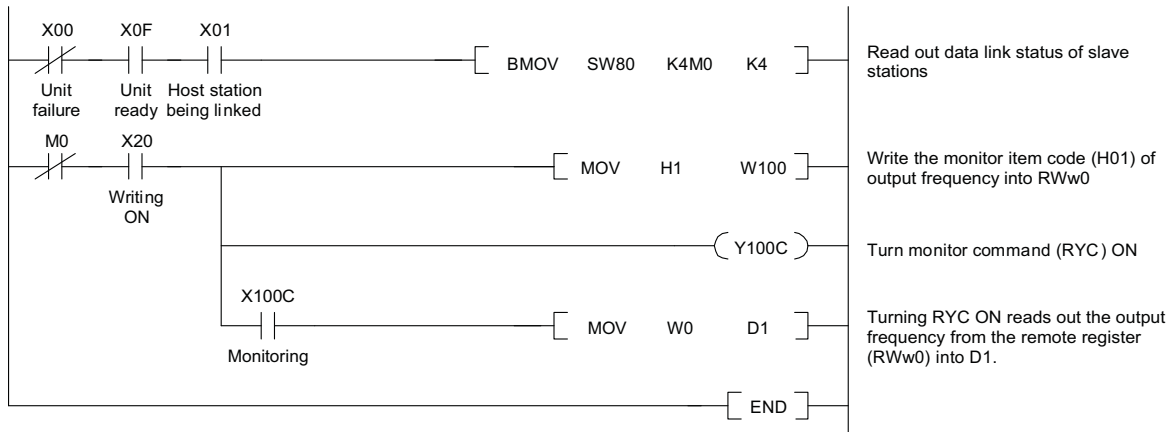

Figure 10.8 Program Example

10.9 Program Example for Reading from the Inverter's Function Code Data

The program example shown below reads out the F07 data (Acceleration time 1) from FRENIC-Multi station #1

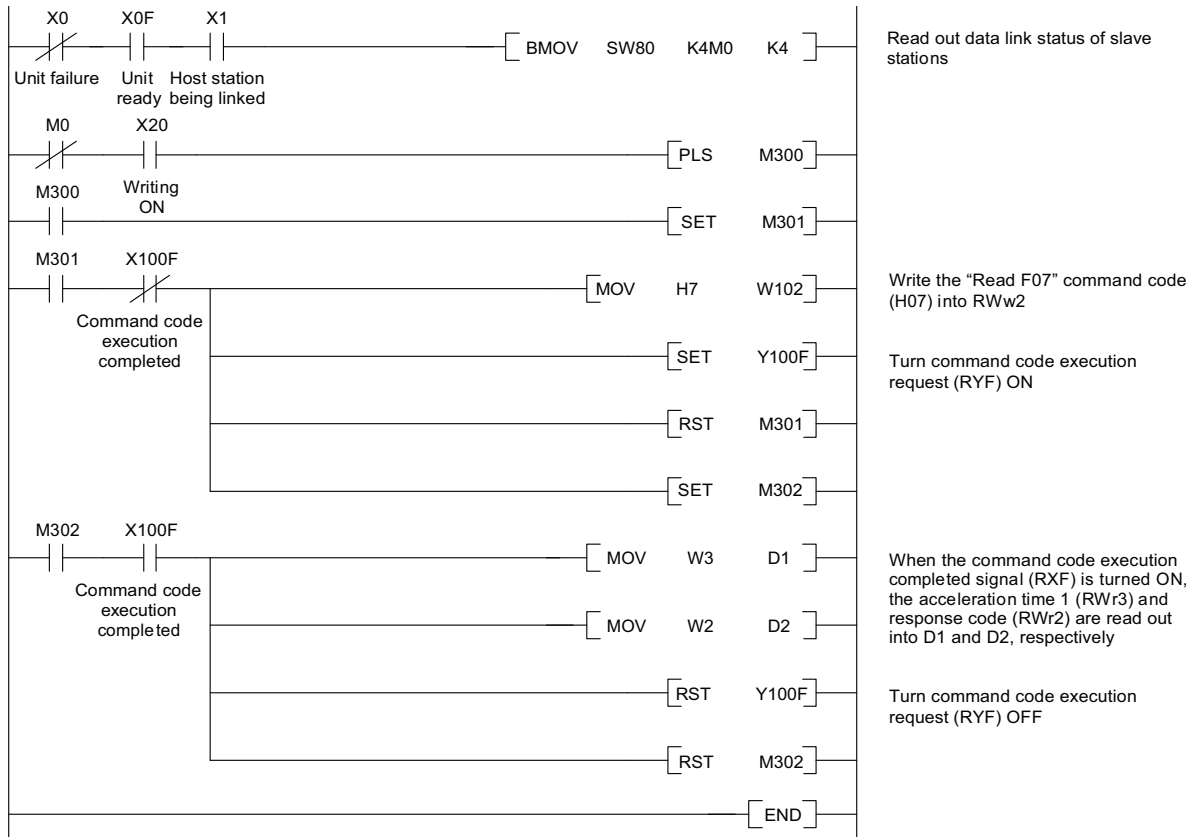

Figure 10.9 Program Example

10.10 Program Example for Writing to Inverter's Function Code Data

The program example shown below writes 3.0 s to the F07 data (Acceleration time 1) of FRENIC-Multi station #1.

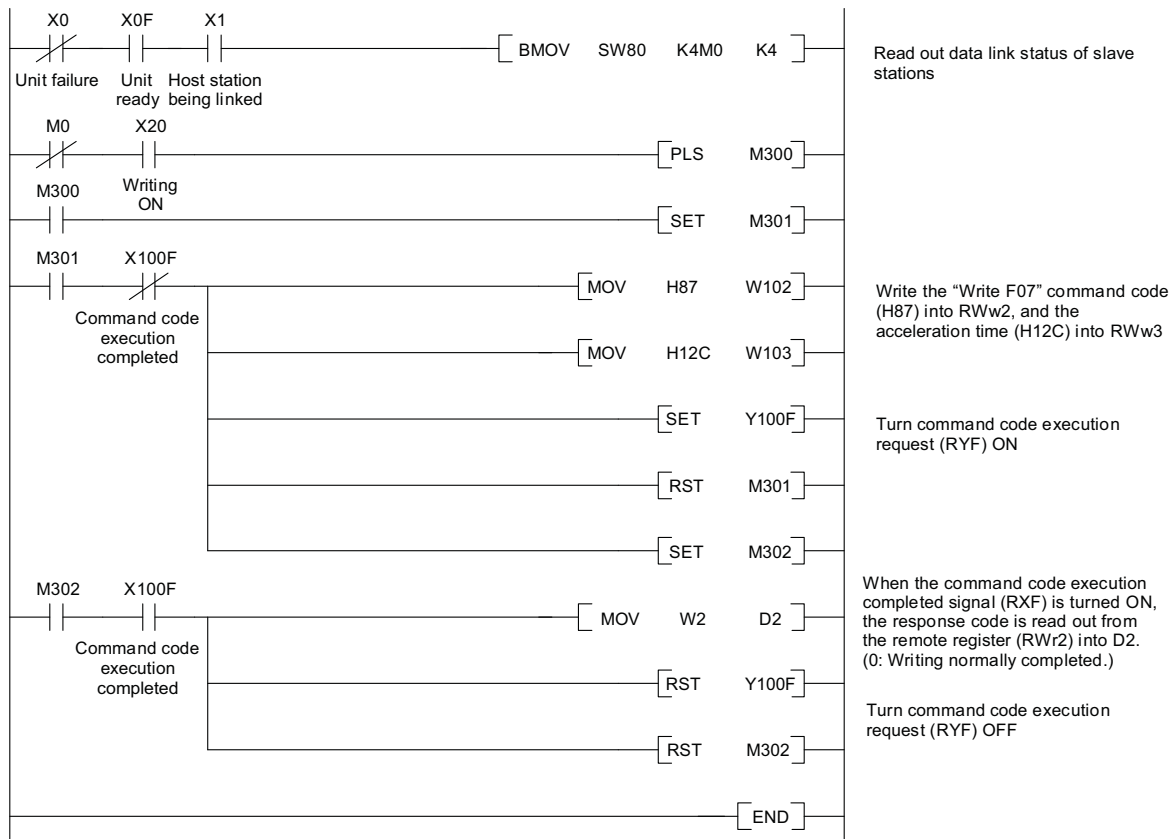

Figure 10.10 Program Example

10.11 Program Example for Setting up the Reference Frequency

The program example shown below writes the reference frequency 50.00 Hz to FRENIC-Multi station #1.

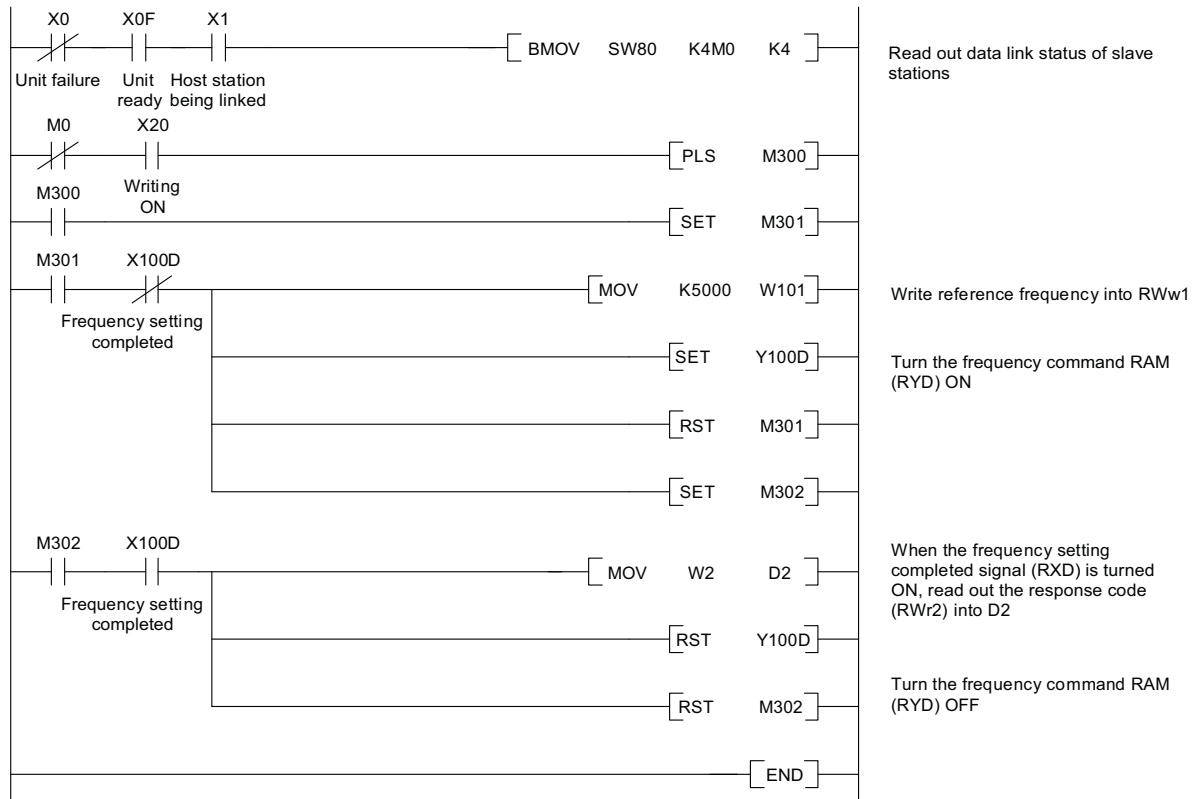

Figure 10.11 Program Example

10.12 Program Example for Reading out Alarm Codes

The program example shown below reads out alarm codes stored in FRENIC-Multi station #1 into data register D1.

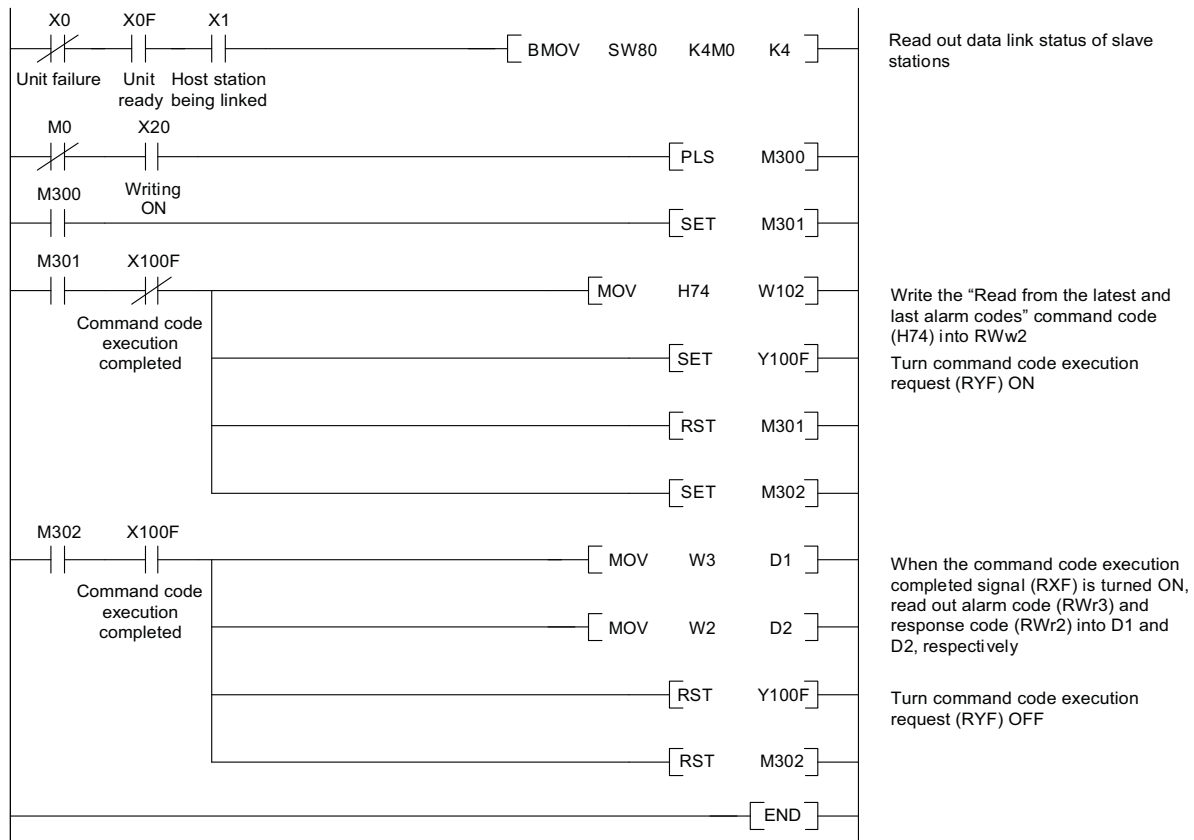

Figure 10.12 Program Example

10.13 Program Example for Resetting a Inverter Trip

The program example shown below resets a trip that has occurred in FRENIC-Multi station #1.

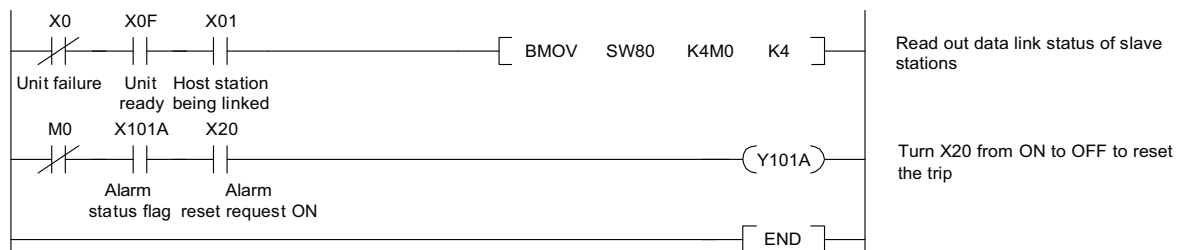
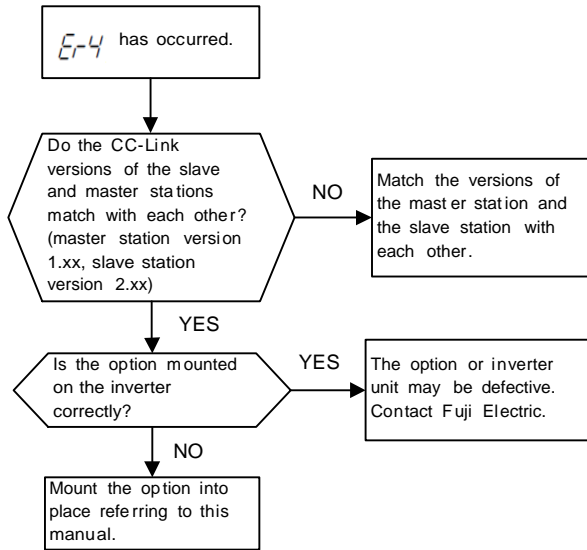

Figure 10.13 Program Example

Chapter 11 TROUBLESHOOTING

(1) Option error (E-4)



(3) Commands via CC-Link not reflected

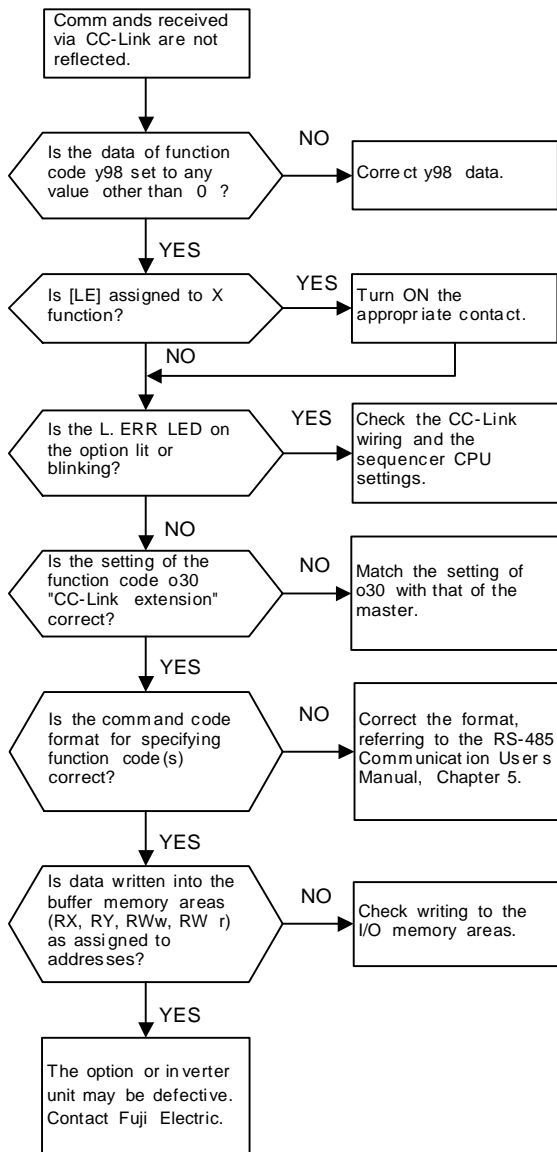

(2) Network error (E-5)

If a network error (CC-Link error) occurs, analyze the cause of the error referring to the RAS information in the sequencer CPU. For the access to the RAS information and its contents, see the Sequencer User's Manual.

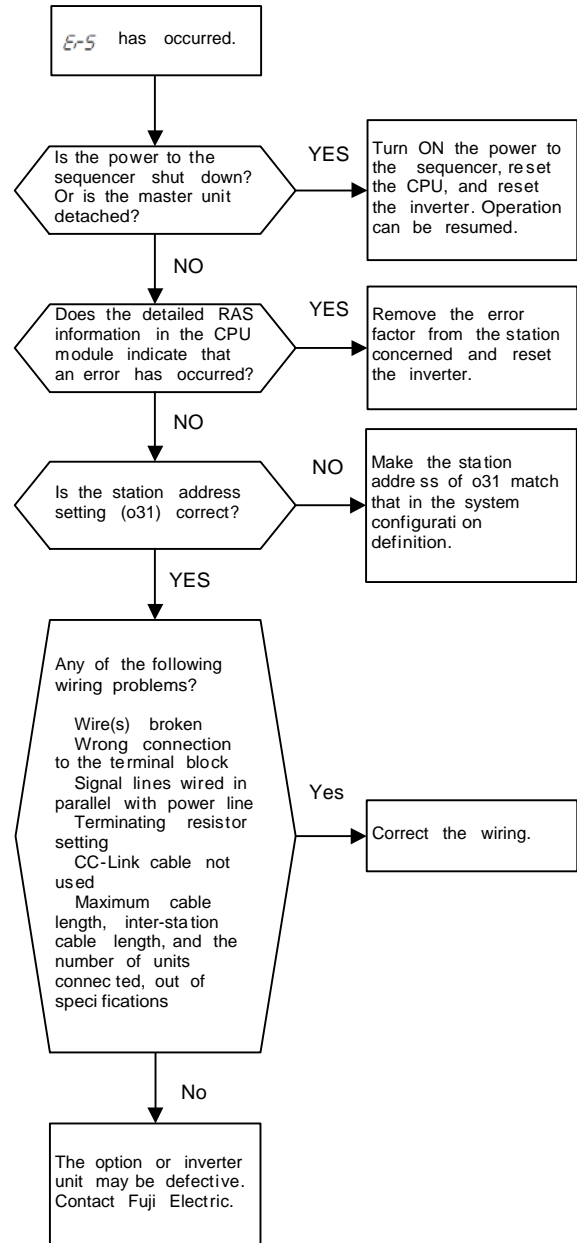

Chapter 12 SPECIFICATIONS

12.1 General Specifications

For items not contained in the following table, the specifications of the inverter apply.

Item	Specifications
Input power voltage	21.6 to 27.0 V
Power consumption	Max. 150 mA, 24 VDC
Operating ambient temperature	-10 to +50 C(14 to + 122 F)
Operating ambient humidity	5 to 95% RH (There shall be no condensation.)
External dimensions	79.6 x 127 x 47.5 mm(3.13 x 5 x 1.87 in)

12.2 CC-Link Specifications

For the items not contained in the following table, the CC-Link specifications apply.

	Specifications
Name	CC-Link interface option
Station type	Remote device station
Number of units connectable	Max. 42 units (one station occupied/unit), compatible with other options
Number of stations occupied	1
CC-Link version	The option complies with CC-Link versions 1.10 and 2.00. It can be configured with the function code o30 as follows: 1 station occupied (CC-Link version 1.10): o30 = 0 or 1 1 station occupied with 2X setting (CC-Link version 2.00): o30 = 2 1 station occupied with 4X setting (CC-Link version 2.00): o30 = 3 1 station occupied with 8X setting (CC-Link version 2.00): o30 = 4 Setting invalid: o30 = Other than the above data
Terminal block for connection	5-pin terminal block (M3x5 screws)
Communications cable	CC-Link dedicated cable -Use the CC-Link dedicated cable in CC-Link system. -Using a cable other than a CC-Link dedicated cable does not assure the CC-Link system performance. -For further information about the CC-Link dedicated cable specifications and inquiries, visit the CC-Link Partner Association's website at: http://www.cc-link.org/eng/t_html/top.html
Station address	1 to 64. The station address can be specified with the inverter's function code o31.
Transmission speed (Baud rate)	10 Mbps (o32 = 4), 5 Mbps (o32 = 3), 2.5 Mbps (o32 = 2), 625 kbps (o32 = 1), 156 kbps (o32 = 0) The transmission speed can be specified with the inverter's function code o32.
LED status indicators	L.RUN: Lights when the option is normally receiving refresh data. It goes off if data transmission is interrupted for a certain period of time. L.ERR: Lights when a communications error has occurred . It blinks if the station address (o31) or the transmission speed (o32) is changed when the power is on. RUN: Lights during normal communication . It blinks when mismatch in CC-Link version settings is found or the connection between the inverter and the option is cut. SD: Lights during data transmission. RD: Lights during data reception.

CC-Link Interface Option "OPC-E1-CCL"

Instruction Manual

First Edition, December 2006

Fuji Electric FA Components & Systems Co., Ltd.

The purpose of this manual is to provide accurate information in the handling, setting up and operating of CC-Link Interface Option "OPC-E1-CCL" for the FRENIC-Multi series of inverters. Please feel free to send your comments regarding any errors or omissions you may have found, or any suggestions you may have for generally improving the manual.

In no event will Fuji Electric FA Components & Systems Co., Ltd. be liable for any direct or indirect damages resulting from the application of the information in this manual.

MEMO

Fuji Electric Systems Co., Ltd.
Fuji Electric Corp. of America

47520 Westinghouse Drive Fremont, CA 94539, U.S.A.
Tel.+1-510-440-1060 Fax.+1-510-440-1063
Toll-free support 1-888-900-FUJI(3854)
INR-SI47-1175-EU Rev 052010

<http://www.fujielectric.com/fecoa/>

Information subject to change without notice.
