



FRENIC-Mini
Remote Keypad "TP-E1"

 **CAUTION**

Thank you for purchasing our Remote Keypad TP-E1.

- This product is designed to remotely control the FRENIC-Mini series of inverters. Read through this instruction manual and be familiar with the handling procedure for correct use.
- Improper handling blocks correct operation or causes a short life or failure.
- Deliver this manual to the end user of the product. Keep this manual in a safe place until the Remote Keypad is discarded.
- For the usage of inverters and optional equipment, refer to the instruction manuals prepared for the FRENIC-Mini series of inverters and its optional equipment.

Copyright © 2003 Fuji Electric FA Components & Systems Co., Ltd.

All rights reserved.

No part of this publication may be reproduced or copied without prior written permission from Fuji Electric FA Components & Systems Co., Ltd.

All products and company names mentioned in this manual are trademarks or registered trademarks of their respective holders.

The information contained herein is subject to change without prior notice for improvement.

Preface

Thank you for purchasing our Remote Keypad "TP-E1."

The Remote Keypad allows you to remotely operate FRENIC-Mini series of inverters. Using this remote keypad, you can perform the operations that are available on the built-in keypad on FRENIC-Mini inverter, such as running and stopping the motor, monitoring the running status, and setting the function codes.

In addition, you can perform "data copying": You can read function code data from an inverter, copy (write) it into another inverter, or verify it.

To use the Remote Keypad, make sure that the FRENIC-Mini inverter is equipped with the RS485 Communications Card (OPC-C1-RS), and connect the two using an optional Remote Operation Extension Cable (CB-5S, CB-3S, or CB-1S, depending on the distance).

This manual describes how to install the Remote Keypad and the "data copying." For other operations that are common to the built-in keypad, refer to the FRENIC-Mini Instruction Manual (INR-SI47-0791-E), Chapter 3.

Before installing and using the Remote Keypad, read through this manual in conjunction with the FRENIC-Mini User's Manual and make yourself familiar with its proper use. Improper use may prevent normal operation or cause a failure or reduced life of the inverter.

Related Publications

Listed below are other publications on the FRENIC-Mini to be consulted in conjunction with this manual as necessary.



- FRENIC-Mini User's Manual (MEH446)
- RS485 Communications User's Manual (MEH448)
- Catalog (MEH441/MEH451)
- Application Guide (MEH449)
- FRENIC-Mini Instruction Manual (INR-SI47-0791-E)
- RS485 Communications Card Installation Manual (INR-SI47-0773)
- Rail Mounting Base Installation Manual (INR-SI47-0774)
- Mounting Adapter Installation Manual (INR-SI47-0775)
- Built-in Braking Resistor Installation Manual (INR-SI47-0838)

Note that these publications are subject to change without notice. Make sure that you have the most up-to-date versions at all times.

■ Safety precautions

Before proceeding with installation, connecting, cabling, wiring, operation, inspection or maintenance, read this manual thoroughly. Make sure also that you have sound knowledge of the product, and familiarize yourself with all safety information and precautions.

Safety precautions are classified into the following two categories in this manual.

 WARNING	Failure to heed the information indicated by this symbol may lead to dangerous conditions, possibly resulting in death or serious bodily injuries.
 CAUTION	Failure to heed the information indicated by this symbol may lead to dangerous conditions, possibly resulting in minor or light bodily injuries and/or substantial property damage.

Failure to heed the information contained under the CAUTION title can also result in serious consequences. These safety precautions are of utmost importance and must be observed at all times.

WARNING

- Be sure to install the terminal block cover before turning the power on. Do not remove the cover during power application.

Otherwise electric shock could occur.



- Do not operate switches with wet hands.

Doing so could cause electric shock.

- If the retry function has been enabled, the inverter may automatically restart after tripping, depending on its cause, causing the motor driven by it to start rotating. In designing a system or a facility using the motor driven by the FRENIC-Mini, make sure that such automatic restart would not cause any personal injury, damage to equipment, or other unintended incidents.

- If the stall prevention function has been selected, the inverter may operate at an acceleration/deceleration time or frequency different from the set ones. Design the machine so that safety is ensured even in such cases.

Otherwise an accident could occur.

- The  key is only effective when function setting (Function code F02) has been established to enable the  key. Prepare an emergency stop switch separately. If you disable the STOP key priority function and enable command (FWD) or (REV), you cannot stop the inverter output by the  key on the built-in keypad.

- If an alarm reset is made with the operation signal turned on, a sudden start will occur. Check that the operation signal is turned off in advance.

Otherwise an accident could occur.

- If you have selected "Active" as the mode of Restart after momentary power failure (F14 = 4 or 5), the inverter will automatically restart, causing the motor driven by it to start rotating. In designing a system or a facility using the motor driven by the FRENIC-Mini, make sure that safety is secured even in such instances.

- If you set the function codes wrongly or without completely understanding the instruction manuals and the FRENIC-Mini User's Manual, the motor may rotate with a torque or at a speed not permitted for the machine.

An accident or injuries could occur.

- Do not touch the inverter terminals while the power is applied to the inverter even if the inverter stops.

Doing so could cause electric shock.

Installation and cabling/wiring of option cards

WARNING

- Do not operate the switch SW1 with wet hands.
Doing so could cause electric shock.
- Before starting installing the RS485 Communications Card, first turn off the power, wait more than 5 minutes, and make sure, using a circuit tester or another appropriate instrument, that the DC voltage between the P (+) and N (-) terminals of the main circuit is less than +25 VDC.
Otherwise electric shock could occur.
- A high voltage is present just on the RS485 Communications Card. Do not remove the cover for the control circuit terminal block (TB) while power is applied.
Doing so could cause electric shock.
- Generally, the sheath of control circuit wires is not reinforced by any insulation. If the control circuit wires come into direct contact with the live main circuit terminal, therefore, the sheath may break. Accordingly, there is a possibility that high voltage on the main circuit may be applied to the control circuit wires. It is DANGEROUS. Be sure to keep the control wires away from the live main circuit terminals.
An accident or electric shock could occur.

Disposal

CAUTION

- Handle this Remote Keypad or the RS485 Communications Card as an industrial waste when disposing of it.
Otherwise injuries could occur.

Others

WARNING

- Never attempt to modify the inverter.
Doing so could cause electric shock or injuries.

GENERAL PRECAUTIONS

Drawings in this manual may be illustrated without covers or safety shields for explanation of detail parts. Restore the covers and shields in the original state and observe the description in the manual before starting operation.

How this manual is organized

This manual is made up of chapters 1 through 4.

Chapter 1. BEFORE USING THE REMOTE KEYPAD "TP-E1"

This chapter describes the points to check upon delivery and lists the inverters the Remote Keypad is designed to interface with.

Chapter 2. INSTALLATION, CABLING, AND WIRING

This chapter describes how to install the Remote Keypad and the RS485 Communications Card and how to connect them with each other.

Chapter 3. OPERATION USING THE REMOTE KEYPAD "TP-E1"

This chapter describes the functions of the Remote Keypad including data copying, as well as how to operate the Remote Keypad.

Chapter 4. SPECIFICATIONS

This chapter lists the general specifications such as operating environments, communication specifications and transmission specifications.

Icons

This manual uses the following icons:



Indicates information that should be observed to make full use of the features and functions provided by this product and the neglect of which may result in an accident.



Refers you to related or more detailed information.

CONTENTS

Preface	i
■ Safety precautions	i
How this manual is organized	iv
Chapter 1 BEFORE USING THE REMOTE KEYPAD "TP-E1"	1-1
1.1 Check Points	1-1
1.2 Inverters with which the Remote Keypad Interfaces	1-1
Chapter 2 INSTALLATION, CABLING, AND WIRING	2-1
2.1 Accessories and Parts Required for Connection	2-1
2.2 Installing the Remote Keypad	2-2
Chapter 3 OPERATION USING THE REMOTE KEYPAD "TP-E1"	3-1
3.1 Familiarizing Yourself with the Remote Keypad	3-1
3.2 Operating the Remote Keypad	3-2
3.3 Data Copying	3-3
Chapter 4 SPECIFICATIONS	4-1
4.1 General Specifications	4-1
4.2 Communication Specifications	4-2
4.3 Transmission Specifications	4-2

Chapter 1 BEFORE USING THE REMOTE KEYPAD "TP-E1"

1.1 Check Points

Unpack the package and check the following:

- (1) The package contains the Remote Keypad and its instruction manual (this book).
- (2) There have been no problems during transportation. In particular, no parts are damaged or have fallen out of place nor are there any dents on the body.
- (3) The model name "TP-E1" is inscribed on the back of the Remote Keypad as shown in Figure 1.1.

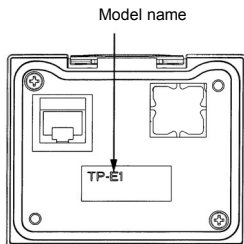

Figure 1.1 Back of Remote Keypad TP-E1

If you find any anomalies, contact your dealer or nearest Fuji Electric sales office.

1.2 Inverters with which the Remote Keypad Interfaces

The Remote Keypad TP-E1 interfaces with the following Fuji inverters:

Series	Type of inverter*	Remarks
FRENIC-Mini	FRN□□□C1S-□□□□ FRN□□□C1E-□□□□ (Each □ has its meaning as shown below, represented by an alphanumeric character.)	The Remote Keypad is fully supported by inverters with a ROM version of C1S10500 or above. (You can check the inverter's ROM version by entering 5_14 in "Maintenance Information" (Menu #5) in Program Mode.) There are restrictions on the support for the Remote Keypad TP-E1 by inverters with a ROM version of C1S10499 or below. For details, contact your Fuji Electric sales office.

* Type of inverter

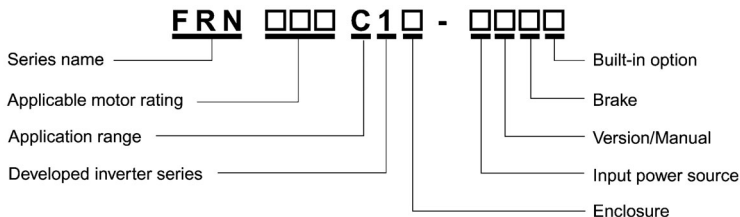

 For the details of the Inverter type ID, refer to the FRENIC-Mini Instruction Manual (INR-SI47-0791-E), Chapter 1, Section 1.1 "Acceptance Inspection."

Chapter 2 INSTALLATION, CABLING, AND WIRING

To connect the Remote Keypad to the FRENIC-Mini inverter, first install the RS485 Communications Card (OPC-C1-RS) on the inverter, and then use an optional Remote Operation Extension Cable (CB-5S, CB-3S, or CB-1S, depending on the distance) or an off-the-shelf LAN cable to interconnect them.

2.1 Accessories and Parts Required for Connection

To connect your Remote Keypad TP-E1 to an inverter, you need the following devices and parts:

Accessories/Parts	Type or Specifications	Remarks
Remote Operation Extension Cable (Note 1)	CB-5S, CB-3S, or CB-1S	You have a choice of three lengths: 5 m, 3 m, and 1 m.
RS485 Communications Card	OPC-C1-RS	Install this into the inverter.
Screws (for mounting the Remote Keypad) (Note 2)	M3 x 12	Get 2 screws beforehand.

Note 1: Alternatively, you can use an off-the-shelf 10BASE-T/100BASE-TX LAN cable (straight type) that meets the ANSI/TIA/EIA-568A Category 5 standard (maximum length: 20 m).

Recommended LAN Cable (for 1 m):

Manufacturer: Sanwa Supply, Co. Ltd.

Model: KB-10T5-01K

KB-STP-01K (shielded cable, EMC-compliant)

Note 2: Use the screws whose lengths are proper to thickness of the mounting enclosure.

2.2 Installing the Remote Keypad

To mount the Remote Keypad on an enclosure, follow the steps below.

Installation Procedures

Follow the steps below after completing the cabling work for the inverter. First, power off the inverter.

- To install the Remote Keypad on an enclosure (see Figure 2.1):
 - ① Cut two square holes on the enclosure as shown in Figure 2.3.
 - ② Mount the Remote Keypad onto the enclosure.
 - ③ Install the RS485 Communications Card on the inverter.
 - ④ Insert the connector on one end of the Remote Operation Extension Cable or LAN cable into the RJ-45 modular jack on the Remote Keypad.
 - ⑤ Insert the connector on the other end of the cable into the RJ-45 modular jack on the RS485 Communications Card mounted on the FRENIC-Mini.
- To use the Remote Keypad in hand (see Figure 2.2):

Follow steps ③ to ⑤ above.

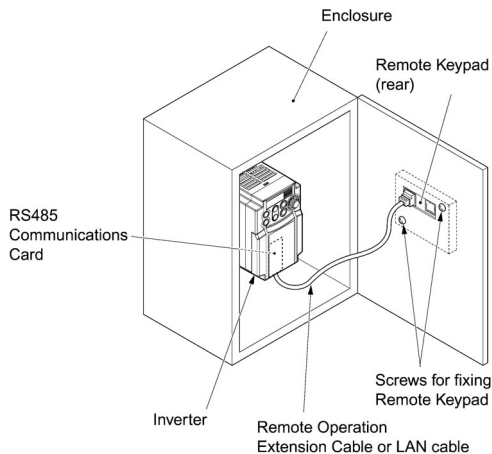

Figure 2.1 To Install the Remote Keypad on an Enclosure

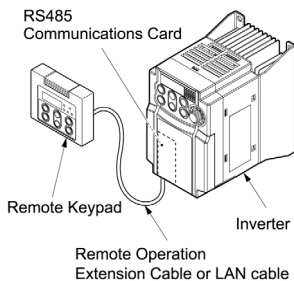

Figure 2.2 To Use the Remote Keypad in Hand

■ To install the Remote Keypad on an Enclosure

- ① Cut a square hole and two screw holes in the enclosure as shown in Figure 2.3.

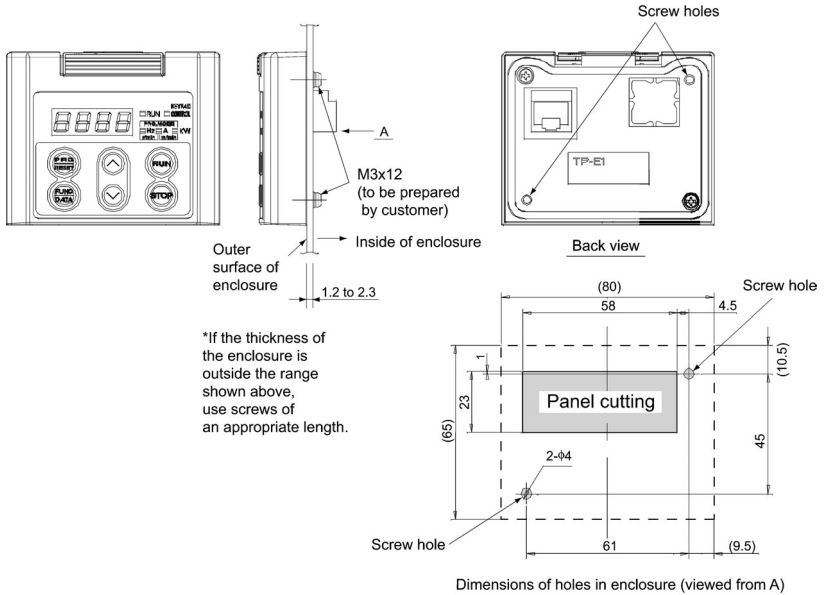

Figure 2.3 Dimensions of Square Hole and Screw Holes

- ② Mount the Remote Keypad TP-E1 onto the enclosure with 2 screws as shown in Figures 2.3 and 2.4.
(Recommended tightening torque: 0.7 N•m)

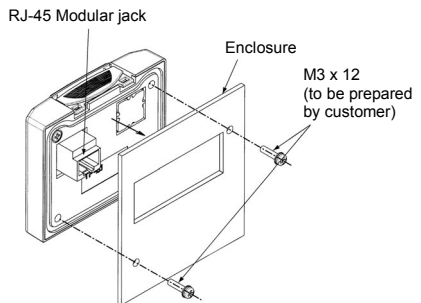

Figure 2.4 Mounting Remote Keypad TP-E1

③ Installing the RS485 Communications Card

WARNING

- Do not operate the switch SW1 with wet hands.
Doing so could cause electric shock.
- Before starting installing the RS485 Communications Card, first turn off the power, wait more than 5 minutes, and make sure, using a circuit tester or another appropriate instrument, that the DC voltage between the P (+) and N (-) terminals of the main circuit is less than +25 VDC.
Otherwise electric shock could occur.
- A high voltage is present just on the RS485 Communications Card. Do not remove the cover for the control circuit terminal block (TB) while power is applied.
Doing so could cause electric shock.
- Generally, the sheath of control circuit wires is not reinforced by any insulation. If the control circuit wires come into direct contact with the live main circuit terminal, therefore, the sheath may break. Accordingly, there is a possibility that high voltage on the main circuit may be applied to the control circuit wires. It is DANGEROUS. Be sure to keep the control wires away from the live main circuit terminals.
An accident or electric shock could occur.

Note Be sure to turn SW1 (termination resistor on/off switch) on the RS485 Communications Card to the OFF position as shown at right. (Upon shipment from the factory, SW1 is set to OFF.)

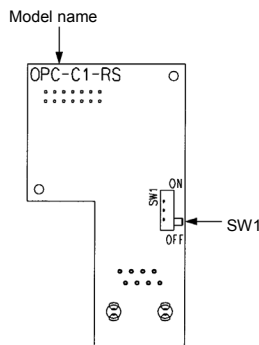

Figure 2.5 Setting of SW1 on RS485 Communications Card

Install the RS485 Communications Card following the steps below.

- 1) If the control circuit terminal block (TB) cover is in place, remove it by inserting your finger in the cutout (near "PULL") in the bottom of it and then pulling it towards you.

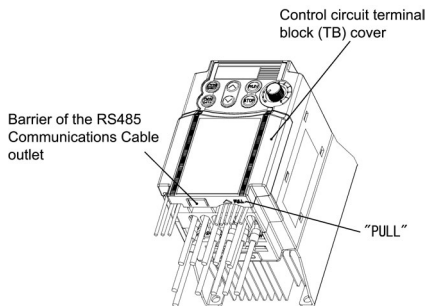

Figure 2.6 Removing the Control Circuit Terminal Block Cover

- 2) Align the RS485 Communications Card with the latch and mount it onto the FRENIC-Mini so that the connector CN1 on the Card is properly inserted.

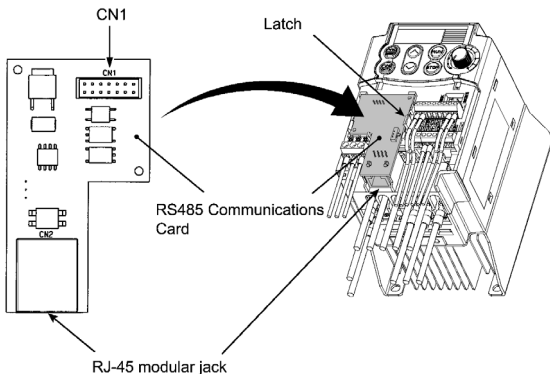

Figure 2.7 Installing the RS485 Communications Card

- 3) Before putting the control circuit TB cover, snip off the barrier of the RS485 Communications Cable outlet with nippers (Figure 2.6).
- 4) Fit the latches provided on the upper end of the control circuit TB cover into the openings in the front face of the FRENIC-Mini, and then close the TB cover. Take care not to pinch control signal wires/cables between the TB cover and the body of the FRENIC-Mini.
- ④ Insert the connector on one end of the Remote Operation Extension Cable or LAN cable into the RJ-45 modular jack on the Remote Keypad TP-E1 (see Figure 2.8).
- ⑤ Insert the connector on the other end of the cable into the RJ-45 modular jack on the RS485 Communications Card mounted on the FRENIC-Mini.

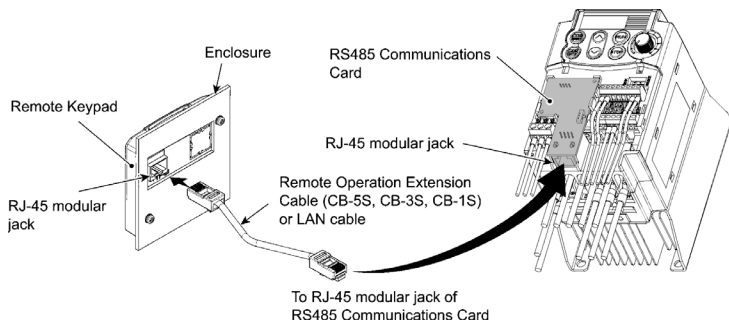

Figure 2.8 Connecting Remote Keypad to the RS485 Communications Card with Remote Operation Extension Cable or LAN Cable

■ To use the Remote Keypad in hand

Follow steps ③ to ⑤ above.

To comply with EMC Directives

Use an EMC filter built-in inverter.

All the connecting cables and wires must be shielded. As shown in Figure 2.9, remove outer sheath of the cable to bare the shield layer for clamping. Ground the shield onto the EMC flange for EMC compliance using clamps provided.

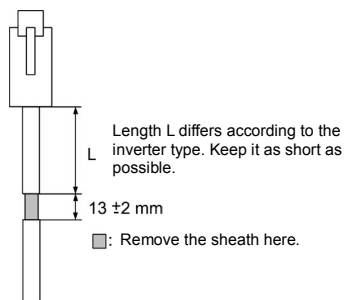

Figure 2.9 Shielded Wire Connection to Comply with EMC Directives

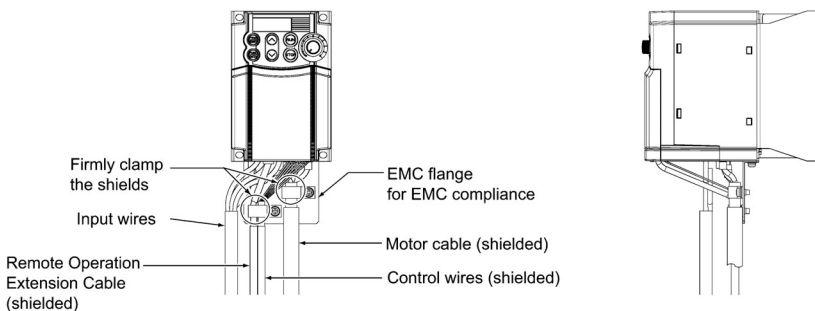



Figure 2.10 Grounding Shields to Comply with EMC Directives

 For EMC directives, refer to the FRENIC-Mini Instruction Manual (INR-SI47-0791-E), Chapter 11 "COMPLIANCE WITH STANDARDS."

Chapter 3 OPERATION USING THE REMOTE KEYPAD "TP-E1"

3.1 Familiarizing Yourself with the Remote Keypad

The Remote Keypad is composed of a 4-digit, 7-segment LED monitor, an LED display section consisting of 5 LEDs, and 6 keys as shown in Figure 3.1.

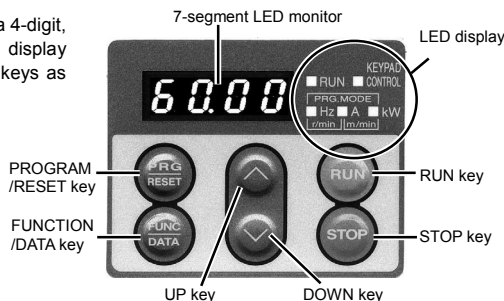

Figure 3.1 Overview of Remote Keypad

Table 3.1 Names and Functions of Various Parts of Remote Keypad

Group	Name	Function	Remarks
Data display	7-segment LED monitor	Displays the running status, data settings, alarm status, etc., depending on the operation mode.	*Operation mode: • Running mode • Programming mode • Alarm mode
Keys	key	Switches the operation mode*.	
	key	Depending on the operation mode, switches the information displayed, fixes the function code data, or switches the alarm information displayed.	
	key key	These keys are used to select the setting items displayed on the LED monitor and change the function code data.	
	key	Starts the motor.	
	key	Stops the motor.	
LED display	RUN LED	Lights when a Run command is given to the Inverter.	
	KEYPAD CONTROL LED	Lights when the inverter is operating under the Run command activated by the key.	
	3 unit LEDs	kW, A, Hz, r/min, m/min: These 3 LEDs together as a group indicate the unit of the quantity being monitored. ----- PRG. MODE: Two LEDs (right and left) light in Programming mode.	See Table 3.2.

For the operation mode of the FRENIC-Mini and its operating procedures, refer to the FRENIC-Mini Instruction Manual (INR-SI47-0791-E), Chapter 3 "OPERATION USING THE KEYPAD."

Table 3.2 lists the combinations of the three LEDs on the LED display, which indicate what is displayed on the 7-segment LED monitor.

Table 3.2 Definition of LEDs on the LED Display

Indication on LED	Unit	Description
■Hz □A □kW	Hz	Frequency
□Hz ■A □kW	A	Output current
□Hz □A ■kW	kW	Input power
■Hz ■A □kW	r/min	Load shaft speed
□Hz ■A ■kW	m/min	Line speed
■Hz □A ■kW	-	Programming mode







■: on, □: off

When data other than items above is displayed on the 7-segment LED monitor, all of three LEDs on the LED display are turned off. For details, refer to the FRENIC-Mini Instruction Manual (INR-SI47-0791-E), Chapter 3, Section 3.3 "Operation in Running Mode," (3) "Monitor the Running Status."

3.2 Operating the Remote Keypad



The functions and operations of the Remote Keypad are summarized in Table 3.3.

Table 3.3 Functions and Operations of Remote Keypad TP-E1

Function	Operation	Remarks
Run/Stop	Pressing the  key causes the motor to start rotation (forward/reverse); pressing the  key causes the motor to decelerate and stop.	For details, refer to the FRENIC-Mini Instruction Manual (INR-SI47-0791-E), Chapter 3 "OPERATION USING THE KEYPAD."
Set up	Pressing the  key or  key sets the set frequency and PID process command, and also sets the timer.	
Monitor the Running status	Items that can be monitored: speed, output current (A), output voltage (V), timer (s), input power (kW), PID process command, and PID feedback amount. <ul style="list-style-type: none"> ◆ In speed monitoring, one of the following can be selected: <ul style="list-style-type: none"> • output frequency (before slip compensation) (Hz), • output frequency (after slip compensation) (Hz), • set frequency (Hz) • load shaft speed (r/min), • line speed (m/min) • constant rate of feeding time (min). When an alarm condition has occurred, the cause of the trip is displayed as a code.	
Jogging the motor	The FRENIC-Mini is placed in the state that allows jogging operation using the  key and the  key.	
Data setting	The function code data is set up and confirmed.	
Data checking	Only the function codes that have been changed from the factory default are displayed or changed further.	
Drive monitoring	Various types of information for confirming the running status are monitored.	
I/O checking	The status of the interface with the outside world is monitored.	
Maintenance information	Certain items are checked or monitored during maintenance.	
Alarm information	Certain information such as alarm history is monitored and used in troubleshooting.	
Data copying	Function code data is read out, stored, or verified.	Refer to Section 3.3.

Note**Conflict between the Remote Keypad and the built-in keypad on the FRENIC-Mini**

When a Remote Keypad is connected to the FRENIC-Mini, the built-in keypad on the FRENIC-Mini is automatically disabled to avoid conflicts between them, with the following exceptions (for safety considerations).

When keypad operation is enabled (F02 = 0, 2, or 3) and the STOP key priority is selected (H96 = 1 or 3), the  key on the FRENIC-Mini is also enabled so that the FRENIC-Mini can be stopped by either  key. The  key on the FRENIC-Mini is also enabled to perform an alarm reset.

In any event, the 7-segment LED monitor on the FRENIC-Mini displays the same information as that on the Remote Keypad.

3.3 Data Copying

Menu #7 of "Data copying" allows you to read function code data out of FRENIC-Mini inverter (for which function codes have already been set up), to store the function code data block into another inverter, or to verify function code data. That is, this function compares the function code data saved in the Remote Keypad with that stored in the inverter.

The following conditions and restrictions apply to data copying:

■ Some function code data cannot be copied (stored) into another inverter.

For safety considerations, some function code data cannot be copied to another inverter if the specifications of the destination inverter are different from those of the source inverter. Which function code data can or cannot be copied is summarized in the FRENIC-Mini Instruction Manual (INR-SI47-0791-E), Chapter 5, the "Data copy" column of Section 5.1 "Function Code Tables," using the following designations:

Y : Can be copied unconditionally.

Y 1 : Cannot be copied if the rated capacity differs from the source inverter.

Y 2 : Cannot be copied if the rated input voltage differs from the source inverter.

N : Cannot be copied in any situation. (The function codes marked with N cannot be verified, either.)

Set up manually function code data that cannot be copied individually as necessary, by using Menu #1 "Data setting" in Programming mode.

■ If you cannot copy function code data:

Check whether the "*Err*" or "*CPEr*" indicator is blinking.

(1) "*Err*" is blinking ("Write error"): The following cases can be thought of:

- The memory of the Remote Keypad contains no data. (You have not read the memory since delivery or you have aborted a data read operation.)
- The memory of the Remote Keypad contains some invalid or abnormal data.
- The destination inverter type differs from the source inverter type.
- A write operation has been performed while the inverter is running.
- The inverter is in data protection mode.
- The "Enable editing of function code data from keypad" command (WE-KP) is off.

(2) "*CPEr*" is blinking: The following cases can be thought of:

- The function codes stored in the Remote Keypad are not compatible with those stored in the inverter. Non-standard function code data may have been stored, or the inverter may have been upgraded in an incompatible manner. Consult your Fuji Electric sales office.

Figure 3.2 shows the transition flow between different states of the inverter during data copying operation, while Table 3.4 shows details of the data copying functions. The memory of the Remote Keypad can save function code data for one inverter.

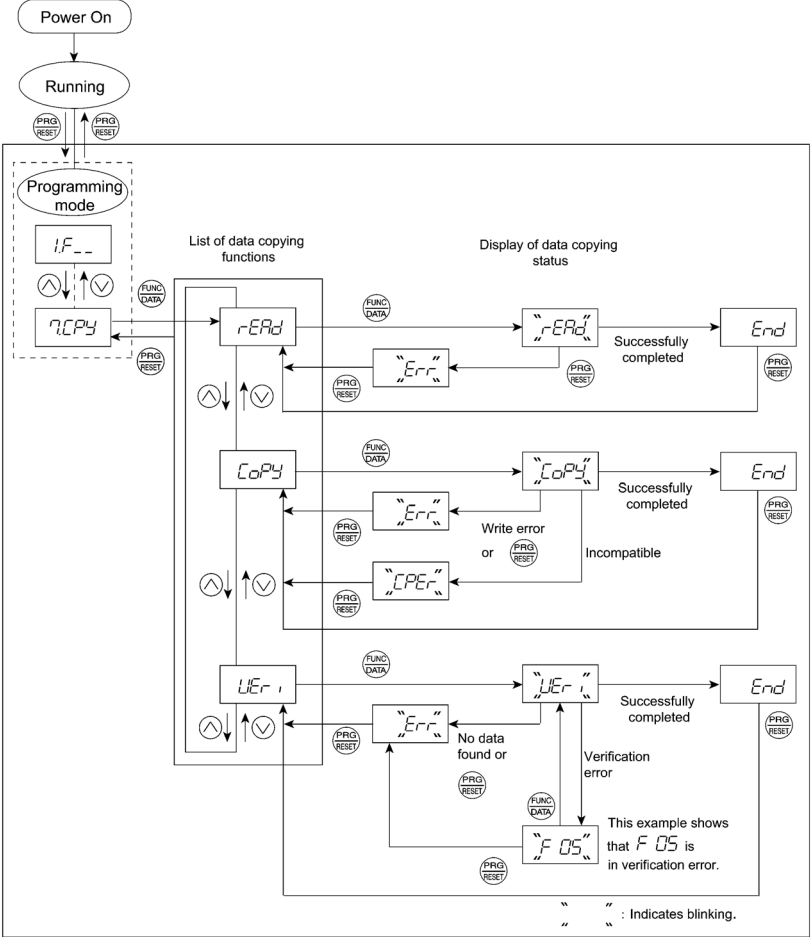

Figure 3.2 Status Transition during Data Copying

Basic key operation

If you cannot access all the menus, set function code E52 to "2" ("Full-menu mode").











- (1) On the initial menu, select "Data copying" by pressing the  key or  key several times until "7.CPy" is displayed.
- (2) Press the  key to switch to the List of data copying functions (for example, "rEAd" for a read operation).
- (3) Select the desired function by using the  key and  key and press the  key. The specified function will be carried out (for example, "rEAd" will blink).
- (4) When the specified function is successfully completed, "End" is displayed. To return to the List of data copying functions or the initial menu, press the  key once or twice, respectively.

Table 3.4 Data Copying Functions

LED monitor display	Function	Description
<i>rEAd</i>	Read data	Reads function code data from the inverter and saves it into the memory of the Remote Keypad. Pressing the  key during the read operation (while "rEAd" is blinking) aborts the read operation, causing "Err" to blink on the LED monitor (see Note) and the memory of the Remote Keypad to be cleared.
<i>CoPy</i>	Copy data	Writes the data stored in the memory of the Remote Keypad into the inverter. Pressing the  key during the write operation (while "CoPy" is blinking) aborts the write (copy) operation, causing "Err" to blink on the LED monitor (see Note) and function code data in the inverter memory to be incompletely modified. Do not run the inverter in such a state. Retry the write operation or initialize the inverter data. If you cannot perform a write (copy) operation, see " ■ If you cannot copy function code data ": on page 3-3.
<i>UEr 1</i>	Verify data	Compares the function code data stored in the memory of the Remote Keypad with that stored in the inverter. If any discrepancy is found, the verification is terminated, and the function code for which the discrepancy is found starts blinking on the LED monitor. Pressing the  key skips this function code; pressing it for the second time resumes the verification from the next function code. Pressing the  key during the verification (while "UEr 1" is blinking) aborts the verification, causing "Err" to blink on the LED monitor (see Note). "Err" is displayed also when there is no function code data in the memory of the Remote Keypad (see Note).

(Note) If "Err" or "CPEr" appears and blinks, press the  key to clear it.

Notes in data copying

- Do not disconnect the Remote Keypad from the inverter during data copying.

If you do so, the following problems will arise with the Remote Keypad and/or inverter depending upon the actual operation being in progress. Take the necessary action, following the instructions below.

If a data read operation (*rEAd*) was in progress:

The operation in progress is terminated. The read data stored in the memory of the Remote Keypad becomes invalid (the original data is lost). Data write and verify operations thereafter will result in a blinking "*Err*" display. Mount the Remote Keypad again and retry the read operation.

If a write operation (*CoPy*) was in progress:

The operation in progress is terminated. The function code data in the inverter memory is incompletely modified. Do not run the inverter in such a state. Mount the Remote Keypad again and retry the write operation or initialize the inverter data.

If a verify operation (*UEr t*) was in progress:

The operation in progress is terminated.

If there is no data or abnormal data stored in the memory of the Remote Keypad, the "*Err*" blinks on the monitor.

- If an error occurs in communication between the Remote Keypad and inverter during data copying, the "- - -" appears on the monitor and the following problems will arise with the Remote Keypad and/or inverter depending upon the actual operation being in progress. Take the necessary action, following the instructions below.

If a data read operation (*rEAd*) was in progress:

The operation in progress is terminated and "- - -" appears on the monitor. Once the read operation is terminated, the read data stored in the memory of the Remote Keypad becomes invalid (the original data is lost). Data write and verify operations thereafter will result in a blinking "*Err*" display.

When the communications error is removed, the Remote Keypad automatically enters the Running mode. So, retry the read operation at this point.

If a write operation (*CoPy*) was in progress:

The operation in progress is terminated and "- - -" appears on the monitor. The function code data in the inverter memory is modified incompletely. Do not run the inverter in such a state.

When the communications error is removed, the Remote Keypad automatically enters the Running mode. So, retry the write operation or initialize the inverter data.

If a verify operation (*UEr t*) was in progress:

The operation in progress is terminated and "- - -" appears on the monitor.

When the communications error is removed, the Remote Keypad automatically enters the Running mode.

Chapter 4 SPECIFICATIONS

4.1 General Specifications

Table 4.1 summarizes the general specifications of the Remote Keypad "TP-E1."

Table 4.1 General Specifications

Item	Specifications	Remarks
Enclosure	Front side: IP40; Rear side: IP20	
Environment	Indoor only.	
Ambient temperature (during operation)	-10 to +50°C	
Ambient humidity	5 to 95% RH (no condensation)	
Atmosphere	Shall be free from corrosive gases, flammable gases, dust, and direct sunlight.	
Altitude	1,000 m or below	(Note)
Atmospheric pressure	86 to 106 kPa	
Vibration	3 mm (max.) : 2 - 9 Hz 9.8 m/s ² : 9 - 20 Hz 2 m/s ² : 20 - 55 Hz 1 m/s ² : 55 - 200 Hz	
Ambient temperature (during storage)	-25 to +70°C	
Ambient humidity (during storage)	5 to 95% RH (no condensation)	
External dimensions	See the figure below.	
Mass	55 g	

(Note) If the Remote Keypad and the inverter are to be used at an altitude above 1,000 m (but below 3,000 m), the output current of the inverter must be lowered accordingly. For details, refer to the FRENIC-Mini Instruction Manual (INR-SI47-0791-E), Chapter 2, Section 2.1 "Operating Environment."

■ External dimensions

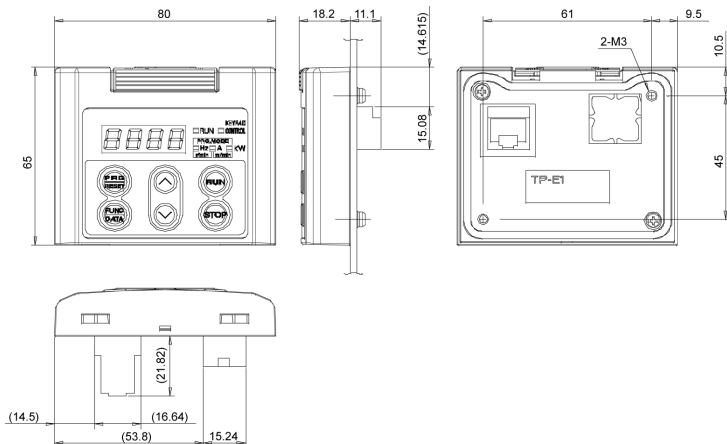

4.2 Communication Specifications

Tables 4.2 and 4.3 summarize the communication specifications.

Table 4.2 Hardware Specifications

Item	Specifications	Remarks
No. of inverters connected	One inverter for one Remote Keypad	
Connection cable	Shall meet the US ANSI/TIA/EIA-568A Category 5 standard (10BASE-T/100BASE-TX, straight).	Remote Operation Extension Cables are available as options (CB-5S, CB-3S, or CB-1S, depending on the distance).
Maximum communication distance	20 m	
Connector	RJ-45 connector	See Table 4.3.

Table 4.3 RJ-45 Connector Pin Assignment

Pin #	Signal name	Description	Remarks
1, 8	Vcc	DC power source for Remote Keypad	5 V
2, 7	GND	Signal ground	GND
3, 6	NC	Unassigned (reserved)	
4	DX -	RS485 communication data (-)	
5	DX +	RS485 communication data (+)	

Note) SW1 for the terminating resistor on the RS485 Communications Card must be set to OFF (open).

4.3 Transmission Specifications

Table 4.4 summarizes the transmission specifications.

Table 4.4 Transmission Specifications

Item	Specifications	Remarks
Area code	No need to specify.	There is no need to specify function codes y01 through y10 for RS485 communication, which will be ignored anyway.
Communication protocol	Modbus-RTU	
Synchronization system	Start-stop	
Communication system	Half-duplex	
Communication speed (Baud rate)	19,200 bps	
Parity	Even parity	
Stop bit length	1 bit	
Error checking	CRC-16	

Remote Keypad "TP-E1"

Instruction Manual

First edition, July 2003

Fuji Electric FA Components & Systems Co., Ltd.

The purpose of this manual is to provide accurate information in the handling, setting up and operating of Remote Keypad "TP-E1" for the FRENIC-Mini series of inverters. Please feel free to send your comments regarding any errors or omissions you may have found, or any suggestions you may have for generally improving the manual.

In no event will Fuji Electric FA Components & Systems Co., Ltd. be liable for any direct or indirect damages resulting from the application of the information in this manual.

Fuji Electric FA Components & Systems Co., Ltd.
