

Type R642 Second-Stage Regulator

Introduction

The Type R642 is an Underwriters Laboratories listed regulator designed for Two-Stage LP-Gas systems. The unit is designed to reduce the outlet pressure from a first-stage regulator (usually 10 psig (0,7 bar)) to an outlet pressure of 11-inches w.c. (27 mbar). The unit is capable of handling installations with up to 900,000 BTU/hr in required capacity. Its 90-degree body design makes the Type R642 ideal for metered installations. A screened drip-lip vent is oriented over the inlet in the standard configuration.

Features

- **20-Year Recommended Replacement Life**—The Type R642 is designed using rugged time proven design concepts and constructed of corrosion resistant materials, both internally and externally. With proper installation and periodic inspection and maintenance, the Type R642 regulator will meet a 20-Year Recommended Replacement Life.
- **Dual Gauge Taps**—Built in 1/8-inch threaded NPT gauge taps orifice to a number 54 drill size on the inlet and outlet side of the regulator allow for easy gas system checks.
- **Durability**—The design utilizes the durable valve stem linkage design used in R600 Series regulators for reliable lockup and regulation performance.
- **Improved Regulation**—A large fabric-reinforced diaphragm delivers accurate and stable regulation.
- **Easy Installation**—The units 90-degree body design make installation in metered systems easy. For bracketed mounted installations a standard bracket may be used. Optional vent orientation with the vent oriented over outlet is available.
- **Superior Overpressure Protection**—The combination of a high capacity relief valve and large vent provide overpressure protection which exceeds UL standards and is capable of limiting the downstream pressure to 2 psig (0,14 bar) even in a double failure situation when used with a Fisher brand Type R122H or R622H first-stage regulator.
- **Corrosion-Resistant**—Added corrosion resistance from an internal and external coating process for all castings prior to painting, stainless steel relief valve spring and retainer and a corrosion resistant relief valve seat.
- **Positive Draining Spring Case**—When installed properly with the spring case vent pointed down, the design allows moisture formed in the spring case to drain out limiting problems with corrosion and freezing water in the spring case.



Figure 1. Type R642 Second-Stage Regulator



Bulletin LP-7: R642

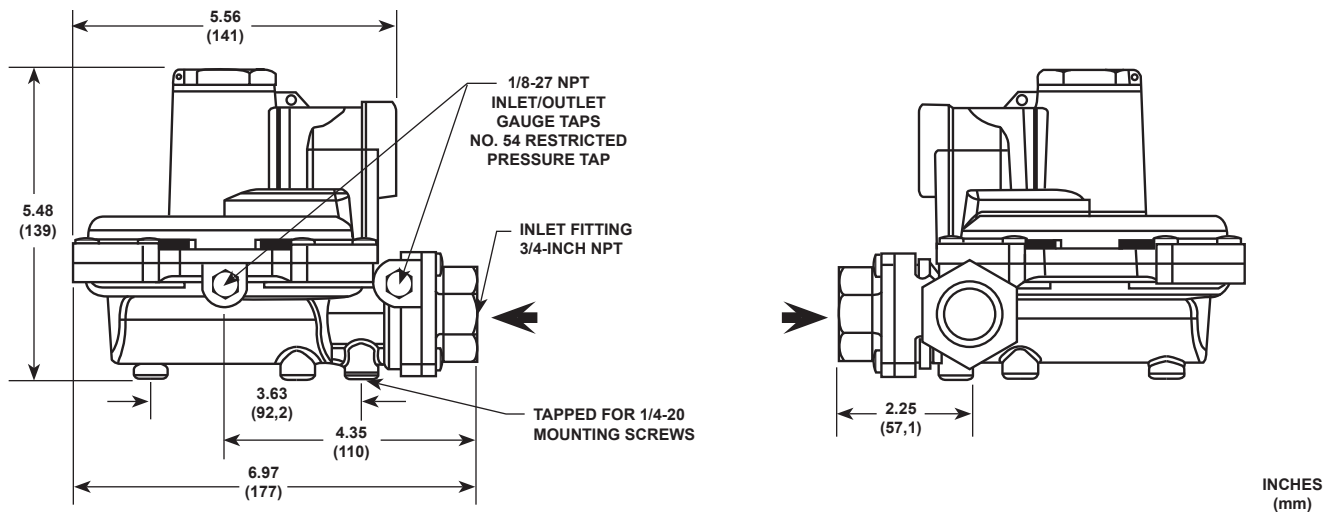

Figure 2. Type R642 Dimensions

Table 1. Ordering Information

TYPE NUMBER	CAPACITY BTU/HR PROPANE ⁽¹⁾	CONNECTIONS INLET X OUTLET	OUTLET PRESSURE SETTING	OUTLET PRESSURE RANGE
R642-DFF	900,000	3/4 x 3/4-inch NPT	11-inches w.c. (27 mabr)	9 to 13-inches w.c. (22 to 32 mbar)
R642-DFFXA ⁽²⁾				

1. Capacity is based on 10 psig (0,7 bar) inlet pressure and 2-inches w.c. (5 mbar) droop.
2. Spring case vent over outlet.

Fisher and Fisher Regulators are marks owned by Fisher Controls International, LLC. The Emerson logo is a trademark and service mark of Emerson Electric Co. All other marks are the property of their respective owners.

The contents of this publication are presented for informational purposes only, and while every effort has been made to ensure their accuracy, they are not to be construed as warranties or guarantees, expressed or implied, regarding the products or services described herein or their use or applicability. We reserve the right to modify or improve the designs or specifications of such products at any time without notice.

Fisher does not assume responsibility for the selection, use or maintenance of any product. Responsibility for proper selection, use and maintenance of any Fisher product remains solely with the purchaser.

Emerson Process Management

Fisher Controls International, LLC.

P.O. Box 8004
McKinney, Texas 75070, USA
Telephone: 1 (800) 558-5853
Telephone: 1 (469) 293-4201