

## Type R232A Integral Two-Stage Regulator

### Introduction

The Type R232A is an Underwriters Laboratories (UL®) listed regulator designed for LP-Gas systems. The unit is designed to reduce the tank pressure to an outlet pressure of 11 inches water column through an integral two-stage system. Designed for installations with small domestic loads. The units compact size makes it ideal for tight fit applications. The first-stage screened drip-lip vent is oriented downward and the second-stage vent is oriented over the outlet as standard.

### Features

- **20 Year Recommended Replacement Life** – The Type R232A is designed using rugged time proven design concepts and constructed of corrosion resistant materials, both internally and externally. With proper installation and periodic inspection and maintenance the Type R232A regulator will meet a 20 Year Recommended Replacement Life.
- **Dual Gauge Taps** – Built-in 1/8 inch NPT gauge taps orificed to a number 54 drill size on the intermediate and outlet side of the regulator allow for easy gas system checks.
- **Durability** – Design utilizes the same durable valve stem linkage design used in R600 Series regulators for reliable lockup performance.
- **Improved Regulation** – A large fabric-reinforced diaphragm delivers accurate and stable regulation.
- **Versatile Inlet Connections** – Inlet fitting is available in NPT and FPOL configurations.
- **Easy Installation** – The units compact size and easily accessible inlet and outlet wrench flats make installation easy even in the tightest installations.
- **Optional vent orientation** with both vents oriented opposite gauge taps available.
- **Superior Overpressure Protection** – The combination of a high capacity relief valve and large vent provide overpressure protection that exceeds UL standards.
- **Corrosion-Resistant** – Added corrosion resistance from an internal and external coating process for all castings prior to painting, stainless steel relief valve spring and retainer and a corrosion resistant relief valve seat.
- **Positive Draining Spring Case** – When installed properly with the spring case vents pointed down, the design allows moisture formed in the spring case to drain out limiting the problems with corrosion and freezing water in the spring case.

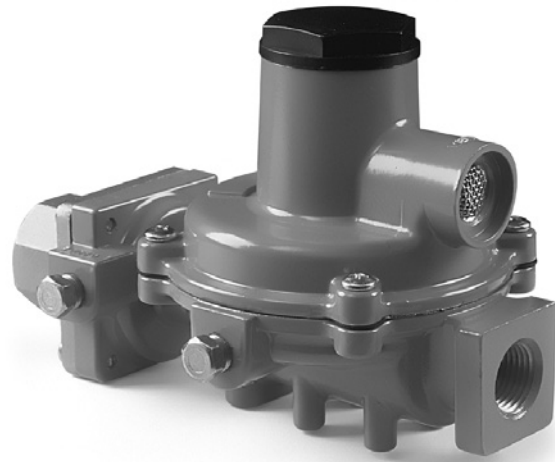

Figure 1. Type R232A Integral Two-Stage Regulator

Table 1. Selected Capacities for Type R232A Integral Two-Stage Regulators

OUTLET PRESSURE SETTING, SPRING RANGE	INLET PRESSURE		CAPACITY IN BTU/HR PROPANE <sup>(1)</sup>
	psig	bar	
11 inches w.c. / 27.4 mbar setting, 10.2 to 13 inches w.c. / 25 to 32.4 mbar spring range	25	1.72	520,000
	30	2.07	550,000
	100	6.90	640,000
	250	17.24	740,000

1. Capacities are based on 2 inches w.c. / 5.0 mbar droop.



# Bulletin LP-7: R232A

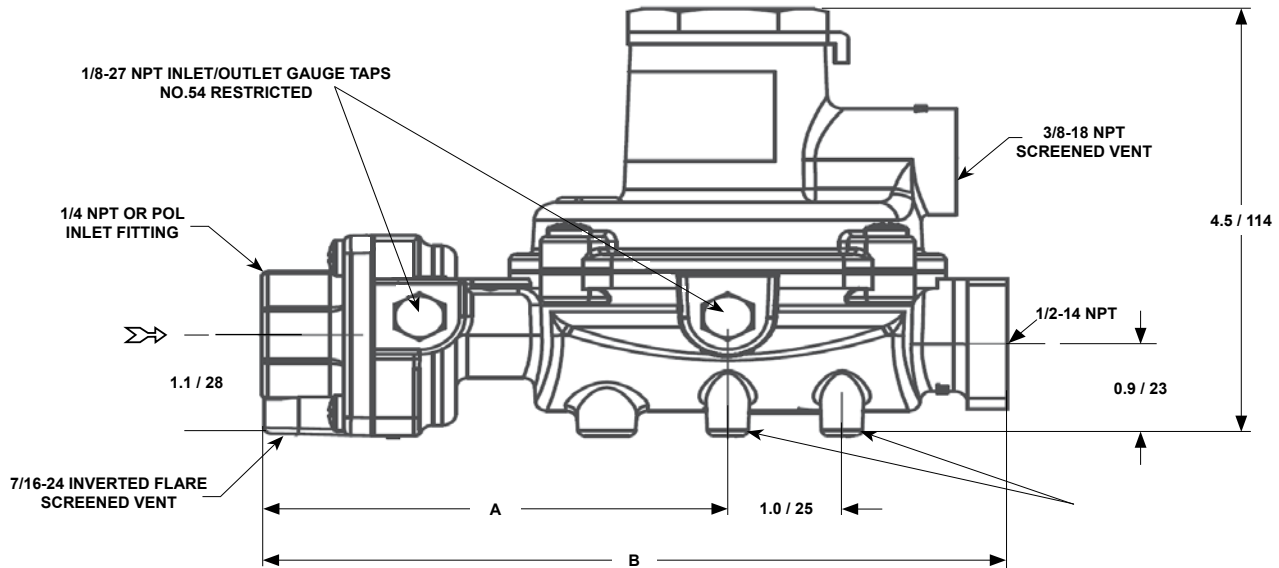

Figure 2. Type R232A Dimensions Inches / mm

Table 2. Type R232A Dimensions

INLET	A	B
1/4	4.06 / 103	6.51 / 165
POL	4.60 / 117	7.05 / 179

Table 3. Ordering Information

TYPE NUMBER	CAPACITY BTU/HR PROPANE <sup>(1)</sup>	CONNECTIONS INLET x OUTLET	OUTLET PRESSURE SETTING	OUTLET PRESSURE RANGE
R232A-BBF	550,000	1/4 inch x 1/2 inch FNPT	11 inches w.c. / 27 mbar	10.2 – 13 inches w.c. / 25 – 32 mbar
R232A-BBFXA <sup>(2)</sup>				
R232A-HBF		FPOL x 1/2 inch FNPT		
R232A-HBFXA <sup>(2)</sup>				

1. Capacity is based on 30 psig / 2.1 bar inlet pressure and 2 inches w.c. / 5 mbar droop.  
 2. First and second-stage spring case vents opposite gauge taps.

## LP-Gas Equipment

### Emerson Process Management Regulator Technologies, Inc.

USA - Headquarters  
 McKinney, Texas 75069-1872, USA  
 Tel: +1 800 558 5853  
 Outside U.S. +1 972 548 3574

For further information visit [www.fisherregulators.com](http://www.fisherregulators.com)

The Emerson logo is a trademark and service mark of Emerson Electric Co. All other marks are the property of their prospective owners. Fisher is a mark owned by Fisher Controls International LLC, a business of Emerson Process Management.

The contents of this publication are presented for informational purposes only, and while every effort has been made to ensure their accuracy, they are not to be construed as warranties or guarantees, express or implied, regarding the products or services described herein or their use or applicability. We reserve the right to modify or improve the designs or specifications of such products at any time without notice.

Emerson Process Management Regulator Technologies, Inc. does not assume responsibility for the selection, use or maintenance of any product. Responsibility for proper selection, use and maintenance of any Emerson Process Management Regulator Technologies, Inc. product remains solely with the purchaser.