

Type R222H First-Stage Regulator

Introduction

The Type R222H is an Underwriters Laboratories listed regulator designed for Two-Stage LP-Gas systems. The unit is designed to reduce the tank pressure to 10 psig / 0.69 bar or 5 psig / 0.35 bar inlet pressure to a second stage regulator. The compact size makes it ideal for small domestic applications and underground tanks. Screened drip-lip vents are oriented over the outlet as standard.

Features

- 20-Year Recommended Replacement Life –**
 The Type R222H is designed using rugged time proven design concepts with enhancements to the corrosion resistance and durability of materials both internally and externally. With proper installation and periodic inspection and maintenance, the Type R222H design has a 20-Year Recommended Replacement Life. In some environmental conditions, earlier replacement may be required.
- Improved Regulations –** A large fabric-reinforced diaphragm and stabilizer clip deliver accurate and stable regulation.
- Superior Overpressure Protection –** The combination of a high capacity relief valve and large vent provide overpressure protection which exceeds UL® standards. When used in conjunction with a

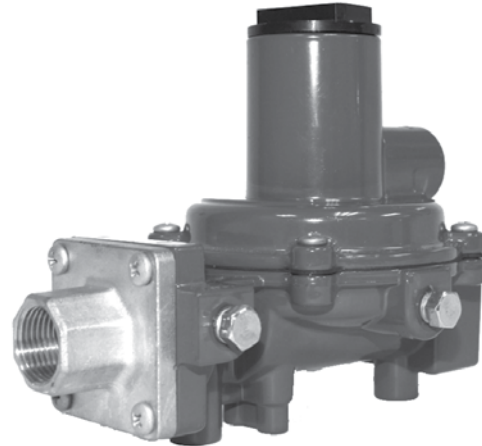

Figure 1. Type R222H First-Stage Regulator

Type R622 or R652 the two-stage system will limit the downstream pressure from the second-stage to 2 psig / 0.14 bar even in a double failure situation.

- Easy System Checks –** 1/8 in. NPT inlet and outlet gauge taps orificed to a number 54 drill size are easily accessible for gas system checks.
- Positive Drainage –** When installed properly with the spring case pointed down the Fisher® Positive Drainage design allows any moisture formed in the spring case to drain out eliminating the problems with corrosion and freezing of the water in the spring case.

Table 1. Ordering Information

TYPE	CAPACITY BTU/HR PROPANE ⁽¹⁾	CONNECTION INLET x OUTLET	OUTLET ADJUSTMENT SETTING		OUTLET PRESSURE RANGE	
			psig	bar	psig	bar
R222H-BGK	1,700,000	1/2 in. x 1/2 in. FNPT	5	0.35	4 to 6	0.28 to 0.41
R222H-BGJ	1,800,000		10	0.69	8 to 11.9	0.55 to 0.82
R222H-HGK	1,700,000	FPOL x 1/2 in. FNPT	5	0.35	4 to 6	0.28 to 0.41
R222H-HGJ	1,800,000		10	0.69	8 to 11.9	0.55 to 0.82
R222H-JGK	1,875,000	FPOL x 3/4 in. FNPT	5	0.35	4 to 6	0.28 to 0.41
R222H-JGJ	1,875,000		10	0.69	8 to 11.9	0.55 to 0.82
R222H-DGK	2,000,000	3/4 in. x 3/4 in. FNPT	5	0.35	4 to 6	0.28 to 0.41
R222H-DGJ	2,000,000		10	0.69	8 to 11.9	0.55 to 0.82

1. Capacities are based on 30 psig / 2.07 bar inlet pressure and 20% droop.

UL® is a mark owned by Underwriters Laboratories.



Bulletin LP-7:R222H

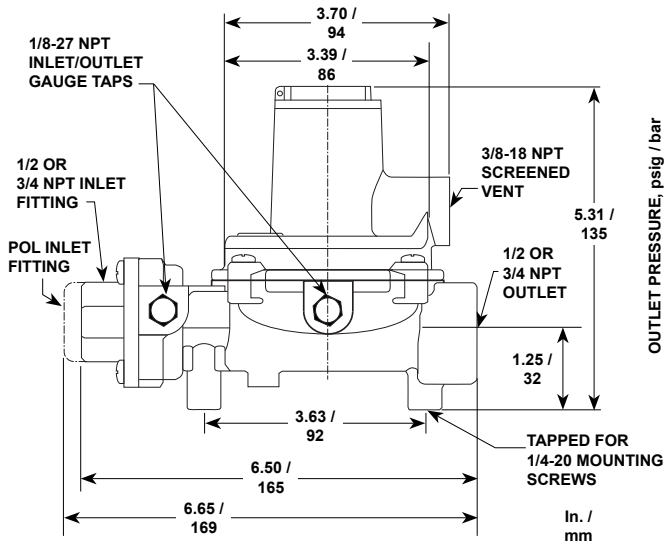

Figure 2. Type R222H Dimensions

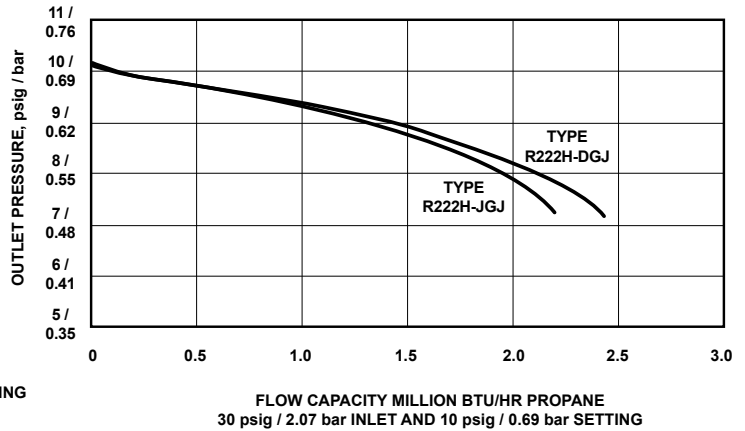

Figure 3. Flow Capacity Curves for Types R222H-JGJ and R222H-DGJ

Table 2. Selected Capacities for Type R222H First-Stage Regulators

OUTLET PRESSURE SETTING AND SPRING RANGE		INLET PRESSURE		CAPACITIES IN THOUSANDS BTU/HR PROPANE ⁽¹⁾		
psig	bar	psig	bar	1/2 x 1/2 and FPOL x 1/2	FPOL x 3/4	3/4 x 3/4
5 4 to 6	0.35 0.28 to 0.41	20	1.38	1400	1550	1750
		25	1.72	1600	1750	1850
		30	2.07	1700	1875	2000
		50	3.45	2460	2950	3180
		100	6.90	2950	4790	5010
10 8 to 11.9	0.69 0.55 to 0.82	20	1.38	1430	1500	1580
		25	1.72	1620	1750	1895
		30	2.07	1800	1875	2000
		50	3.45	2650	3030	3250
		100	6.90	3900	5200	5350

1. Capacities are based on 20% droop.

LPG Equipment

Emerson Process Management Regulator Technologies, Inc.

USA - Headquarters
McKinney, Texas 75070 USA
Tel: +1 800 558 5853
Outside U.S. +1 972 548 3574

For further information visit www.fisherregulators.com

The Emerson logo is a trademark and service mark of Emerson Electric Co. All other marks are the property of their prospective owners. Fisher is a mark owned by Fisher Controls International LLC, a business of Emerson Process Management.

The contents of this publication are presented for informational purposes only, and while every effort has been made to ensure their accuracy, they are not to be construed as warranties or guarantees, express or implied, regarding the products or services described herein or their use or applicability. We reserve the right to modify or improve the designs or specifications of such products at any time without notice.

Emerson Process Management Regulator Technologies, Inc. does not assume responsibility for the selection, use or maintenance of any product. Responsibility for proper selection, use and maintenance of any Emerson Process Management Regulator Technologies, Inc. product remains solely with the purchaser.