

## 67C Series High-Pressure Regulators

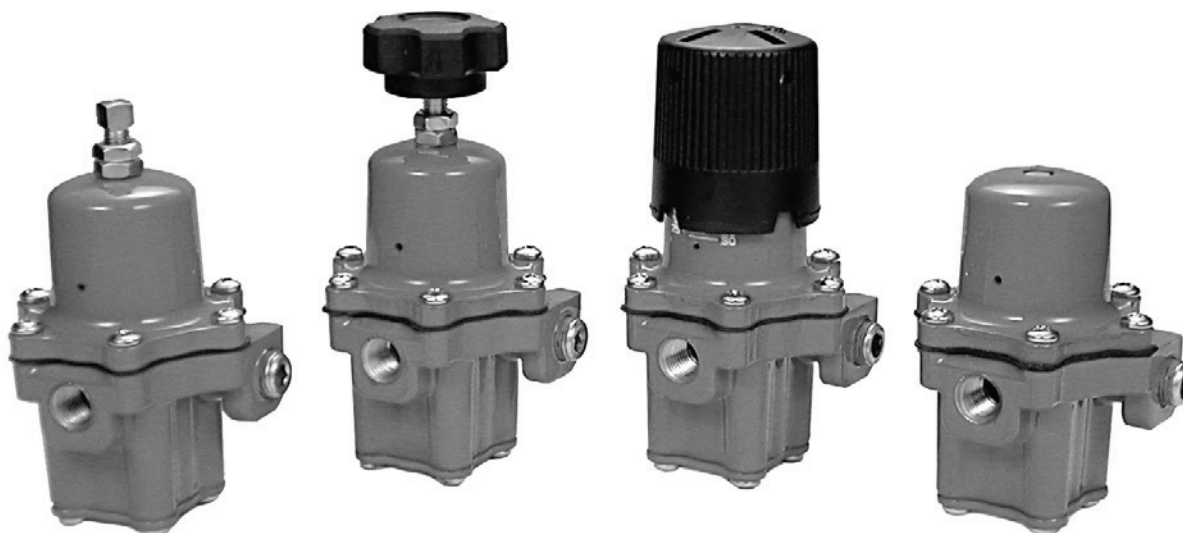

W8810

**Figure 1.** 67C Series Regulators

### Introduction

The 67C Series high-pressure regulators meet a variety of applications in liquid or vapor service. The compact body design makes the 67C Series particularly useful in installations with space limitations.

The basic 67C Series regulator comes equipped with a wrench or handwheel adjustment (67CW or 67CH Series). The highly accurate 67CD Series eliminates the need for a pressure gauge on portable applications by using calibrated scales on the spring case, allowing visual adjustment of outlet pressure. The non-adjustable 67CN Series provides a tamper-resistant spring case and one of three fixed setpoints: 10, 15, or 20 psi (0,69; 1,0; or 1,4 bar).

The 67C Series carries a UL listing as a high-pressure, non-relief regulator. This series contains brass materials that are not compatible with anhydrous ammonia service.

### Features

- **Compact**
- **High Stability**
- **UL Listed**



# Bulletin LP-7:67C

## Specifications

<p><b>Maximum Allowable Inlet Pressure</b> 250 psig (17,2 bar)</p> <p><b>Maximum Emergency Outlet Pressure</b> 50 psig (3,4 bar) above outlet pressure setting</p> <p><b>Temperature Capabilities</b> -40° to 180°F (-40° to 82°C)</p> <p><b>Outlet Pressure Range</b> See Table 1</p>	<p><b>Body Size and End Connection Style</b> 1/4-inch FNPT</p> <p><b>Spring Case Vent Location</b> Aligned over inlet</p> <p><b>Options</b></p> <ul style="list-style-type: none"> <li>• Wrench Adjustment</li> <li>• Handwheel Adjustment</li> <li>• Dial Cap Adjustment</li> <li>• Tamper-Resistant, Non-Adjustable Spring Case</li> <li>• Outlet Pressure Gauge</li> </ul>
--	---

**Table 1. Regulator Specification and Ordering Information**

OUTLET PRESSURE SETTING, PSIG (bar)	SPRING RANGE, PSIG (bar)	INLET AND OUTLET CONNECTIONS	CAPACITY IN BTU/HR OF PROPANE <sup>(1)</sup>	ADJUSTMENT STYLE AND TYPE NUMBER	
				Wrench	Handwheel
----	----	1/4-inch FNPT	----		
15 (1,0)	3 to 20 (0,21 to 1,4)		675 000	67CW-683	67CH-751
20 (1,4)	3 to 35 (0,21 to 2,4)		750 000	67CW-684	67CH-743
40 (2,8)	30 to 60 (2,1 to 4,1)		1 200 000	67CW-685	67CH-742
50 (3,4)	50 to 135 (3,4 to 9,3)		1 000 000	67CW-701	67CH-741
----	----		----	<b>Dial Cap</b>	
15 (1,0)	5 to 20 (0,34 to 1,4)		675 000	67CD-100	
40 (2,8)	20 to 50 (1,4 to 3,4)		1 200 000	67CD-102	
50 (3,4)	40 to 100 (2,8 to 6,9)		1 000 000	67CD-103	
----	----		----	<b>Non-Adjustable</b>	
10 (0,69)	Non-Adjustable		400 000	67CN-106	
15 (1,0)			600 000	67CN-104	
20 (1,4)			750 000	67CN-105	

1. Based on inlet pressure 20 psig (1,4 bar) greater than outlet with 20% droop. Liquid capacity equals 3 to 5 GPH (11,4 to 18,9 l/h).

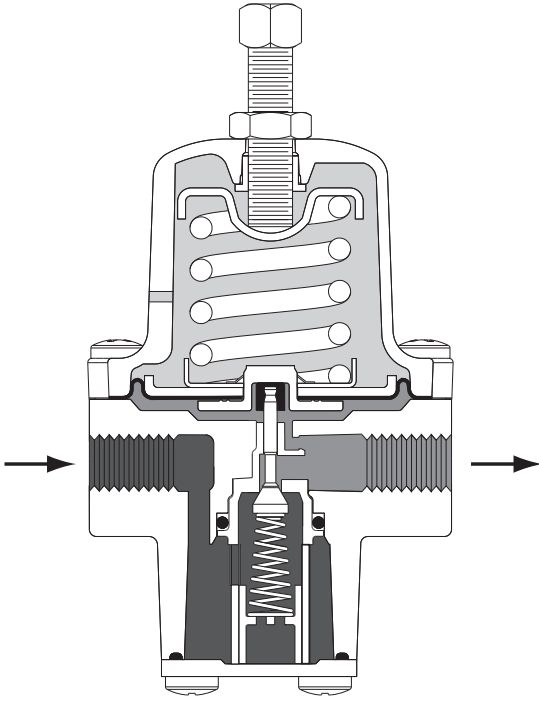

TYPE 67C

W8442

- INLET PRESSURE
- OUTLET PRESSURE
- ATMOSPHERIC PRESSURE

Figure 2. 67C Series Regulator Operational Schematic

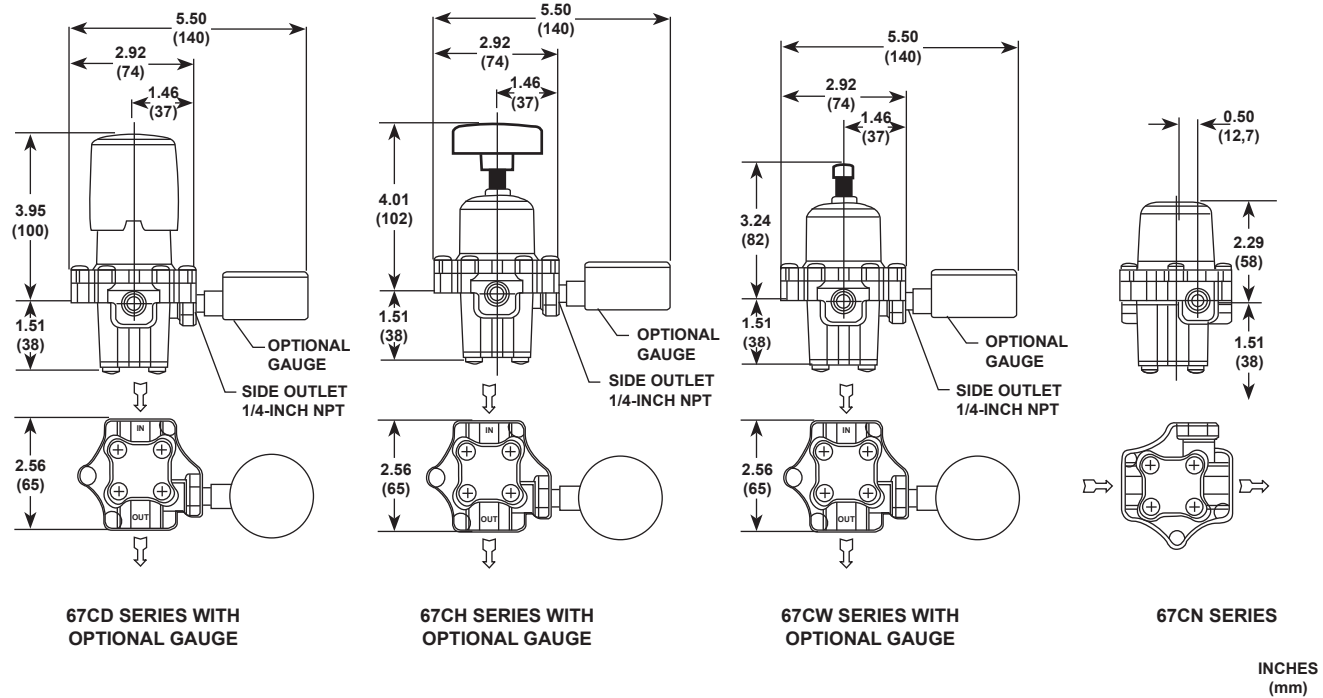

Figure 3. 67C Series Regulator Dimensions

# Bulletin LP-7:67C

---

## LP-Gas Equipment

### Emerson Process Management Regulator Technologies, Inc.

USA - Headquarters  
McKinney, Texas 75069-1872 USA  
Telephone: 1 (800) 558-5853  
Telephone: 1 (972) 548-3574

For further information visit [www.fisherregulators.com/lp](http://www.fisherregulators.com/lp)

The Emerson logo is a trademark and service mark of Emerson Electric Co. All other marks are the property of their prospective owners. Fisher is a mark owned by Fisher Controls, Inc., a business of Emerson Process Management.

*The contents of this publication are presented for informational purposes only, and while every effort has been made to ensure their accuracy, they are not to be construed as warranties or guarantees, express or implied, regarding the products or services described herein or their use or applicability. We reserve the right to modify or improve the designs or specifications of such products at any time without notice.*

Emerson Process Management does not assume responsibility for the selection, use or maintenance of any product. Responsibility for proper selection, use and maintenance of any Emerson Process Management product remains solely with the purchaser.