

SPOOL PIECE ULTRASONIC FLOWMETER FOR HAZARDOUS LOCATION

DATA SHEET
FST

FST is an in-line ultrasonic flowmeter with three parallel measuring paths. With the latest digital signal processing technology and the calculation algorithm, it can deliver highly precise flow measurement. HART or RS-485 communication is also available as option.

FEATURES

1. High accuracy: $\pm 0.2\%$ of rate
Using the new algorithm for calculating the flow velocity, it can measure any type of fluid with high accuracy.
2. Low maintenance
With no moving parts, it has long-term stability while requiring only minimal maintenance work.
3. Bubble resistant
By using the advanced anti-bubble measurement technology, the interference from air bubbles is greatly eliminated.
4. For any liquid from -10°C to $+150^{\circ}\text{C}$
Non conductive fluid including oil, mixed liquid, purified water can be measured.
5. Easy-to-operate
 - Backlit LCD and front keys
 - Troubleshooter provided
 - Can be vertically or horizontally installed

SPECIFICATIONS

1. General specifications

- **Measuring principle:**
Transit time difference method
Parallel 3-path with the advanced ABM (anti-bubble measurement) system
- **Diameter (mm):**
25 (under development), 50, 80, 100
- **Flow velocity range:**
Minimum 0 to 0.3 m/s or -0.3 to 0 m/s
Maximum 0 to 10 m/s or -10 to 0 m/s
- **Flow range:**

Diameter (mm)	25	50	80	100
Minimum (m ³ /h)	0 to 0.54	0 to 2.13	0 to 4.65	0 to 7.99
Maximum (m ³ /h)	0 to 17.6	0 to 70.6	0 to 154.8	0 to 266.0
- **Dimensions and weight:**
Refer to outline diagram
- **Power supply:**
100-240 V AC (+10% -15%), 50/60 Hz
20-30 V DC (under development)
- **Power consumption:**
Approx. 20 VA (AC power)
Approx. 6 W (DC power)
- **Grounding:**
A-class grounding with ground resistance of 10 Ω or less
- **Varistor:**
Attached to the power supply port



- **Surge arrester:**
Attached to the analog output port
- **Enclosure:**
IP67
- **Ambient temperature:**
 -10°C to $+60^{\circ}\text{C}$
- **Ambient humidity:**
90% RH or less
- **Vibration tolerance:**
1 G, 10–200 Hz

2. Fluid conditions

- **Applicable fluid:**
Liquid (uniform liquid through which ultrasonic wave can propagate; and liquid that won't corrode stainless steel 316)
- **Bubble content:**
 ≤ 12 vol%
- **Turbidity:**
10,000 mg/L or less
- **Flow profile:**
fully-developed turbulent or laminar flow in a fully-filled pipe
- **Temperature:**
 -10°C to $+150^{\circ}\text{C}$
- **Pressure:**
Up to flange rating
- **Kinematic viscosity:**
 ≤ 100 mm²/s

3. Detector

- **Wetted parts material:**
Flow cell: stainless steel 316L
Flange: stainless steel 316L
Sensor wetted parts: stainless steel 316L

- **Detector material:**
Housing: SCS13
- **Process connections:**
Flange (horizontal or vertical mounting)
- **Flange rating:**
JIS10K/JIS20K
ANSI class 150/300
DIN PN16/40

4. Performance

- **Accuracy:**
 - Reading and pulse output:
 - ±0.2% of rate (flow velocity 1 m/s to 10 m/s)
 - ±0.002 m/s (flow velocity 0.5 m/s to 1 m/s)
 - Analog output:
 - Above indicated accuracy ±0.01 mA (at the ambient temperature of 25°C)
- **Reference condition:**
 - Fluid: water
 - Straight run requirements: 10D on inlet side
5D on outlet side
(D: pipe diameter)
 - Measurement period: 600s
 - Pipe wall thickness: schedule 40
 - Fluid temperature: 0°C to 35°C
- **Response time:**
1.2 s (standard)

5. Flow transmitter

- **Analog output signal:**
4–20 mA DC (insulated), 1 point
Allowable load resistance: ≤ 600Ω
- **Contact output:**
Forward total, reverse total, alarm, acting range, flow switch, or total switch
User configurable
 - Type: transistor output (isolated, open collector)
 - Contact capacity: 30 V DC, 50 mA
 - 2 points
 - Normal: ON or OFF, selectable
 - Frequency: 100 P/s max.
(Pulse width: 5, 10, 50, 100, 200, 500, 1000 ms)
- **Communication (option):**
 - RS-485 (MODBUS), isolated, arrester incorporated
No. of connectable modules: up to 31
Baud rate: 9600, 19200, 38400 bps
Parity: none/odd/even, selectable
Stop bit: 1 or 2 bit, selectable
Cable length: up to 1 km
Data: Flow velocity, flow rate, forward total, reverse total, status, etc.
 - HART
Transmission distance: up to 1 km (when the wire with the following specifications is used)
Capacitance: ≤ 0.07 μF/km
Conductor resistance: ≤ 17.8 Ω/km
Load resistance: 250 Ω to 600 Ω
- **Display:**
16-digit 2-line backlit LCD
2-color LED (green: normal, red: at error)
- **Language:**
Japanese (katakana), English, French, German, Spanish (switchable)

- **Flow velocity/flow rate indication:**
8 digits numerals (decimal point is counted as 1 digit)
Instantaneous flow rate, instantaneous flow velocity (minus indication for reverse flow)
Unit:

Flow velocity	m/s
Flow rate	L/s, L/min, L/h, L/d, kL/d, ML/d, m³/s, m³/min, m³/h, m³/d, km³/d, Mm³/d

- **Total value indication:**
Integrated value of forward flow or reverse flow (reverse flow is indicated with minus symbol)
8 digits numerals (decimal point is counted as 1 digit)
Unit: mL, L, m³, km³, Mm³
- **Housing material:**
Aluminum alloy
- **Coating:**
Urethane resin
- **Finish color:**
Silver
- **Wiring port:**
M20 internal thread
Either of the followings are provided:
 - M20 × 1.5 blind plugs
 - Cable glands with pressure-proof packing
- **Terminal:**
Euro-style terminal

6. Functional specifications

- **Setting**
By using 4 keys (ESC, △, ▽, ENT)
- **Zero point adjustment:**
By setting zero or clearing zero
- **Damping:**
For analog output or velocity/flow rate indication, 0 to 100 seconds
(In 1-second steps)
- **Low flow cut-off:**
0 to 5 m/s in terms of flow velocity
- **Alarm:**
For hardware error or process error
Contact output available
- **Output burnout:**
Analog output: hold, overscale, underscale, or zero
Flow rate total: hold or count
Burnout timer: 0 to 100 seconds (in 1-second steps)
- **Output limit:**
High/low limit for analog output is available in the range from 0.8 mA to 23.2 mA
- **Bi-directional range:**
Forward and reverse ranges configurable independently.
Hysteresis: 0% to 20 % of working range
Working range applicable to digital output.
- **Auto 2 range:**
Two ranges configurable independently
Hysteresis: 0% to 20 % of working range
Working range applicable to digital output.
- **Flow switch:**
High limit and low limit are configurable independently
Contact output can be activated while the instantaneous flow rate is beyond the high/low limit.
- **Total switch:**
High limit for total flow
Contact output can be activated when the total flow has exceeded the high limit.
- **Total preset:**
Total flow returns to the user-defined preset value every time a user resets the total.

- **Data backup at power outage**
on nonvolatile memory

7. EU Directive Compliance (CE)

LVD (2014/35/EU)

EN 61010-1

EMC (2014/30/EU)

EN 61326-1 (Table 2)

EN 55011 (Group 1 Class A)

EN 61000-3-2 (Class A)

EN 61000-3-3

EN 61326-2-3

RoHS (2011/65/EU)

EN 50581

8. Ex-proof certifications

Certification	Ex-proof specification
ATEX	Certificate number : CML 17ATEX1032X Ex db ia[ia Ga] II C T4 Ga/Gb Ambient temperature : -10°C to +60°C
IECEX	Certificate number : IECEx CML 17 .0017X Ex db ia[ia Ga] II C T4 Ga/Gb Ambient temperature : -10°C to +60°C
Japanese explosion-proof certification	Certificate number: CML 17JPN1326X Ex d ia[ia Ga] II C T4 Ga/Gb Ambient temperature : -10°C to +60°C
NEPSI	Ex db ia[ia Ga] II C T4 Ga/Gb Ambient temperature : -10°C to +60°C
Temperature class	Maximum fluid temperature
T4	130°C
T1 to T3	150°C

■ Parameter loader software (RS-485 communication)

Provided as a standard accessory.

- For IBM PC compatible
- Allows a user to configure or to change parameter values.
- Supported OS:
Windows 7 (Home Premium, Professional), Windows 8 (Professional), Windows 10 (Enterprise)
- Memory:
≥ 128 MB
- Drive:
CO-ROM drive compatible with Windows 7 (Home Premium, Professional), Windows 8 (Professional), Windows 10 (Enterprise)
- Hard-disk space:
≥ 52 MB

Note 1) To use serial communication, select "D" in 10th code.

Note 2) Communication interface converter:

For a PC which supports the RS-232C serial interface, a RS232C to RS485 converter is required.

If your PC does not support the RS232C serial interface, an USB to RS232C converter is additionally required.

<Recommended products>

RS232C to RS485 converter:

OMRON K3SC-10 interface converter (insulated)

*A D-sub connector cable is required.

USB to RS232C converter:

SANWA SUPPLY USB-CVRS

CHECK BEFORE ORDER

In the following conditions, the flowmeter may not be able to deliver enough accuracy or the measurement may be unavailable.

Consult us if you have any concerns. We can arrange a trial measurement before order.

1. Liquid

- Liquid contains a large amount of bubbles (12 vol% or more, at a flow rate of 1 m/s)

For example : circulating oil

- Liquid has a turbidity of 10000 mg/L or more

For example: waste liquid, hot spring water

- Liquid contains slurry and/or solid matters (about 5 wt%)

For example: waste liquid, hot spring water

- Low Reynolds number (10000 or less)

(Flow rate of 5 m³/h, in a 100-mm diameter pipe)

*Flow rate is proportional to diameter

- Liquids that can corrode pipe inner surface

For example: chemical solutions, liquid that contains solid matters

- High viscosity liquid (kinematic viscosity of 200 mm²/s or more)

2. Pipe straight run

For accurate measurement, a certain length of straight run is required. Check if it is possible to meet the straight run requirements given in Page 4.

PRINCIPLE

Parallel 3-path measurement

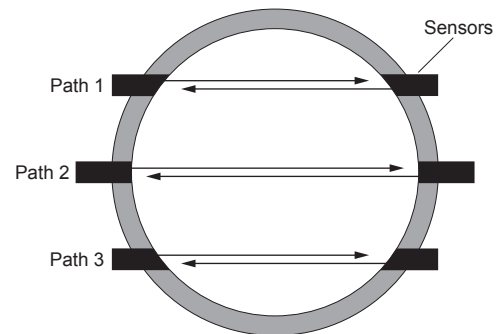

By measuring the flow with three parallel paths simultaneously, and averaging them, the flowmeter obtains the flow rate with ±0.2% of rate accuracy.

PIPE REQUIREMENTS

(D: inside diameter of pipe)

	Upstream	Downstream
90° bend	<p>$\geq 10D$</p> <p>$\geq 10D$</p>	<p>$\geq 5D$</p>
T-shaped pipe	<p>$\geq 10D$</p> <p>$\geq 50D$</p>	<p>$\geq 10D$</p>
Expanding pipe	<p>$\geq 0.5D$</p> <p>$\geq 1.5D$</p> <p>$\geq 30D$</p>	<p>$\geq 5D$</p>
Tapered pipe	<p>$\geq 10D$</p>	<p>$\geq 5D$</p>
Valves	<p>$\geq 30D$</p> <p>In the case where a flow control valve exists on upstream side</p>	<p>$\geq 10D$</p> <p>In the case where a flow control valve exists on downstream side</p>
Pump	<p>Check valve</p> <p>Gate valve</p> <p>Gate valve</p>	

(Note)The source : JEMIS-032

CODE SYMBOLS

Digit	Description	FST	← Digit													
			4	5	6	7	8	9	10	11	12					
4	<Enclosure> ATEX/IECEX Japanese Ex certification NEPSI						1									
5	<Diameter> 25A (under development) 50A 80A 100A			A D F G												
6	<Flange rating and material> JIS 10K / SS 316L JIS 20K / SS 316L ANSI 150LB / SS 316L ANSI 300LB / SS 316L DIN PN16 / SS 316L DIN PN40 / SS 316L						1 2 3 4 5 6									
7	<Power Supply> 100–240 V AC, 50/60 Hz 20–30 V DC (under development)						1 4									
8	<Revision code>						1									
9	<Parameter setting / tag plate> None With setting With setting + tag With tag									Y A B C						
10	<Communication> None RS-485 HART										Y D H					
11	<Mounting / wiring port position> Horizontal / on downstream side Horizontal / on upstream side Horizontal / on the right side seen from upstream Horizontal / on the left side seen from upstream Vertical / on bottom side (flow is upward)											A B C D E				
12	<Wiring port> Three M20 × 1.5 blind plugs (4th code 2 or 4) Two cable glands with pressure-proof packing (4th code 3) Three cable glands with pressure-proof packing (4th code 3)	Note Note											B C D			

Note) The number of cable glands for Japanese ex-proof version

The 12th code "C"

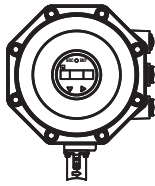

AO, DO, or AO & DO
Power supply (AC or DC)

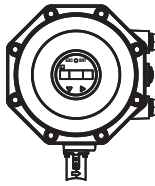

RS-485 or HART (AO)*
Power supply (AC or DC)

*Shielded twisted pair cable

The 12th code "D"

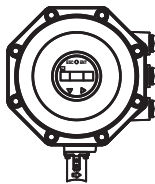

RS-485*
AO, DO, or AO & DO
Power supply (AC or DC)

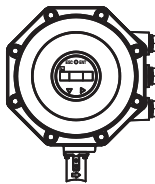

HART (AO)*
DO
Power supply (AC or DC)

*Shielded twisted pair cable

If you need only one cable gland, consult us.

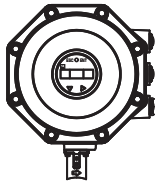

Power supply (AC or DC)

OUTLINE DIAGRAM (Unit : mm)

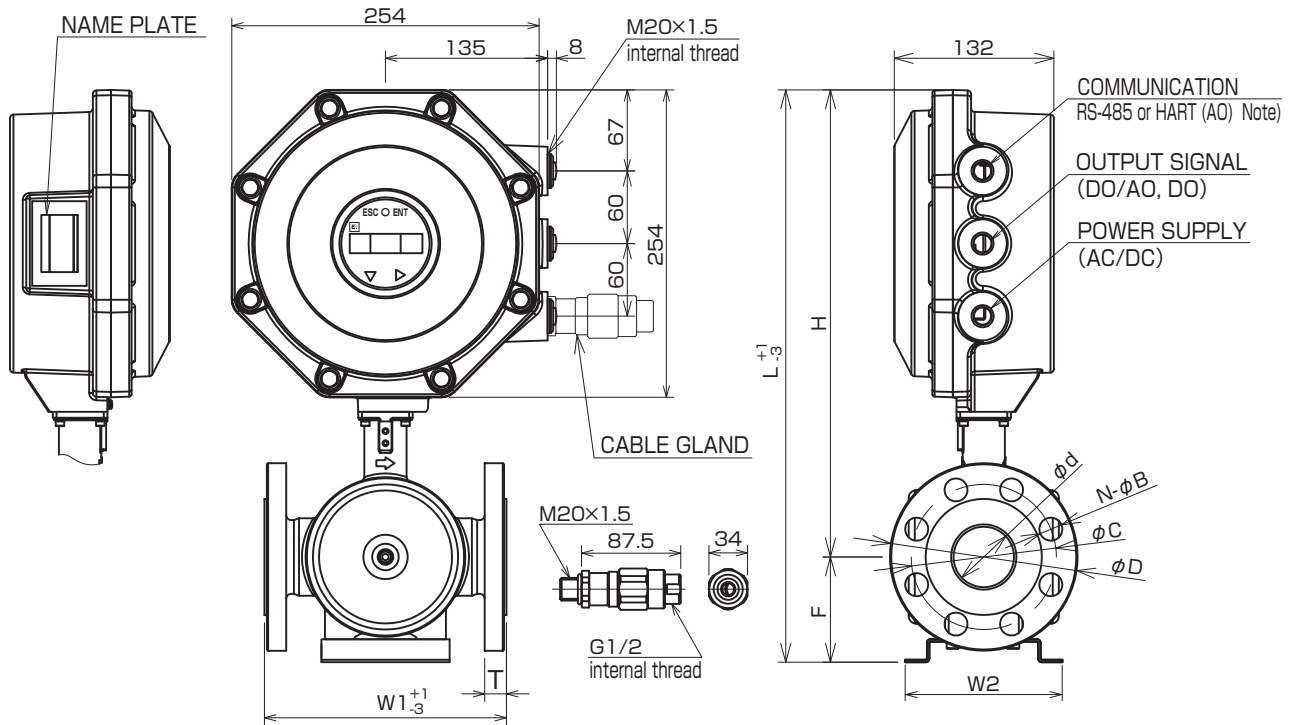

BODY DIMENSIONS

PIPE SIZE	25A	50A	80A	100A
W1	200	200	300	300
W2	130	130	160	160
ϕd	25	50	74	97
H	375	386	398	409
F	84	87	120	129
L	459	473	518	538

Notes on wiring port for HART communication

For HART communication, use a shielded twisted pair cable and connect it through the HART (AO) port to the AO terminals. Do not use the output signal port for HART communication.

WIRING PORT	HART		RS-485	
	YES	NONE	YES	NONE
COM.	HART (AO)	UNUSED	RS-485	UNUSED
OUTPUT SIG.	DO	AO, DO	AO, DO	AO, DO

FLANGE DIMENSIONS (6th DIGIT)

PIPE SIZE		25A	50A	80A	100A
JIS 10K FLANGE (CODE: 1)	ϕD	125	155	185	210
	ϕC	90	120	150	175
	$N-\phi B$	4-19	4-19	8-19	8-19
	T	14	16	18	18
	MASS. (kg)	14	17	22	27
ANSI 150LB FLANGE (CODE: 3)	ϕD	110	150	190	229
	ϕC	79.4	120.7	152.4	190.5
	$N-\phi B$	4-15.9	4-19.1	4-19	8-19
	T	14.3	19.1	23.9	23.9
	MASS. (kg)	14	17	25	31
DIN PN16 FLANGE (CODE: 5)	ϕD	115	165	200	220
	ϕC	85	125	160	180
	$N-\phi B$	4-14	4-18	8-18	8-18
	T	16	18	20	20
	MASS. (kg)	15	18	25	28

PIPE SIZE		25A	50A	80A	100A
JIS 20K FLANGE (CODE: 2)	ϕD	125	155	200	225
	ϕC	90	120	160	185
	$N-\phi B$	4-19	8-19	8-23	8-23
	T	16	18	22	24
	MASS. (kg)	14	17	25	30
ANSI 300LB FLANGE (CODE: 4)	ϕD	125	165	210	254
	ϕC	88.9	127	168.1	200
	$N-\phi B$	4-19.1	8-19.1	8-22	8-22
	T	17.5	22.3	28.6	31.8
	MASS. (kg)	16	19	29	39
DIN PN40 FLANGE (CODE: 6)	ϕD	115	165	200	235
	ϕC	85	125	160	190
	$N-\phi B$	4-14	4-18	8-18	8-22
	T	18	20	24	24
	MASS. (kg)	16	19	26	32

CONNECTION DIAGRAM

(1) Power supply

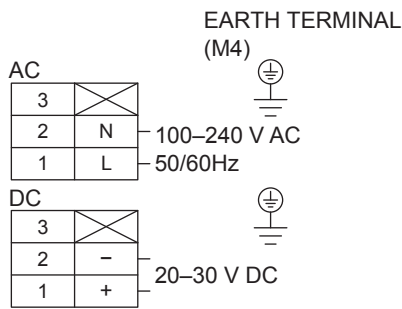

(2) Output

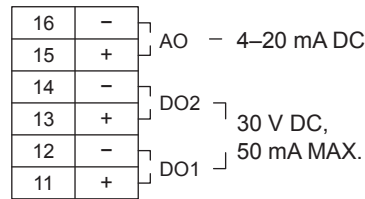

(3) RS-485 (option)

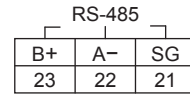

Allowable wire

- Wire
Size: AWG20 (0.5 mm²) to AWG16 (1.5 mm²)
Strip length: 8-10 mm

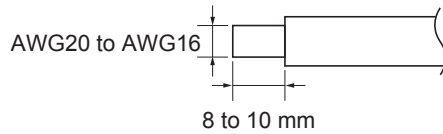

- Recommended wire ferrule
Weidmueller
<http://www.weidmuller.com>
Wire end ferrule with insulating collar

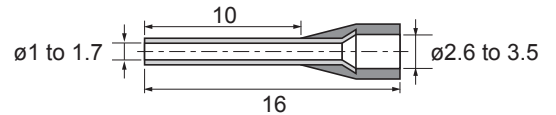

MOUNTING/WIRING PORT POSITION

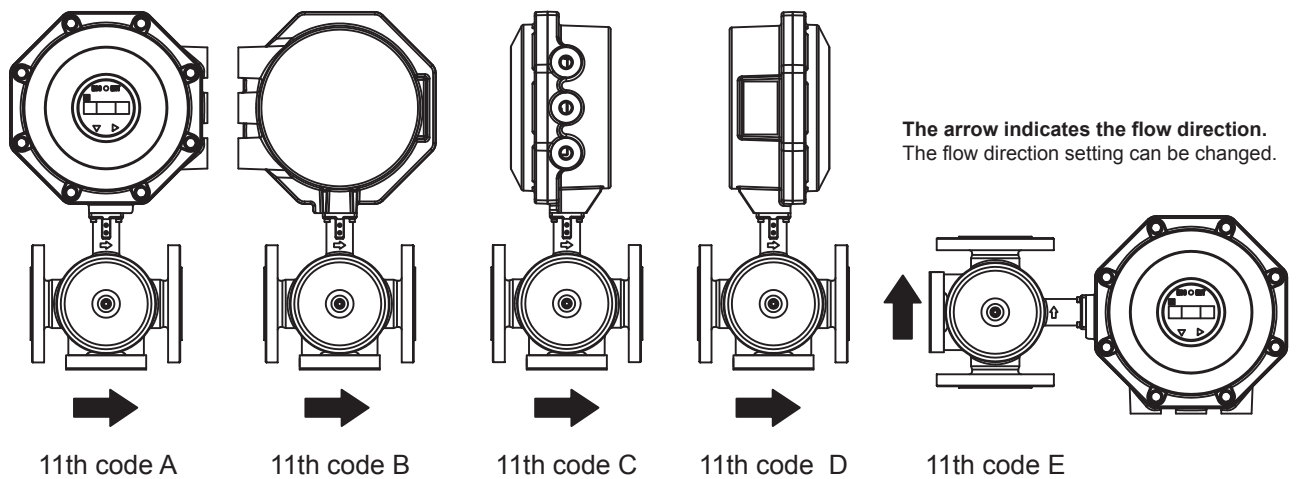

SCOPE OF DELIVERY

1. Flowmeter
2. Magnet bar
3. CD-ROM (contains Japanese/English/Chinese instruction manual, parameter loader software)

Note) Bolts, nuts, and gaskets used for connecting with flange are not provided.

ORDERING INFORMATION

1. Code symbols
2. Tag number, as needed (up to 8 alphanumeric characters)
3. If you order a parameter set version, fill the parameter specification table on the next page and send us.

<Parameter specification table>

Item		Initial value	Set value	Item		Initial value	Set value	
ID No		0000						
Language		English						
Measuring conditions	System unit	Metric		Output conditions	Total output	Total mode	Stop	
	Flow unit	m ³ /h				Total rate	0 m ³	
	Total unit	m ³				Total preset	0 m ³	
	Damping	5.0 s				Pulse width	50.0 ms	
	Low flow cut-off	0.150 m ³ /h				Burnout (total)	Hold	
			Burnout timer			10 s		
Output conditions	Display	1st line	Flow velocity (m/s)			DO1 output type (Note)	Not used	
		1st line decimal point position	****.***			DO1 output action	ON when actuated	
		2nd line	Flow rate (m ³ /h)			DO2 output type (Note)	Not used	
		2nd line decimal point position	****.***			DO2 output action	ON when actuated	
					Operation mode	Standard		
	Analog output	Kind	Flow rate		Communication			
		Range type	Single range			Communication mode	HART	
		Full scale 1	15.000 m ³ /h			Baud rate	9600 bps	
		Full scale 2	0.000 m ³ /h			Parity	Odd	
		Hysteresis	10.00 %			Stop bit	1 bit	
		Burnout (current)	Hold			Station No.	1	
		Burnout timer	10 s					
		Output low limit	-20 %					
Output high limit	120 %							
Rate limit	0.000 m ³ /h							
Rate limit timer	0 s							

Note:

If you select the total rate in the DO1 output type and/or the DO2 output type, set the pulse width and the total rate in the way that both of the condition 1 and the condition 2 indicated below are satisfied.

If you select the automatic 2-range, the bidirectional range, or the bidirectional and automatic 2-range in RANGE TYPE, use the value of FULL SCALE 1 or FULL SCALE 2, whichever is larger, for FULL SCALE in the following equations.

$$\text{Condition 1: } \frac{\text{FULL SCALE [m}^3\text{/s]}}{\text{TOTAL RATE [m}^3\text{]}} \leq 100 \text{ [Hz]}$$

$$\text{Condition 2: } \frac{\text{FULL SCALE [m}^3\text{/s]}}{\text{TOTAL RATE [m}^3\text{]}} \leq \frac{1000}{2 \times \text{PULSE WIDTH [ms]}}$$

[Remarks]

[Reference]

	Unit
Flow velocity	m/s
Flow unit	L/s, L/min, L/h, L/d, kL/d, ML/d m ³ /s, m ³ /min, m ³ /h, m ³ /d, km ³ /d, Mm ³ /d
Total rate	mL, L, m ³ , km ³ , Mm ³

⚠ Caution on Safety

*Before using this product, be sure to read its instruction manual.



Instrumentation & Sensors Planning Dept.
 1, Fuji-machi, Hino-city, Tokyo 191-8502, Japan
<http://www.fujielectric.com>
 Phone: +81-42-514-8930 Fax: +81-42-583-8275
<http://www.fujielectric.com/products/instruments/>