

# Flame Simulator: FS-IR-975





## Legal Notice

The Flame Simulator described in this document is the property of Rosemount.

No part of the hardware, software, or documentation may be reproduced, transmitted, transcribed, stored in a retrieval system, or translated into any language or computer language, in any form or by any means, without prior written permission of Rosemount.

While great efforts have been made to ensure the accuracy and clarity of this document, Rosemount assumes no liability resulting from any omissions in this document or from misuse of the information obtained herein. The information in this document has been carefully checked and is believed to be entirely reliable with all of the necessary information included. Rosemount reserves the right to make changes to any products described herein to improve reliability, function, or design and reserves the right to revise this document and make changes from time to time in content hereof with no obligation to notify any persons of revisions or changes. Rosemount does not assume any liability arising out of the application or any use of any product or circuit described herein; neither does it convey license under its patent rights or the rights of others.

### **WARNING!**

**This manual should be read carefully by all individuals who have or will have responsibility for using, maintaining, or servicing the product.**

**The Simulator is not field repairable due to the meticulous alignment and calibration of the sensors and the respective circuits. Do not attempt to modify or repair the internal circuits or change their settings, as this will impair the system's performance and void the Rosemount product warranty.**

---

## Warranty

- Limited Warranty.** Subject to the limitations contained in Section 10 (Limitation of Remedy and Liability) herein, Seller warrants that (a) the licensed firmware embodied in the Goods will execute the programming instructions provided by Seller; (b) that the Goods manufactured by Seller will be free from defects in materials or workmanship under normal use and care; and (c) Services will be performed by trained personnel using proper equipment and instrumentation for the particular Service provided. The foregoing warranties will apply until the expiration of the applicable warranty period. Sensors and detectors are warranted against defective parts and workmanship for 24 months from the date of purchase and other electronic assemblies for 36 months from the date of purchase. Products purchased by Seller from a third party for resale to Buyer (Resale Products) shall carry only the warranty extended by the original manufacturer. Buyer agrees that Seller has no liability for Resale Products beyond making a reasonable commercial effort to arrange for procurement and shipping of the Resale Products. If Buyer discovers any warranty defects and notifies Seller thereof in writing during the applicable warranty period, Seller shall, at its option, (i) correct any errors that are found by Seller in the firmware or Services; (ii) repair or replace FOB point of manufacture that portion of the Goods found by Seller to be defective; or (iii) refund the purchase price of the defective portion of the Goods/Services. All replacements or repairs necessitated by inadequate maintenance; normal wear and usage; unsuitable power sources or environmental conditions; accident; misuse; improper installation; modification; repair; use of unauthorized replacement parts; storage or handling; or any other cause not the fault of Seller, are not covered by this limited warranty and shall be replaced or repaired at Buyer's sole expense and Seller shall not be obligated to pay any costs or charges incurred by Buyer or any other party except as may be agreed upon in writing in advance by Seller. All costs of dismantling, reinstallation, freight and the time and expenses of Seller's personnel and representatives for site travel and diagnosis under this limited warranty clause shall be borne by Buyer unless accepted in writing by Seller. Goods repaired and parts replaced by Seller during the warranty period shall be in warranty for the remainder of the original warranty period or 90 days, whichever is longer. This limited warranty is the only warranty made by Seller and can be amended only in a writing signed by an authorized representative of Seller. The limited warranty herein ceases to be effective if Buyer fails to operate and use the Goods sold hereunder in a safe and reasonable manner and in accordance with any written instructions from the manufacturers. THE WARRANTIES AND REMEDIES SET FORTH ABOVE ARE EXCLUSIVE. THERE ARE NO REPRESENTATIONS OR WARRANTIES OF ANY KIND, EXPRESSED OR IMPLIED, AS TO MERCHANTABILITY, FITNESS FOR PARTICULAR PURPOSE OR ANY OTHER MATTER WITH RESPECT TO ANY OF THE GOODS OR SERVICES.
- Limitation of Remedy and Liability** SELLER SHALL NOT BE LIABLE FOR DAMAGES CAUSED BY DELAY IN PERFORMANCE. THE REMEDIES OF BUYER SET FORTH IN THE AGREEMENT ARE EXCLUSIVE. IN NO EVENT, REGARDLESS OF THE FORM OF THE CLAIM OR CAUSE OF ACTION (WHETHER BASED IN CONTRACT, INFRINGEMENT, NEGLIGENCE, STRICT LIABILITY, OTHER TORT OR OTHERWISE), SHALL SELLER'S LIABILITY TO BUYER AND/OR BUYER'S CUSTOMERS EXCEED THE PRICE TO BUYER OF THE SPECIFIC GOODS MANUFACTURED OR SERVICES PROVIDED BY SELLER GIVING RISE TO THE CLAIM OR CAUSE OF ACTION. BUYER AGREES THAT IN NO EVENT SHALL SELLER'S LIABILITY TO BUYER AND/OR BUYER'S CUSTOMERS EXTEND TO INCLUDE INCIDENTAL, CONSEQUENTIAL OR PUNITIVE DAMAGES. THE TERM "CONSEQUENTIAL DAMAGES" SHALL INCLUDE, BUT NOT BE LIMITED TO, LOSS OF ANTICIPATED PROFITS, REVENUE OR USE AND COSTS INCURRED INCLUDING WITHOUT LIMITATION FOR CAPITAL, FUEL AND POWER, AND CLAIMS OF BUYER'S CUSTOMERS.

## Release History

Revision	Date	Revision History
A	June 2016	First release
B	August 2017	Updated certification information. Added a blank page between cover page and legal notices. Increased font size for legal notices.

# Contents

<b>Chapter 1</b>	<b>Introduction .....</b>	<b>1</b>
1.1	Model and types .....	1
1.2	Features and benefits .....	1
1.3	Principles of operation .....	2
1.4	Simulator status .....	2
1.5	Product Certification .....	3
1.6	Simulator structure .....	3
1.7	Certification instructions .....	7
1.8	Special conditions for safe use .....	8
<b>Chapter 2</b>	<b>Operation Instructions .....</b>	<b>9</b>
2.1	Ordering information .....	9
2.2	Unpacking the product .....	9
2.3	Operating instructions .....	9
2.4	Detection ranges per detector / flame simulator .....	10
2.5	Charging the battery .....	11
2.6	Replacing the battery .....	12
2.7	Maintenance .....	13
2.8	Troubleshooting .....	13
2.9	Technical specifications .....	13
2.9.1	General specifications .....	13
2.9.2	Electrical Specifications .....	14
2.9.3	Physical specifications .....	14
2.9.4	EMI compatibility .....	15
<b>Chapter 3</b>	<b>Technical Support .....</b>	<b>17</b>



# 1 Introduction

To comply with local standards and jurisdictional authorities, *end-to end* loop testing of fire protection alarm systems, including detectors, should be performed periodically. Many safety authorities and plant managers of high value / high risk assets and facilities insist on quarterly *end-to end* testing of their entire fire protection systems using an external flame simulator.

Rosemount Flame Simulators emit electromagnetic radiation in a unique sequential pattern corresponding to and recognizable as fire by the specific Rosemount 975 Flame Detector model. This allows the detector to be tested under real fire conditions without the associated risk of an open flame. Rosemount Flame Simulators are ATEX certified EExd for use in Zone 1 and Zone 2 hazardous areas and are powered by rechargeable lithium ion batteries. When fully charged, the Flame Simulator will operate for at least 1,000 tests without recharging.

Using an external, portable Rosemount Flame Simulator is the best means to perform a full, functional *end-to-end* test of the detector and the fire protection system without the need to start a real fire (which is not permitted in hazardous areas and can be dangerous in non-hazardous areas). The Rosemount Flame Simulator is the only non-hazardous and safe method to test the Flame Detector's sensors, internal electronics, alarm activation software, cleanliness of the viewing window/lens, wiring integrity, actual relay activation, and proper functionality of any other outputs used (mA, RS-485, HART).

## 1.1 Model and types

The FS-IR-975 Flame Simulator is compatible with the following detector type:

**Table 1-1: Flame simulator compatibility**

Simulator	P/N	Compatible with:
Multi-spectrum Infrared Flame Simulator	FS-IR-975	975MR

## 1.2 Features and benefits

- Used for maintenance and testing of flame detectors.
- Can activate the flame detector from a distance of up to 12 m.
- Includes rechargeable battery.
- Operates at least 1,000 tests before recharging the battery.

## 1.3 Principles of operation

The FS-IR-975 emits IR energy, which is filtered to emit electromagnetic radiation in a sequential pattern, corresponding to and recognizable as a fire by the Rosemount 975 MR Multi-Spectrum Infrared Flame Detectors. The simulator includes a reflector which accumulates the IR energy and directs it towards the detector.

The FS-IR-975 includes a laser diode and a sight in order to point the simulator to the center of the flame detector.

## 1.4 Simulator status

For the first five seconds, the laser defines the simulator status.

### Normal status

At normal, the laser turns on constantly for five seconds before the IR radiation turns on. These five seconds are used to aim the simulator to the center of the detector before the IR radiation turns on. The IR radiation turns on for fifty seconds. After these fifty seconds, the IR radiation turns off, and the simulator cannot be operated for a further twenty seconds (delay between activations).

### Fault status

1. Low battery - The laser flashes three times, stops flashing for a few seconds, flashes three more times, stops flashing, and flashes three more times. The IR radiation will be activated.
2. IR fault - The laser flashes five times, stops flashing for a few seconds, flashes five more times, stops flashing, and flashes five more times. The IR radiation will not be activated.
3. Total failure - The laser does not turn on. The IR radiation will not be activated.



## 1.5 Product Certification

The Flame Simulator is certified to ATEX and IECEx

Ex II 2 G D

Ex db ib op is IIB + H<sub>2</sub> T5 Gb

Ex ib op is tb IIIC T135 °C Db

-20 °C to 50 °C (-4 °F to 122 °F)

This product is suitable for use in hazardous zones 1, 2, 21, and 22 with IIB + H<sub>2</sub> gas group vapor present.

## 1.6 Simulator structure

The Flame Simulator is built from black coated aluminum housing. It includes:

- Reflector
- Electronic chamber
- Battery chamber
- Handle

The electronic chamber includes a PC board with an IR or halogen lamp, which is assembled on the PC board, that emits the light through a sapphire window.

The battery chamber includes a battery pack containing four lithium ion batteries of total 14.8 Vdc and 2.2 AH.

The battery pack can be replaced easily by opening the back cover. This exchange must be done in a safe area, using only a Rosemount battery pack, P/N 00975-9000-0012.

**Figure 1-1: Flame simulator side view**

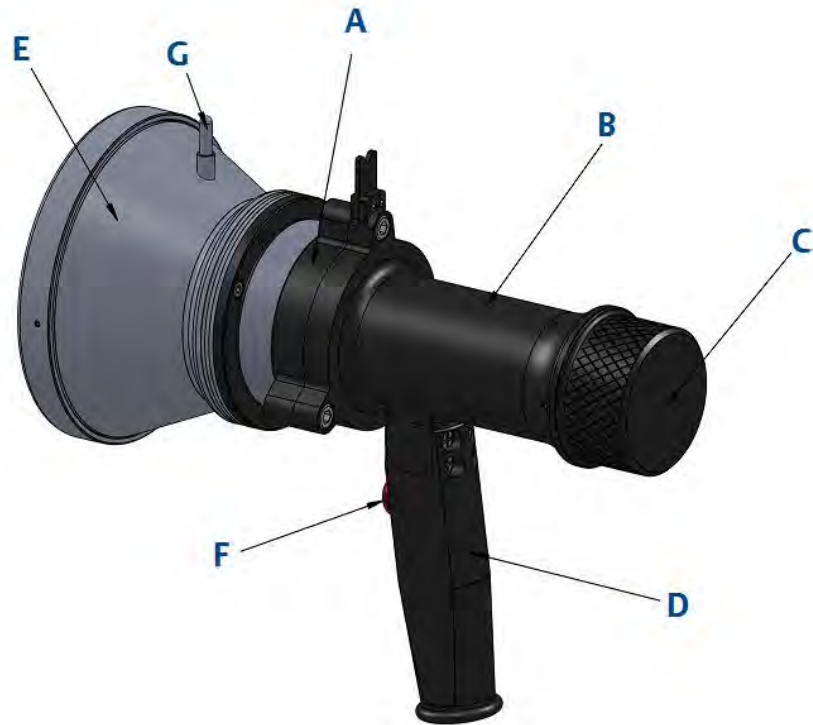

- A. *Electronic chamber*
  - B. *Battery chamber*
  - C. *Battery back cover*
  - D. *Handle*
  - E. *Reflector*
  - F. *Push button*
  - G. *Sight*
-

Figure 1-2: Flame simulator rear view

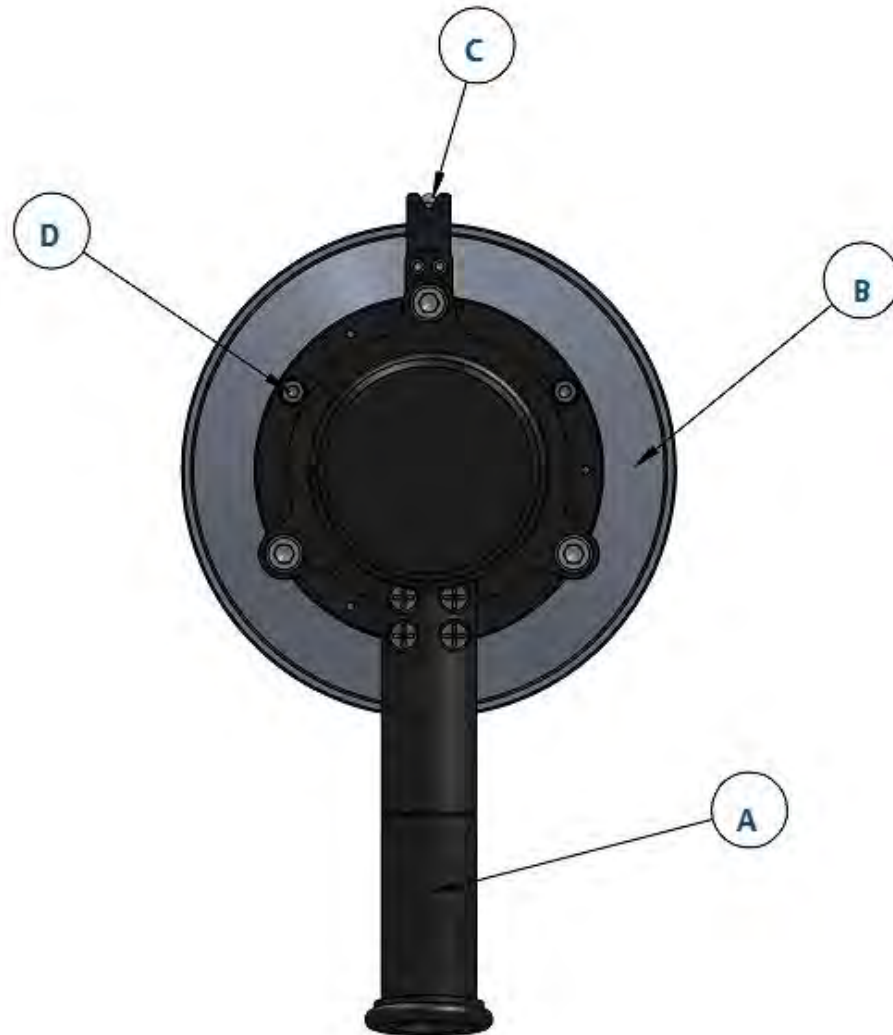

- A. *Handle*
- B. *Reflector*
- C. *Sight*
- D. *Back cover locking screw*

**Figure 1-3: Flame simulator front view**

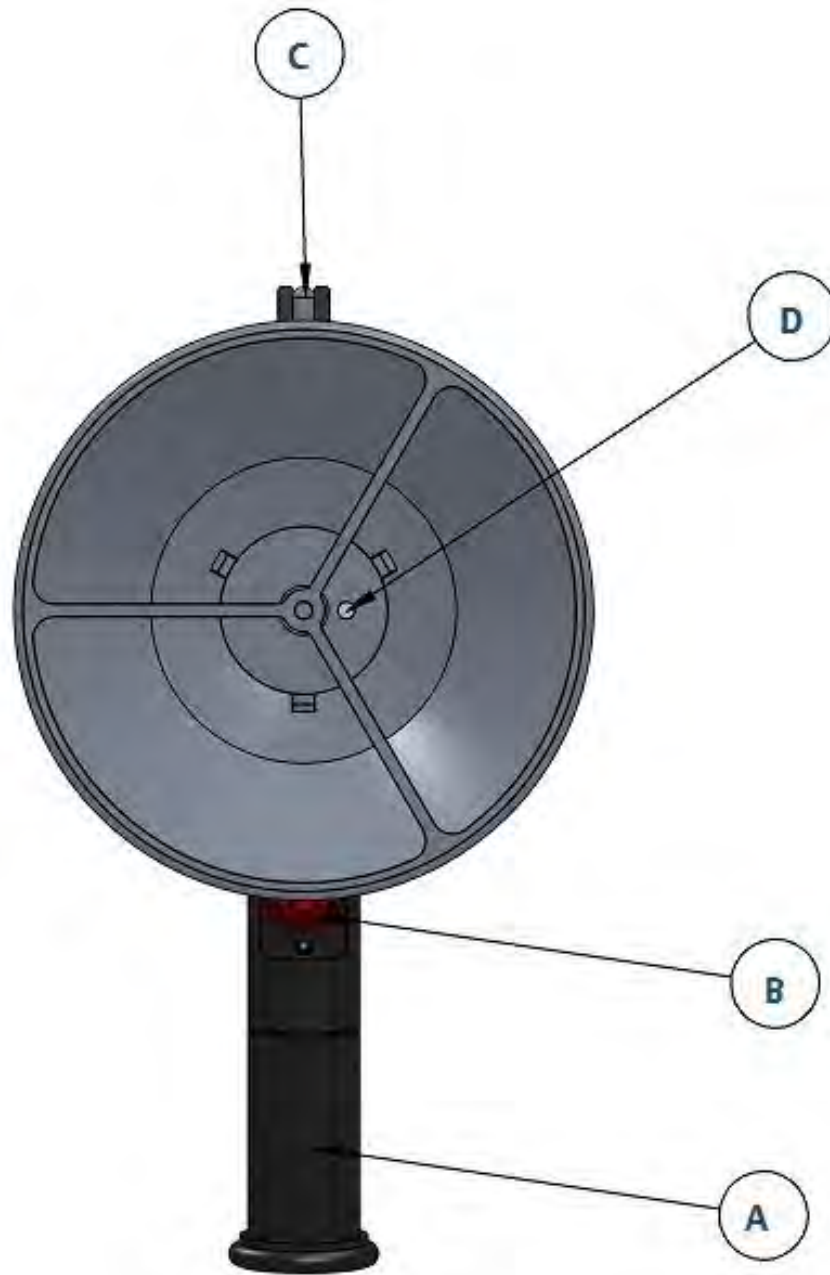

- A. *Handle*
  - B. *Push button*
  - C. *Sight*
  - D. *Laser diode*
-

## 1.7 Certification instructions

### **⚠ WARNING!**

#### **EXPLOSION**

**Do not open the detector, even when isolated, in a flammable atmosphere.**

The equipment marking is defined as follows:

Ex II 2 G D

Ex db ib op is IIB + H<sub>2</sub> T5 Gb

Ex ib op is tb IIIC T135 °C Db

-20 °C to +50 °C (-4 °F to +122 °F)

The equipment may be used with flammable gases and vapors with apparatus groups IIA and IIB + H<sub>2</sub> T5 in the ambient temperature range of -20 °C to +50 °C (-4 °F to +122 °F).

- Inspection and maintenance of this equipment shall be carried out by suitably trained personnel in accordance with the applicable code of practice, e.g., EN 60079-19.
- Repair of this equipment should be performed by suitable trained personnel in accordance with the applicable code of practice, e.g., EN 60079-19.
- The certification of this equipment relies upon the following materials used in its construction:
  - Enclosure: 316L stainless steel
  - Windows: sapphire glass
  - Seals: EPDM
- If the equipment is likely to come into contact with aggressive substances, then it is your responsibility to take suitable precautions that prevent it from being adversely affected, thus ensuring that the type of protection provided by the equipment is not compromised.
  - Aggressive substances: For example, acidic liquids or gases that may attack metal or solvents that may affect polymeric materials.
  - Suitable precautions: For example, regular checks as part of routine inspections or establishing from the material's data sheets that it is resistant to specific chemicals.

## 1.8 Special conditions for safe use

The dimensions of the flameproof joints are other than the relevant minimum or maximum values required by Table 2 of IEC/EN 600791-1: 2007 as detailed below.

Flamepath description	Type of joint	Minimum width "L" (mm)	Maximum gap "ic" (mm)
Joint formed by window against the enclosure	Flanged	10.75	0.02
Enclosure end-cap spigot	Cylindrical	15	0.08

Gaps should not be machined to be any larger than the values of "ic", and width should not be modified to be any smaller than the values of "L" as shown in the table above.

The equipment should only be charged in a safe area. Batteries must be removed from the flameproof enclosure. The charge conditions are as follows:

- Maximum charge voltage: 4.2 V per cell
- Maximum charge current: 2200 mA

The charge voltage and current should not exceed these values.

## 2 Operation Instructions

### 2.1 Ordering information

The P/N of the Flame Simulator kit is FS-IR-975.

The kit is supplied in a carry case that includes:

1. Flame Simulator: FS-IR-975
2. Charger
3. Tool kit
4. Technical manual: 00809-0500-4975

### 2.2 Unpacking the product

Upon receipt of your detector, check and record the following:

- Verify the appropriate purchase order. Record the part number and the serial number of the detectors and source units and the installation date in the appropriate log book.
- Open the container package immediately prior to detector installation and visually inspect the detectors, sources, and accessories.
- Verify that all components required for detector installation are readily available before commencing the installation. In the event that the installation is not completed in a single session, secure and seal detectors and conduits.

### 2.3 Operating instructions

#### Prerequisites

**⚠ WARNING!**

**HAZARDOUS AREAS**

**Do not open the Flame Simulator to charge the batteries or for any other reason in a hazardous area.**

---

**⚠ CAUTION!**

**ALARM ACTIVATION**

The following test simulates a real fire condition and may activate the extinguishing system or other alarms. If this is not desired, disconnect/inhibit them before the test and reconnect after the simulation.

**Procedure**

1. Verify that you are using the correct simulator that fits the tested detector per the following table:

**Table 2-1: Flame Simulator compatibility**

Simulator	Compatible with
FS-IR-975	975MR

2. Verify that you are at the correct distance from the detector according to the type of detector (see [Table 2-2](#)) and the detector sensitivity.
3. Aim the Flame Simulator using the mechanical sight towards the center of the detector. Push the **Activate** button and then use the laser spot for fine adjustment towards the center of the detector.
4. Keep the simulator aimed at the detector for up to fifty seconds until you receive an alarm.
5. Wait twenty seconds before repeating the test.

## 2.4 Detection ranges per detector / flame simulator

**Table 2-2: Detection ranges per detector / flame simulator**

Model	Detector types	Detector sensitivity settings	Testing distance
FS-IR-975	975MR	50 ft. (15 m)	6.6 ft. (2 m)
		100 ft. (30 m)	19.6 ft. (6 m)
		150 ft. (45 m)	29.5 ft. (9 m)
		215 ft. (65.5 m)	39.3 ft. (12 m)

**Notes**

- The minimum distance from the detector is 30 in. (75 cm).
- At extreme temperatures, there is a 15% reduction in the testing range.



**Important**

Keep the Flame Simulator in a safe place when not in use.

---

## 2.5 Charging the battery

The Flame Simulator uses lithium ion batteries as a rechargeable power source. When the batteries are fully charged, the simulator operates at least 1,000 times without recharging. When the voltage from the batteries is lower than the required operational level, the simulator will not operate.

To charge the battery:

**Procedure**

1. Place the Flame Simulator on a table in a safe area not exceeding 40 °C(104 °F).
2. Release the locking screw (Item D, [Figure 1-2](#)).
3. Unscrew the battery back cover (Item C, [Figure 1-1](#)) counter-clockwise.
4. Unscrew the locking disc clockwise (Item C, [Figure 2-1](#)).
5. Pull out the battery from the Flame Simulator.
6. Connect the battery to the charger. Verify that the charger is the one supplied with the Flame Simulator model FRIWO MPP15 with max. charging voltage 16.8 V (4.2 V x 4) with max. current of 700 mA.
7. Charge for a maximum of two to three hours, until the green LED on the charger turns on.
8. Disconnect the charger.
9. Insert the battery into the Flame Simulator.
10. Screw in the locking disc (Item C, [Figure 2-1](#)).
11. Screw in the back cover (Item C, [Figure 1-1](#)).
12. Lock the back cover with the locking screw (Item D, [Figure 1-2](#)).

## 2.6 Replacing the battery

1. Place the Flame Simulator on a table in a safe area not exceeding 104 °F (40 °C).
2. Release the locking screw (Item D, [Figure 1-2](#)).
3. Unscrew the battery back cover (Item C, [Figure 1-1](#)).
4. Unscrew the locking disc clockwise (Item C, [Figure 2-1](#)).
5. Pull out the battery from the Flame Simulator.
6. Insert the new battery pack into the simulator housing. Use only Rosemount battery pack, P/N 00975-9000-0012.
7. Screw in the locking disc (Item C, [Figure 2-1](#)).
8. Screw in the back cover (Item C, [Figure 1-1](#)).
9. Lock the back cover with the locking screw (Item D, [Figure 1-2](#)).

---

**Figure 2-1: Flame Simulator battery replacement**



- A. Simulator
  - B. Battery pack
  - C. Locking disc
  - D. Back cover
-

## 2.7 Maintenance

- Ensure the Flame Simulator is charged before operation.
- Ensure the reflector and the window are clean.
- Before replacing the battery, ensure that you have a Rosemount battery pack, P/N 00975-9000-0012.
- When the simulator is not in use, recharge at least every six months.

### **⚠ CAUTION!**

#### **EQUIPMENT DAMAGE**

**Use only Rosemount replacement battery pack, P/N 00975-9000-0012.**

## 2.8 Troubleshooting

**Table 2-3: Troubleshooting**

Model	Problem	Solution
FS-IR-975	Laser flashes 3 times.	1. Recharge the battery.
	Laser flashes 5 times.	1. Operate the Flame Simulator again. 2. Send the Flame Simulator for repair.
	The laser does not turn on.	1. Recharge the battery. 2. Replace the battery. 3. Send the Flame Simulator for repair.
	The Flame Simulator seems to work properly but does not activate the Flame Detector.	1. Verify that you are at the correct distance. 2. Verify that the Flame Detector is at the correct sensitivity. 3. Verify that the Flame Detector is operating. 4. Verify that the Flame Detector is clean.

## 2.9 Technical specifications

### 2.9.1 General specifications

Temperature range: -20 °C to +50 °C (-4 °F to +122 °F).

Vibration protection: 1 g (10 - 50 Hz)

## 2.9.2 Electrical Specifications

Power: 14.8 V (4 x 3.7 V rechargeable lithium ion battery)

Max current: 0.2 A

Battery capacity: 2.2 AH

Charging time: 2 hours at 2 A

## 2.9.3 Physical specifications

Dimensions: 9 x 7.3 x 5.35 in. (230 x 185 x 136 mm)

Weight: 5.5 lb. (2.5 kg)

Enclosure: aluminum, heavy duty copper free, black zinc coating

Explosion proof enclosure:

ATEX and IECEx

Ex II 2 G D

Ex db ib op is IIB + H<sub>2</sub> T5 Gb

Ex ib op is tb IIIC T135 °C Db

-20 °C to +50 °C (-4 °F to +122 °F)

Water and dust tight: IP65

## 2.9.4 EMI compatibility

**Table 2-4: Immunity tests**

Title	Basic standard	Level to be tested
Electrostatic discharge (ESD)	IEC 61000-4-2	6 kV / 8 kV contact/air
Radiated electromagnetic field	IEC 61000-4-3	20 V/m (80 MHz to 1 GHz) 10 V/m (1.4 GHz to 2 GHz) 3 V/m (2.0 GHz to 2.7 GHz)
Conducted disturbances	IEC 61000-4-6	10 Vrms (150 kHz to 80 MHz)
Immunity to main supply voltage variations	MIL-STD-1275B	

**Table 2-5: Emission test**

Title	Basic standard	Level to be tested	Class
Radiated emission	IEC 61000-6-3	40 dbuv/m (30 MHz - 230 MHz), 47 dbuv/m (230 MHz - 1 GHz)	Like Class B of EN 55022



# 3 Technical Support

For all technical assistance or support contact:

Emerson Automation Solutions

6021 Innovation Boulevard

Shakopee, MN 55379-9795

USA

T +1 866 347 3427

F +952 949 7001

[SAFETY.CSC@Emerson.com](mailto:SAFETY.CSC@Emerson.com)

**GLOBAL HEADQUARTERS**

Rosemount  
6021 Innovation Blvd.  
Shakopee, MN 55379

 Toll Free + 866 347 3427

 F +1 952 949 7001

 [safety.csc@emerson.com](mailto:safety.csc@emerson.com)

[www.Emerson.com/FlameGasDetection](http://www.Emerson.com/FlameGasDetection)

**EUROPE**

Emerson Automation Solutions  
Neuhofstrasse 19a PO Box 1046  
CH-6340 Baar  
Switzerland

 T +41 (0) 41 768 6111

 F +41 (0) 41 768 6300

[safety.csc@emerson.com](mailto:safety.csc@emerson.com)

[www.Emerson.com/FlameGasDetection](http://www.Emerson.com/FlameGasDetection)

**MIDDLE EAST AND AFRICA**

Emerson Automation Solutions  
Emerson FZE  
Jebel Ali Free Zone  
Dubai, United Arab Emirates, P.O. Box 17033

 T +971 4 811 8100

 F +971 4 886 5465

[safety.csc@emerson.com](mailto:safety.csc@emerson.com)

[www.Emerson.com/FlameGasDetection](http://www.Emerson.com/FlameGasDetection)

**ASIA-PACIFIC**

Emerson Automation Solutions  
Asia Pacific Private Limited  
1 Pandan Crescent  
Singapore 128461  
Republic of Singapore

 T +65 6 777 8211

 F +65 6 777 0947

[safety.csc@emerson.com](mailto:safety.csc@emerson.com)

[www.Emerson.com/FlameGasDetection](http://www.Emerson.com/FlameGasDetection)

 [Linkedin.com/company/Emerson-Automation-Solutions](https://www.linkedin.com/company/Emerson-Automation-Solutions)

 [twitter.com/rosemount\\_news](https://twitter.com/rosemount_news)

 [Facebook.com/Rosemount](https://www.facebook.com/Rosemount)

 [youtube.com/RosemountMeasurement](https://www.youtube.com/RosemountMeasurement)

 [google.com/+RosemountMeasurement](https://plus.google.com/+RosemountMeasurement)

 [AnalyticExpert.com](http://AnalyticExpert.com)

©2017 Emerson. All rights reserved.

The Emerson logo is a trademark and service mark of Emerson Electric Co. Rosemount is a mark of one of the Emerson family of companies. All other marks are the property of their respective owners.