

APPLICATION NOTE	FECA-AN-181
PID Control with Pressure Transducer Wiring and Function Code Settings	

Inverter type	FRENIC-Ace series
Software version	All versions
Required options	None
Related documentation	-
Author	Jared Orlicki
Date	10/24/2017
Revision	-

Introduction:

This application note details the wiring and configuration of the **FRENIC-Ace** drive for PID control with a 4-20mA pressure transducer feedback signal.

Wiring:

The pressure transducer is to be connected to the drive as follows:

- 1) Connect drive terminal **PLC** (24VDC) to the sensor's **red** lead or terminal **1 (+)**
- 2) Connect drive terminal **C1** (+) to the sensor's **black** lead or terminal **2 (-)**
- 3) Connect a wire jumper between drive terminals **11** and **CM**

Refer to FIGURE 1 below:

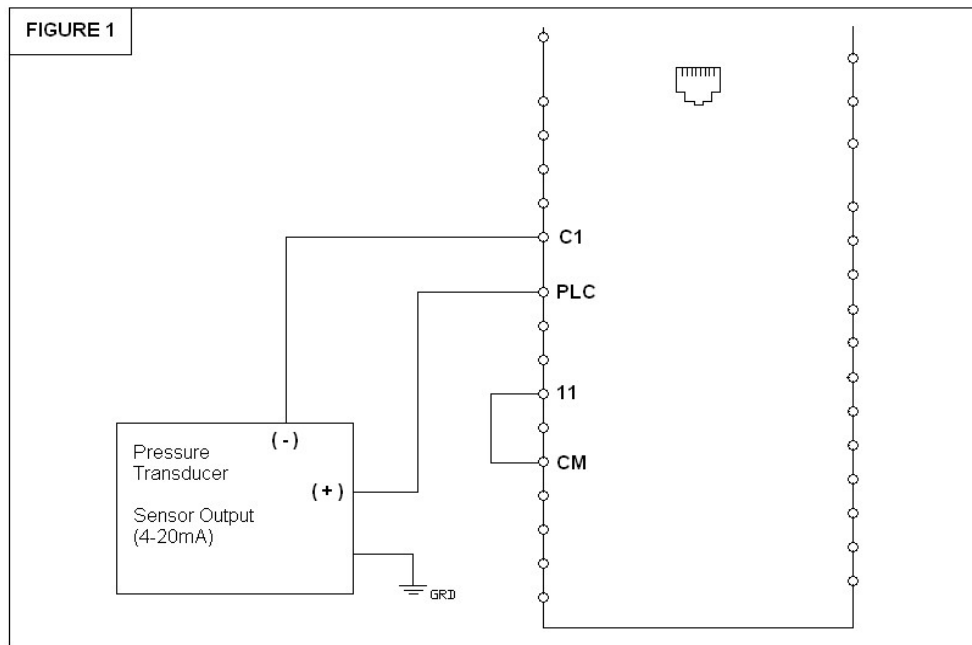

Function Codes

The following table displays the parameters that need to be set for the drive to operate under PID control utilizing the keypad to set the command (target) value and a 4-20mA feedback signal. Consult the FRENIC-Ace Instruction Manual for additional information on the configuration of these function codes.

Code	Setting	Description
J01	1 - for normal operation (typical for pump application) 2 - for inverse operation (typical for cooling application)	PID Control Mode
J02	0 – keypad process command	PID Process Command (how to set target value)
J03	3 (*)	P – Proportional Gain
J04	1 second (*)	I – Integral Time
C64	2 – % (percent) (**) 46 – psi (pounds/square inch) (**) 61 – °C (degrees Celsius) (**) 62 – °F (degrees Fahrenheit) (**)	Display Units (**)
C65	Highest value of sensor range	Maximum Scale
C66	Lowest value of sensor range	Minimum Scale
E43	10 – for PID process command (SV) 12 – for PID feedback (PV) 14 – for PID output (MV)	LED Monitor (Item Selection)
E62	5 – PID feedback value	Analog Input Terminal C1 Function Selection

(*)Note: These are initial settings and will need to be adjusted to provide optimum performance per the actual system characteristics and desired response. Changes should be made gradually as you will want to have stable operation with the maximum regulation; excessive settings could result in unstable operation.

()Note:** The “display units” setting is only valid for the multi-function type keypad. Consult the Ace Instruction Manual or User’s Manual for a full listing of available display unit settings.

Entering the Set value

The set value (SV) is the target value that the PID loop will attempt to maintain. The setting of function code **J02** determines how this value will be entered. It can be entered by utilizing the **UP and DOWN** arrows on the keypad when **J02** is set to a **0** (default setting).

Refer to the **FRENIC-Ace Instruction Manual (INR-SI47-1733f-E)** for additional information.