

Technical Information

Micropilot FMR60

Free space radar

Level measurement in liquids

Application

- Continuous, non-contact level measurement of liquids, pastes and sludges
- PTFE drip-off antenna
- Maximum measuring range: 50 m (164 ft)
- Temperature: -40 to +130 °C (-40 to +266 °F)
- Pressure: -1 to +16 bar (-14.5 to +232 psi)
- Accuracy: ± 1 mm (0.04 in)
- Linearity protocol (3-point, 5-point)



Your benefits

- Innovative drip-off antenna made of PTFE
- Reliable measurement thanks to improved focusing and small beam angle, particularly in vessels with many internal fittings
- Safety by design - ensures highest safety
- Easy, guided commissioning with intuitive user interface
- *Bluetooth*® wireless technology for commissioning, operation and maintenance via free iOS / Android app SmartBlue
- Maximum reliability thanks to multi-echo tracking
- HistoROM configuration memory makes for easier commissioning, maintenance and diagnostics
- SIL2 as per IEC 61508, SIL3 for homogeneous or diverse redundancy
- Easy proof testing for SIL and WHG
- RFID TAG - easy identification of measuring points for improved data access
- Heartbeat Technology





Table of contents

Important document information	4	Climate class	31
Safety symbols	4	Altitude according to IEC61010-1 Ed.3	31
Electrical symbols	4	Degree of protection	31
Symbols for certain types of information	4	Vibration resistance	31
Symbols in graphics	4	Electromagnetic compatibility (EMC)	31
Symbols at the device	5		
Terms and abbreviations	6	Process	32
Registered trademarks	7	Process temperature, process pressure	32
Function and system design	8	Dielectric constant	33
Measuring principle	8	Minimum level in case of small dielectric constants	33
Input	9	Mechanical construction	34
Measured variable	9	Dimensions	34
Measuring range	9	Weight	37
Operating frequency	10	Materials: GT19 housing (plastic)	38
Transmission power	10	Materials: GT20 housing (die-cast aluminum, powder-coated)	39
Output	11	Materials: antenna and process connection	40
Output signal	11	Materials: Weather protection cover	41
Signal on alarm	12	Operability	42
Linearization	12	Operating concept	42
Galvanic isolation	12	Local operation	43
Protocol-specific data	12	Operation with remote display and operating module FHX50	43
Power supply	14	Operation via Bluetooth® wireless technology	44
Terminal assignment	14	Remote operation	45
Device plug connectors	18	SupplyCare inventory management software	46
Supply voltage	19	Certificates and approvals	49
Power consumption	20	CE mark	49
Current consumption	20	RoHS	49
Power supply failure	20	RCM-Tick marking	49
Potential equalization	20	Ex approval	49
Cable entries	21	Dual seal according to ANSI/ISA 12.27.01	49
Cable specification	21	Functional safety	49
Overvoltage protection	21	WHG	49
Performance characteristics	22	Pressure equipment with allowable pressure ≤ 200 bar (2 900 psi)	49
Reference operating conditions	22	Radio standard EN 302729	50
Reference accuracy	22	Radio standard EN 302372	51
Measured value resolution	22	FCC	51
Response time	22	Industry Canada	51
Influence of ambient temperature	23	CRN approval (Canadian pressure equipment directive)	51
Influence of gas phase	23	Test, certificate	53
Installation	24	Hard-copy product documentation	53
Installation conditions	24	Other standards and guidelines	54
Installation: Drip-off antenna, PTFE 50 mm / 2"	28	Ordering information	55
Container with heat insulation	29	Ordering information	55
Environment	30	3-point linearity protocol	56
Ambient temperature range	30	5-point linearity protocol	57
Ambient temperature limits	30	Customer-specific configuration	58
Storage temperature	31	Tagging (TAG)	58
		Services	58





Application Packages	59
Heartbeat Diagnostics	59
Heartbeat Verification	60
Heartbeat Monitoring	61
Accessories	62
Device-specific accessories	62
Communication-specific accessories	67
Service-specific accessories	68
System components	68
Supplementary documentation	69
Standard documentation	69
Safety Instructions (XA)	69

Important document information









Safety symbols

Symbol	Meaning
	DANGER! This symbol alerts you to a dangerous situation. Failure to avoid this situation will result in serious or fatal injury.
	WARNING! This symbol alerts you to a dangerous situation. Failure to avoid this situation can result in serious or fatal injury.
	CAUTION! This symbol alerts you to a dangerous situation. Failure to avoid this situation can result in minor or medium injury.
	NOTE! This symbol contains information on procedures and other facts which do not result in personal injury.

Electrical symbols



Symbol	Meaning
	Direct current
	Alternating current
	Direct current and alternating current
	Ground connection A grounded terminal which, as far as the operator is concerned, is grounded via a grounding system.
	Protective Earth (PE) A terminal which must be connected to ground prior to establishing any other connections. The ground terminals are situated inside and outside the device: <ul style="list-style-type: none"> ▪ Inner ground terminal: Connects the protective earth to the mains supply. ▪ Outer ground terminal: Connects the device to the plant grounding system.

Symbols for certain types of information

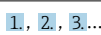

Symbol	Meaning
	Permitted Procedures, processes or actions that are permitted.
	Preferred Procedures, processes or actions that are preferred.
	Forbidden Procedures, processes or actions that are forbidden.
	Tip Indicates additional information.
	Reference to documentation.
	Reference to page.
	Reference to graphic.
	Visual inspection.

Symbols in graphics

Symbol	Meaning
1, 2, 3 ...	Item numbers
	Series of steps
A, B, C, ...	Views

Symbol	Meaning
A-A, B-B, C-C, ...	Sections
	Hazardous area Indicates a hazardous area.
	Safe area (non-hazardous area) Indicates the non-hazardous area.

Symbols at the device

Symbol	Meaning
	Safety instructions Observe the safety instructions contained in the associated Operating Instructions.
	Temperature resistance of the connection cables Specifies the minimum value of the temperature resistance of the connection cables.

Terms and abbreviations

Term/abbreviation	Explanation
BA	Document type "Operating Instructions"
KA	Document type "Brief Operating Instructions"
TI	Document type "Technical Information"
SD	Document type "Special Documentation"
XA	Document type "Safety Instructions"
PN	Nominal pressure
MWP	Maximum Working Pressure The MWP can also be found on the nameplate.
ToF	Time of Flight
FieldCare	Scalable software tool for device configuration and integrated plant asset management solutions
DeviceCare	Universal configuration software for Endress+Hauser HART, PROFIBUS, FOUNDATION Fieldbus and Ethernet field devices
DTM	Device Type Manager
DD	Device Description for HART communication protocol
ϵ_r (DC value)	Relative dielectric constant
Operating tool	The term "operating tool" is used in place of the following operating software: <ul style="list-style-type: none"> ▪ FieldCare / DeviceCare, for operation via HART communication and PC ▪ SmartBlue (app), for operation using an Android or iOS smartphone or tablet.
BD	Blocking Distance; no signals are analyzed within the BD.
PLC	Programmable Logic Controller
CDI	Common Data Interface
PFS	Pulse Frequency Status (Switching output)

Registered trademarks

HART®

Registered trademark of the HART Communication Foundation, Austin, USA

Bluetooth®

The Bluetooth® word mark and logos are registered trademarks owned by the Bluetooth SIG, Inc. and any use of such marks by Endress+Hauser is under license. Other trademarks and trade names are those of their respective owners.

Apple®

Apple, the Apple logo, iPhone, and iPod touch are trademarks of Apple Inc., registered in the U.S. and other countries. App Store is a service mark of Apple Inc.

Android®

Android, Google Play and the Google Play logo are trademarks of Google Inc.

KALREZ®, VITON®

Registered trademark of DuPont Performance Elastomers L.L.C., Wilmington, USA

TEFLON®

Registered trademark of E.I. DuPont de Nemours & Co., Wilmington, USA

Function and system design

Measuring principle

The Micropilot is a "downward-looking" measuring system, operating based on the frequency modulated continuous wave method (FMCW). The antenna emits an electromagnetic wave at a continuously varying frequency. This wave is reflected by the product and received again by the antenna.

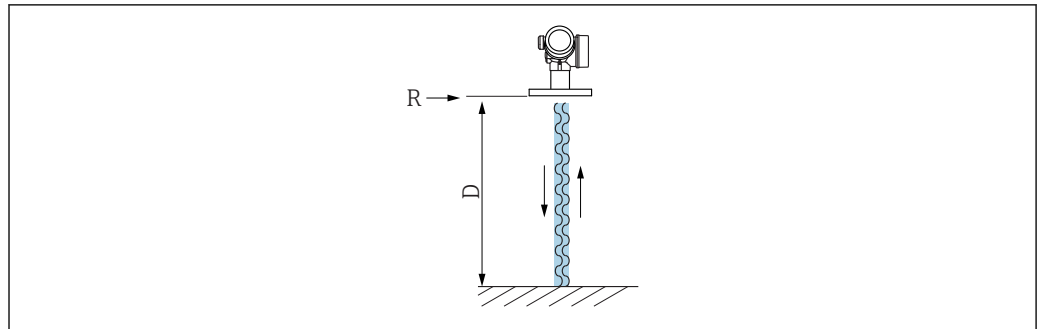

A0032017

1 FMCW principle: transmission and reflection of the continuous wave

R Reference point of measurement

D Distance between reference point and product surface

The frequency of this wave is modulated in the form of a sawtooth signal between two limit frequencies f_1 and f_2 :

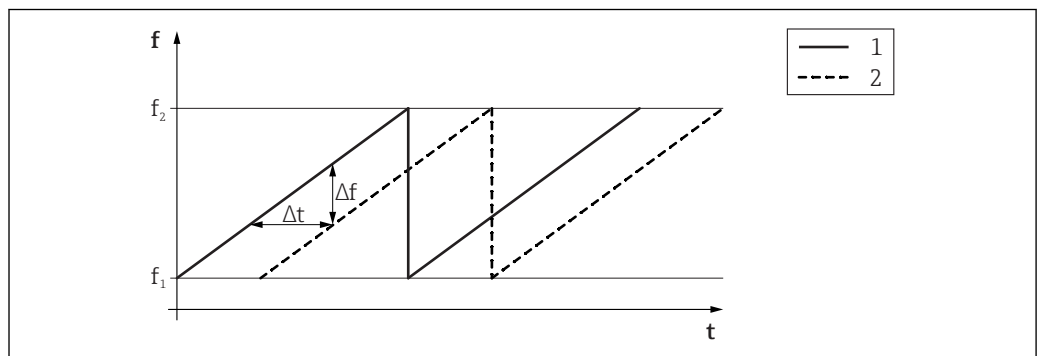

A0023771

2 FMCW principle: result of frequency modulation

1 Transmitted signal

2 Received signal

This results in the following difference frequency at any time between the transmitted signal and the received signal:

$$\Delta f = k \Delta t$$

where Δt is the run time and k is the specified increase in frequency modulation.

Δt is given by the distance D between the reference point R and the product surface:

$$D = (c \Delta t) / 2$$

where c is the speed of propagation of the wave.

In summary, D can be calculated from the measured difference frequency Δf . D is then used to determine the content of the tank or silo.

Input

Measured variable The measured variable is the distance between the reference point and the product surface. The level is calculated based on "E", the empty distance entered. Optionally, the level can be converted to other variables (volume, mass) by linearization (32 value pairs).

Measuring range

Maximum measuring range

Device	Antenna ¹⁾	Maximum measuring range
FMR60	GA: Drip-off, PTFE 50 mm / 2"	50 m (164 ft)

1) Feature 070 in the product structure

Usable measuring range

The usable measuring range depends on the antenna size, the medium's reflective properties, the installation position and any possible interference reflections.

The following tables describe the groups of media as well as the achievable measuring range as a function of application and media group. If the dielectric constant of a medium is unknown, it is recommended to assume media group B to ensure a reliable measurement.

Media groups

Media group	DC (ϵ_r)	Example
A0	1.2 to 1.4	Butane, liquid nitrogen, liquefied hydrogen
A	1.4 to 1.9	non-conducting liquids, e.g. liquefied gas ¹⁾
B	1.9 to 4	non-conducting liquids, e.g. benzene, oil, toluene, ...
C	4 to 10	e.g. concentrated acids, organic solvents, esters, aniline, alcohol, acetone, ...
D	> 10	conducting liquids, e.g. aqueous solutions, dilute acids and alkalis

1) NH_3 falls into medium group A.



For dielectric constants (DC values) of many media commonly used in various industries refer to:

- the Endress+Hauser DC manual (CP01076F)
- the Endress+Hauser "DC Values App" (available for Android and iOS)

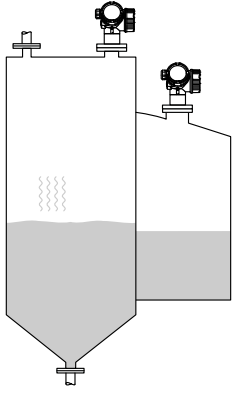
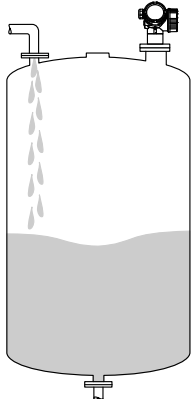
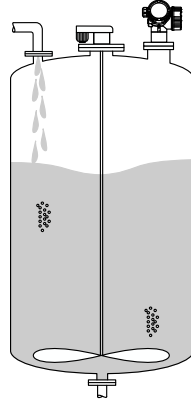
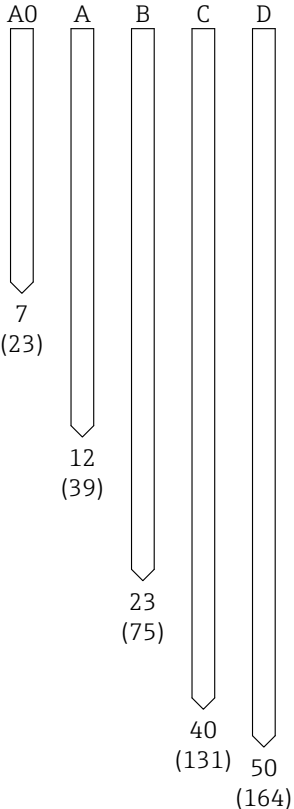
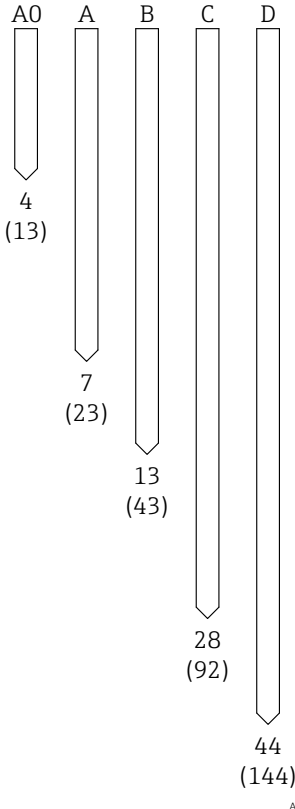
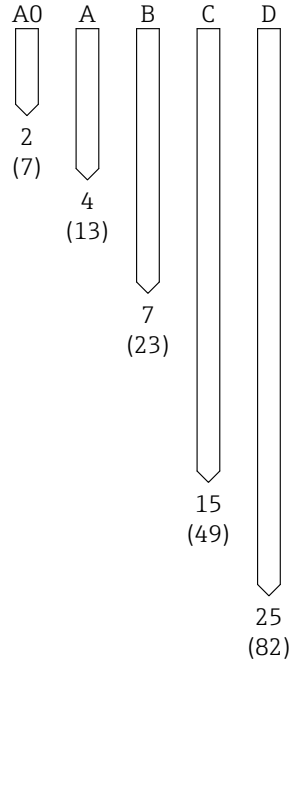
FMR60		
Storage tank	Buffer tank	Process tank with agitator
 <p>A0034565</p> <p>Calm product surface (e.g. intermittent filling, filling from bottom, immersion tubes)</p>	 <p>A0034566</p> <p>Moving surfaces (e.g. continuous filling, from above, mixing jets)</p>	 <p>A0034567</p> <p>Turbulent surface (e.g. filling from above, agitators, baffles)</p>
 <p>A0034574</p>	 <p>A0034579</p>	 <p>A0034584</p>
Measuring range [m (ft)]		

Operating frequency

Approx. 80 GHz

Up to 8 devices can be installed in the same tank without interfering with each other.

Transmission power

- Peak power: 6.3 mW
- Average output power: 63 µW

Output

Output signal

HART

Signal coding	FSK ± 0.5 mA over current signal
Data transmission rate	1 200 Bit/s
Galvanic isolation	Yes

Bluetooth® wireless technology

Device version	Ordering feature 610 "Accessory mounted", option NF "Bluetooth"
Operation / configuration	By the <i>SmartBlue</i> app.
Range under reference conditions	> 10 m (33 ft)
Encryption	Encrypted communication and password encryption prevent incorrect operation by unauthorized persons.

Switch output

 For HART devices, the switch output is available as an option. See product structure, feature 20: "Power Supply, Output", option B: "2-wire; 4-20mA HART, switch output"

Switch output	
Function	Open collector switching output
Switching behavior	Binary (conductive or non-conductive), switches when the programmable switch point is reached
Failure mode	non-conductive
Electrical connection values	$U = 16$ to 35 V _{DC} , $I = 0$ to 40 mA
Internal resistance	$R_i < 880 \Omega$ The voltage drop at this internal resistance has to be taken into account on planning the configuration. For example, the resulting voltage at a connected relay must be sufficient to switch the relay.
Insulation voltage	floating, Insulation voltage $1\,350$ V _{DC} to power supply and 500 V _{AC} to ground
Switch point	freely programmable, separately for switch-on and switch-off point
Switching delay	freely programmable from 0 to 100 s, separately for switch-on and switch-off point
Number of switching cycles	corresponds to the measuring cycle
Signal source device variables	<ul style="list-style-type: none"> ■ Level linearized ■ Distance ■ Terminal voltage ■ Electronic temperature ■ Relative echo amplitude ■ Diagnostic values, Advanced diagnostics
Number of switching cycles	unlimited

Signal on alarm

Depending on the interface, failure information is displayed as follows:

- Current output (for HART devices)
 - Failsafe mode selectable (in accordance with NAMUR Recommendation NE 43):
 - Minimum alarm: 3.6 mA
 - Maximum alarm (= factory setting): 22 mA
 - Failsafe mode with user-selectable value: 3.59 to 22.5 mA
- Local display
 - Status signal (in accordance with NAMUR Recommendation NE 107)
 - Plain text display
- Operating tool via HART communication or service interface (CDI)
 - Status signal (in accordance with NAMUR Recommendation NE 107)
 - Plain text display

Linearization

The linearization function of the device allows the conversion of the measured value into any unit of length or volume. Linearization tables for calculating the volume in cylindrical tanks are pre-programmed. Other linearization tables of up to 32 value pairs can be entered manually or semi-automatically.

Galvanic isolation

All circuits for the outputs are galvanically isolated from each other.

Protocol-specific data**HART**

Manufacturer ID	17 (0x11)
Device type ID	0x112B
HART specification	7.0
Device description files (DTM, DD)	Information and files under: <ul style="list-style-type: none"> ▪ www.endress.com ▪ www.fieldcommgroup.org
HART load	min. 250 Ω
HART device variables	<p>The measured values can be freely assigned to the device variables.</p> <p>Measured values for PV (primary variable)</p> <ul style="list-style-type: none"> ▪ Level linearized ▪ Distance ▪ Electronic temperature ▪ Relative echo amplitude ▪ Area of incoupling ▪ Analog output adv. diagnostics 1 ▪ Analog output adv. diagnostics 2 <p>Measured values for SV, TV, FV (second, third and fourth variable)</p> <ul style="list-style-type: none"> ▪ Level linearized ▪ Distance ▪ Electronic temperature ▪ Terminal voltage ▪ Relative echo amplitude ▪ Absolute echo amplitude ▪ Area of incoupling ▪ Analog output adv. diagnostics 1 ▪ Analog output adv. diagnostics 2
Supported functions	<ul style="list-style-type: none"> ▪ Burst mode ▪ Additional transmitter status

Wireless HART data

Minimum start-up voltage	16 V
Start-up current	3.6 mA
Start-up time	65 s
Minimum operating voltage	14.0 V

Multidrop current	4.0 mA
Set-up time	15 s

Power supply

Terminal assignment

Terminal assignment 2-wire: 4-20 mA HART

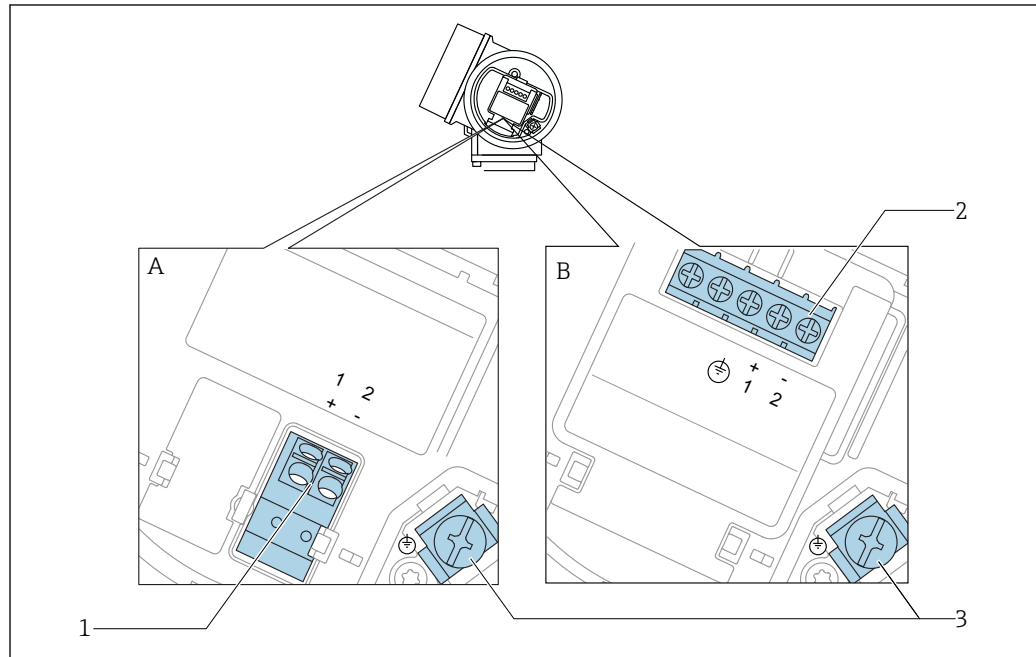

A0036498

3 Terminal assignment 2-wire: 4-20 mA HART

- A Without integrated overvoltage protection
 B With integrated overvoltage protection
 1 Connection 4-20 mA HART passive: terminals 1 and 2, without integrated overvoltage protection
 2 Connection 4-20 mA HART passive: terminals 1 and 2, with integrated overvoltage protection
 3 Terminal for cable screen

Block diagram 2-wire: 4-20 mA HART

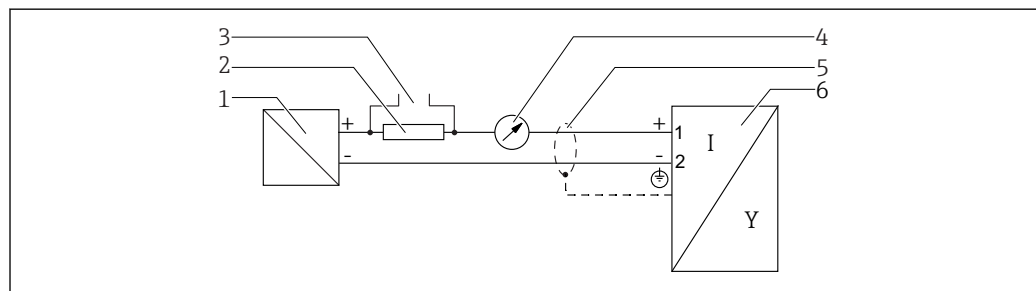

A0036499

4 Block diagram 2-wire: 4-20 mA HART

- 1 Active barrier with power supply (e.g. RN221N); observe terminal voltage
 2 HART communication resistor ($\geq 250 \Omega$); observe maximum load
 3 Connection for Commubox FXA195 or FieldXpert SFX350/SFX370 (via VIATOR Bluetooth modem)
 4 Analog display device; observe maximum load
 5 Cable screen; observe cable specification
 6 Measuring device

Terminal assignment 2-wire: 4-20 mA HART, switch output

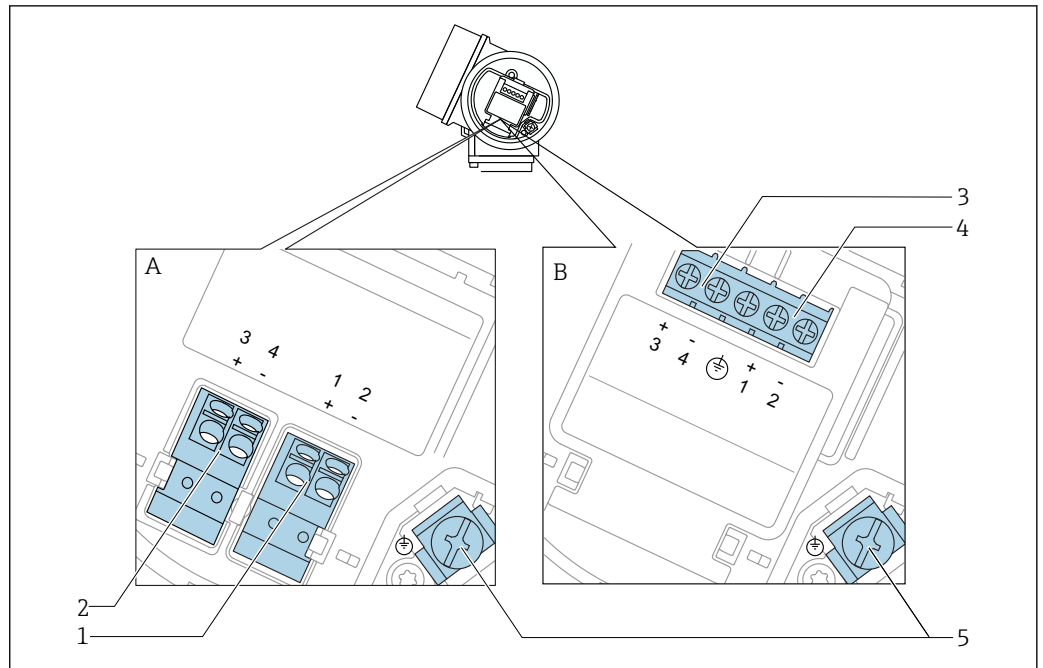

5 Terminal assignment 2-wire: 4-20 mA HART, switch output

A Without integrated overvoltage protection

B With integrated overvoltage protection

1 Connection 4-20 mA HART passive: terminals 1 and 2, without integrated overvoltage protection

2 Connection switch output (Open Collector): terminals 3 and 4, without integrated overvoltage protection

3 Connection switch output (Open Collector): terminals 3 and 4, with integrated overvoltage protection

4 Connection 4-20 mA HART passive: terminals 1 and 2, with integrated overvoltage protection

5 Terminal for cable screen

Block diagram 2-wire: 4-20 mA HART, switch output

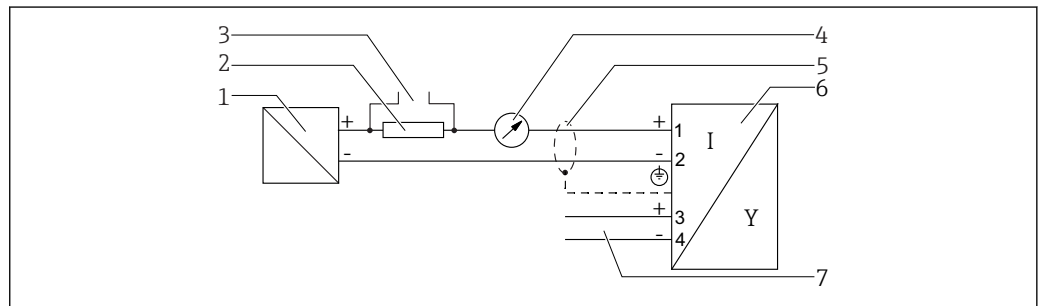

6 Block diagram 2-wire: 4-20 mA HART, switch output

1 Active barrier with power supply (e.g. RN221N); observe terminal voltage

2 HART communication resistor ($\geq 250 \Omega$); observe maximum load

3 Connection for Commubox FXA195 or FieldXpert SFX350/SFX370 (via VIATOR Bluetooth modem)

4 Analog display device; observe maximum load

5 Cable screen; observe cable specification

6 Measuring device

7 Switch output (Open Collector)

Terminal assignment 2-wire: 4-20 mA HART, 4-20 mA

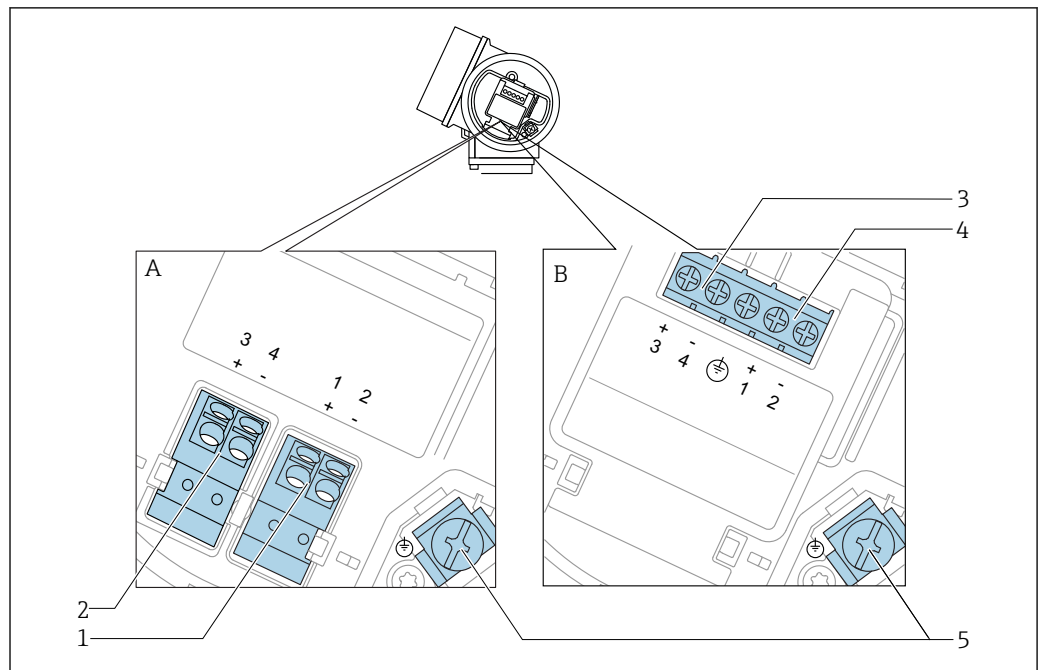

7 Terminal assignment 2-wire: 4-20 mA HART, 4-20 mA

A Without integrated overvoltage protection

B With integrated overvoltage protection

1 Connection current output 1, 4-20 mA HART passive: terminals 1 and 2, without integrated overvoltage protection

2 Connection current output 2, 4-20 mA: terminals 3 and 4, without integrated overvoltage protection

3 Connection current output 2, 4-20 mA: terminals 3 and 4, with integrated overvoltage protection

4 Connection current output 1, 4-20 mA HART passive: terminals 1 and 2, with integrated overvoltage protection

5 Terminal for cable screen

Block diagram 2-wire: 4-20 mA HART, 4-20 mA

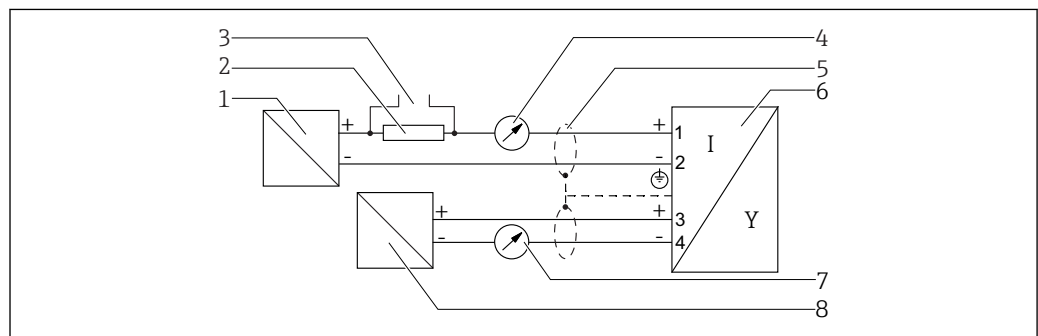

8 Block diagram 2-wire: 4-20 mA HART, 4-20 mA

1 Active barrier with power supply (e.g. RN221N); observe terminal voltage

2 HART communication resistor ($\geq 250 \Omega$); observe maximum load

3 Connection for Commubox FXA195 or FieldXpert SFX350/SFX370 (via VIATOR Bluetooth modem)

4 Analog display device; observe maximum load

5 Cable screen; observe cable specification

6 Measuring device

7 Analog display device; observe maximum load

8 Active barrier with power supply (e.g. RN221N), current output 2; observe terminal voltage

Connection examples for the switch output

i For HART devices, the switch output is available as an option. See product structure, feature 20: "Power Supply, Output", option B: "2-wire; 4-20 mA HART, switch output"

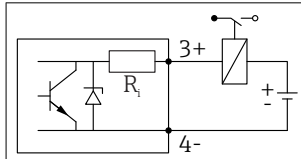

9 Connection of a relay

Suitable relays (examples):

- Solid-state relay: Phoenix Contact OV-24DC/480AC/5 with mounting rail connector UMK-1 OM-R/AMS
- Electromechanical relay: Phoenix Contact PLC-RSC-12DC/21

A0015909

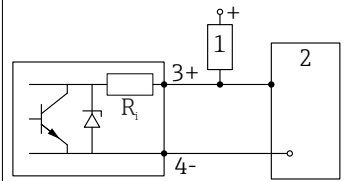

A0015910

10 Connection of a digital input

- 1 Pull-up resistor
- 2 Digital input

i For optimum interference immunity we recommend to connect an external resistor (internal resistance of the relay or Pull-up resistor) of $< 1\,000\ \Omega$.

Device plug connectors

For the versions with fieldbus plug connector (M12 or 7/8"), the signal line can be connected without opening the housing.

Pin assignment of the M12 plug connector

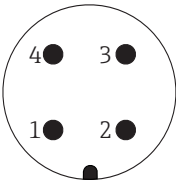
 <small>A0011175</small>	Pin	Meaning
	1	Signal +
	2	not connected
	3	Signal -
	4	Ground

Pin assignment of the 7/8" plug connector

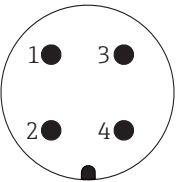
 <small>A0011176</small>	Pin	Meaning
	1	Signal -
	2	Signal +
	3	Not connected
	4	Screen

Supply voltage

An external power supply is necessary.

 Various power supply units can be ordered as an accessory from Endress+Hauser.

2-wire, 4-20 mA HART, passive

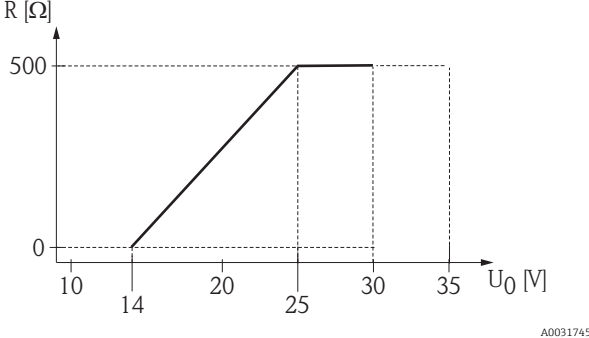
"Power supply, output" ¹⁾	"Approval" ²⁾	Terminal voltage U at device	Maximum load R, depending on the supply voltage U ₀ of the power supply unit
A: 2-wire; 4-20 mA HART	<ul style="list-style-type: none"> ■ Non-hazardous ■ Ex nA ■ Ex ic ■ CSA GP 	14 to 35 V ³⁾	
	Ex ia / IS	14 to 30 V ³⁾	
	<ul style="list-style-type: none"> ■ Ex d(ia) / XP ■ Ex ic(ia) ■ Ex nA(ia) ■ Ex ta / DIP 	14 to 35 V ^{3) 4)}	
	Ex ia + Ex d(ia) / IS + XP	14 to 30 V ³⁾	

- 1) Feature 020 in the product structure
- 2) Feature 010 in the product structure
- 3) If the Bluetooth modem is used, the minimum supply voltage increases by 2 V.
- 4) At ambient temperatures $TT_a \leq -20\text{ °C}$, a terminal voltage $U \geq 16\text{ V}$ is required to start the device with the minimum failure current (3.6 mA).

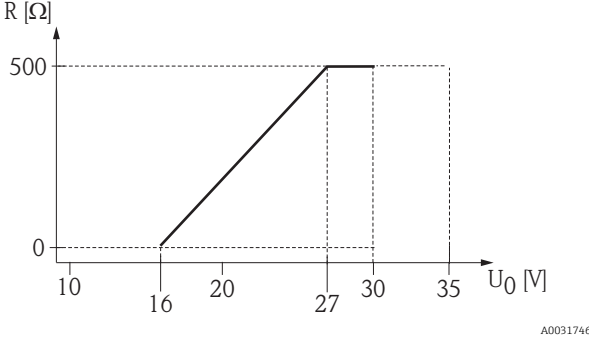
"Power supply, output" ¹⁾	"Approval" ²⁾	Terminal voltage U at device	Maximum load R, depending on the supply voltage U ₀ of the power supply unit
B: 2-wire; 4-20 mA HART, switch output	<ul style="list-style-type: none"> ■ Non-hazardous ■ Ex nA ■ Ex nA(ia) ■ Ex ic ■ Ex ic(ia) ■ Ex d(ia) / XP ■ Ex ta / DIP ■ CSA GP 	16 to 35 V ³⁾	
	<ul style="list-style-type: none"> ■ Ex ia / IS ■ Ex ia + Ex d(ia) / IS + XP 	16 to 30 V ³⁾	

- 1) Feature 020 in the product structure
- 2) Feature 010 in the product structure
- 3) If the Bluetooth modem is used, the minimum supply voltage increases by 2 V.

"Power supply, output" ¹⁾	"Approval" ²⁾	Terminal voltage U at device	Maximum load R, depending on the supply voltage U ₀ of the power supply unit
C: 2-wire; 4-20 mA HART, 4-20 mA	All	16 to 30 V ³⁾	<p>The graph plots Maximum load R [Ω] on the y-axis (0 to 500) against supply voltage U₀ [V] on the x-axis (10 to 35). The load is 0 Ω for U₀ < 16 V. It increases linearly from 0 Ω at 16 V to 500 Ω at 27 V. From 27 V to 30 V, the load is constant at 500 Ω. From 30 V to 35 V, the load is 0 Ω. Dashed lines indicate the points (16, 0), (27, 500), (30, 500), and (35, 0).</p>

A0031746

- 1) Feature 020 in the product structure
- 2) Feature 010 in the product structure
- 3) If the Bluetooth modem is used, the minimum supply voltage increases by 2 V.

Integrated polarity reversal protection	Yes
Permitted residual ripple with f = 0 to 100 Hz	U _{SS} < 1 V
Permitted residual ripple with f = 100 to 10 000 Hz	U _{SS} < 10 mV

Power consumption

"Power supply; Output" ¹⁾	Power consumption
A: 2-wire; 4-20mA HART	< 0.9 W
B: 2-wire; 4-20mA HART, switch output	< 0.9 W
C: 2-wire; 4-20mA HART, 4-20mA	< 2 x 0.7 W

- 1) Feature 020 of the product structure

Current consumption

HART	
Nominal current	3.6 to 22 mA the start-up current for multidrop mode can be parametrized (is set to 3.6 mA on delivery)
Breakdown signal (NAMUR NE43)	adjustable: 3.59 to 22.5 mA

Power supply failure

- Configuration is retained in the HistoROM (EEPROM).
- Error messages (incl. value of operated hours counter) are stored.

Potential equalization

No special measures for potential equalization are required.



If the device is designed for hazardous areas, observe the information in the documentation "Safety Instructions" (XA).

Cable entries

Connection of power supply and signal line

To be selected in feature 050 "Electrical connection"

- Gland M20; Material dependent on the approval:
 - For Non-Ex, ATEX, IECEx, NEPSI Ex ia/ic:
 - Plastics M20x1.5 for cable \varnothing 5 to 10 mm (0.2 to 0.39 in)
 - For Dust-Ex, FM IS, CSA IS, CSA GP, Ex nA:
 - Metal M20x1.5 for cable \varnothing 7 to 10 mm (0.28 to 0.39 in)¹⁾
 - For Ex d:
 - No gland available
- Thread
 - 1/2" NPT
 - G 1/2"
 - M20 x 1.5
- Plug M12 / Plug 7/8"
 - Only available for Non-Ex, Ex ic, Ex ia

Connection of remote display FHX50

Feature 030 "Display, Operation"	Cable entry for FHX50 connection
L: "Prepared for display FHX50 + M12 connection"	M12 socket
M: "Prepared for display FHX50 + M16 gland, custom connection"	M12 cable gland
N: "Prepared for display FHX50 + NPT1/2 thread, custom connection"	NPT1/2 thread

Cable specification

- **Devices without integrated overvoltage protection**
Pluggable spring-force terminals for wire cross-sections 0.5 to 2.5 mm² (20 to 14 AWG)
- **Devices with integrated overvoltage protection**
Screw terminals for wire cross-sections 0.2 to 2.5 mm² (24 to 14 AWG)
- For ambient temperature $T_U \geq 60^\circ\text{C}$ (140 °F): use cable for temperature $T_U + 20\text{ K}$.

HART

- A normal device cable suffices if only the analog signal is used.
- A shielded cable is recommended if using the HART protocol. Observe grounding concept of the plant.

Overvoltage protection

If the measuring device is used for level measurement in flammable liquids which requires the use of overvoltage protection according to DIN EN 60079-14, standard for test procedures 60060-1 (10 kA, pulse 8/20 μs), an overvoltage protection module has to be installed.

Integrated overvoltage protection module

An integrated overvoltage protection module is available for 2-wire HART devices.

Product structure: Feature 610 "Accessory mounted", option NA "Overvoltage protection".

Technical data	
Resistance per channel	2 x 0.5 Ω max.
Threshold DC voltage	400 to 700 V
Threshold impulse voltage	< 800 V
Capacitance at 1 MHz	< 1.5 pF
Nominal arrest impulse voltage (8/20 μs)	10 kA

External overvoltage protection module

HAW562 or HAW569 from Endress+Hauser are suited as external overvoltage protection.

1) The material of the gland is dependent on the housing type; GT19 (plastic housing) and GT20 (aluminum housing): nickel-coated brass (CuZn).

Performance characteristics

Reference operating conditions

- Temperature = +24 °C (+75 °F) ±5 °C (±9 °F)
- Pressure = 960 mbar abs. (14 psia) ±100 mbar (±1.45 psi)
- Humidity = 60 % ±15 %
- Reflector: metal plate with diameter ≥ 1 m (40 in)
- No major interference reflections inside the signal beam

Reference accuracy

Typical data under reference operating conditions: DIN EN IEC 61298-2 / DIN EN IEC 60770-1; percentage values in relation to the span.

Output:	digital	analog ¹⁾
Accuracy (Sum of non-linearity, nonrepeatability and hysteresis) ²⁾	Measuring distance up to 0.8 m (2.62 ft): max. ±4 mm (±0.16 in)	±0.03 %
	Measuring distance > 0.8 m (2.62 ft): ±1 mm (±0.04 in)	±0.02 %
Non-repeatability ³⁾	≤ 1 mm (0.04 in)	

- 1) Add error of the analogous value to the digital value.
- 2) If the reference conditions are not met, the offset/zero point arising from the mounting conditions may be up to ±4 mm (0.16 in). This additional offset/zero point can be compensated for by entering a correction (parameter "level correction") during commissioning.
- 3) The non-repeatability is already considered in the accuracy.

Differing values in near-range applications

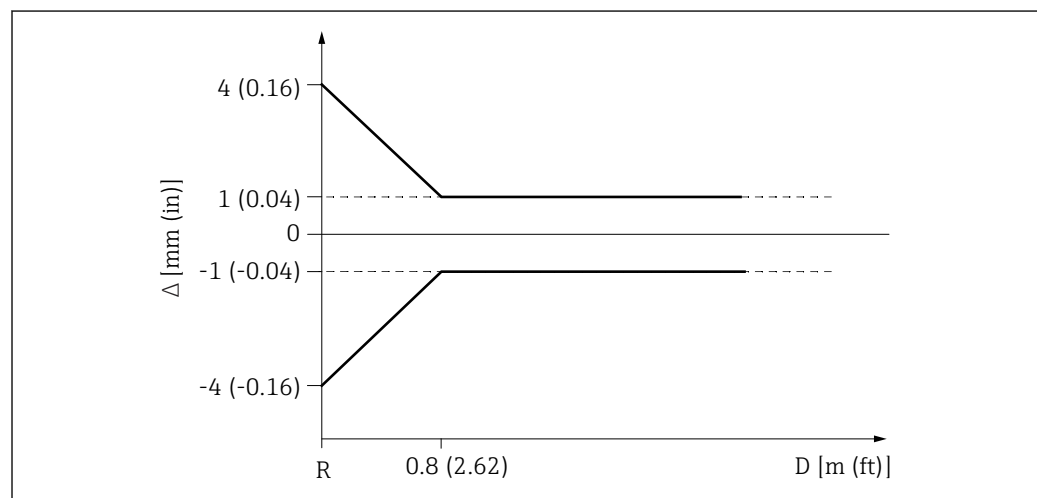

11 Maximum measured error in near-range applications

- Δ Maximum measured error
 R Reference point of the distance measurement
 D Distance from reference point of antenna

Measured value resolution

Dead band according to DIN EN IEC 61298-2 / DIN EN IEC 60770-1:

- Digital: 1 mm
- Analog: 1 μA

Response time

The response time can be configured. The following step response times (in accordance with DIN EN IEC 61298-2 / DIN EN IEC 60770-1)²⁾ are when damping is switched off:

- 2) According to DIN EN IEC 61298-2 / DIN EN IEC 60770-1, the step response time is the time that elapses after an abrupt change in the input signal until the change in the output signal has adopted 90% of the steady-state value for the first time.

Sampling rate	$\geq 1.3 \text{ s}^{-1}$ at $U \geq 24 \text{ V}$
Response time	$< 3.6 \text{ s}$

Influence of ambient temperature

The measurements are performed according to DIN EN IEC 61298-3 / DIN EN IEC 60770-1

- Digital (HART): average $T_K = 2 \text{ mm}/10 \text{ K}$
- Analog (current output):
 - Zero point (4 mA): average $T_K = 0.02 \text{ \%}/10 \text{ K}$
 - Span (20 mA): average $T_K = 0.05 \text{ \%}/10 \text{ K}$

Influence of gas phase

High pressure reduces the speed of propagation of the measuring signals in the gas/vapor above the medium. This effect depends on the type of gas phase and its temperature. This results in a systematic measured error that increases with increasing distance between the reference point of the measurement (flange) and the surface of the product. The following table shows this measured error for a few typical gases/vapors (with regard to the distance, a positive value means that a too large distance is measured):

Gas phase	Temperature		Pressure		
	°C	°F	1 bar (14,5 psi)	10 bar (145 psi)	25 bar (362 psi)
Air/nitrogen	20	68	0.00 %	0.22 %	0.58 %
	200	392	-0.01 %	0.13 %	0.36 %
	400	752	-0.02 %	0.08 %	0.29 %
Hydrogen	20	68	-0.01 %	0.10 %	0.25 %
	200	392	-0.02 %	0.05 %	0.17 %
	400	752	-0.02 %	0.03 %	0.11 %
Water (saturated steam)	100	212	0.02 %	-	-
	180	356	-	2.1 %	-
	263	505,4	-	-	4.15 %
	310	590	-	-	-
	364	687	-	-	-

 With a known, constant pressure, it is possible to compensate for this measured error with a linearization, for example.

Installation

Installation conditions

Orientation - Liquid media

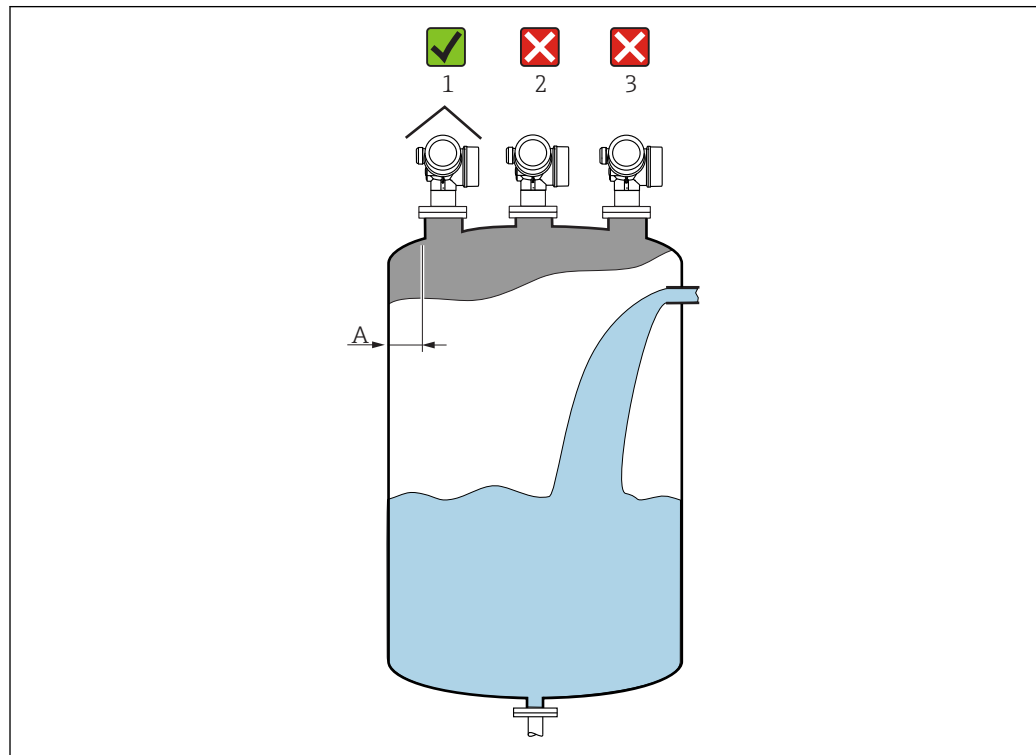

- Recommended distance **A** wall - nozzle outer edge: $\sim 1/6$ of the container diameter. However, the device must not under any circumstances be mounted closer than 15 cm (5.91 in) to the tank wall.
- Not in the center (2) as interference can cause signal loss.
- Not above the filling curtain (3).
- The use of a weather protection cover (1) is recommended to protect the transmitter from direct sunlight or rain.

Internal container fittings

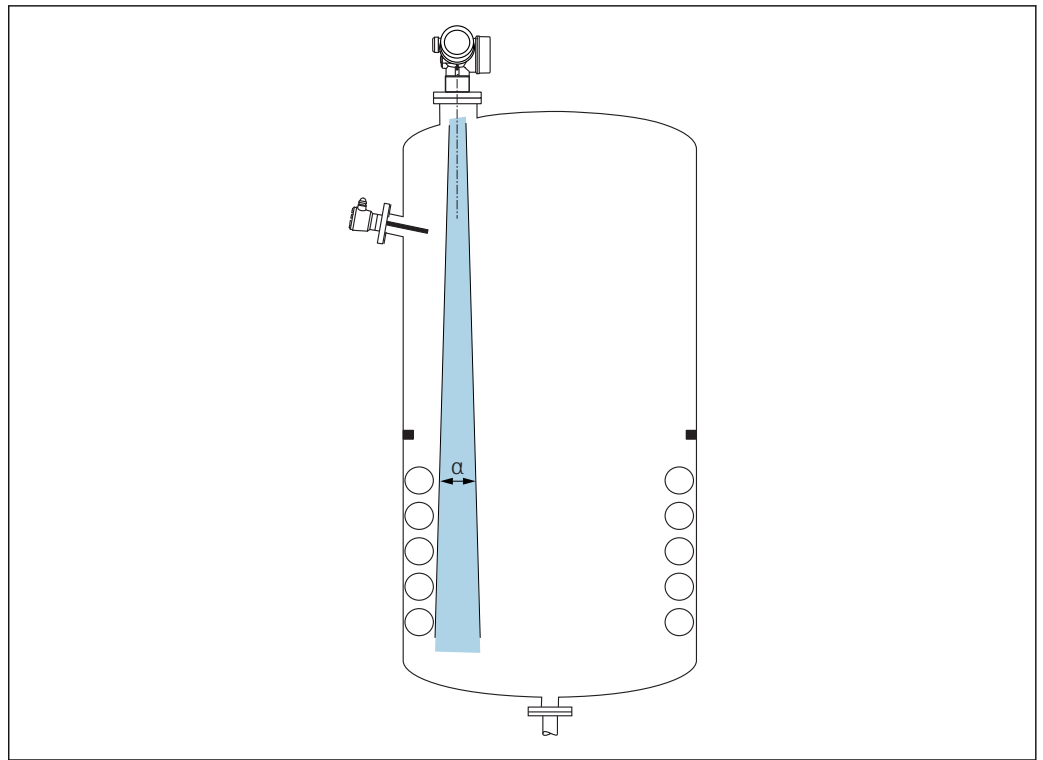

A0031777

Avoid the location of internal fittings (limit switches, temperature sensors, struts, vacuum rings, heating coils, baffles etc.) inside the signal beam. Take into account the beam angle → 26.

Avoiding interference echoes

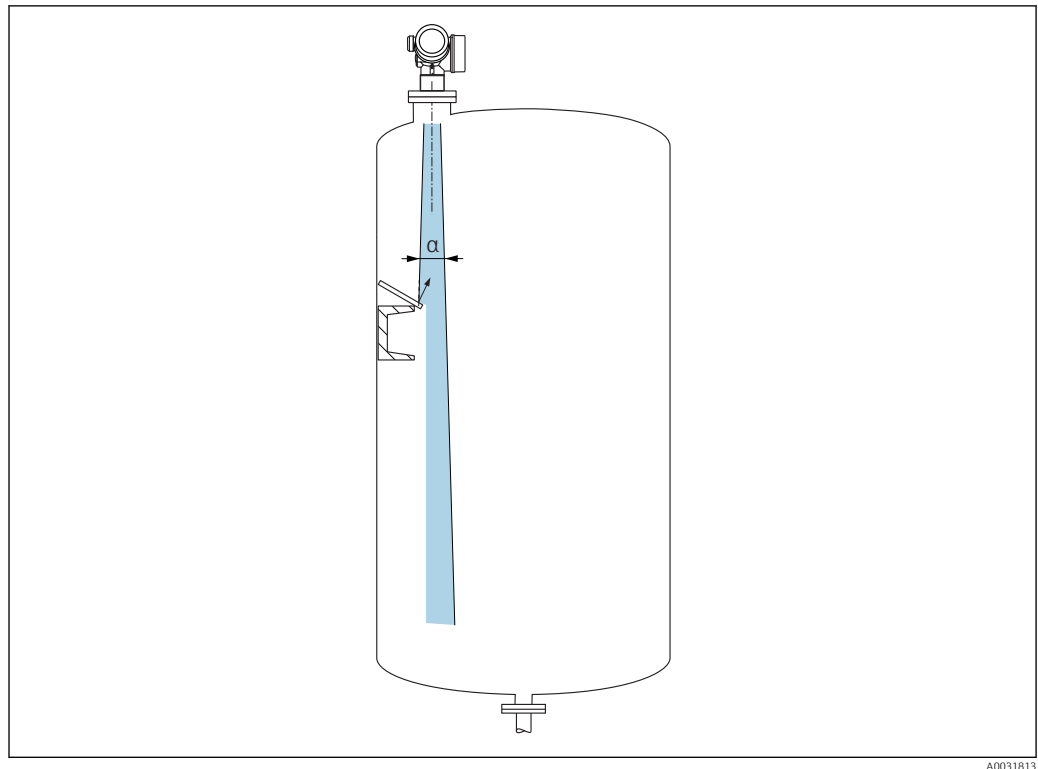

A0031813

Metal deflector plates, installed at an angle to scatter the radar signals, help prevent interference echoes.

Optimization options

- Antenna size
The larger the antenna the smaller the beam angle α , resulting in fewer interference echoes
→  26.
- Mapping
Measurement can be optimized by electronically suppressing interference echoes.

Beam angle

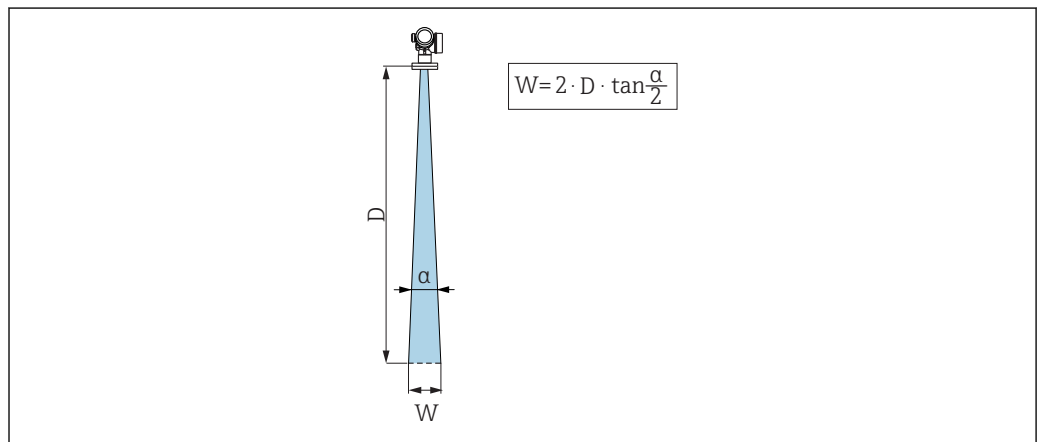

A0031824

 12 Relationship between beam angle α , distance D and beamwidth diameter W

The beam angle is defined as the angle α where the energy density of the radar waves reaches half the value of the maximum energy density (3dB width). Microwaves are also emitted outside the signal beam and can be reflected off interfering installations.

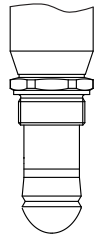
FMR60	
	
Antenna ¹⁾	Drip-off, PTFE 50 mm / 2"
Beam angle α	6°
Distance (D)	Beamwidth diameter W
5 m (16 ft)	0.52 m (1.70 ft)
10 m (33 ft)	1.05 m (3.44 ft)
15 m (49 ft)	1.57 m (5.15 ft)
20 m (66 ft)	2.10 m (6.89 ft)
25 m (82 ft)	2.62 m (8.60 ft)
30 m (98 ft)	3.14 m (10.30 ft)
35 m (115 ft)	3.67 m (12.04 ft)
40 m (131 ft)	4.19 m (13.75 ft)
45 m (148 ft)	4.72 m (15.49 ft)
50 m (164 ft)	5.24 m (17.19 ft)

A0032080

1) Order code 070 in product structure

Measurement through a ball valve

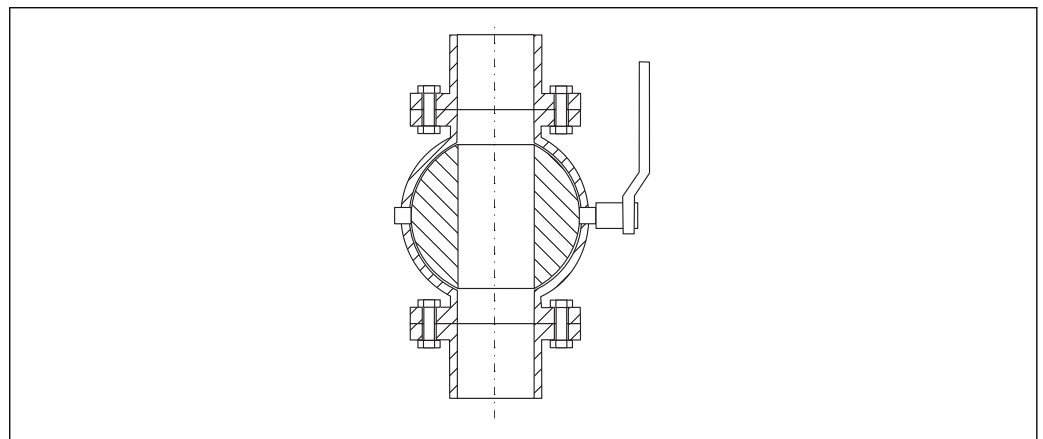

A0034564

- Measurements can be performed through an open full bore ball valve without any problems.
- At the transitions, no gap may be left exceeding 1 mm (0.04 in).
- Diameter of opening of ball valve must always be equivalent to pipe diameter; avoid edges and constrictions.

External measurement through plastic cover or dielectric windows

- Dielectric constant of medium: $\epsilon_r \geq 10$
- The distance from the tip of the antenna to the tank should be approx. 100 mm (4 in).
- If possible, avoid installation positions in which condensate or buildup can form between the antenna and the vessel.
- In the case of outdoor installations, ensure that the area between the antenna and the tank is protected from the weather.
- Do not install any fittings or attachments between the antenna and the tank that could reflect the signal.

Suitable thickness of tank roof or window

Material	PE	PTFE	PP	Perspex
ϵ_r (Dielectric constant of medium)	2.3	2.1	2.3	3.1
Optimum thickness	1.25 mm (0.049 in) ¹⁾	1.3 mm (0.051 in) ¹⁾	1.25 mm (0.049 in) ¹⁾	1.07 mm (0.042 in) ¹⁾

- 1) or an integer that is a multiple of this value; it should be noted here that the microwave transparency decreases significantly with increasing window thickness.

Installation: Drip-off antenna, PTFE 50 mm / 2"**FMR60 - Aligning the antenna axis**

Align the antenna vertically to the product surface.

i Attention:

The maximum reach of the antenna can be reduced if it is not installed perpendicular to the product.

Radial alignment of the antenna

Based on the directional characteristic, radial alignment of the antenna is not necessary.

Information concerning nozzles

The maximum nozzle length H_{max} depends on the nozzle diameter D :

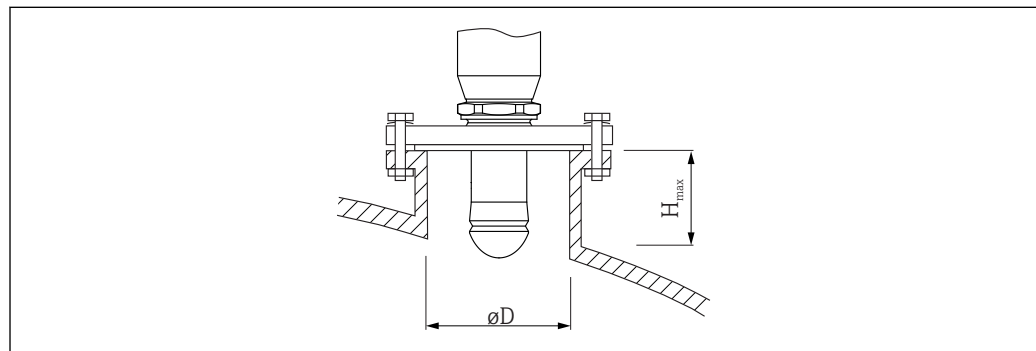

A0032209

Nozzle diameter ($\varnothing D$)	Maximum nozzle length (H_{max}) ¹⁾
50 to 80 mm (2 to 3.2 in)	750 mm (30 in)
80 to 100 mm (3.2 to 4 in)	1 150 mm (46 in)

Nozzle diameter (ØD)	Maximum nozzle length (H _{max}) ¹⁾
100 to 150 mm (4 to 6 in)	1 450 mm (58 in)
≥150 mm (6 in)	2 200 mm (88 in)

1) In the case of longer nozzles, a reduced measuring performance must be anticipated.



Note the following if the antenna does not project out of the nozzle:

- The end of the nozzle must be smooth and free from burrs. The edge of the nozzle should be rounded if possible.
- Mapping must be performed.
- Please contact Endress+Hauser for applications with nozzles that are higher than indicated in the table.

Information concerning threaded connections

- When screwing in, turn by the hex bolt only.
- Tool: open-ended wrench 55 mm
- Maximum permissible torque: 50 Nm (36 lbf ft)

Container with heat insulation

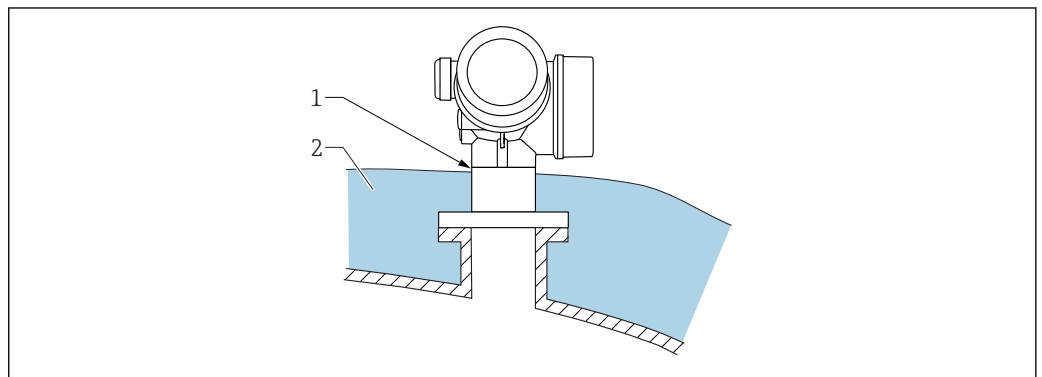

A0032207

If process temperatures are high, the device should be included in the usual container insulation system (2) to prevent the electronics from heating as a result of thermal radiation or convection. The insulation should not be higher than the neck of the device (1).

Environment

Ambient temperature range

Measuring device	-40 to +80 °C (-40 to +176 °F)
Local display	-20 to +70 °C (-4 to +158 °F), the readability of the display may be impaired at temperatures outside the temperature range.

Outdoor operation in strong sunlight:

- Mount the device in the shade.
- Avoid direct sunlight, particularly in warm climatic regions.
- Use a weather protection cover (see accessories).

Ambient temperature limits

i The following diagrams only consider functional aspects. Additional restrictions may apply for certified device versions. See the separate Safety Instructions for more information → 69.

In the event of temperature (T_p) at the process connection, the permitted ambient temperature (T_a) is reduced as indicated in the following diagram (temperature derating) in the table header.

FMR60 Seal ¹⁾ A3: FKM Viton GLT, -40 to 80 °C (-40 to 176 °F)											
A0032024											
Temperature specifications: °C (°F)											
Housing type ²⁾	P1		P2		P3		P4		P5		
	T_p	T_a	T_p	T_a	T_p	T_a	T_p	T_a	T_p	T_a	
A: GT19 two-chamber Plastic PBT	-40 (-40)	60 (140)	60 (140)	60 (140)	80 (176)	54 (129.2)	80 (176)	-40 (-40)	-40 (-40)	-40 (-40)	
C: GT20 two-chamber Aluminum, coated	-40 (-40)	76 (168.8)	76 (168.8)	76 (168.8)	80 (176)	76 (168.8)	80 (176)	-40 (-40)	-40 (-40)	-40 (-40)	

- 1) Feature 090 in the product structure
- 2) Feature 040 in the product structure

FMR60 Seal ¹⁾ A4: FKM Viton GLT, -40 to 130 °C (-40 to 266 °F)												
A0032025												
Temperature specifications: °C (°F)												
Housing type ²⁾	P1		P2		P2+		P3		P4		P5	
	T_p	T_a	T_p	T_a	T_p	T_a	T_p	T_a	T_p	T_a	T_p	T_a
A: GT19 two-chamber Plastic PBT	-40 (-40)	60 (140)	60 (140)	60 (140)	113 (235.4)	45 (113)	130 (266)	22 (71.6)	130 (266)	-40 (-40)	-40 (-40)	-40 (-40)
C: GT20 two-chamber Aluminum, coated	-40 (-40)	76 (168.8)	76 (168.8)	76 (168.8)	110 (230)	71 (159.8)	130 (266)	60 (140)	130 (266)	-40 (-40)	-40 (-40)	-40 (-40)

- 1) Feature 090 in the product structure
- 2) Feature 040 in the product structure

Storage temperature	-40 to +80 °C (-40 to +176 °F)
Climate class	DIN EN 60068-2-38 (test Z/AD)
Altitude according to IEC61010-1 Ed.3	<ul style="list-style-type: none"> ■ Generally up to 2 000 m (6 600 ft) above MSL. ■ Above 2 000 m (6 600 ft) if the following conditions are met: <ul style="list-style-type: none"> - Ordering feature 020 "Power supply; Output" = A, B, C, E or G (2-wire versions) - Supply voltage U < 35 V - Supply voltage of overvoltage category 1
Degree of protection	<ul style="list-style-type: none"> ■ With closed housing tested according to: <ul style="list-style-type: none"> - IP68, NEMA6P (24 h at 1.83 m under water surface) - For plastic housing with transparent cover (display module): IP68 (24 h at 1.00 m under water surface)³⁾ - IP66, NEMA4X ■ With open housing: IP20, NEMA1 ■ Display module: IP22, NEMA2 <p> Degree of protection IP68 NEMA6P applies for M12 PROFIBUS PA plugs only when the PROFIBUS cable is plugged in and is also rated IP68 NEMA6P.</p>
Vibration resistance	DIN EN 60068-2-64 IEC 60068-2-64 at 5 to 2 000 Hz: 1.5 (m/s ²) ² /Hz
Electromagnetic compatibility (EMC)	<p>Electromagnetic compatibility in accordance with all of the relevant requirements outlined in the EN 61326 series and NAMUR Recommendation EMC (NE 21). For details, please refer to the Declaration of Conformity⁴⁾.</p> <p>A normal device cable suffices if only the analog signal should be used. Use a shielded cable for digital communication (HART/ PA/ FF).</p> <p>Maximum measured error during EMC testing: <0.5 % of the span. By way of derogation, for devices with a plastic housing and see-through lid (integrated display SD02 or SD03) the measured error can be up to 2 % of the span in the event of strong electromagnetic radiation in the 1 to 2 GHz frequency range.</p>

3) This restriction is valid if the following options of the product structure have been selected at the same time: 030 ("Display, Operation") = C ("SD02") or E ("SD03"); 040 ("Housing") = A ("GT19").

4) Available for download at www.de.endress.com.

Process

Process temperature, process pressure

i The pressure ranges indicated can be reduced by the choice of process connection. The nominal pressure (PN) indicated on the nameplate refers to a reference temperature of 20 °C, and of 100 °F for ASME flanges. Observe pressure-temperature dependency.

Please refer to the following standards for the pressure values permitted at higher temperatures:

- EN 1092-1: 2001 Tab. 18

In terms of their stability-temperature property, the materials 1.4435 and 1.4404 are grouped in EN 1092-1 table 18 under 13E0. The chemical composition of the two materials can be identical.

- ASME B 16.5a – 1998 Tab. 2-2.2 F316
- ASME B 16.5a – 1998 Tab. 2.3.8 N10276
- JIS B 2220

FMR60 threaded process connection

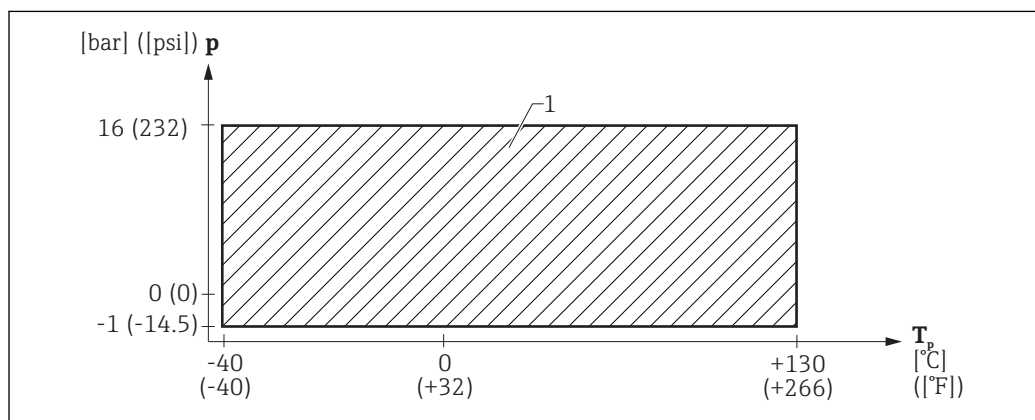

A0032614

13 FMR60: Permitted range for process temperature and process pressure

1 Feature 90, seal: A4, FKM Viton GLT

FMR60 threaded process connection

Feature 100 "Process connection"	Feature 90 "Seal"	Process temperature range	Process pressure range
<ul style="list-style-type: none"> ▪ GGJ: Thread ISO228 G1-1/2 ▪ RGJ: Thread ANSI MNPT1-1/2 	<ul style="list-style-type: none"> A4: FKM Viton GLT 	-40 to +130 °C (-40 to +266 °F)	$P_{rel} =$ -1 to 16 bar (-14.5 to 232 psi) ¹⁾

1) The pressure range may be further restricted in the event of a CRN approval

FMR60 flange process connection

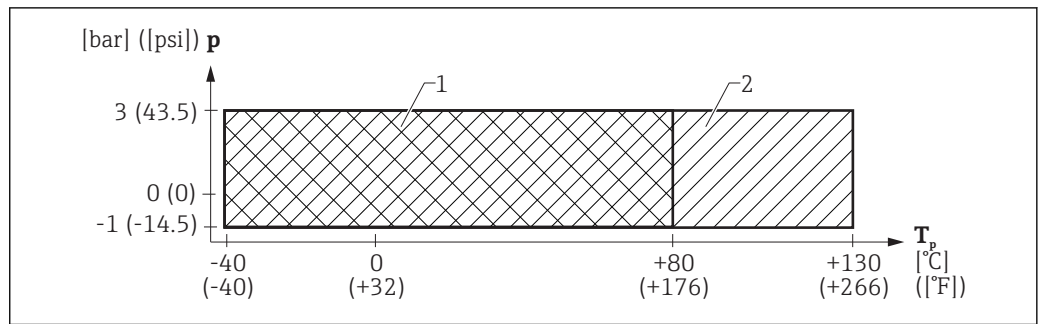

14 FMR60: Permitted range for process temperature and process pressure

- 1 Process connection: flange PP
- 2 Process connection: flange 316L

FMR60 flange process connection

Feature 100 "Process connection"	Process temperature range	Process pressure range
<ul style="list-style-type: none"> ▪ XJG: UNI flange 3"/DN80/80A, PP ▪ XKG: UNI flange 4"/DN100/100A, PP ▪ XLG: UNI flange 6"/DN150/150A, PP 	-40 to +80 °C (-40 to +176 °F)	$p_{rel} = -1$ to 3 bar (-14.5 to 43.5 psi) $p_{abs} < 4$ bar (58 psi) ¹⁾
<ul style="list-style-type: none"> ▪ XJJ: UNI flange 3"/DN80/80A, 316L ▪ XKJ: UNI flange 4"/DN100/100A, 316L ▪ XLJ: UNI flange 6"/DN150/150A, 316L 	-40 to +130 °C (-40 to +266 °F)	

1) The pressure range may be further restricted in the event of a CRN approval

Dielectric constant

For liquids

$\epsilon_r \geq 1.9$

Please contact Endress+Hauser for applications with lower dielectric constants than indicated.



For dielectric constants (DC values) of many media commonly used in various industries refer to:

- the Endress+Hauser DC manual (CP01076F)
- the Endress+Hauser "DC Values App" (available for Android and iOS)

Minimum level in case of small dielectric constants

80 mm (3.15 in) above the tank bottom



- This minimum level is valid for media with $\epsilon_r \leq 4$.
- In case of lower levels the tank bottom may be visible through the medium, which results in a reduced measuring accuracy.

Mechanical construction

Dimensions

Dimensions of the electronics housing

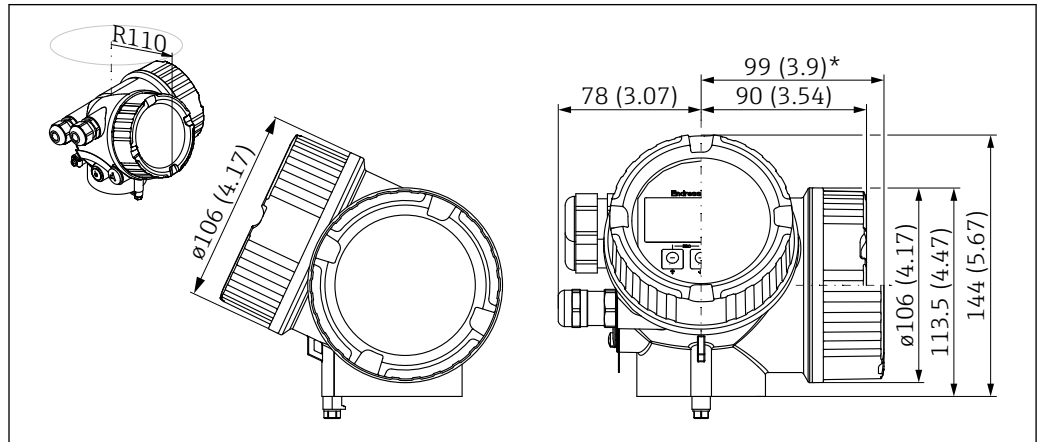

A0011346

15 Housing GT19 (Plastics PBT); Dimensions in mm (in)

*for devices with integrated overvoltage protection.

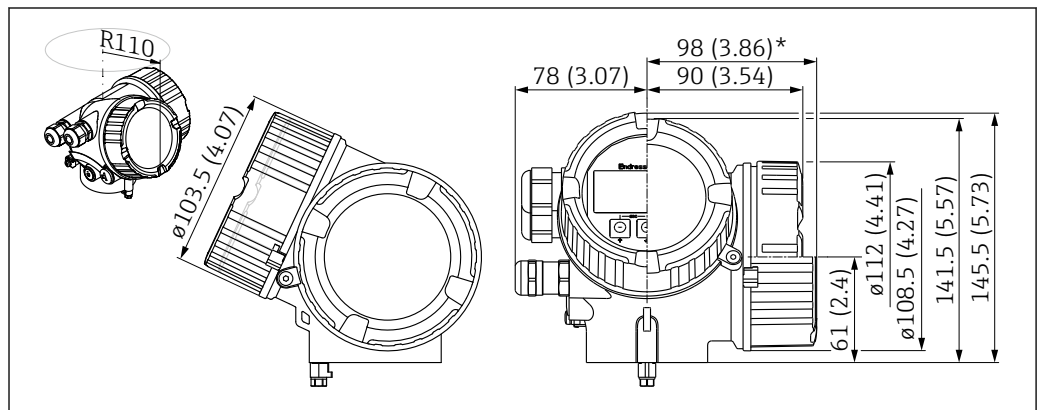

A0020751

16 Housing GT20 (Alu coated); Dimensions in mm (in)

*for devices with integrated overvoltage protection.

FMR60: Antenna and process connection

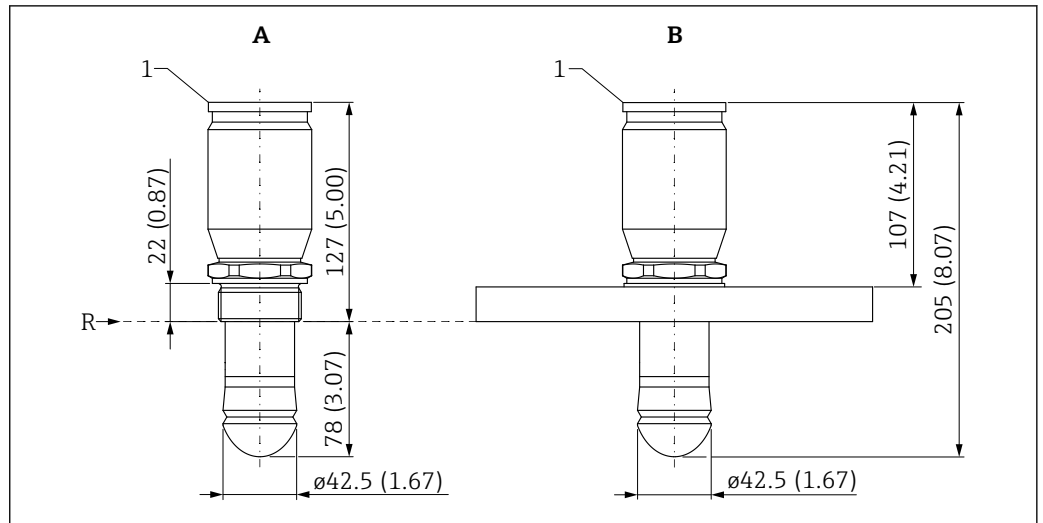

A0031560

17 Dimensions: mm (in)

A Process connection: G1-1/2" or MNPT1-1/2" thread

B Process connection: UNI flange 3"/DN80/80A to 6"/DN150/150A

R Reference point of the measurement

1 Bottom edge of housing

UNI flanges for FMR60

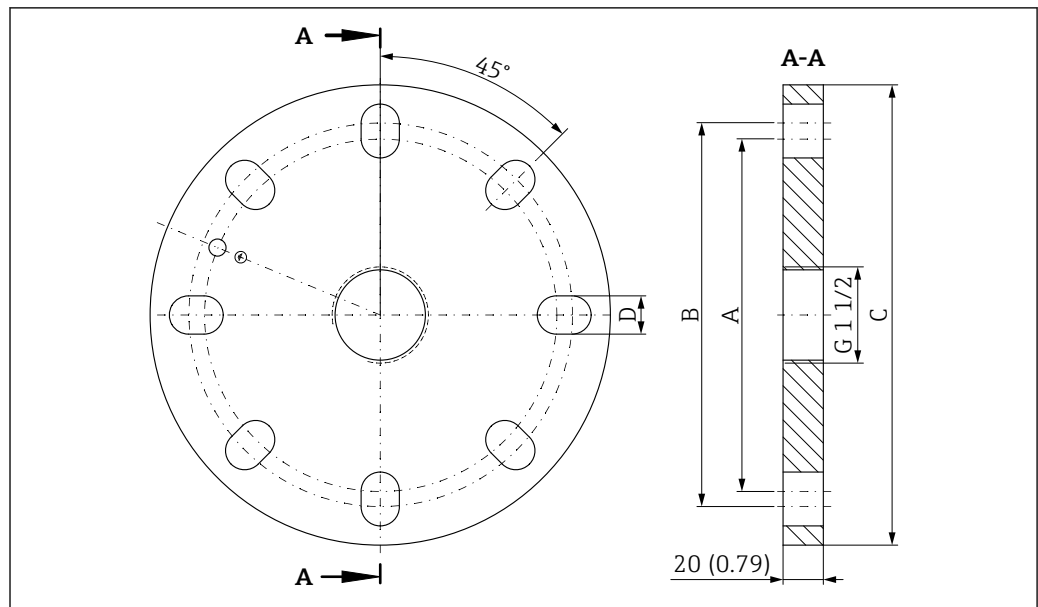

A0034611

18 Dimensions: mm (in)

Feature 100: process connection	Suitable for	A	B	C	D
<ul style="list-style-type: none"> ▪ XJG: UNI flange 3"/DN80/80A, PP ▪ XJJ: UNI flange 3"/DN80/80A, 316L 	<ul style="list-style-type: none"> ▪ 3" 150lbs ▪ DN80 PN16 ▪ 10K 80A 	150 mm (5.9 in)	160 mm (6.3 in)	200 mm (7.9 in)	19 mm (0.75 in)
<ul style="list-style-type: none"> ▪ XKG: UNI flange 4"/DN100/100A, PP ▪ XKJ: UNI flange 4"/DN100/100A, 316L 	<ul style="list-style-type: none"> ▪ 4" 150lbs ▪ DN100 PN16 ▪ 10K 100A 	175 mm (6.9 in)	190.5 mm (7.5 in)	228.6 mm (9 in)	19 mm (0.75 in)
<ul style="list-style-type: none"> ▪ XLG: UNI flange 6"/DN150/150A, PP ▪ XLJ: UNI flange 6"/DN150/150A, 316L 	<ul style="list-style-type: none"> ▪ 6" 150lbs ▪ DN150 PN16 ▪ 10K 150A 	240 mm (9.4 in)	241.3 mm (9.5 in)	285 mm (11.2 in)	23 mm (0.9 in)

Weight

Housing

Part	Weight
GT19 housing - plastic	Approx. 1.2 kg (2.7 lb)
GT20 housing - aluminum	Approx. 1.9 kg (4.2 lb)

Antenna and process connection

Device	Antenna ¹⁾	Weight of antenna / process connection
FMR60	GA: Drip-off, PTFE DN50	Max. 2 kg (4.41 lb) + flange weight ²⁾

1) Order code 070

2) For flange weights (316/316L) see Technical Information TI00426F.

Materials: GT19 housing (plastic)

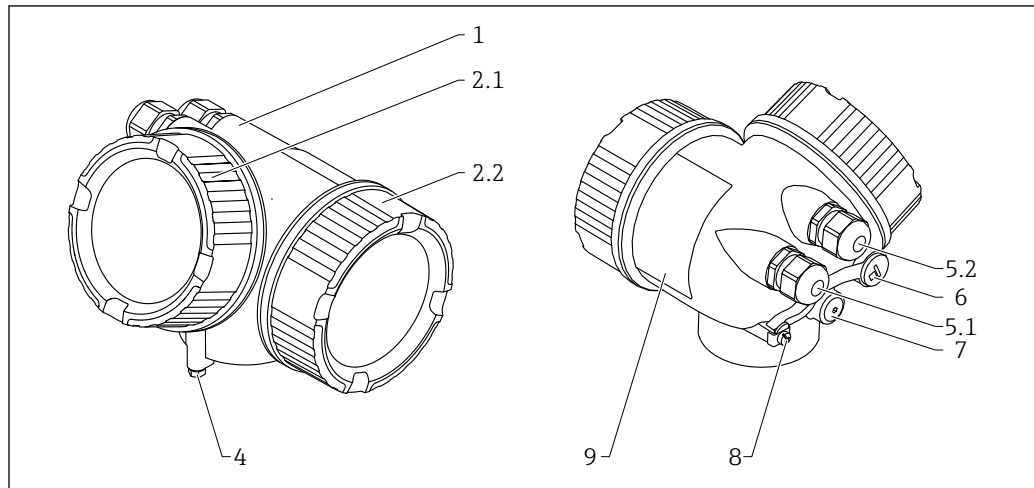

A0013788

No.	Part	Material
1	Housing	PBT
2.1	Cover of the electronics compartment	<ul style="list-style-type: none"> ■ Cover glass: PC ■ Cover frame: PBT-PC ■ Cover seal: EPDM ■ Thread-coating: Graphite-based lubricant varnish
2.2	Cover of the terminal compartment	<ul style="list-style-type: none"> ■ Cover: PBT ■ Cover seal: EPDM ■ Thread-coating: Graphite-based lubricant varnish
4	Lock at the housing neck	<ul style="list-style-type: none"> ■ Screw: A4-70 ■ Clamp: 316L (1.4404)
5.1	Dummy plug, cable gland, adapter or plug (depending on the device version)	<ul style="list-style-type: none"> ■ Dummy plug, depending on the device version: <ul style="list-style-type: none"> - PE - PBT-GF ■ Cable gland, depending on the device version: <ul style="list-style-type: none"> - Nickel-plated brass (CuZn) - PA ■ Adapter: 316L (1.4404/1.4435) ■ Seal: EPDM ■ M12 plug: Nickel-plated brass ¹⁾ ■ 7/8" plug: 316 (1.4401) ²⁾
5.2	Dummy plug, cable gland or adapter (depending on the device version)	<ul style="list-style-type: none"> ■ Dummy plug, depending on the device version: <ul style="list-style-type: none"> - PE - PBT-GF - Nickel-plated steel ■ Cable gland, depending on the device version: <ul style="list-style-type: none"> - Nickel-plated brass (CuZn) - PA ■ Adapter: 316L (1.4404/1.4435) ■ Seal: EPDM
6	Dummy plug or M12 socket (depending on the device version)	<ul style="list-style-type: none"> ■ Dummy plug: Nickel-plated brass (CuZn) ■ M12 socket: Nickel-plated GD-Zn
7	Pressure relief stopper	Nickel-plated brass (CuZn)
8	Ground terminal	<ul style="list-style-type: none"> ■ Screw: A2 ■ Spring washer: A4 ■ Clamp: 304 (1.4301) ■ Holder: 304 (1.4301)
9	Adhesive nameplate	Plastic

1) For the version with M12 plug the sealing material is Viton.
 2) For the version with 7/8" plug, the sealing material is NBR.

**Materials: GT20 housing
(die-cast aluminum, powder-coated)**

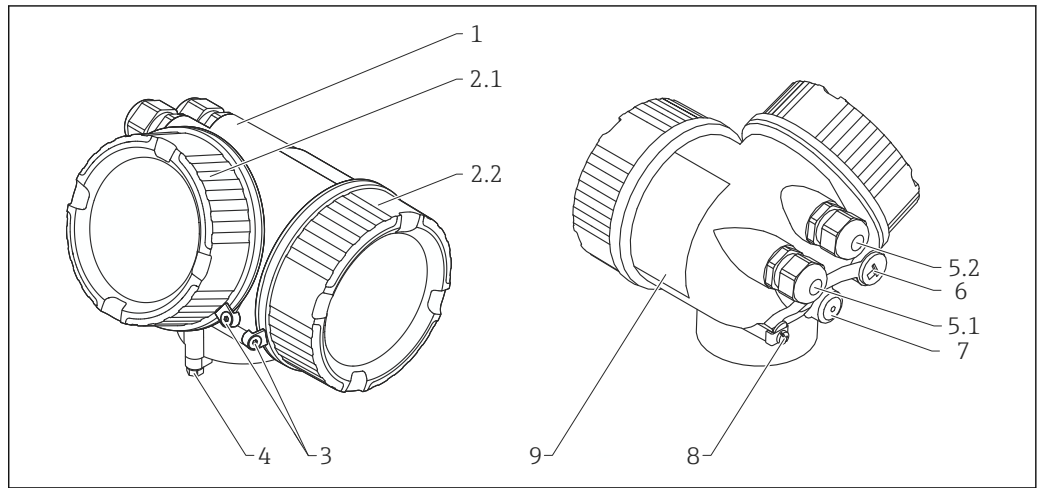

A0036037

Nr.	Part	Material
1	Housing, RAL 5012 (blue)	<ul style="list-style-type: none"> ▪ Housing: AlSi10Mg(<0,1% Cu) ▪ Coating: Polyester
2.1	Cover of the electronics compartment; RAL 7035 (gray)	<ul style="list-style-type: none"> ▪ Cover: AlSi10Mg(<0,1% Cu) ▪ Window: Glass ▪ Cover seal: NBR ▪ Seal of the window: NBR ▪ Thread-coating: Graphite-based lubricant varnish
2.2	Cover of the terminal compartment; RAL 7035 (gray)	<ul style="list-style-type: none"> ▪ Cover: AlSi10Mg(<0,1% Cu) ▪ Cover seal: NBR ▪ Thread-coating: Graphite-based lubricant varnish
3	Cover lock	<ul style="list-style-type: none"> ▪ Screw: A4 ▪ Clamp: 316L (1.4404)
4	Lock at the housing neck	<ul style="list-style-type: none"> ▪ Screw: A4-70 ▪ Clamp: 316L (1.4404)
5.1	Dummy plug, cable gland, adapter or plug (depending on the device version)	<ul style="list-style-type: none"> ▪ Dummy plug, depending on the device version: <ul style="list-style-type: none"> - PE - PBT-GF ▪ Cable gland, depending on the device version: <ul style="list-style-type: none"> - Nickel-plated brass (CuZn) - PA ▪ Adapter: 316L (1.4404/1.4435) ▪ Seal: EPDM ▪ M12 plug: Nickel-plated brass¹⁾ ▪ 7/8" plug: 316 (1.4401)²⁾
5.2	Dummy plug, cable gland or adapter (depending on the device version)	<ul style="list-style-type: none"> ▪ Dummy plug, depending on the device version: <ul style="list-style-type: none"> - PE - PBT-GF - Nickel-plated steel ▪ Cable gland, depending on the device version: <ul style="list-style-type: none"> - Nickel-plated brass (CuZn) - PA ▪ Adapter: 316L (1.4404/1.4435) ▪ Seal: EPDM
6	Dummy plug or M12 socket (depending on the device version)	<ul style="list-style-type: none"> ▪ Dummy plug : Nickel-plated brass (CuZn) ▪ M12 socket: Nickel-plated GD-Zn
7	Pressure relief stopper	Nickel-plated brass (CuZn)

Nr.	Part	Material
8	Ground terminal	<ul style="list-style-type: none"> ▪ Screw: A2 ▪ Spring washer: A2 ▪ Clamp: 304 (1.4301) ▪ Holder: 304 (1.4301)
9	Adhesive nameplate	Plastic

- 1) For the version with M12 plug the sealing material is Viton.
 2) For the version with 7/8" plug, the sealing material is NBR.

Materials: antenna and process connection

FMR60

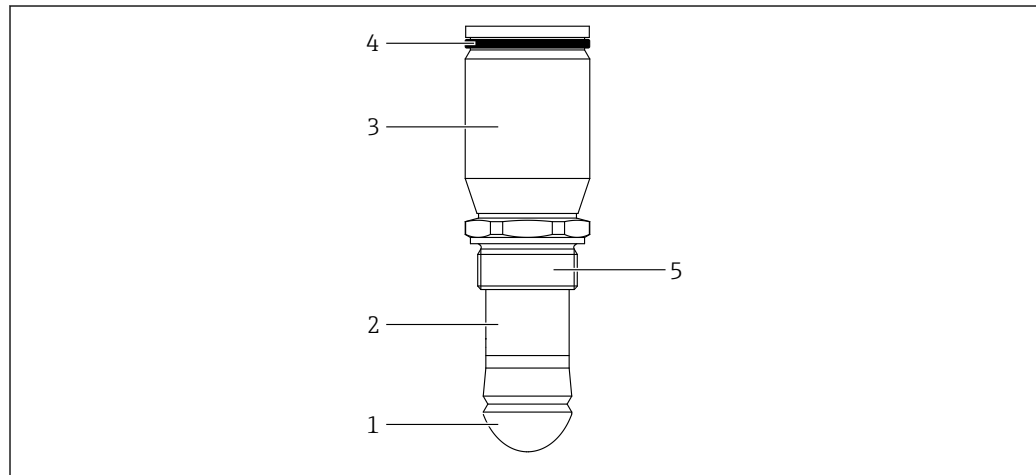

A0031812

No.	Component part	Material
1	Antenna	Antenna: PTFE Antenna seal: Viton (FKM)
2	Antenna adapter	316L / 1.4404
3	Housing adapter	316L / 1.4404
4	Housing seal	EPDM
5	Process connection	316L / 1.4404

Materials: Weather protection cover

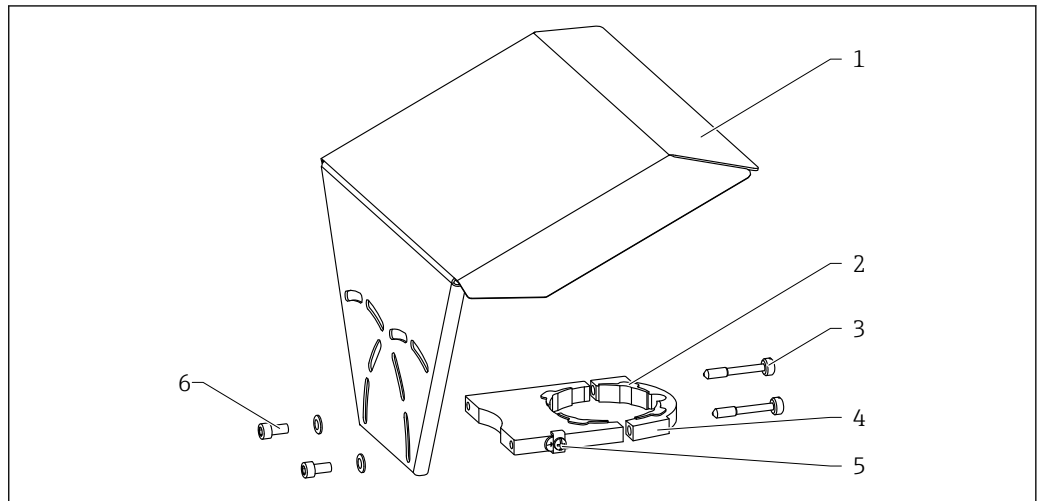

A0015473

No	Part: Material
1	Protection cover: 316L (1.4404)
2	Molded rubber part (4x): EPDM
3	Clamping screw: 316L (1.4404) + carbon fibre
4	Bracket: 316L (1.4404)
5	Ground terminal <ul style="list-style-type: none"> ▪ Screw: A4 ▪ Spring washer: A4 ▪ Clamp: 316L (1.4404) ▪ Holder: 316L (1.4404)
6	<ul style="list-style-type: none"> ▪ Washer: A4 ▪ Cheese head screw: A4-70

Operability

Operating concept

Operator-oriented menu structure for user-specific tasks

- Commissioning
- Operation
- Diagnostics
- Expert level

Operating languages

- English
- Deutsch
- Français
- Español
- Italiano
- Nederlands
- Portuguesa
- Polski
- русский язык (Russian)
- Svenska
- Türkçe
- 中文 (Chinese)
- 日本語 (Japanese)
- 한국어 (Korean)
- Bahasa Indonesia
- tiếng Việt (Vietnamese)
- čeština (Czech)



Feature 500 of the product structure determines which of these languages is preset on delivery.

Quick and save commissioning

- Interactive wizard with graphical interface for easy commissioning via FieldCare/DeviceCare
- Menu guidance with brief explanations of the individual parameter functions
- Standardized operation at the device and in the operating tools

Integrated data storage device (HistoROM)

- Enables transfer of configuration when changing electronic modules
- Records up to 100 event messages in the device
- Records up to 1000 measured values in the device
- Saves the signal curve on commissioning which can later be used as a reference.

Efficient diagnostics increase measurement reliability

- Remedy information is integrated in plain text
- Diverse simulation options and line recorder functions

Integrated Bluetooth module (option for HART devices)

- Easy and fast setup via SmartBlue (app)
- No additional tools or adapters required
- Signal curve via SmartBlue (app)
- Encrypted single point-to-point data transmission (Fraunhofer-Institut, third party, tested) and password-protected communication via Bluetooth® wireless technology

Local operation

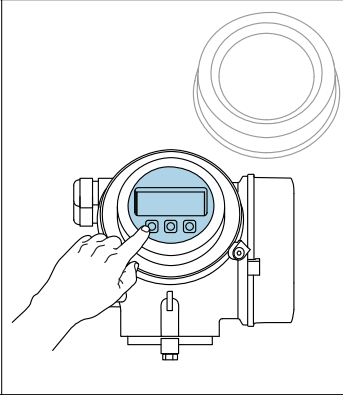
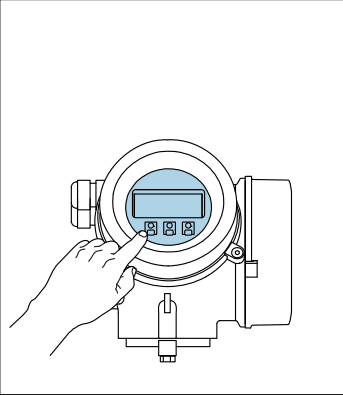
Operation with	Pushbuttons	Touch Control
Order code for "Display; Operation"	Option C "SD02"	Option E "SD03"
		
Display elements	4-line display	4-line display white background lighting; switches to red in event of device error
	Format for displaying measured variables and status variables can be individually configured	
	Permitted ambient temperature for the display: -20 to +70 °C (-4 to +158 °F) The readability of the display may be impaired at temperatures outside the temperature range.	
Operating elements	local operation with 3 push buttons (⊕, ⊖, ⊞)	external operation via touch control; 3 optical keys: ⊕, ⊖, ⊞
	Operating elements also accessible in various hazardous areas	
Additional functionality	Data backup function The device configuration can be saved in the display module.	
	Data comparison function The device configuration saved in the display module can be compared to the current device configuration.	
	Data transfer function The transmitter configuration can be transmitted to another device using the display module.	

Operation with remote display and operating module FHX50

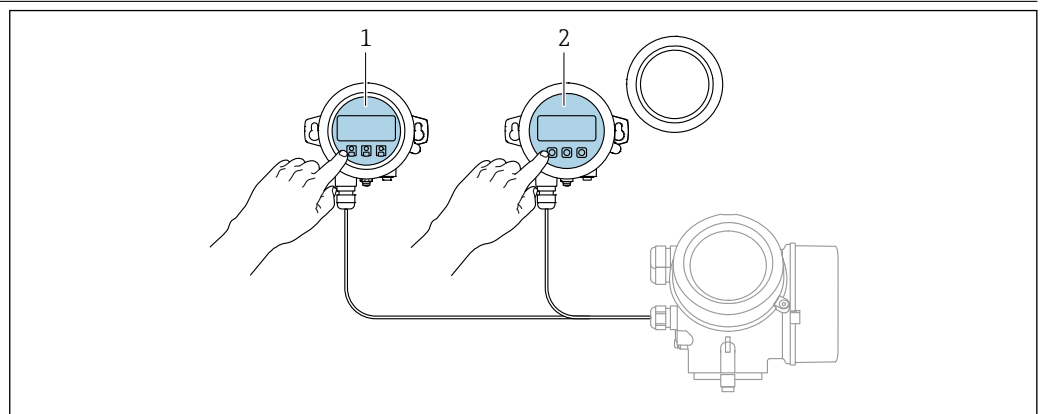

19 FHX50 operating options

- 1 Display and operating module SD03, optical keys; can be operated through the glass of the cover
- 2 Display and operating module SD02, push buttons; cover must be removed

Operation via Bluetooth® wireless technology

Requirements

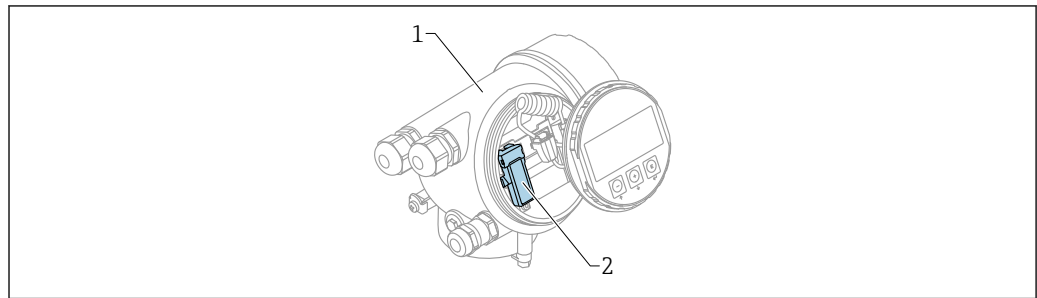

A0036790

☑ 20 Device with Bluetooth module

- 1 Electronics housing of the device
- 2 Bluetooth module

This operation option is only available for devices with Bluetooth module. There are the following options:

- The device has been ordered with a Bluetooth module:
Feature 610 "Accessory Mounted", option NF "Bluetooth"
- The Bluetooth module has been ordered as an accessory (ordering number: 71377355) and has been mounted. See Special Documentation SDO2252F.

Operation via SmartBlue (app)

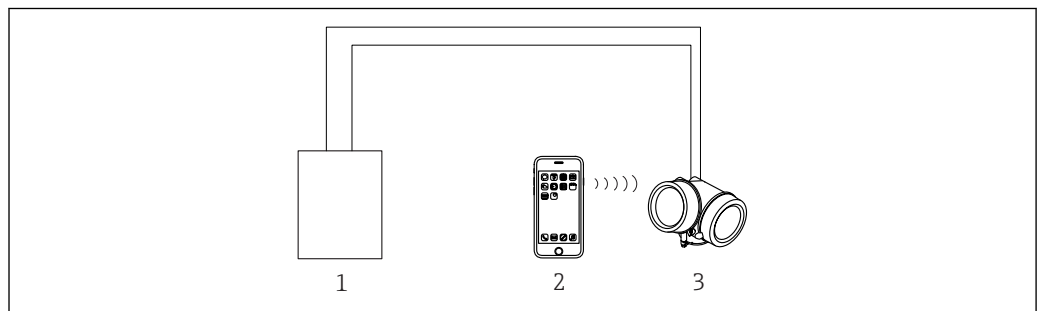

A0034939

☑ 21 Operation via SmartBlue (app)

- 1 Transmitter power supply unit
- 2 Smartphone / tablet with SmartBlue (app)
- 3 Transmitter with Bluetooth module

Remote operation

Via HART protocol

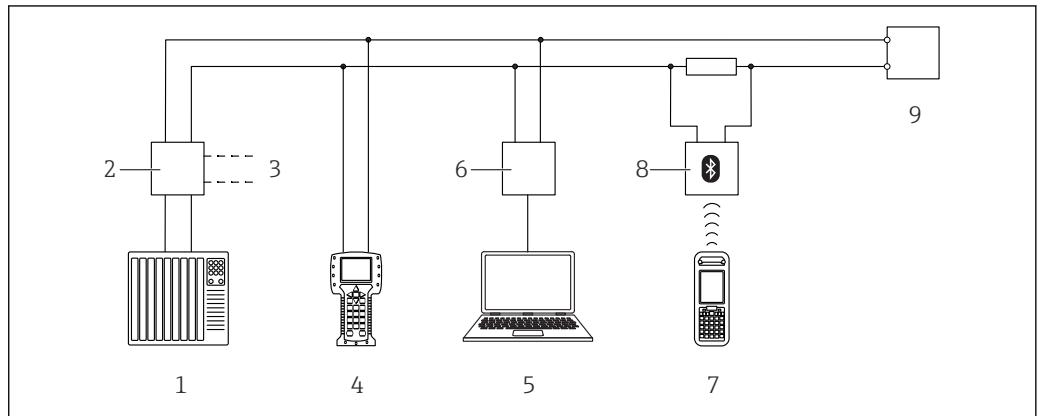

A0036169

22 Options for remote operation via HART protocol

- 1 PLC (Programmable Logic Controller)
- 2 Transmitter power supply unit, e.g. RN221N (with communication resistor)
- 3 Connection for Commubox FXA191, FXA195 and Field Communicator 375, 475
- 4 Field Communicator 475
- 5 Computer with operating tool (e.g. DeviceCare/FieldCare, AMS Device Manager, SIMATIC PDM)
- 6 Commubox FXA191 (RS232) or FXA195 (USB)
- 7 Field Xpert SFX350/SFX370
- 8 VIATOR Bluetooth modem with connecting cable
- 9 Transmitter

DeviceCare/FieldCare via service interface (CDI)

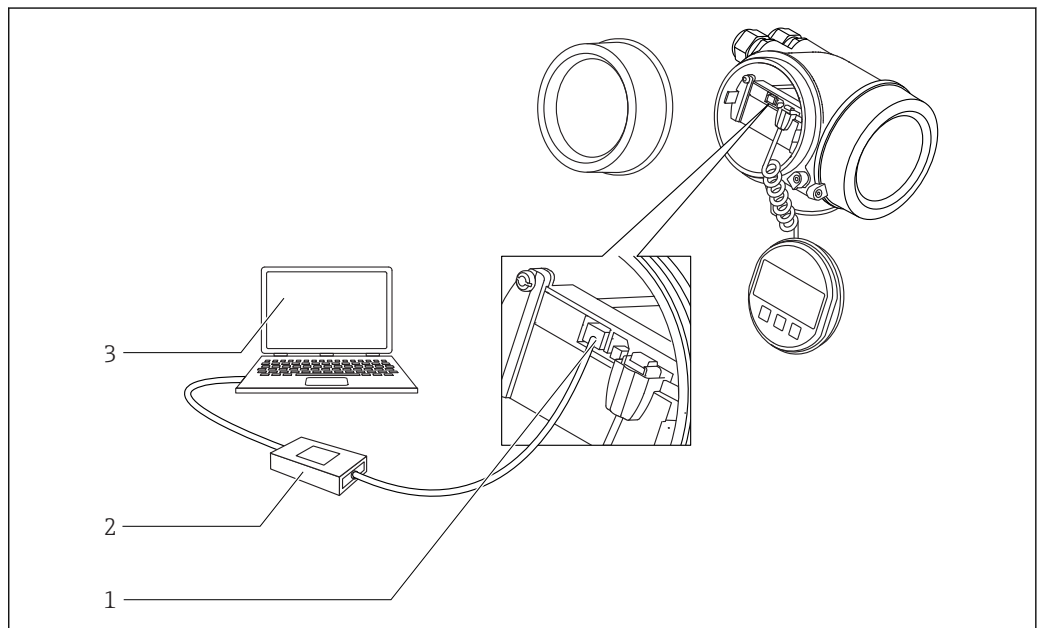

A0032466

23 DeviceCare/FieldCare via service interface (CDI)

- 1 Service interface (CDI) of the instrument (= Endress+Hauser Common Data Interface)
- 2 Commubox FXA291
- 3 Computer with DeviceCare/FieldCare operating tool

SupplyCare inventory management software

SupplyCare is a web-based operating program for coordinating the flow of material and information along the supply chain. SupplyCare provides a comprehensive overview of the levels of geographically distributed tanks and silos, for instance, providing complete transparency over the current inventory situation, regardless of time and location.

Based on the measuring and transmission technology installed onsite, the current inventory data are collected and sent to SupplyCare. Critical levels are clearly indicated and calculated forecasts provide additional security for material requirements planning.

The main functions of SupplyCare:

Inventory visualization

SupplyCare determines the inventory levels in tanks and silos at regular intervals. It displays current and historical inventory data and calculated forecasts of future demand. The overview page can be configured to suit the user's preferences.

Master data management

With SupplyCare you can create and manage the master data for locations, companies, tanks, products and users, as well as user authorization.

Report Configurator

The Report Configurator can be used to create personalized reports quickly and easily. The reports can be saved in a variety of formats, such as Excel, PDF, CSV and XML. The reports can be transmitted in many ways, such as by http, ftp or e-mail.

Event management

Events, such as when levels drop below the safety stock level or plan points, are indicated by the software. In addition, SupplyCare can also notify pre-defined users by e-mail.

Alarms

If technical problems occur, e.g. connection issues, alarms are triggered and alarm e-mails are sent to the System Administrator and the Local System Administrator.

Delivery planning

The integrated delivery planning function automatically generates an order proposal if a pre-set minimum inventory level is undershot. Scheduled deliveries and disposals are monitored continuously by SupplyCare. SupplyCare notifies the user if scheduled deliveries and disposals are not going to be met as planned.

Analysis

In the Analysis module, the most important indicators for the inflow and outflow of the individual tanks are calculated and displayed as data and charts. Key indicators of material management are automatically calculated and form the basis for optimizing the delivery and storage process.

Geographical visualization

All the tanks and the tank inventories are represented graphically on a map (based on Google Maps). The tanks and inventory situations can be filtered by tank group, product, supplier or location.

Multi-language support

The multi-language user interface supports 9 languages, thereby enabling global collaboration on a single platform. The language and settings are recognized automatically using the browser settings.

SupplyCare Enterprise

SupplyCare Enterprise runs by default as a service under Microsoft Windows on an application server in an Apache Tomcat environment. The operators and administrators operate the application via a Web browser from their workstations.

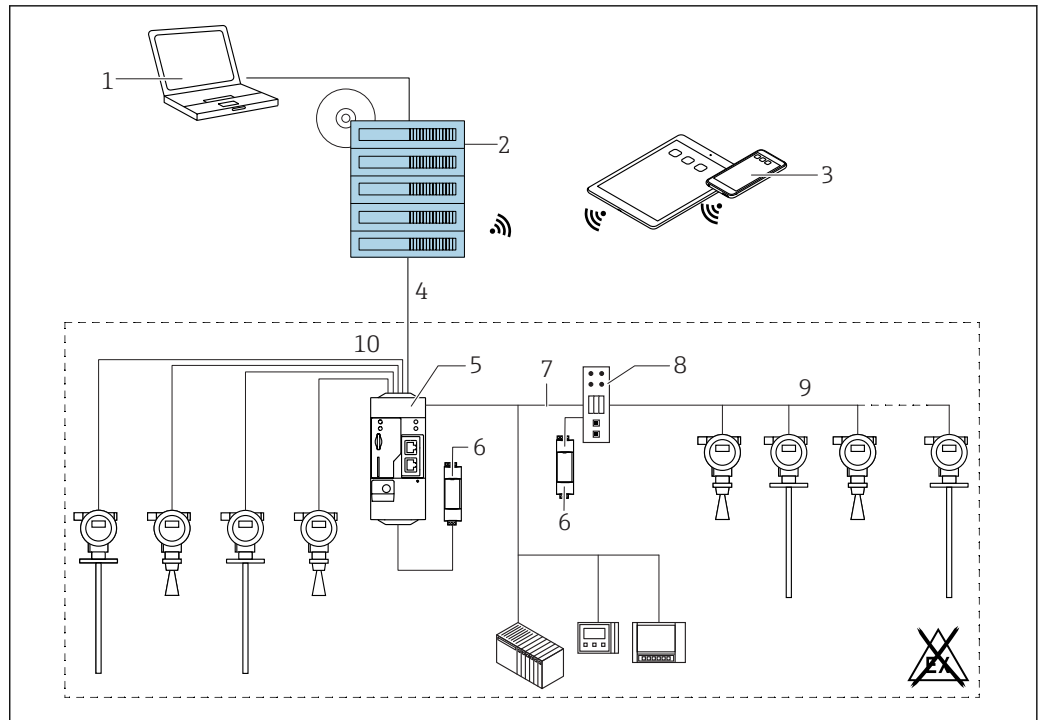

A0034288

24 Example of inventory management platform with SupplyCare Enterprise SCE30B

- 1 SupplyCare Enterprise (via Web browser)
- 2 SupplyCare Enterprise installation
- 3 SupplyCare Enterprise on mobile devices (via Web browser)
- 4 Ethernet/WLAN/UMTS
- 5 Fieldgate FXA42
- 6 Power supply 24 V DC
- 7 Modbus TCP via Ethernet as server/client
- 8 Converter from Modbus to HART Multidrop
- 9 HART Multidrop
- 10 4 x 4 to 20 mA analog input (2-wire/4-wire)

Cloud-based application: SupplyCare Hosting

SupplyCare Hosting is offered as a hosting service (software as a service). Here, the software is installed within the Endress+Hauser IT infrastructure and made available to the user in the Endress+Hauser portal.

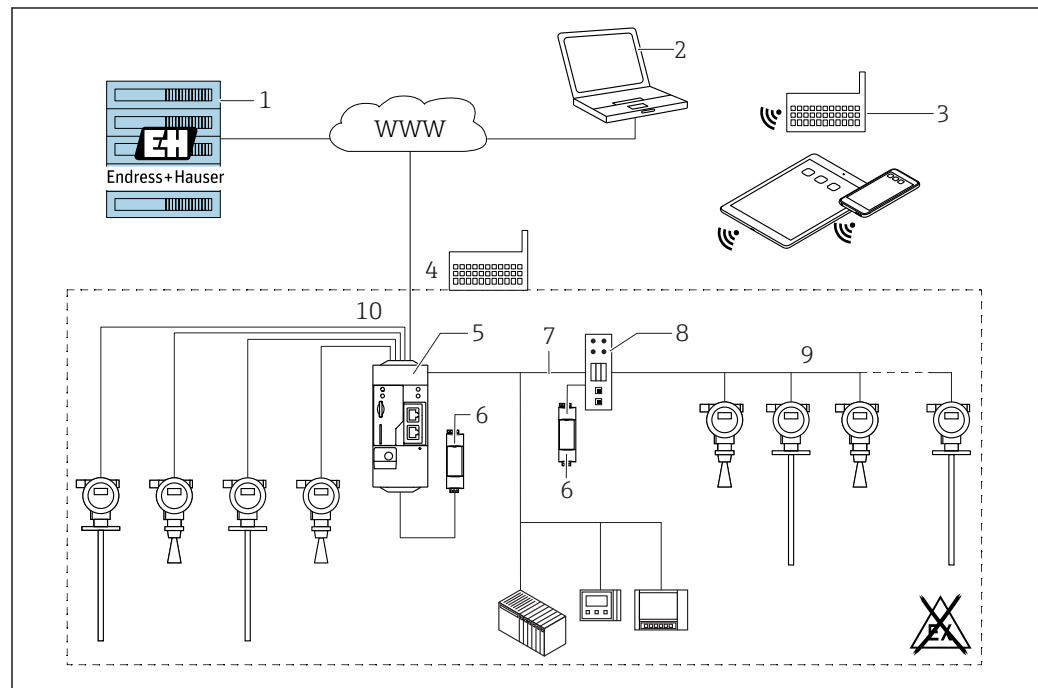

25 Example of inventory management platform with SupplyCare Hosting SCH30

- 1 SupplyCare Hosting installation in Endress+Hauser data center
- 2 PC workstation with Internet connection
- 3 Warehouse locations with Internet connection via 2G/3G with FXA42 or FXA30
- 4 Warehouse locations with Internet connection with FXA42
- 5 Fieldgate FXA42
- 6 Power supply 24 V DC
- 7 Modbus TCP via Ethernet as server/client
- 8 Converter from Modbus to HART Multidrop
- 9 HART Multidrop
- 10 4 x 4 to 20 mA analog input (2-wire/4-wire)

With SupplyCare Hosting, users do not need to make the initial software purchase or install and run the IT infrastructure needed. Endress+Hauser constantly update SupplyCare Hosting and enhance the capability of the software in conjunction with the customer. The hosted version of SupplyCare is thus always up-to-date and can be customized to meet different customer requirements. Other services are also offered in addition to the IT infrastructure and the software that is installed in a secure, redundant Endress+Hauser data center. These services include defined availability of the global Endress+Hauser Service and Support Organization and defined response times in a service event.

Certificates and approvals



Currently available certificates and approvals can be called up via the product configurator.

CE mark

The measuring system meets the legal requirements of the applicable EC guidelines. These are listed in the corresponding EC Declaration of Conformity together with the standards applied.

Endress+Hauser confirms successful testing of the device by affixing to it the CE mark.

RoHS

The measuring system complies with the substance restrictions of the Restriction on Hazardous Substances Directive 2011/65/EU (RoHS 2).

RCM-Tick marking

The supplied product or measuring system meets the ACMA (Australian Communications and Media Authority) requirements for network integrity, interoperability, performance characteristics as well as health and safety regulations. Here, especially the regulatory arrangements for electromagnetic compatibility are met. The products are labelled with the RCM- Tick marking on the name plate.



A0029561

Ex approval

- ATEX
- IECEx
- CSA
- FM
- NEPSI
- KC
- INMETRO
- JPN ⁵⁾
- EAC

Additional safety instructions must be followed for use in hazardous areas. Please refer to the separate "Safety Instructions" (XA) document included in the delivery. Reference to the applicable XA can be found on the nameplate.



For details on the available certificates and associated XAs: → 69

Dual seal according to ANSI/ISA 12.27.01

The devices have been designed according to ANSI/ISA 12.27.01 as dual seal devices, allowing the user to waive the use and save the cost of installing external secondary process seals in the conduit as required by the process sealing sections of ANSI/NFPA 70 (NEC) and CSA 22.1 (CEC) These instruments comply with the North-American installation practice and provide a very safe and cost-saving installation for pressurized applications with hazardous fluids.

Further information can be found in the Safety Instructions (XA) of the relevant devices.

Functional safety

Use for level monitoring (MIN, MAX, range) up to SIL 3 (homogeneous or diverse redundancy), independently evaluated by TÜV Rheinland in accordance with IEC 61508, refer to the "Functional Safety Manual" for information.

WHG

WHG approval

Pressure equipment with allowable pressure ≤ 200 bar (2 900 psi)

Pressure instruments with a flange and threaded boss that do not have a pressurized housing do not fall within the scope of the Pressure Equipment Directive, irrespective of the maximum allowable pressure.

Reasons:

According to Article 2, point 5 of EU Directive 2014/68/EU, pressure accessories are defined as "devices with an operational function and having pressure-bearing housings".

5) in preparation

If a pressure instrument does not have a pressure-bearing housing (no identifiable pressure chamber of its own), there is no pressure accessory present within the meaning of the Directive.

Radio standard EN 302729

The devices comply with the Level Probing Radar (LPR) radio standard EN 302729. The devices are approved for unrestricted use inside and outside closed containers in countries of the EU and the EFTA that have already implemented this standard.

The following countries are those that have currently implemented the directive:

Belgium, Bulgaria, Germany, Denmark, Estonia, France, Greece, UK, Ireland, Iceland, Italy, Liechtenstein, Lithuania, Latvia, Malta, The Netherlands, Norway, Austria, Poland, Portugal, Romania, Sweden, Switzerland, Slovakia, Spain, Czech Republic and Cyprus.

Implementation is still underway in all of the countries not listed.

Please note the following for operation of the devices outside of closed vessels:

1. Installation must be carried out by properly trained, expert staff.
2. The device antenna must be installed in a fixed location pointing vertically downwards.
3. The installation site must be located at a distance of 4 km from the astronomy stations listed below or otherwise approval must be provided by the relevant authority. If the device is installed at a distance of 4 to 40 km from one of the listed stations, it must not be installed at a height of more than 15 m (49 ft) above the ground.

Astronomy stations

Country	Name of the station	Latitude	Longitude
Germany	Effelsberg	50°31'32" North	06°53'00" East
Finland	Metsähovi	60°13'04" North	24°23'37" East
	Tuorla	60°24'56" North	24°26'31" East
France	Plateau de Bure	44°38'01" North	05°54'26" East
	Floirac	44°50'10" North	00°31'37" West
Great Britain	Cambridge	52°09'59" North	00°02'20" East
	Damhall	53°09'22" North	02°32'03" West
	Jodrell Bank	53°14'10" North	02°18'26" West
	Knockin	52°47'24" North	02°59'45" West
	Pickmere	53°17'18" North	02°26'38" West
Italy	Medicina	44°31'14" North	11°38'49" East
	Noto	36°52'34" North	14°59'21" East
	Sardinia	39°29'50" North	09°14'40" East
Poland	Fort Skala Krakow	50°03'18" North	19°49'36" East
Russia	Dmitrov	56°26'00" North	37°27'00" East
	Kalyazin	57°13'22" North	37°54'01" East
	Pushchino	54°49'00" North	37°40'00" East
	Zelenchukskaya	43°49'53" North	41°35'32" East
Sweden	Onsala	57°23'45" North	11°55'35" East
Switzerland	Bleien	47°20'26" North	08°06'44" East
Spain	Yebes	40°31'27" North	03°05'22" West
	Robledo	40°25'38" North	04°14'57" West
Hungary	Penc	47°47'22" North	19°16'53" East



As a general rule, the requirements outlined in EN 302729 must be observed.

Radio standard EN 302372 The devices comply with the Tanks Level Probing Radar (TLPR) radio standard EN 302372 and are approved for use in closed containers. For installation, points a to f in Annex E of EN 302372 must be taken into consideration.

FCC This device complies with Part 15 of the FCC rules. Operation is subject to the following two conditions: (1) This device may not cause harmful interference, and (2) this device must accept any interference received, including interference that may cause undesired operation.

[Any] changes or modifications not expressly approved by the party responsible for compliance could void the user's authority to operate the equipment.

The devices are compliant with the FCC Code of Federal Regulations, CFR 47, Part 15, Sections 15.205, 15.207, 15.209.

In addition, the devices are compliant with Section 15.256 . For these LPR (Level Probe Radar) applications the devices must be professionally installed in a downward operating position. In addition, the devices are not allowed to be mounted in a zone of 4 km around RAS stations and within a radius of 40 km around RAS stations the maximum operation height of devices is 15 m (49 ft) above ground.

Industry Canada **Canada CNR-Gen Section 7.1.3**

This device complies with Industry Canada licence-exempt RSS standard(s). Operation is subject to the following two conditions: (1) This device may not interference, and (2) this device must accept any interference, including interference that may cause undesired operation of the device.

Le présent appareil est conforme aux CNR d'Industrie Canada applicables aux appareils radio exempts de licence. L'exploitation est autorisée aux deux conditions suivantes : (1) l'appareil ne doit pas produire de brouillage, et (2) l'utilisateur de l'appareil doit accepter tout brouillage radioélectrique subi, même si le brouillage est susceptible d'en compromettre le fonctionnement.

[Any] changes or modifications not expressly approved by the party responsible for compliance could void the user's authority to operate the equipment.

- The installation of the LPR/TLPR device shall be done by trained installers, in strict compliance with the manufacturer's instructions.
- The use of this device is on a "no-interference, no-protection" basis. That is, the user shall accept operations of high-powered radar in the same frequency band which may interfere with or damage this device. However, devices found to interfere with primary licensing operations will be required to be removed at the user's expense.
- This device shall be installed and operated in a completely enclosed container to prevent RF emissions, which can otherwise interfere with aeronautical navigation.
- The installer/user of this device shall ensure that it is at least 10 km from the Dominion Astrophysical Radio Observatory (DRAO) near Penticton, British Columbia. The coordinates of the DRAO are latitude 49°19'15" N and longitude 119°37'12" W. For devices not meeting this 10 km separation (e.g., those in the Okanagan Valley, British Columbia,) the installer/user must coordinate with, and obtain the written concurrence of, the Director of the DRAO before the equipment can be installed or operated. The Director of the DRAO may be contacted at 250-497-2300 (tel.) or 250-497-2355 (fax). (Alternatively, the Manager, Regulatory Standards Industry Canada, may be contacted.)

 The model FMR60 fulfills the requirements for use as LPR (Level Probe Radar).

CRN approval (Canadian pressure equipment directive)

- Selection in the product structure: Feature 590 "Additional Approval", option LD "CRN"
- This option can be selected if the device has a CRN approved process connection according to the following table:

Feature 100 in the product structure	Process connection
GGJ	Thread ISO228 G1-1/2, 316L
RGJ	Thread ANSI MNPT1-1/2, 316L
XJJ	UNI flange 3"/DN80/80, 316L, max 4bar abs / 58 psia, suitable for NPS " Cl.150 / DN80 PN16 / 10K 80

Feature 100 in the product structure	Process connection
XKJ	UNI flange 4"/DN100/100, 316L, max 4bar abs / 58 psia, suitable for NPS 4" Cl.150 / DN100 PN16 / 10K 100
XLJ	UNI flange 6"/DN150/150, 316L, max 4bar abs / 58 psia, suitable for NPS 6" Cl.150 / DN150 PN16 / 10K 150

-  For some process connections which are not listed in the product structure a CRN approval is available on request.
- CRN-approved devices bear the registration number CRN 0F19773.5C on the nameplate.

Test, certificate

Feature 580 "Test, certificate"	Description
JA	3.1 Material certificate, wetted metal parts, EN10204-3.1 inspection certificate



Test reports, declarations and inspection certificates are available in electronic format in the *W@M Device Viewer*:

Enter the serial number from nameplate (www.endress.com/deviceviewer)

This concerns the options for the following order codes:

- 550 "Calibration"
- 580 "Test, certificate"

Hard-copy product documentation

Hard-copy versions of the test reports, declarations and inspection certificates can also be order via order code 570 "Service", option I7 "Hard-copy product documentation". The documents are then supplied with the product.

Other standards and guidelines

- EN 60529
Degrees of protection provided by enclosures (IP code)
- EN 61010-1
Safety Requirements for Electrical Equipment for Measurement, Control and Laboratory Use
- IEC/EN 61326
"Emission in accordance with Class A requirements". Electromagnetic compatibility (EMC requirements).
- NAMUR NE 21
Electromagnetic compatibility (EMC) of industrial process and laboratory control equipment
- NAMUR NE 43
Standardization of the signal level for the breakdown information of digital transmitters with analog output signal.
- NAMUR NE 53
Software of field devices and signal-processing devices with digital electronics
- NAMUR NE 107
Status classification as per NE107
- NAMUR NE 131
Requirements for field devices for standard applications.
- IEC61508
Functional safety of safety-related electric/electronic/programmable electronic systems

Ordering information

Ordering information

Detailed ordering information is available from the following sources:

- In the Product Configurator on the Endress+Hauser website: www.endress.com -> Click "Corporate" -> Select your country -> Click "Products" -> Select the product using the filters and search field -> Open product page -> The "Configure" button to the right of the product image opens the Product Configurator.
- From your Endress+Hauser Sales Center: www.addresses.endress.com



Product Configurator - the tool for individual product configuration

- Up-to-the-minute configuration data
- Depending on the device: Direct input of measuring point-specific information such as measuring range or operating language
- Automatic verification of exclusion criteria
- Automatic creation of the order code and its breakdown in PDF or Excel output format
- Ability to order directly in the Endress+Hauser Online Shop

3-point linearity protocol

 The following points must be considered if option F3 (3-point linearity protocol) was selected in feature 550 ("Calibration").

The 3 points of the linearity protocol are defined as follows:

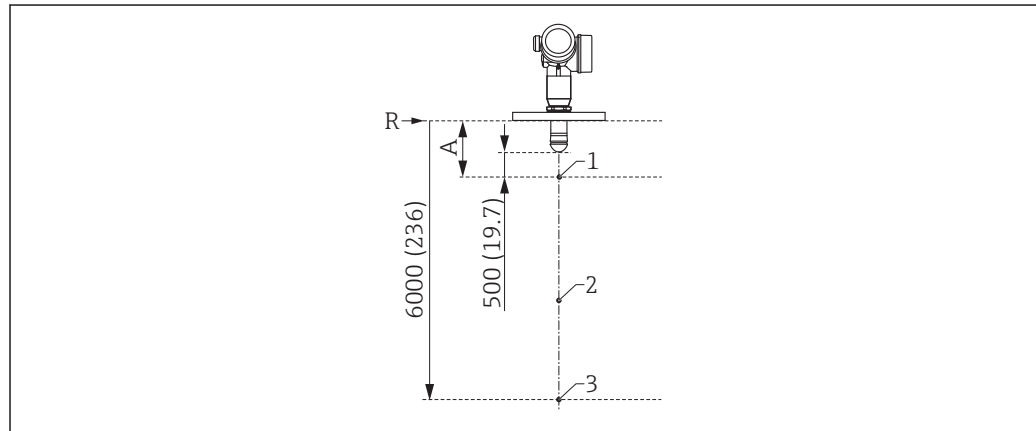

A0032642

 26 Points of the 3-point linearity protocol; engineering unit: mm (in)

A Distance from the reference point R to the first measuring point

R Reference point of measurement

1 First measuring point

2 Second measuring point (in the middle between the first and third measuring point)

3 Third measuring point

Measuring point	Position
1st measuring point	<ul style="list-style-type: none"> ■ At a distance A from the reference point ■ A = length of antenna + 500 mm (19.7 in) ■ Minimum distance: $A_{\min} = 1000$ mm (39.4 in)
2nd measuring point	In the middle between the 1st and 3rd measuring point
3rd measuring point	6 000 mm (236 in) below the reference point R

 The position of the measuring points can vary by ± 1 cm (± 0.04 in).

 The linearity check is performed under reference operating conditions.

5-point linearity protocol

i The following points must be considered if option F4 (5-point linearity protocol) was selected in feature 550 ("Calibration").

The 5 points of the linearity protocol are evenly distributed over the measuring range (0% - 100%). **Empty calibration (E)** and **Full calibration (F)** must be specified in order to define the measuring range⁶⁾.

The following restrictions must be considered when selecting E and F:

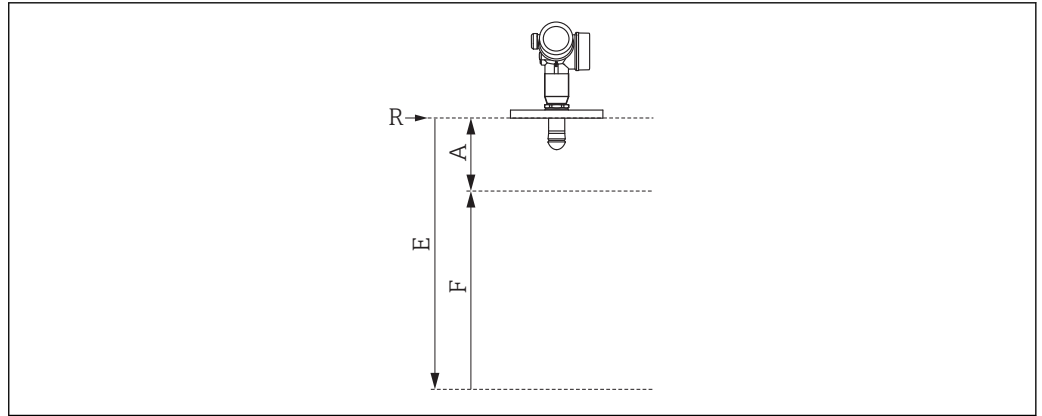

A0032643

Minimum distance between reference point R and 100% mark	Minimum span	Maximum value for "Empty calibration"
A ≥ length of antenna + 200 mm (8 in) Minimum value: 400 mm (16 in)	F ≥ 400 mm (16 in)	E ≤ 24 m (79 ft)

i The linearity check is performed under reference operating conditions.

i The selected values for **Empty calibration** and **Full calibration** are only used to create the linearity protocol. Afterwards, the values are reset to the default values specific for the antenna. If values other than the default values are required, they must be ordered as a customized parameterization → 58.

6) If (E) and (F) are not specified, antenna-dependent default values will be used instead.

Customer-specific configuration

If the option IJ: "Customized parameterization HART", IK "Customized parameterization PA" or IL "Customized parameterization FF" has been selected in feature 570 "Service", presettings that differ from the default settings can be selected for the following parameters:



Parameters	Communication protocol	Picklist / range of values
Setup → Unit of length	<ul style="list-style-type: none"> ■ HART ■ PA ■ FF 	<ul style="list-style-type: none"> ■ in ■ ft ■ mm ■ m
Setup → Empty calibration	<ul style="list-style-type: none"> ■ HART ■ PA ■ FF 	max. 70 m (230 ft)
Setup → Full calibration	<ul style="list-style-type: none"> ■ HART ■ PA ■ FF 	max. <70 m (230 ft)
Setup → Extended setup → Curr. output 1 or 2 → Damping	HART	0 to 999.9 s
Setup → Extended setup → Curr. output 1 or 2 → Failure mode	HART	<ul style="list-style-type: none"> ■ Min ■ Max ■ Last valid value
Expert → Comm. → HART config. → Burst mode	HART	<ul style="list-style-type: none"> ■ Off ■ On

Tagging (TAG)

Ordering feature	895: Marking
Option	Z1: Tagging (TAG), see additional spec.
Position of the measuring point marking	To be selected in the additional specifications: <ul style="list-style-type: none"> ■ Tag plate Stainless Steel ■ Self-adhesive paper label ■ Supplied label/plate ■ RFID TAG ■ RFID TAG + Tag plate Stainless Steel ■ RFID TAG + Self-adhesive paper label ■ RFID TAG + Supplied label/plate
Definition of the measuring point designation	To be defined in the additional specifications: 3 lines containing up to 18 characters each The measuring point designation appears on the selected label and/or the RFID TAG.
Designation in the Electronic Name Plate (ENP)	The first 32 characters of the measuring point designation
Designation on the display module	The first 12 characters of the measuring point designation

Services

The following services can be selected via the product structure in the Product Configurator ⁷⁾:

- PWIS-free (PWIS = paint-wetting impairment substances)
- Customized parameterization HART →  58
- Customized parameterization PA →  58
- Customized parameterization FF →  58
- W/o tooling DVD (FieldCare)
- Hard-copy product documentation

7) Feature 570 in the product structure

Application Packages

Heartbeat Diagnostics

Availability

Available in all device versions.

Function

- Continuous self-monitoring of the device.
- Diagnostic messages output to
 - the local display.
 - an asset management system (e.g. FieldCare/DeviceCare).
 - an automation system (e.g. PLC).

Advantages

- Device condition information is available immediately and processed in time.
- The status signals are classified in accordance with VDI/VDE 2650 and NAMUR recommendation NE 107 and contain information about the cause of the error and remedial action.

Detailed description

See Operating Instructions of the device (→  69); chapter "Diagnostics and trouble shooting"

Heartbeat Verification

Availability

Available for the following options of feature 540 "Application Package":

- EH: Heartbeat Verification + Monitoring
- EJ: Heartbeat Verification

Device functionality checked on demand

- Verification of the correct functioning of the measuring device within specifications.
- The verification result provides information about the condition of the device: **Passed** or **Failed**.
- The results are documented in a verification report.
- The automatically generated report supports the obligation to demonstrate compliance with internal and external regulations, laws and standards.
- Verification is possible without interrupting the process.

Advantages

- No onsite presence is required to use the function.
- The DTM⁸⁾ triggers verification in the device and interprets the results. No specific knowledge is required on the part of the user.
- The verification report can be used to prove quality measures to a third party.
- **Heartbeat Verification** can replace other maintenance tasks (e.g. periodic check) or extend the test intervals.

SIL/WHG-locked devices⁹⁾

- The **Heartbeat Verification** module contains a wizard for the proof test which must be performed at appropriate intervals for the following applications:
 - SIL (IEC61508/IEC61511)
 - WHG (German Water Resources Act)
- To perform a proof test, the device must be locked (SIL/WHG locking).
- The wizard can be used via FieldCare, DeviceCare or a DTM-based process control system.



In the case of SIL-locked and WHG-locked devices, it is **not** possible to perform verification without additional measures (e.g. by-passing of the output current) because the output current must be simulated (Increased safety mode) or the level must be approached manually (Expert mode) during subsequent re-locking (SIL/WHG locking).

Detailed description



SD01870F

8) DTM: Device Type Manager; controls device operation via DeviceCare, FieldCare or a DTM-based process control system.

9) Only relevant for devices with SIL or WHG approval: order code 590 ("Additional approval"), option LA ("SIL") or LC ("WHG").

Heartbeat Monitoring

Availability

Available for the following options of feature 540 "Application Package":
EH: Heartbeat Verification + Monitoring

Function

- In addition to the verification parameters, the corresponding parameter values are also logged.
- Existing measured variables, such as the echo amplitude, are used in the **Foam detection** and **Build-up detection** wizards.

"Foam detection" wizard

- The Heartbeat Monitoring module contains the **Foam detection** wizard.
- This wizard is used to configure automatic foam detection, which detects foam on the product surface on the basis of the reduced signal amplitude. Foam detection can be linked to a switch output in order to control a sprinkler system, for example, which dissolves the foam.
- This wizard can be used via FieldCare, DeviceCare or a DTM-based process control system.

"Build-up detection" wizard

- The Heartbeat Monitoring module contains the **Build-up detection** wizard.
- The wizard is used to configure automatic buildup detection, which detects the buildup of deposits on the antenna on the basis of the increased area of the coupling signal. Buildup detection can be linked to a switch output in order to control a compressed air system, for example, to clean the antenna.
- This wizard can be used via FieldCare, DeviceCare or a DTM-based process control system.

Advantages

- Early detection of changes (trends) to ensure plant availability and product quality.
- Use of information for the proactive planning of measures (e.g. cleaning/maintenance).
- Identification of undesirable process conditions as the basis to optimizing the facility and the processes.
- Automated control of measures to remove foam or buildup.



Detailed description



SD01870F

Accessories

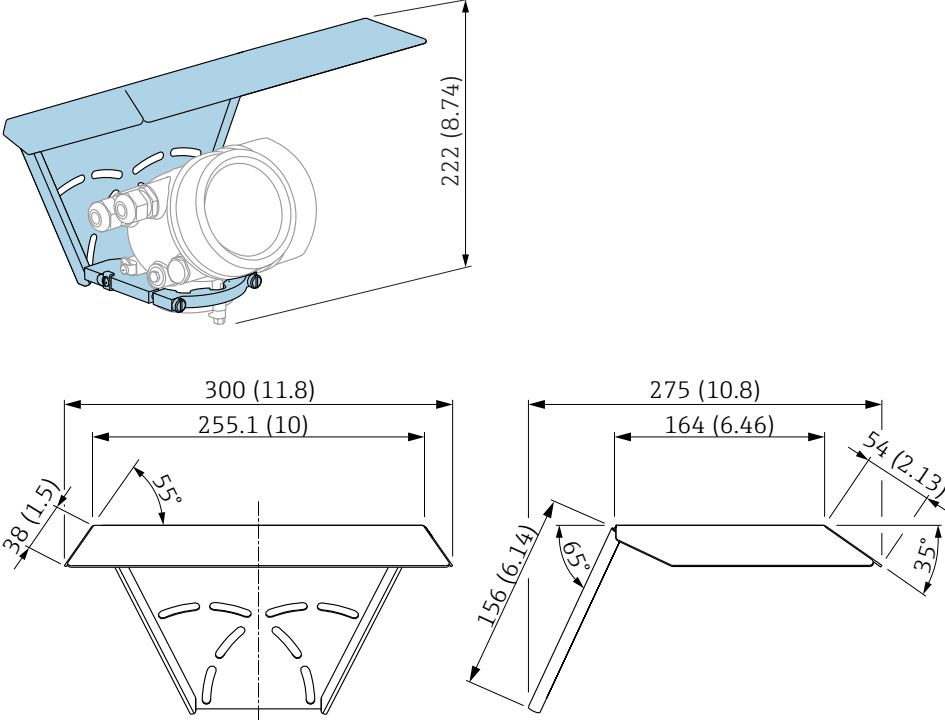
Device-specific accessories Weather protection cover

Accessory	Description
Weather protection cover	 <p data-bbox="1380 734 1436 750">A0015466</p> <p data-bbox="1380 1146 1436 1162">A0015472</p> <p data-bbox="327 1171 837 1198">  27 Weather protection cover; Dimensions: mm (in) </p> <p data-bbox="327 1227 1404 1310">  The weather protection cover can be ordered together with the device (product structure, feature 620 "Accessory Enclosed", option PB "Weather Protection Cover"). Alternatively, it can be separately ordered as an accessory; order code 71162242. </p>

Mounting bracket adjustable

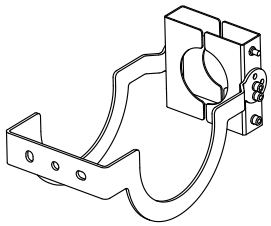
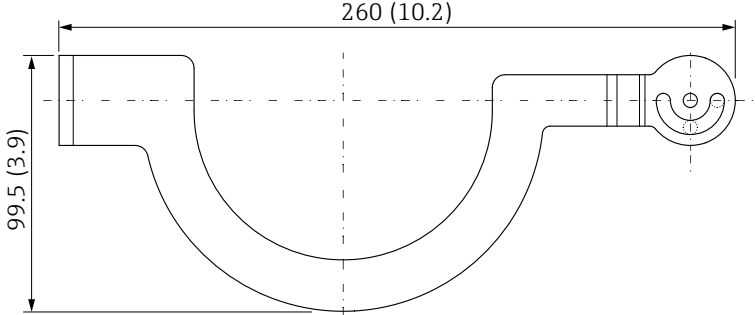
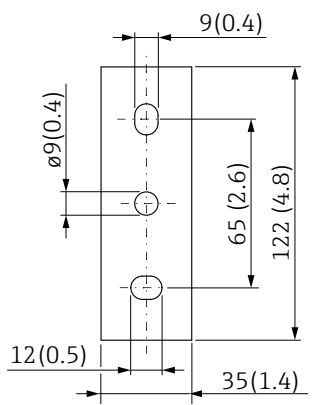
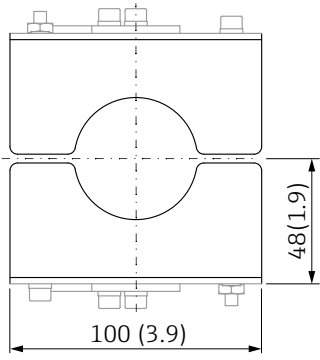
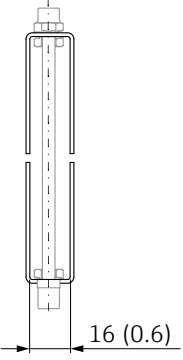
Accessories	Description
<p>Mounting bracket adjustable</p>	<div style="text-align: right; margin-bottom: 20px;">  </div> <div style="text-align: center; margin-bottom: 20px;">  </div> <div style="display: flex; justify-content: space-around; align-items: flex-start;"> <div style="text-align: center;">  </div> <div style="text-align: center;">  </div> <div style="text-align: center;">  </div> </div> <p>Material: 304 (1.4301)</p> <p>Suitable for housing¹⁾:</p> <ul style="list-style-type: none"> - A: GT19 dual compartment, plastic PBT - C: GT20 dual compartment, Alu, coated <p>Suitable for antenna²⁾:</p> <p>GA: Drip-off, PTFE DN50</p> <p>Suitable for process connection³⁾:</p> <ul style="list-style-type: none"> - GGJ: thread ISO228 G1-1/2, 316L - RGJ: thread ANSI MNPT1-1/2, 316L <p>Order number: 71336522</p> <p>i</p> <ul style="list-style-type: none"> ▪ There is no conductive connection between the mounting bracket and the transmitter housing. ▪ Risk of electrostatic charge. ▪ Integrate the mounting bracket in the local potential equalization system. ▪ Only to be fastened at stable materials (e.g. metal, brick, concrete) using suitable fastening material (to be supplied by customer).

A0032295

1) Feature 040 in the product structure
 2) Feature 070 in the product structure
 3) Feature 100 in the product structure

Remote display FHX50

Accessories	Description
Remote display FHX50	<div data-bbox="327 324 1204 750" style="text-align: center;"> </div> <p style="text-align: right; font-size: small;">A0019128</p> <ul style="list-style-type: none"> ■ Material: <ul style="list-style-type: none"> – Plastic PBT – 316L/1.4404 – Aluminum ■ Degree of protection: IP68 / NEMA 6P and IP66 / NEMA 4x ■ Suitable for display modules: <ul style="list-style-type: none"> – SD02 (push buttons) – SD03 (touch control) ■ Connecting cable: <ul style="list-style-type: none"> – Cable supplied with device up to 30 m (98 ft) – Standard cable supplied by customer up to 60 m (196 ft) ■ Ambient temperature range: –40 to 80 °C (–40 to 176 °F) ■ Ambient temperature range (option): –50 to 80 °C (–58 to 176 °F) ¹⁾ <p> i ■ If the remote display should be used, order the device version "Prepared for display FHX50" (feature 030, version L, M or N). For the FHX50, you must select option A: "Prepared for display FHX50" under feature 050 "Measuring device version". </p> <p> i ■ If the device version "Prepared for display FHX50" was not originally ordered and a FHX50 display is to be retrofitted, you must select version B "Not prepared for display FHX50" under feature 050: "Measuring device version" when ordering the FHX50. In this case, a retrofit kit for the device is supplied with the FHX50. The kit can be used to prepare the device so that the FHX50 can be used. </p> <p> i Use of the FHX50 may be restricted for transmitters with an approval. A device can only be retrofitted with the FHX50 if the option L, M or N ("Prepared for FHX50") is listed under <i>Basic specifications</i>, item 4 "Display, operation" in the Safety Instructions (XA) for the device. Also pay attention to the Safety Instructions (XA) of the FHX50. </p> <p> i Retrofitting is not possible on transmitters with: <ul style="list-style-type: none"> ■ An approval for use in areas with flammable dust (dust ignition-proof approval) ■ Ex nA type of protection </p> <p> i For details, see document SD01007F. </p>

1) This range is valid if option JN "Ambient temperature transmitter –50 °C (–58 °F)" has been selected in ordering feature 580 "Test, Certificate". If the temperature is permanently below –40 °C (–40 °F), failure rates may be increased.

Overvoltage protection

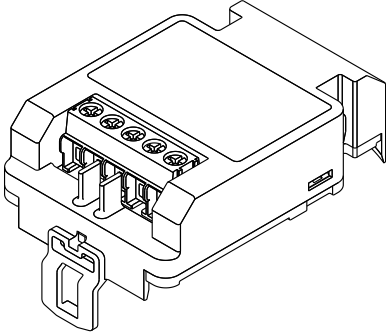
Accessory	Description
Overvoltage protection for 2-wire-devices OVP10 (1 channel) OVP20 (2 channel)	<div style="text-align: right; font-size: small;">A0021734</div>  <p>Technical data</p> <ul style="list-style-type: none"> ▪ Resistance per channel: $2 * 0.5 \Omega_{max}$ ▪ Threshold DC voltage: 400 to 700 V ▪ Threshold impulse voltage: < 800 V ▪ Capacitance at 1 MHz: < 1.5 pF ▪ Nominal arrest impulse voltage (8/20 μs): 10 kA ▪ Suited for wire cross-sections: 0.2 to 2.5 mm² (24 to 14 AWG) <p>i Ordering with device The overvoltage protection module is preferably ordered with the device. See product structure, feature 610 "Accessory mounted", option NA "Overvoltage protection". Separate ordering of the module is only necessary if a device is to be retrofitted with the overvoltage protection.</p> <p>i Order code for retrofitting</p> <ul style="list-style-type: none"> ▪ For 1-channel devices (feature 020, option A) OVP10: 71128617 ▪ For 2-channel devices (feature 020, option B, C, E or G) OVP20 : 71128619 <p>Housing lid for retrofitting In order to keep the necessary safety distances, the housing lid needs to be replaced if the device is retrofitted with the overvoltage protection. Depending on the housing type, the order code of the suitable lid is as follows:</p> <ul style="list-style-type: none"> ▪ GT18 housing: Lid 71185516 ▪ GT19 housing: Lid 71185518 ▪ GT20 housing: Lid 71185516 <p>i Restrictions for retrofitting Depending on the approval of the transmitter the usage of the OVP module may be restricted. A device may only be retrofitted with an OVP module if the option NA (overvoltage protection) is quoted under <i>Optional Specifications</i> in the Safety Instructions (XA) pertaining to the device.</p> <p>i For details refer to SD01090F.</p>

Gas-tight feedthrough

Accessories	Description
Gas-tight feedthrough	Chemically inert glass feedthrough; prevents gases from entering the electronics housing To order with the device: product structure, feature 610 "Accessory mounted", option NC "Gas-tight feedthrough"

Bluetooth module for HART devices

Accessory	Description
Bluetooth module	<div data-bbox="325 315 975 763" data-label="Image"> </div> <div data-bbox="1382 768 1437 784" data-label="Text">A0036493</div> <ul style="list-style-type: none"> ▪ Quick and easy commissioning via SmartBlue (app) ▪ No additional tools or adapters required ▪ Signal curve via SmartBlue (app) ▪ Encrypted single point-to-point data transmission (tested by Fraunhofer institute) and password protected communication via Bluetooth® wireless technology ▪ Range under reference conditions: > 10 m (33 ft) <p>i When using the Bluetooth module the minimum supply voltage increases by up to 3 V.</p> <p>i Ordering with device The Bluetooth module is preferably ordered with the device. See product structure, feature 610 "Accessory Mounted", option NF "Bluetooth". A separate order is only necessary in case of retrofitting.</p> <p>i Order code for retrofitting Bluetooth module (BT10): 71377355</p> <p>i Restrictions in case of retrofitting Depending on the approval of the transmitter, application of the Bluetooth module may be restricted. A device may only be retrofitted with a Bluetooth module if the option <i>NF</i> (Bluetooth) is listed in the associated Safety Instructions (XA) under <i>Optional specifications</i>.</p> <p>i For details refer to SD02252F.</p>

Communication-specific accessories

Accessory	Description
Commubox FXA195 HART	For intrinsically safe HART communication with FieldCare via the USB interface.  For details refer to Technical Information TI00404F

Accessory	Description
Commubox FXA291	Connects Endress+Hauser field devices with CDI interface (= Endress+Hauser Common Data Interface) to the USB interface of a computer. Order code: 51516983  For details refer to Technical Information TI00405C

Accessory	Description
HART Loop Converter HMX50	Evaluates the dynamic HART variables and converts them to analog current signals or limit values. Order code: 71063562  For details refer to Technical Information TI00429F and Operating Instructions BA00371F

Accessory	Description
WirelessHART Adapter SWA70	Connects field devices to a WirelessHART network. The WirelessHART adapter can be mounted directly at a HART device and is easily integrated into an existing HART network. It ensures safe data transmission and can be operated in parallel with other wireless networks.  For details refer to Operating Instructions BA00061S

Accessories	Description
Connect Sensor FXA30/FXA30B	Fully integrated, battery-powered gateway for simple applications with SupplyCare Hosting. Up to 4 field devices with 4 to 20 mA communication (FXA30/FXA30B), serial Modbus (FXA30B) or HART (FXA30B) can be connected. With its robust design and ability to run for years on the battery, it is ideal for remote monitoring in isolated locations. Version with LTE (USA, Canada and Mexico only) or 3G mobile transmission for worldwide communication.  For details, see "Technical Information" TI01356S and Operating Instructions BA01710S.

Accessories	Description
Fieldgate FXA42	Fieldgates enable communication between connected 4 to 20 mA, Modbus RS485 and Modbus TCP devices and SupplyCare Hosting or SupplyCare Enterprise. The signals are transmitted either via Ethernet TCP/IP, WLAN or mobile communications (UMTS). Advanced automation capabilities are available, such as an integrated Web-PLC, OpenVPN and other functions.  For details, see "Technical Information" TI01297S and Operating Instructions BA01778S.



Accessories	Description
SupplyCare Enterprise SCE30B	Inventory management software that visualizes levels, volumes, masses, temperatures, pressures, densities or other tank parameters. The parameters are recorded and transmitted by means of gateways of the type Fieldgate FXA42. This Web-based software is installed on a local server and can also be visualized and operated with mobile terminals such as a smartphone or tablet.  For details, see "Technical Information" TI01228S and Operating Instructions BA00055S

Accessories	Description
SupplyCare Hosting SCH30	<p>Inventory management software that visualizes levels, volumes, masses, temperatures, pressures, densities or other tank parameters. The parameters are recorded and transmitted by means of gateways of the type Fieldgate FXA42, FXA30 and FXA30B.</p> <p>SupplyCare Hosting is offered as a hosting service (Software as a Service, SaaS). In the Endress+Hauser portal, the user is provided with the data over the Internet.</p> <p> For details, see "Technical Information" TI01229S and Operating Instructions BA00050S.</p>



Accessory	Description
Field Xpert SFX350	<p>Field Xpert SFX350 is a mobile computer for commissioning and maintenance. It enables efficient device configuration and diagnostics for HART and FOUNDATION fieldbus devices in the non-Ex area.</p> <p> For details, see Operating Instructions BA01202S</p>

Accessory	Description
Field Xpert SFX370	<p>Field Xpert SFX370 is a mobile computer for commissioning and maintenance. It enables efficient device configuration and diagnostics for HART and FOUNDATION fieldbus devices in the non-Ex area and the Ex area.</p> <p> For details, see Operating Instructions BA01202S</p>

Service-specific accessories

Accessory	Description
DeviceCare SFE100	<p>Configuration tool for HART, PROFIBUS and FOUNDATION Fieldbus devices</p> <p> Technical Information TI01134S</p> <p> <ul style="list-style-type: none"> ▪ DeviceCare is available for download at www.software-products.endress.com. The download requires a registration in the Endress+Hauser software portal. ▪ Alternatively, a DeviceCare DVD can be ordered with the device. Product structure: Feature 570 "Service", Option IV "Tooling DVD (DeviceCare Setup)". </p>
FieldCare SFE500	<p>FDT-based Plant Asset Management tool. Helps to configure and maintain all field devices of your plant. By supplying status information it also supports the diagnosis of the devices.</p> <p> Technical Information TI00028S</p>

System components

Accessory	Description
Graphic Data Manager Memograph M	<p>The graphic data manager Memograph M provides information on all the relevant process variables. Measured values are recorded correctly, limit values are monitored and measuring points analyzed. The data are stored in the 256 MB internal memory and also on an SD card or USB stick.</p> <p> For details refer to Technical Information TI00133R and Operating Instructions BA00247R</p>
RN221N	<p>Active barrier with power supply for safe separation of 4 to 20 mA current circuits. Provides bi-directional HART transmission.</p> <p> For details refer to Technical Information TI00073R and Operating Instructions BA00202R</p>
RNS221	<p>Transmitter supply for 2-wire sensors or transmitters exclusively for non-Ex areas. Provides bi-directional communication using the HART communication sockets.</p> <p> For details refer to Technical Information TI00081R and Operating Instructions KA00110R</p>

Supplementary documentation



For an overview of the scope of the associated Technical Documentation, refer to the following:

- The *W@M Device Viewer*: enter the serial number from the nameplate (www.endress.com/deviceviewer)
- The *Endress+Hauser Operations App*: Enter the serial number from the nameplate or scan the 2-D matrix code (QR code) on the nameplate.



The following document types are available:

In the Download Area of the Endress+Hauser Internet site: www.endress.com → Downloads

Standard documentation

Micropilot FMR60

Correlation of documentations to the device:

Device	Power supply, output ¹⁾	Communication	Document type	Document code
FMR60	A, B, C, K, L	HART	Operating Instructions	BA01618F
			Brief Operating Instructions	KA01251F
			Description of Device Parameters	GP01101F

1) Feature 020 in the product structure

Safety Instructions (XA)

Depending on the approval, the following Safety Instructions (XA) are supplied with the device. They are an integral part of the Operating Instructions.



The nameplate indicates the Safety Instructions (XA) that are relevant to the device.

Feature 010	Approval	Feature 020 "Power Supply; Output"		
		A ¹⁾	B ²⁾	C ³⁾
BA	ATEX II 1G Ex ia IIC T6 Ga	XA01549F	XA01549F	XA01549F
BB	ATEX II 1/2G Ex ia IIC T6 Ga/Gb	XA01549F	XA01549F	XA01549F
BC	ATEX II 1/2G Ex ia/db [ia Ga] IIC T6 Ga/Gb	XA01552F	XA01552F	XA01552F
BG	ATEX II 3G Ex ec IIC T6 Gc	XA01551F	XA01551F	XA01551F
BH	ATEX II 3G Ex ic IIC T6 Gc	XA01551F	XA01551F	XA01551F
B2	ATEX II 1/2G Ex ia IIC T6 Ga/Gb, 1/2D Ex ia IIIC T85°C Da/Db	XA01555F	XA01555F	XA01555F
B3	ATEX II 1/2G Ex ia/db [ia Ga] IIC T6, Ga/Gb 1/2D Ex ta/tb IIIC T85°C Da/Db	XA01556F	XA01556F	XA01556F
B4	ATEX II 1/2G Ex ia IIC T6 Ga/Gb, Ex ia/db [ia Ga] IIC T6 Ga/Gb	XA01553F	XA01553F	XA01553F
CB	CSA IS Cl.I Div.1 Gr.A-D	XA01612F	XA01612F	XA01612F
CC	CSA XP Cl.I Div.1 Gr.A-D [Ex ia]	XA01613F	XA01613F	XA01613F
C2	CSA IS Cl.I,II,III Div.1 Gr.A-G, Ex ia, NI Cl.1 Div.2 [Ex ia]	XA01612F	XA01612F	XA01612F
C3	CSA XP Cl.I,II,III Div.1 Gr.A-G, Zn0/1, NI Cl.I Div.2 [Ex ia]	XA01613F	XA01613F	XA01613F
FA	FM IS Cl.I Div.1 Gr.A-D	XA01615F	XA01615F	XA01615F
FB	FM IS Cl.I,II,III Div.1 Gr.A-G, AEx ia, NI Cl.1 Div.2	XA01615F	XA01615F	XA01615F
FC	FM XP-IS Cl.I Div.1 Gr.A-D, AIS Cl.I Div.1 Gr.A-D	XA01616F	XA01616F	XA01616F
FD	FM XP-IS Cl.I Div.1 Gr.A-D, Zn0/1, DIP-IS Cl.II,III Div.1 Gr.E-G, NI Cl.I Div.2	XA01616F	XA01616F	XA01616F
GA	EAC 0Ex ia IIC T6...T3 Ga X	XA01617F	XA01617F	XA01617F
GB	EAC Ga/Gb Ex ia IIC T6...T3 X	XA01617F	XA01617F	XA01617F
GC	EAC Ga/Gb Ex ia/db [ia Ga] IIC T6...T3 X	XA01618F	XA01618F	XA01618F
IA	IEC Ex ia IIC T6 Ga	XA01549F	XA01549F	XA01549F
IB	IEC Ex ia IIC T6 Ga/Gb	XA01549F	XA01549F	XA01549F

Feature 010	Approval	Feature 020 "Power Supply; Output"		
		A ¹⁾	B ²⁾	C ³⁾
IC	IEC Ex ia/db [ia Ga] IIC T6 Ga/Gb	XA01552F	XA01552F	XA01552F
IG	IEC Ex ec IIC T6 Gc	XA01551F	XA01551F	XA01551F
IH	IEC Ex ic IIC T6 Gc	XA01551F	XA01551F	XA01551F
I2	IEC Ex ia IIC T6 Ga/Gb, Ex ia IIIC T85°C Da/Db	XA01555F	XA01555F	XA01555F
I3	IEC Ex ia/db [ia Ga] IIC T6 Ga/Gb, Ex ta/tb IIIC T85°C Da/Db	XA01556F	XA01556F	XA01556F
I4	IEC Ex ia IIC T6 Ga/Gb, Ex ia/db [ia Ga] IIC T6 Ga/Gb	XA01553F	XA01553F	XA01553F
JA	JPN Ex ia IIC T6 Ga	XA01631F ⁴⁾	XA01631F ⁴⁾	XA01631F ⁴⁾
JB	JPN Ex ia IIC T6 Ga/Gb	XA01631F ⁴⁾	XA01631F ⁴⁾	XA01631F ⁴⁾
JC	JPN Ex d [ia] IIC T6 Ga/Gb	XA01632F ⁴⁾	XA01632F ⁴⁾	XA01632F ⁴⁾
JG	JPN Ex nA IIC T6 Gc	XA01725F ⁴⁾	XA01725F ⁴⁾	XA01725F ⁴⁾
JH	JPN Ex ic IIC T6 Gc	XA01725F ⁴⁾	XA01725F ⁴⁾	XA01725F ⁴⁾
J2	JPN Ex ia IIC T6 Ga/Gb, JPN Ex ia IIIC T85°C Da/Db	XA01728F ⁴⁾	XA01728F ⁴⁾	XA01728F ⁴⁾
J3	JPN Ex d [ia] IIC T6 Ga/Gb, JPN Ex ta/tb IIIC T85°C Da/Db	XA01729F ⁴⁾	XA01729F ⁴⁾	XA01729F ⁴⁾
J4	JPN Ex ia IIC T6 Ga/Gb, JPN Ex d [ia] IIC T6 Ga/Gb	XA01726F ⁴⁾	XA01726F ⁴⁾	XA01726F ⁴⁾
KA	KC Ex ia IIC T6 Ga	XA01623F	XA01623F	XA01623F
KB	KC Ex ia IIC T6 Ga/Gb	XA01623F	XA01623F	XA01623F
KC	KC Ex ia/db [ia Ga] IIC T6 Ga/Gb	XA01624F	XA01624F	XA01624F
MA	INMETRO Ex ia IIC T6 Ga	XA01620F	XA01620F	XA01620F
MB	INMETRO Ex ia IIC T6 Ga/Gb	XA01620F	XA01620F	XA01620F
MC	INMETRO Ex ia/db [ia Ga] IIC T6 Ga/Gb	XA01622F	XA01622F	XA01622F
MG	INMETRO Ex ec IIC T6 Gc	XA01621F	XA01621F	XA01621F
MH	INMETRO Ex ic IIC T6 Gc	XA01621F	XA01621F	XA01621F
NA	NEPSI Ex ia IIC T6 Ga	XA01625F	XA01625F	XA01625F
NB	NEPSI Ex ia IIC T6 Ga/Gb	XA01625F	XA01625F	XA01625F
NC	NEPSI Ex ia/d [ia Ga] IIC T6 Ga/Gb	XA01627F	XA01627F	XA01627F
NG	NEPSI Ex nA IIC T6 Gc	XA01626F	XA01626F	XA01626F
NH	NEPSI Ex ic IIC T6 Gc	XA01626F	XA01626F	XA01626F
N2	NEPSI Ex ia IIC T6 Ga/Gb, NEPSI Ex iaD 20/21 T85	XA01629F	XA01629F	XA01629F
N3	NEPSI Ex ia/d [ia Ga] IIC T6 Ga/Gb, NEPSI Ex tD A20/A21 IP6X T85°C	XA01630F	XA01630F	XA01630F
8A	FM/CSA IS+XP-IS Cl.I,II,III Div.1 Gr.A-G, AIS Cl.I,II,III Div.1 Gr.A-G	XA01612F XA01615F XA01616F	XA01612F XA01615F XA01616F	XA01612F XA01615F XA01616F
* 4)				

- 1) 2-wire; 4-20mA HART
2) 2-wire; 4-20mA HART, switch output
3) 2-wire; 4-20mA HART, 4-20mA
4) in preparation



www.addresses.endress.com
