

Technical Information

Micropilot FMR53, FMR54

Free space radar

Level measurement in liquids



Application

- Continuous, non-contact level measurement of liquids, pastes and slurries
- Rod antenna (FMR53); horn or planar antenna (FMR54)
- Maximum measuring range: 20 m (66 ft);
for FMR54 with planar antenna in stilling well: 38 m (125 ft)
- Process temperature: -196 to +400 °C (-321 to +752 °F)
- Process pressure: -1 to +160 bar (-14.5 to +2 320 psi)
- Accuracy: ± 6 mm
- International explosion protection certificates; WHG; marine approvals
- Linearity protocol (3-point, 5-point)

Your benefits

- Reliable measurement even for changing product and process conditions
- HistoROM data management for easy commissioning, maintenance and diagnostics
- Highest reliability due to Multi-Echo Tracking
- SIL2 according to IEC 61508, SIL3 in case of homogeneous or heterogeneous redundancy
- Seamless integration into control or asset management systems
- Intuitive user interface in national languages
- *Bluetooth*® wireless technology for commissioning, operation and maintenance via free iOS / Android app SmartBlue
- Easy proof test for SIL and WHG
- Heartbeat Technology™

Table of contents





Wichtige Hinweise zum Dokument	4	Climate class	59
Symbols	4	Altitude according to IEC61010-1 Ed.3	60
Terms and abbreviations	6	Degree of protection	60
Registered trademarks	7	Vibration resistance	60
		Cleaning the antenna	60
Function and system design	8	Electromagnetic compatibility (EMC)	60
Measuring principle	8		
		Process	61
Input	10	Process temperature, Process pressure	61
Measured variable	10	Dielectric constant	63
Measuring range	10		
Operating frequency	13	Mechanical construction	64
Transmitting power	13	Dimensions	64
		Weight	71
Output	14	Materials: GT18 housing (stainless steel, corrosion-resistant)	72
Output signal	14	Materials: GT19 housing (plastic)	73
Signal on alarm	15	Materials: GT20 housing (die-cast aluminum, powder-coated)	74
Linearization	15	Materials: Antenna and process connection	75
Galvanic isolation	15	Materials: Weather protection cover	78
Protocol-specific data	15		
		Operability	79
Power supply	20	Operating concept	79
Terminal assignment	20	Local operation	80
Device plug connectors	28	Operation with remote display and operating module	
Supply voltage	29	FHX50	80
Power consumption	31	Operation via Bluetooth® wireless technology	81
Current consumption	31	Remote operation	82
Power supply failure	32	Integration in tank gauging system	85
Potential equalization	32	SupplyCare inventory management software	86
Terminals	32		
Cable entries	32	Certificates and approvals	89
Cable specification	32	CE mark	89
Overvoltage protection	33	RoHS	89
		RCM-Tick marking	89
Performance characteristics	34	Ex approval	89
Reference operating conditions	34	Dual seal according to ANSI/ISA 12.27.01	89
Maximum measured error	34	Functional safety	89
Measured value resolution	34	WHG	89
Reaction time	34	Sanitary compatibility	89
Influence of ambient temperature	34	NACE MR 0175 / ISO 15156	89
Influence of gas layer	34	NACE MR 0103	90
Gas phase compensation with external pressure sensor (PROFIBUS PA, FOUNDATION Fieldbus)	35	Pressure equipment with allowable pressure ≤ 200 bar (2 900 psi)	90
		Marine certificate	90
Installation	36	Radio standard EN302372-1/2	90
Installation conditions	36	FCC / Industry Canada	90
Measuring conditions	39	Japanese radio approval	90
Mounting cladded flanges	40	CRN approval	90
Installation in vessel (free space)	41	Track record	91
Installation in stilling well	44	Test, Certificate	92
Installation in bypass	47	Hard-copy product documentation	92
Container with heat insulation	49	Other standards and guidelines	93
		Ordering information	94
Environment	50	Ordering information	94
Ambient temperature range	50	3-point linearity protocol	95
Ambient temperature limits	50		
Storage temperature	59		

5-point linearity protocol	96
Customized parametrization	97
Tagging (TAG)	97
Services	97
Application Packages	98
Heartbeat Diagnostics	98
Heartbeat Verification	99
Heartbeat Monitoring	100
Accessories	101
Device-specific accessories	101
Communication-specific accessories	106
Service-specific accessories	107
System components	107
Documentation	108
Standard documentation	108
Supplementary documentation	108
Safety Instructions (XA)	108





Wichtige Hinweise zum Dokument

Symbols









Safety symbols

Symbol	Meaning
	DANGER! This symbol alerts you to a dangerous situation. Failure to avoid this situation will result in serious or fatal injury.
	WARNING! This symbol alerts you to a dangerous situation. Failure to avoid this situation can result in serious or fatal injury.
	CAUTION! This symbol alerts you to a dangerous situation. Failure to avoid this situation can result in minor or medium injury.
	NOTE! This symbol contains information on procedures and other facts which do not result in personal injury.



Electrical symbols

Symbol	Meaning
	Direct current
	Alternating current
	Direct current and alternating current
	Ground connection A grounded terminal which, as far as the operator is concerned, is grounded via a grounding system.
	Protective Earth (PE) A terminal which must be connected to ground prior to establishing any other connections. The ground terminals are situated inside and outside the device: <ul style="list-style-type: none"> ▪ Inner ground terminal: Connects the protective earth to the mains supply. ▪ Outer ground terminal: Connects the device to the plant grounding system.



Symbols for certain types of information

Symbol	Meaning
	Permitted Procedures, processes or actions that are permitted.
	Preferred Procedures, processes or actions that are preferred.
	Forbidden Procedures, processes or actions that are forbidden.
	Tip Indicates additional information.
	Reference to documentation.
	Reference to page.
	Reference to graphic.
	Visual inspection.

Symbols in graphics

Symbol	Meaning
1, 2, 3 ...	Item numbers
	Series of steps
A, B, C, ...	Views
A-A, B-B, C-C, ...	Sections
	Hazardous area Indicates a hazardous area.
	Safe area (non-hazardous area) Indicates the non-hazardous area.

Symbols at the device

Symbol	Meaning
	Safety instructions Observe the safety instructions contained in the associated Operating Instructions.
	Temperature resistance of the connection cables Specifies the minimum value of the temperature resistance of the connection cables.

Terms and abbreviations

Term/abbreviation	Explanation
BA	Document type "Operating Instructions"
KA	Document type "Brief Operating Instructions"
TI	Document type "Technical Information"
SD	Document type "Special Documentation"
XA	Document type "Safety Instructions"
PN	Nominal pressure
MWP	Maximum Working Pressure The MWP can also be found on the nameplate.
ToF	Time of Flight
FieldCare	Scalable software tool for device configuration and integrated plant asset management solutions
DeviceCare	Universal configuration software for Endress+Hauser HART, PROFIBUS, FOUNDATION Fieldbus and Ethernet field devices
DTM	Device Type Manager
DD	Device Description for HART communication protocol
ϵ_r (DC value)	Relative dielectric constant
Operating tool	The term "operating tool" is used in place of the following operating software: <ul style="list-style-type: none"> ▪ FieldCare / DeviceCare, for operation via HART communication and PC ▪ SmartBlue (app), for operation using an Android or iOS smartphone or tablet.
BD	Blocking Distance; no signals are analyzed within the BD.
PLC	Programmable Logic Controller
CDI	Common Data Interface
PFS	Pulse Frequency Status (Switching output)
MBP	Manchester Bus Powered
PDU	Protocol Data Unit

Registered trademarks

HART®

Registered trademark of the FieldComm Group, Austin, USA

PROFIBUS®

Registered trademark of the PROFIBUS User Organization, Karlsruhe, Germany

FOUNDATION™ Fieldbus

Registered trademark of the FieldComm Group, Austin, Texas, USA

Bluetooth®

The Bluetooth® word mark and logos are registered trademarks owned by the Bluetooth SIG, Inc. and any use of such marks by Endress+Hauser is under license. Other trademarks and trade names are those of their respective owners.

Apple®

Apple, the Apple logo, iPhone, and iPod touch are trademarks of Apple Inc., registered in the U.S. and other countries. App Store is a service mark of Apple Inc.

Android®

Android, Google Play and the Google Play logo are trademarks of Google Inc.

KALREZ®, VITON®

Registered trademark of DuPont Performance Elastomers L.L.C., Wilmington, USA

TEFLON®

Registered trademark of E.I. DuPont de Nemours & Co., Wilmington, USA

TRI CLAMP®

Registered trademark of Alfa Laval Inc., Kenosha, USA

Function and system design

Measuring principle

The Micropilot is a "downward-looking" measuring system, operating based on the time-of-flight method (ToF). It measures the distance from the reference point (process connection) to the product surface. Radar impulses are emitted by an antenna, reflected off the product surface and received again by the radar system.

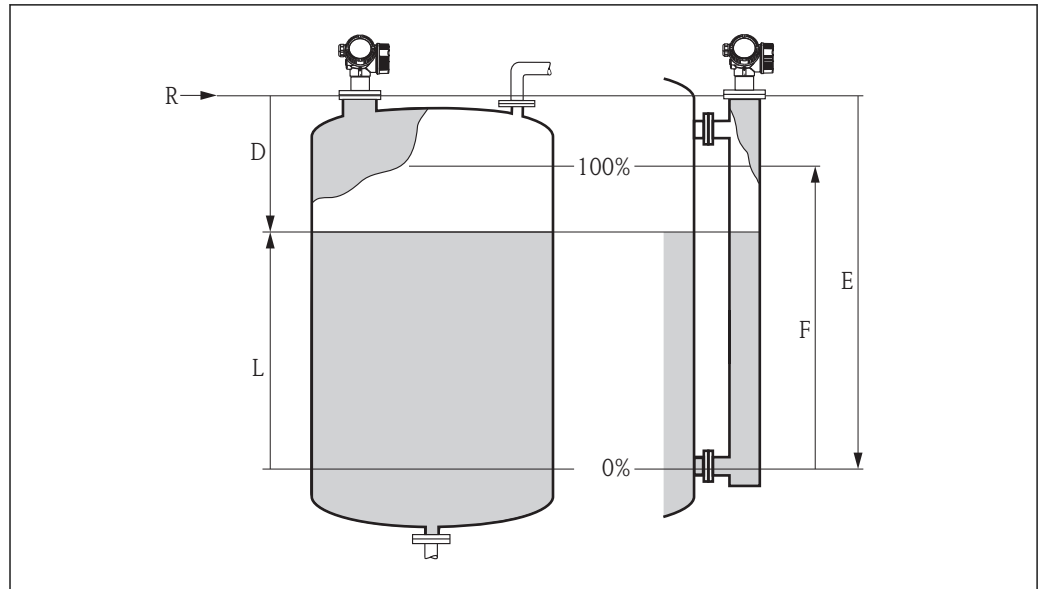

A0017871

1 Setup parameters of the Micropilot

- R* Reference point of the measurement (lower edge of the flange or threaded connection)
E Empty calibration (= zero)
F Full calibration (= span)
D Measured distance
L Level ($L = E - D$)

Input

The reflected radar impulses are received by the antenna and transmitted into the electronics. A microprocessor evaluates the signal and identifies the level echo caused by the reflection of the radar impulse at the product surface. The unambiguous signal identification is accomplished by the PulseMaster® eXact software together with the Multi-echo tracking algorithms, based on many years of experience with time-of-flight technology.

The distance D to the product surface is proportional to the time of flight t of the impulse:

$$D = c \cdot t / 2,$$

with c being the speed of light.

Based on the known empty distance E , the level L is calculated:

$$L = E - D$$

The reference point R of the measurement is located at the process connection. For details see the dimensional drawing:

- FMR53: → 65
- FMR54: → 68

The Micropilot is equipped with functions to suppress interference echoes. The user can activate these functions. Together with the multi-echo tracking algorithms they ensure that interference echoes (i.e. from edges and weld seams) are not interpreted as level echo.

Output

The Micropilot is commissioned by entering an empty distance "E" (=zero), a full distance "F" (=span) and application parameters which automatically adapt the instrument to the process conditions. For models with a current output, the factory adjustment for zero point "E" and span "F" is 4 mA and 20 mA. For digital outputs and the display module, the factory adjustment for zero point "E" and span "F" is 0 % and 100 %.

A linearization with max. 32 points, based on a table entered either manually or semi-automatically, can be activated locally or remotely. This function provides a measurement in engineering units and a linear output signal for spheres, horizontal cylindrical tanks and vessels with conical outlet.

Life cycle of the product

Engineering

- Universal measuring principle
- Measurement unaffected by medium properties
- Hardware and software developed according to SIL IEC 61508

Procurement

- Endress+Hauser being the world market leader in level measurement guarantees asset protection
- Worldwide support and service

Installation

- Special tools are not required
- Reverse polarity protection
- Modern, detachable terminals
- Main electronics protected by a separate connection compartment

Commissioning

- Fast, menu-guided commissioning in only a few steps on site or from the control room
- Plain text display in national languages reduces the risk of error or confusion
- Direct local access of all parameters
- Short instruction manual at the device

Operation

- Multi-echo tracking: Reliable measurement through self-learning echo-search algorithms taking into account the short-term and long-term history in order to check the found echoes for plausibility and to suppress interference echoes.
- Diagnostics in accordance with NAMUR NE107

Maintenance

- HistoROM: Data backup for instrument settings and measured values
- Exact instrument and process diagnosis to assist fast decisions with clear details concerning remedies
- Intuitive, menu-guided operating concept in national languages saves costs for training, maintenance and operation
- Cover of the electronics compartment can be opened in hazardous areas

Retirement

- Order code translation for subsequent models
- RoHS-conforming (Restriction of certain Hazardous Substances), unleaded soldering of electronic components
- Environmentally sound recycling concept

Input

Measured variable

The measured variable is the distance between the reference point and the product surface.

The level is calculated from this distance, taking into account the empty distance "E" entered by the user.

If required, the level can be converted into other variables (volume, mass) by means of a linearization (up to 32 points).

Measuring range

Maximum measuring range

Device	Maximum measuring range
FMR53	20 m (66 ft)
FMR54 - horn antenna	20 m (66 ft)
FMR54 - planar antenna in stilling well	38 m (125 ft)

Usable measuring range

The usable measuring range depends on the size of the antenna, the reflectivity of the medium, the mounting location and eventual interference reflections.

The following tables describe the groups of media as well as the achievable measuring range as a function of application and media group. If the dielectric constant of a medium is unknown, it is recommended to assume media group B to ensure a reliable measurement.

Media groups

Media groups	DC (ϵ_r)	Example
A	1.4 to 1.9	non-conducting liquids, e.g. liquefied gas ¹⁾
B	1.9 to 4	non-conducting liquids, e.g. benzene, oil, toluene, ...
C	4 to 10	e.g. concentrated acids, organic solvents, esters, aniline, alcohol, acetone, ...
D	> 10	conducting liquids, e.g. aqueous solutions, dilute acids and alkalis

1) Treat Ammonia NH₃ as a medium of group A.



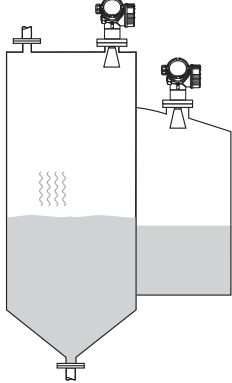
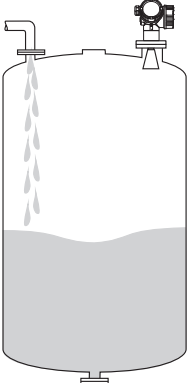
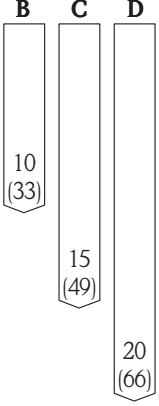
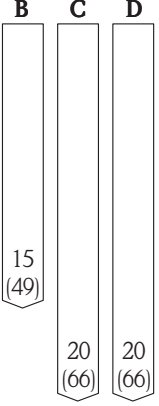
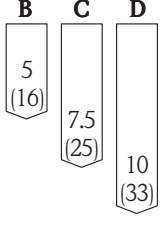
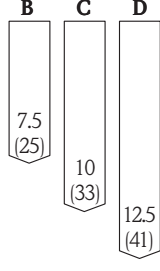

For dielectric constants (DC values) of many media commonly used in various industries refer to:

- the Endress+Hauser DC manual (CP01076F)
- the Endress+Hauser "DC Values App" (available for Android and iOS)

Device	Storage tank		Buffer tank	
	 <p style="text-align: right; font-size: small;">A0018833</p> <p>Calm product surface (e.g. intermittent filling, filling from bottom, immersion tubes)</p>		 <p style="text-align: right; font-size: small;">A0018835</p> <p>Moving surfaces (e.g. continuous filling, from above, mixing jets)</p>	
	Antenna type and size		Antenna type and size	
FMR53	Rod 390 mm (15 in) Rod 540 mm (21 in)	-	Rod 390 mm (15 in) Rod 540 mm (21 in)	-
FMR54 ¹⁾	Horn 150 mm (6 in)	Horn 200 mm (8 in) Horn 250 mm (10 in)	Horn 150 mm (6 in)	Horn 200 mm (8 in) Horn 250 mm (10 in)
	 <p style="text-align: right; font-size: x-small;">A0018844</p>	 <p style="text-align: right; font-size: x-small;">A0018845</p>	 <p style="text-align: right; font-size: x-small;">A0018846</p>	 <p style="text-align: right; font-size: x-small;">A0018847</p>
Measuring range [m (ft)]				

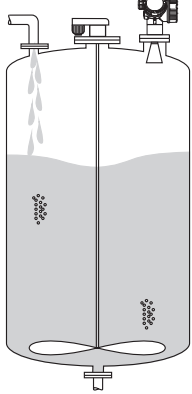
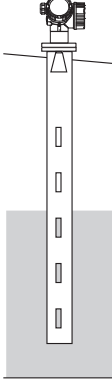
1) FMR54 with the antenna version BC (80mm/3") and BD: (100mm/4") should not be mounted directly in the tank. They are only suited for bypasses or stilling wells.

Device	Process tank with agitator		Stilling well		Bypass
	 <p data-bbox="667 696 719 712">A0018837</p> <p data-bbox="233 741 703 790">Turbulent surface (e.g. filling from above, agitators, baffles)</p>		 <p data-bbox="1150 680 1203 696">A0018839</p>		 <p data-bbox="1382 651 1437 667">A0018840</p>
	<p data-bbox="459 813 475 831">A</p> <p data-bbox="363 837 571 864">Antenna type and size</p>		<p data-bbox="979 808 1187 835">Antenna type and size</p>		
FMR53	Rod 390 mm (15 in) Rod 540 mm (21 in)	-	-	-	-
FMR54	Horn 150 mm (6 in)	Horn 200 mm (8 in) Horn 250 mm (10 in)	Horn 80 to 250 mm (3 to 10 in)	Planar 150 to 300 mm (6 to 12 in)	Horn 80 to 250 mm (3 to 10 in)
	<p data-bbox="276 1048 427 1227"> B 4 (13) C 6 (20) D 8 (26) </p> <p data-bbox="432 1234 488 1249">A0018848</p>	<p data-bbox="531 1048 687 1261"> B 6 (20) C 8 (26) D 10 (33) </p> <p data-bbox="667 1267 722 1283">A0018850</p>	<p data-bbox="788 1048 898 1070">A, B, C, D</p> <p data-bbox="820 1070 863 1451">20 (66)</p> <p data-bbox="898 1458 954 1473">A0018851</p>	<p data-bbox="1027 1048 1137 1070">A, B, C, D</p> <p data-bbox="1059 1720 1102 1787">38 (125)</p> <p data-bbox="1150 1794 1206 1809">A0018854</p>	<p data-bbox="1299 1048 1353 1070">C, D</p> <p data-bbox="1299 1384 1342 1451">20 (66)</p> <p data-bbox="1382 1458 1437 1473">A0018852</p>
<p data-bbox="708 1827 943 1854">Measuring range [m (ft)]</p>					

Operating frequency

C-band (~ 6 GHz)

Up to 8 Micropilot transmitters can be installed in the same tank because the transmitter pulses are statistically coded.

Transmitting power

Distance	Average energy density in beam direction
1 m (3.3 ft)	< 12 nW/cm ²
5 m (16 ft)	< 0.4 nW/cm ²

Output

Output signal

HART

Signal coding	FSK ± 0.5 mA over current signal
Data transmission rate	1200 Bit/s
Galvanic isolation	Yes

Bluetooth® wireless technology

Device version	Ordering feature 610 "Accessory mounted", option NF "Bluetooth"
Operation / configuration	By the <i>SmartBlue</i> app.
Range under reference conditions	> 10 m (33 ft)
Encryption	Encrypted communication and password encryption prevent incorrect operation by unauthorized persons.

PROFIBUS PA

Signal coding	Manchester Bus Powered (MBP)
Data transmission rate	31.25 kBit/s, voltage mode
Galvanic isolation	Yes

FOUNDATION Fieldbus

Signal coding	Manchester Bus Powered (MBP)
Data transmission rate	31.25 kBit/s, voltage mode
Galvanic isolation	Yes

Switch output

 For HART devices, the switch output is available as an option. See product structure, feature 20: "Power Supply, Output", option B: "2-wire; 4-20mA HART, switch output"

Devices with PROFIBUS PA and FOUNDATION Fieldbus always have a switch output.

Switch output	
Function	Open collector switching output
Switching behavior	Binary (conductive or non-conductive), switches when the programmable switch point is reached
Failure mode	non-conductive
Electrical connection values	$U = 16 \text{ to } 35 \text{ V}_{\text{DC}}$, $I = 0 \text{ to } 40 \text{ mA}$
Internal resistance	$R_i < 880 \Omega$ The voltage drop at this internal resistance has to be taken into account on planning the configuration. For example, the resulting voltage at a connected relay must be sufficient to switch the relay.
Insulation voltage	floating, Insulation voltage $1350 \text{ V}_{\text{DC}}$ to power supply and $500 \text{ V}_{\text{AC}}$ to ground
Switch point	freely programmable, separately for switch-on and switch-off point
Switching delay	freely programmable from 0 to 100 s, separately for switch-on and switch-off point
Number of switching cycles	corresponds to the measuring cycle
Signal source device variables	<ul style="list-style-type: none"> ▪ Level linearized ▪ Distance ▪ Terminal voltage ▪ Electronic temperature ▪ Relative echo amplitude ▪ Diagnostic values, Advanced diagnostics
Number of switching cycles	unlimited

Signal on alarm

Depending on the interface, failure information is displayed as follows:

- Current output (for HART devices)
 - Failsafe mode selectable (in accordance with NAMUR Recommendation NE 43):
Minimum alarm: 3.6 mA
Maximum alarm (= factory setting): 22 mA
 - Failsafe mode with user-selectable value: 3.59 to 22.5 mA
- Local display
 - Status signal (in accordance with NAMUR Recommendation NE 107)
 - Plain text display
- Operating tool via digital communication (HART, PROFIBUS PA, FOUNDATION Fieldbus) or service interface (CDI)
 - Status signal (in accordance with NAMUR Recommendation NE 107)
 - Plain text display

Linearization

The linearization function of the device allows the conversion of the measured value into any unit of length or volume. Linearization tables for calculating the volume in cylindrical tanks are pre-programmed. Other linearization tables of up to 32 value pairs can be entered manually or semi-automatically.

Galvanic isolation

All circuits for the outputs are galvanically isolated from each other.

Protocol-specific data

HART

Manufacturer ID	17 (0x11)
Device type ID	0x1128
HART specification	7.0
Device description files (DTM, DD)	Information and files under: <ul style="list-style-type: none"> ▪ www.endress.com ▪ www.fieldcommgroup.org
HART load	min. 250 Ω

HART device variables	<p>The measured values can be freely assigned to the device variables.</p> <p>Measured values for PV (primary variable)</p> <ul style="list-style-type: none"> ▪ Level linearized ▪ Distance ▪ Electronic temperature ▪ Relative echo amplitude ▪ Area of incoupling ▪ Analog output adv. diagnostics 1 ▪ Analog output adv. diagnostics 2 <p>Measured values for SV, TV, FV (second, third and fourth variable)</p> <ul style="list-style-type: none"> ▪ Level linearized ▪ Distance ▪ Electronic temperature ▪ Terminal voltage ▪ Relative echo amplitude ▪ Absolute echo amplitude ▪ Area of incoupling ▪ Analog output adv. diagnostics 1 ▪ Analog output adv. diagnostics 2
Supported functions	<ul style="list-style-type: none"> ▪ Burst mode ▪ Additional transmitter status

Wireless HART data

Minimum start-up voltage	16 V
Start-up current	3.6 mA
Start-up time	65 s
Minimum operating voltage	14.0 V
Multidrop current	4.0 mA
Set-up time	15 s

PROFIBUS PA

Manufacturer ID	17 (0x11)
Ident number	0x1559
Profile version	3.02
GSD file	Information and files under:
GSD file version	<ul style="list-style-type: none"> ▪ www.endress.com ▪ www.profibus.org
Output values	<p>Analog Input:</p> <ul style="list-style-type: none"> ▪ Level linearized ▪ Distance ▪ Terminal voltage ▪ Electronic temperature ▪ Absolute echo amplitude ▪ Relative echo amplitude ▪ Analog output adv. diagnostics 1 ▪ Analog output adv. diagnostics 2 <p>Digital Input:</p> <ul style="list-style-type: none"> ▪ Digital output AD 1 ▪ Digital output AD 2 ▪ Switch output

Input values	<p>Analog Output:</p> <ul style="list-style-type: none"> ▪ Analog value from PLC (for sensor block external pressure to compensate gas phase effects) ▪ Analog value from PLC to be indicated on the display <p>Digital Output:</p> <ul style="list-style-type: none"> ▪ Extended diagnostic block ▪ Level limiter ▪ Sensor block measurement on ▪ Sensor block save history on ▪ Status output
Supported functions	<ul style="list-style-type: none"> ▪ Identification & Maintenance Einfachste Geräteidentifizierung seitens des Leitsystems und des Typenschildes ▪ Automatic Ident Number Adoption GSD compatibility mode with respect to the preceding product Micropilot M FMR2xx ▪ Physical Layer Diagnostics Installation check of the PROFIBUS segment and the Micropilot FMR5x via the terminal voltage and telegram surveillance. ▪ PROFIBUS Up-/Download Up to 10 times faster writing and reading of parameters via PROFIBUS up-/download ▪ Condensed Status Simple and self-explanatory diagnostic information by categorization of occurring diagnostic messages.

FOUNDATION Fieldbus

Manufacturer ID	0x452B48
Device type	0x1028
Device Revision	0x01
DD Revision	Information and files can be found:
CFF Revision	<ul style="list-style-type: none"> ▪ www.endress.com ▪ www.fieldcommgroup.org
Device Tester Version (ITK Version)	6.0.1
ITK Test Campaign Number	IT085300
Link Master (LAS) capable	yes
Link Master / Basic Device selectable	yes; default: Basic Device
Node address	Default: 247 (0xF7)
Features supported	<p>Following methods are supported:</p> <ul style="list-style-type: none"> ▪ Restart ▪ ENP Restart ▪ Setup ▪ Linearization ▪ Self Check
Virtual Communication Relationships (VCRs)	
Number of VCRs	44
Number of Link Objects in VFD	50
Permanent entries	1
Client VCRs	0
Server VCRs	10
Source VCRs	43
Sink VCRs	0
Subscriber VCRs	43
Publisher VCRs	43
Device Link Capabilities	
Slot time	4

Min. inter PDU delay	8
Max. response delay	20

Transducer Blocks

Block	Content	Output values
Setup Transducer Block	Contains all parameters for a standard commissioning procedure	<ul style="list-style-type: none"> ■ Level or volume ¹⁾ (Channel 1) ■ Distance (Channel 2)
Advanced Setup Transducer Block	Contains all parameters for a more detailed configuration of the device	no output values
Display Transducer Block	Contains all parameters for the configuration of the display module	no output values
Diagnostic Transducer Block	Contains diagnostic information	no output values
Advanced Diagnostic Transducer Block	Contains parameters for the Advanced Diagnostic	no output values
Expert Configuration Transducer Block	Contains parameters which require detailed knowledge of the functionalities of the device	no output values
Expert Information Transducer Block	Contains information about the state of the device	no output values
Service Sensor Transducer Block	Contains parameters which can only be operated by Endress+Hauser service personnel	no output values
Service Information Transducer Block	Contains information on the state of device which is relevant for service operations	no output values
Data Transfer Transducer Block	Contains parameters which allow to backup the device configuration in the display module and to restore it into the device. Access to these parameters is restricted to the Endress+Hauser service.	no output values

1) depending on the configuration of the block

Function Blocks

Block	Content	Number of permanent blocks	Number of instantiable blocks	Execution time	Functionality
Resource Block	The Resource Block contains all the data that uniquely identifies the field device. It is an electronic version of a nameplate of the device.	1	0	-	enhanced
Analog Input Block	The AI block takes the manufacturer's input data, selected by channel number, and makes it available to other function blocks at its output.	2	3	25 ms	enhanced
Discrete Input Block	The DI block takes a discrete input value (e.g. indication of an level limit), and makes it available to other function blocks at its output.	1	2	20 ms	standard
Mutiple Analog Output Block	This block is used to transfer analog data from the bus into the device	1	0	20 ms	standard
Mutiple Discrete Output Block	This block is used to transfer discrete data from the bus to the device.	1	0	20 ms	standard

Block	Content	Number of permanent blocks	Number of instantiable blocks	Execution time	Functionality
PID Block	The PID block serves as proportional-integral-derivative controller and is used almost universally to do closed-loop-control in the field including cascade and feedforward.	1	1	25 ms	standard
Arithmetic Block	This block is designed to permit simple use of popular measurement math functions. The user does not have to know how to write equations. The math algorithm is selected by name, chosen by the user for the function to be done.	1	1	25 ms	standard
Signal Characterizer Block	The signal characterizer block has two sections, each with an output that is a non-linear function of the respective input. The non-linear function is determined by a single look-up table with 21 arbitrary x-y pairs.	1	1	25 ms	standard
Input Selector Block	The input selector block provides selection of up to four inputs and generates an output based on the configured action. This block normally receives its inputs from AI blocks. The block performs maximum, minimum, middle, average and 'first good' signal selection.	1	1	25 ms	standard
Integrator Block	The Integrator Function Block integrates a variable as a function of the time or accumulates the counts from a Pulse Input block. The block may be used as a totalizer that counts up until reset or as a batch totalizer that has a setpoint, where the integrated or accumulated value is compared to pre-trip and trip settings, generating discrete signals when these settings are reached.	1	1	25 ms	standard
Analog Alarm Block		1	1	25 ms	standard

 Up to 20 blocks can be instantiated in the device altogether, including the blocks already instantiated on delivery.

Power supply

Terminal assignment

Terminal assignment 2-wire: 4-20 mA HART

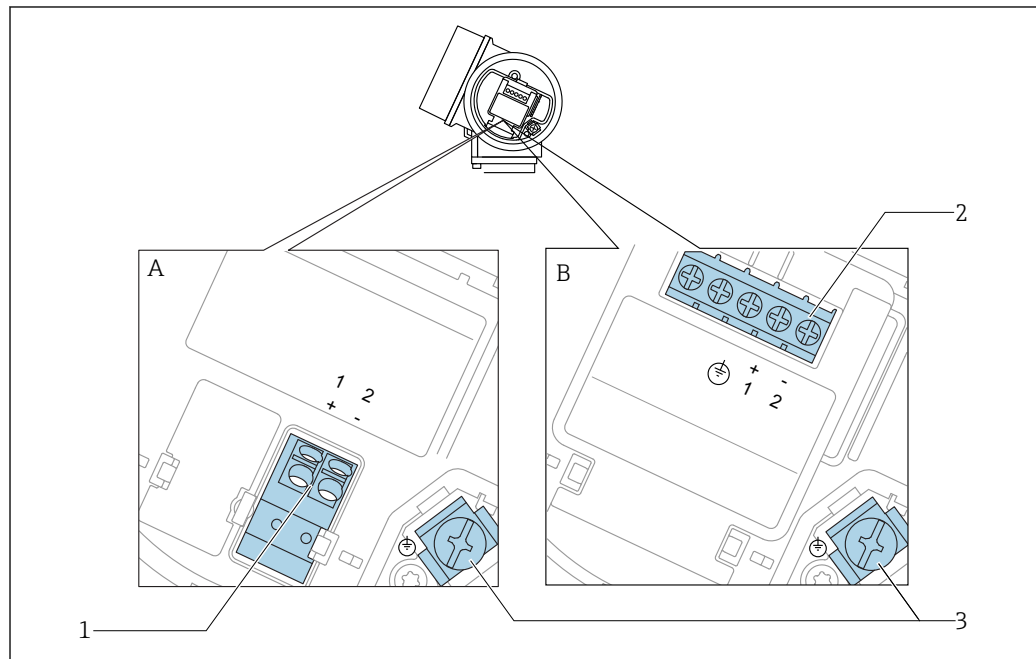

2 Terminal assignment 2-wire: 4-20 mA HART

- A Without integrated overvoltage protection
 B With integrated overvoltage protection
 1 Connection 4-20 mA HART passive: terminals 1 and 2, without integrated overvoltage protection
 2 Connection 4-20 mA HART passive: terminals 1 and 2, with integrated overvoltage protection
 3 Terminal for cable screen

Block diagram 2-wire: 4-20 mA HART

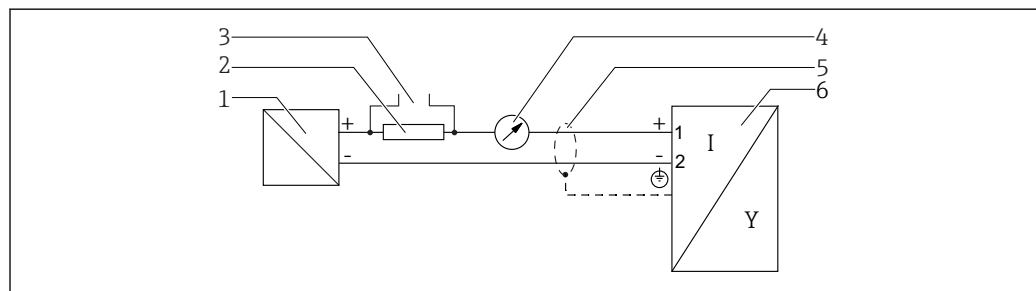

3 Block diagram 2-wire: 4-20 mA HART

- 1 Active barrier with power supply (e.g. RN221N); observe terminal voltage
 2 HART communication resistor ($\geq 250 \Omega$); observe maximum load
 3 Connection for Commubox FXA195 or FieldXpert SFX350/SFX370 (via VIATOR Bluetooth modem)
 4 Analog display device; observe maximum load
 5 Cable screen; observe cable specification
 6 Measuring device

Terminal assignment 2-wire: 4-20 mA HART, switch output

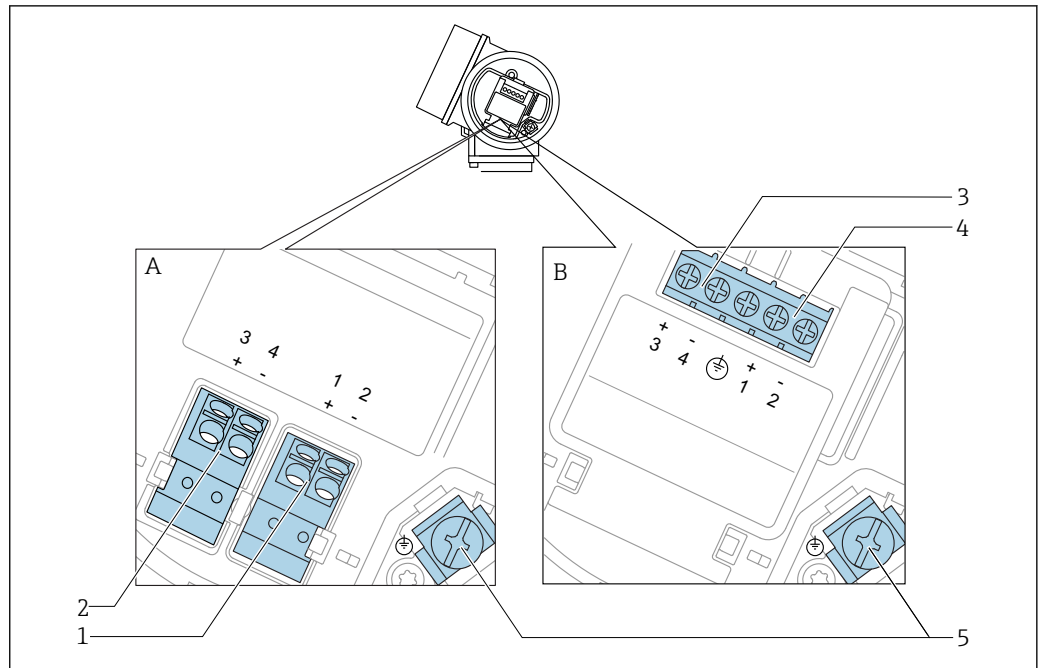

A0036500

4 Terminal assignment 2-wire: 4-20 mA HART, switch output

A Without integrated overvoltage protection

B With integrated overvoltage protection

1 Connection 4-20 mA HART passive: terminals 1 and 2, without integrated overvoltage protection

2 Connection switch output (Open Collector): terminals 3 and 4, without integrated overvoltage protection

3 Connection switch output (Open Collector): terminals 3 and 4, with integrated overvoltage protection

4 Connection 4-20 mA HART passive: terminals 1 and 2, with integrated overvoltage protection

5 Terminal for cable screen

Block diagram 2-wire: 4-20 mA HART, switch output

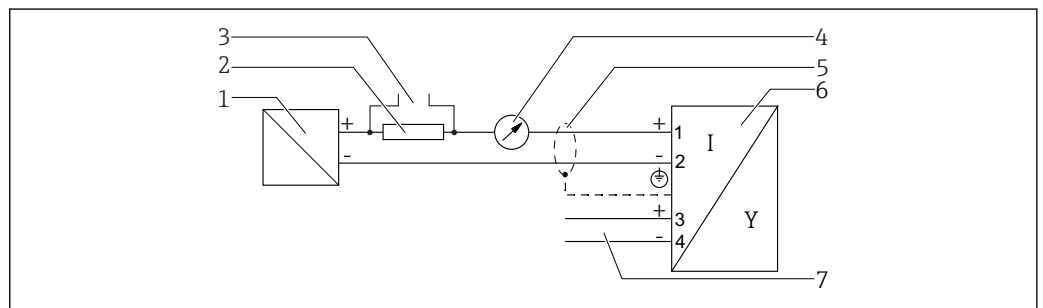

A0036501

5 Block diagram 2-wire: 4-20 mA HART, switch output

1 Active barrier with power supply (e.g. RN221N); observe terminal voltage

2 HART communication resistor ($\geq 250 \Omega$); observe maximum load

3 Connection for Commubox FXA195 or FieldXpert SFX350/SFX370 (via VIATOR Bluetooth modem)

4 Analog display device; observe maximum load

5 Cable screen; observe cable specification

6 Measuring device

7 Switch output (Open Collector)

Terminal assignment 2-wire: 4-20 mA HART, 4-20 mA

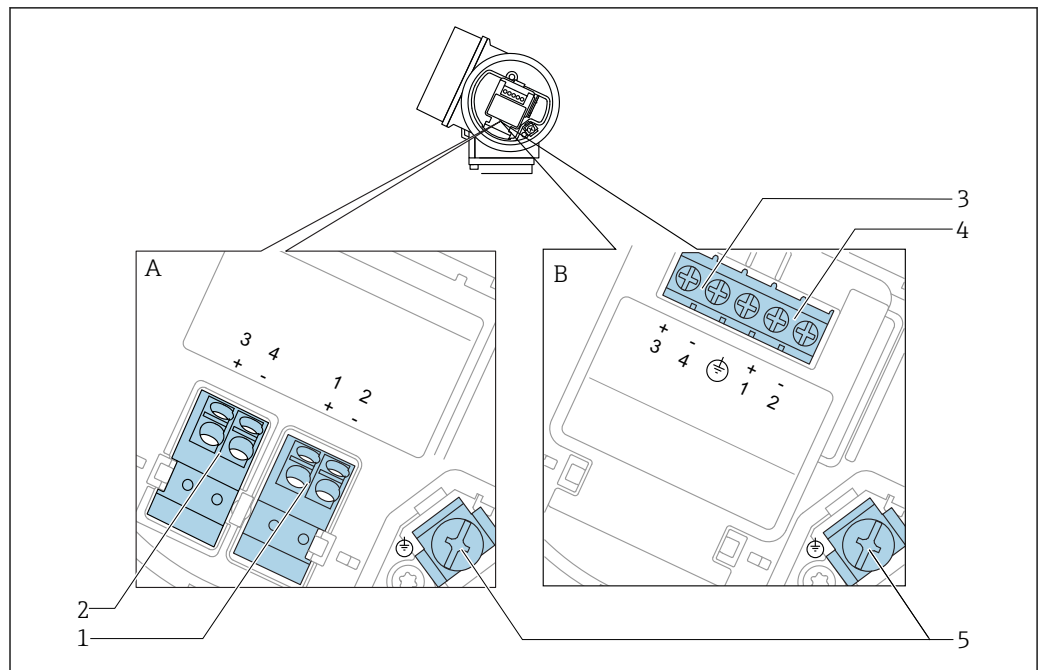

A0036500

6 Terminal assignment 2-wire: 4-20 mA HART, 4-20 mA

A Without integrated overvoltage protection

B With integrated overvoltage protection

1 Connection current output 1, 4-20 mA HART passive: terminals 1 and 2, without integrated overvoltage protection

2 Connection current output 2, 4-20 mA: terminals 3 and 4, without integrated overvoltage protection

3 Connection current output 2, 4-20 mA: terminals 3 and 4, with integrated overvoltage protection

4 Connection current output 1, 4-20 mA HART passive: terminals 1 and 2, with integrated overvoltage protection

5 Terminal for cable screen

Block diagram 2-wire: 4-20 mA HART, 4-20 mA

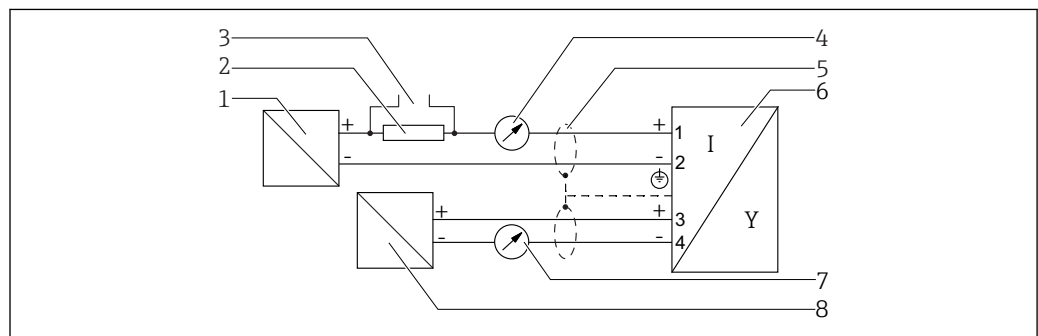

A0036502

7 Block diagram 2-wire: 4-20 mA HART, 4-20 mA

1 Active barrier with power supply (e.g. RN221N); observe terminal voltage

2 HART communication resistor ($\geq 250 \Omega$); observe maximum load

3 Connection for Commubox FXA195 or FieldXpert SFX350/SFX370 (via VIATOR Bluetooth modem)

4 Analog display device; observe maximum load

5 Cable screen; observe cable specification

6 Measuring device

7 Analog display device; observe maximum load

8 Active barrier with power supply (e.g. RN221N), current output 2; observe terminal voltage

Terminal assignment 4-wire: 4-20 mA HART (10.4 to 48 V_{DC})

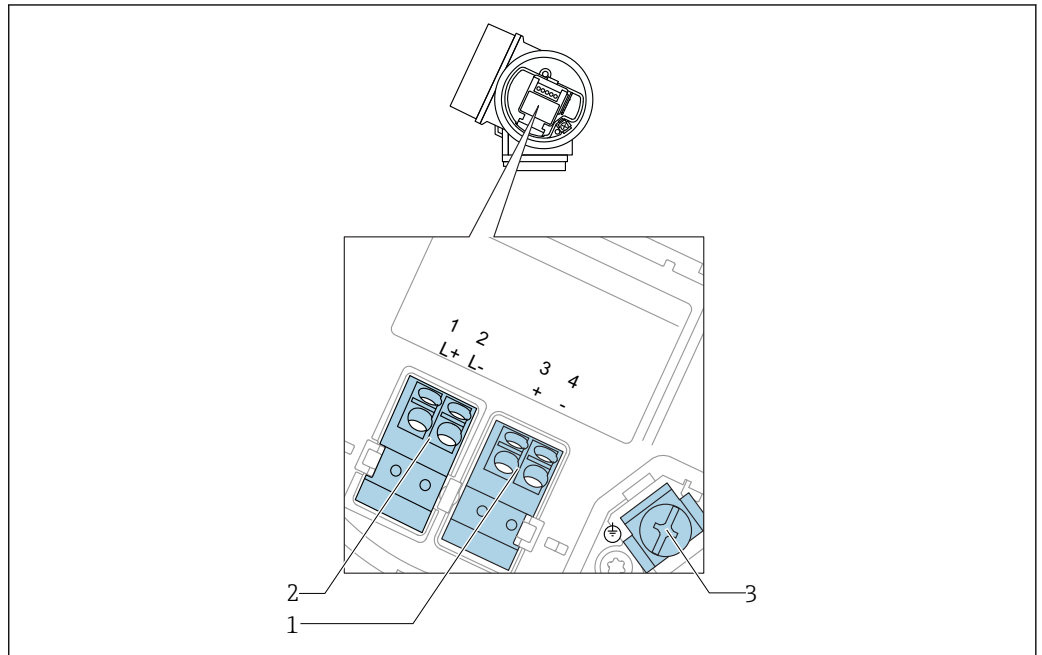

A0036516

8 Terminal assignment 4-wire: 4-20 mA HART (10.4 to 48 V_{DC})

- 1 Connection 4-20 mA HART (active): terminals 3 and 4
- 2 Connection supply voltage: terminals 1 and 2
- 3 Terminal for cable screen

Block diagram 4-wire: 4-20 mA HART (10.4 to 48 V_{DC})

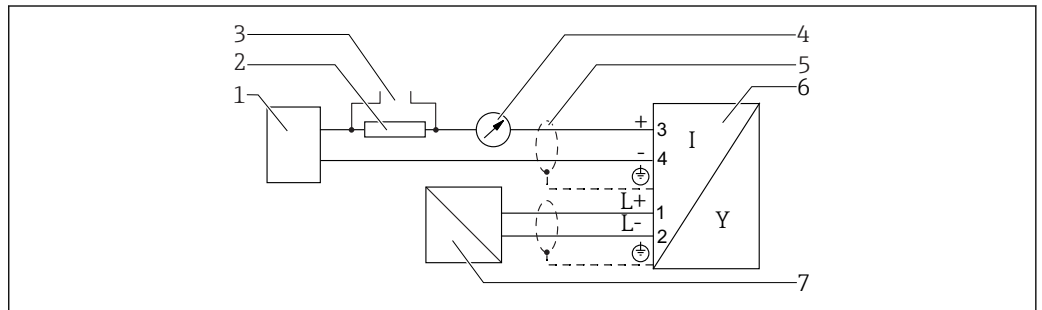

A0036526

9 Block diagram 4-wire: 4-20 mA HART (10.4 to 48 V_{DC})

- 1 Evaluation unit, e.g. PLC
- 2 HART communication resistor ($\geq 250 \Omega$); observe maximum load
- 3 Connection for Commubox FXA195 or FieldXpert SFX350/SFX370 (via VIATOR Bluetooth modem)
- 4 Analog display device; observe maximum load
- 5 Cable screen; observe cable specification
- 6 Measuring device
- 7 Supply voltage; observe terminal voltage, observe cable specification

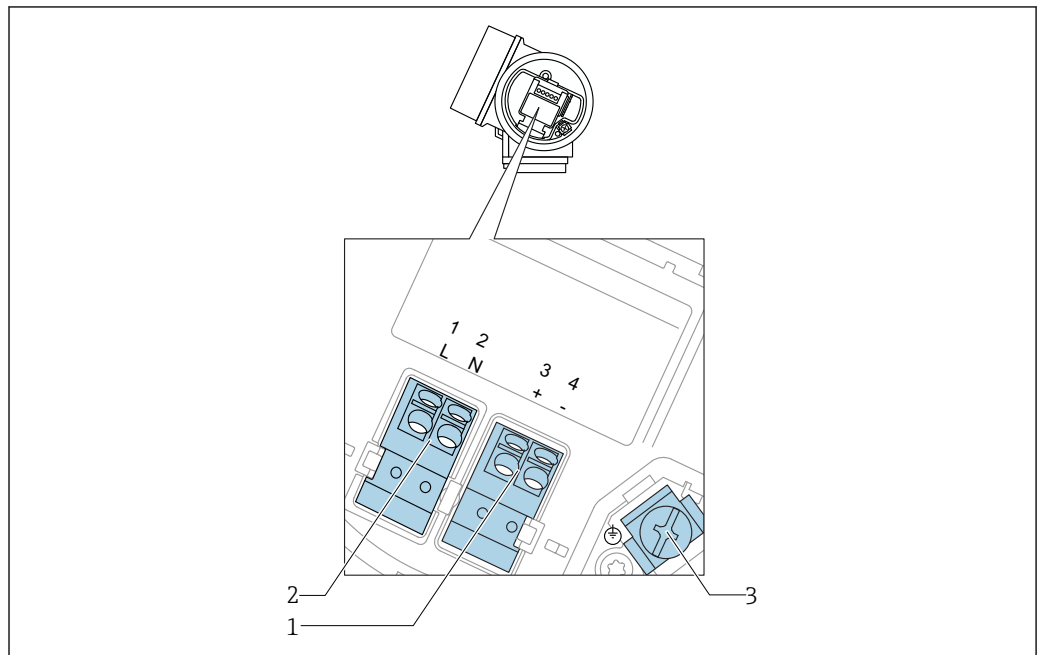
Terminal assignment 4-wire: 4-20 mA HART (90 to 253 V_{AC})

A0036519

10 Terminal assignment 4-wire: 4-20 mA HART (90 to 253 V_{AC})

- 1 Connection 4-20 mA HART (active): terminals 3 and 4
- 2 Connection supply voltage: terminals 1 and 2
- 3 Terminal for cable screen

⚠ CAUTION

To ensure electrical safety:

- ▶ Do not disconnect the protective connection.
- ▶ Disconnect the supply voltage before disconnecting the protective earth.

- i** Connect protective earth to the internal ground terminal (3) before connecting the supply voltage. If necessary, connect the potential matching line to the external ground terminal.
- i** In order to ensure electromagnetic compatibility (EMC): Do **not** only ground the device via the protective earth conductor of the supply cable. Instead, the functional grounding must also be connected to the process connection (flange or threaded connection) or to the external ground terminal.
- i** An easily accessible power switch must be installed in the proximity of the device. The power switch must be marked as a disconnect for the device (IEC/EN61010).

Block diagram 4-wire: 4-20 mA HART (90 to 253 V_{AC})

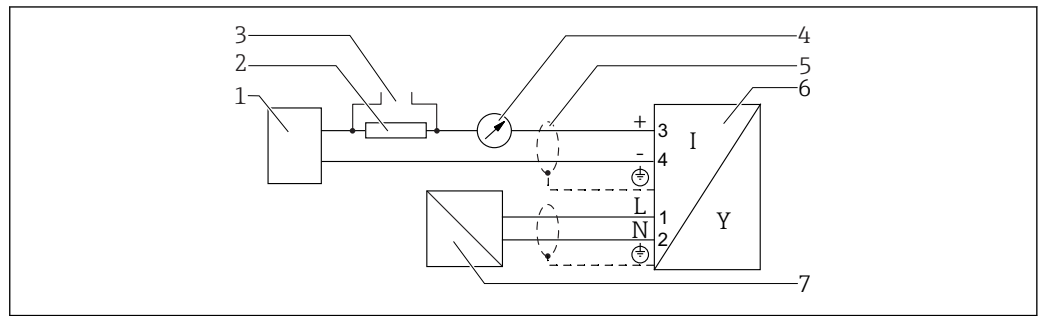

A0036527

11 Block diagram 4-wire: 4-20 mA HART (90 to 253 V_{AC})

- 1 Evaluation unit, e.g. PLC
- 2 HART communication resistor ($\geq 250 \Omega$); observe maximum load
- 3 Connection for Commubox FXA195 or FieldXpert SFX350/SFX370 (via VIATOR Bluetooth modem)
- 4 Analog display device; observe maximum load
- 5 Cable scree; observe cable specification
- 6 Measuring device
- 7 Supply voltage; observe terminal voltage, observe cable specification

Terminal assignment PROFIBUS PA / FOUNDATION Fieldbus

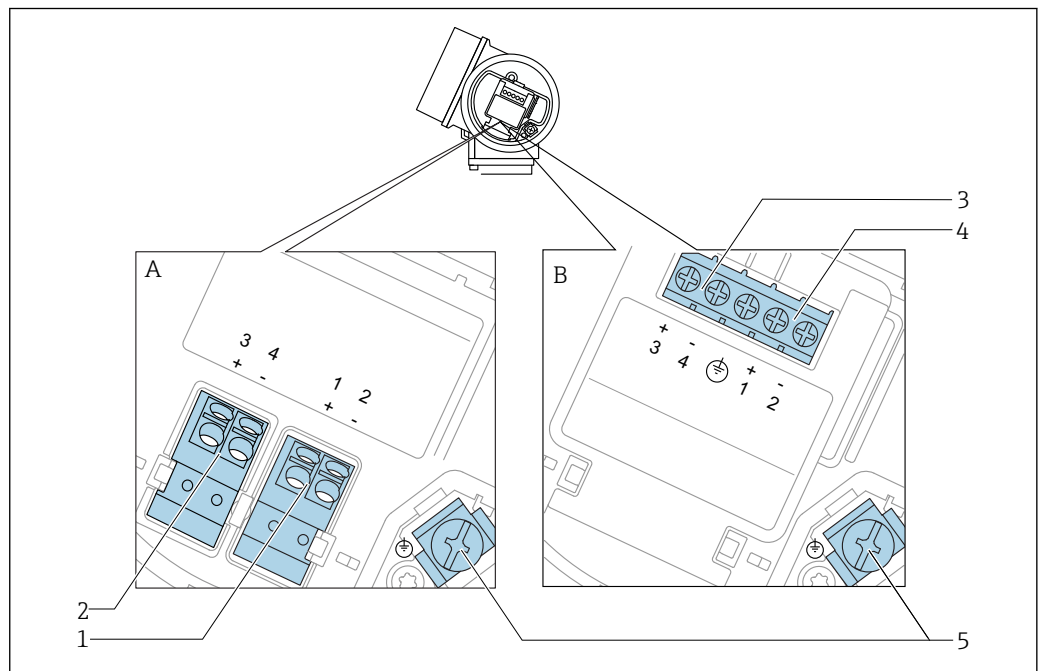

A0036500

12 Terminal assignment PROFIBUS PA / FOUNDATION Fieldbus

- A Without integrated overvoltage protection
- B With integrated overvoltage protection
- 1 Connection PROFIBUS PA / FOUNDATION Fieldbus: terminals 1 and 2, without integrated overvoltage protection
- 2 Connection switch output (Open Collector): terminals 3 and 4, without integrated overvoltage protection
- 3 Connection switch output (Open Collector): terminals 3 and 4, with integrated overvoltage protection
- 4 Connection PROFIBUS PA / FOUNDATION Fieldbus: terminals 1 and 2, with integrated overvoltage protection
- 5 Terminal for cable screen

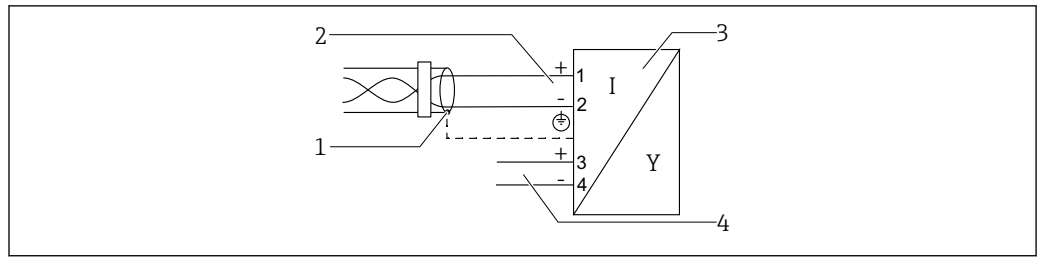
Block diagram PROFIBUS PA / FOUNDATION Fieldbus

A0036530

13 Block diagram PROFIBUS PA / FOUNDATION Fieldbus

- 1 Cable screen; observe cable specifications
- 2 Connection PROFIBUS PA / FOUNDATION Fieldbus
- 3 Measuring device
- 4 Switch output (open collector)

Connection examples for the switch output

i For HART devices, the switch output is available as an option. See product structure, feature 20: "Power Supply, Output", option B: "2-wire; 4-20 mA HART, switch output"

Devices with PROFIBUS PA and FOUNDATION Fieldbus always have a switch output.

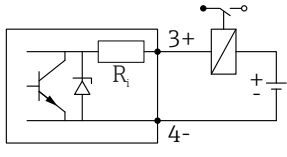
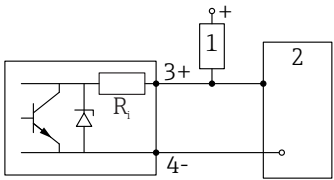
 <p>14 Connection of a relay</p> <p>Suitable relays (examples):</p> <ul style="list-style-type: none"> ▪ Solid-state relay: Phoenix Contact OV-24DC/480AC/5 with mounting rail connector UMK-1 OM-R/AMS ▪ Electromechanical relay: Phoenix Contact PLC-RSC-12DC/21 	 <p>15 Connection of a digital input</p> <p>1 Pull-up resistor 2 Digital input</p>
------------------------------------------------------------------------------------------------------------------------------------------------------------------------------------------------------------------------------------------------------------------------------------------------------------------------------------------------------------------------------------	----------------------------------------------------------------------------------------------------------------------------------------------------------------------------------

i For optimum interference immunity we recommend to connect an external resistor (internal resistance of the relay or Pull-up resistor) of $< 1\,000\ \Omega$.

Device plug connectors

For the versions with fieldbus plug connector (M12 or 7/8"), the signal line can be connected without opening the housing.

Pin assignment of the M12 plug connector

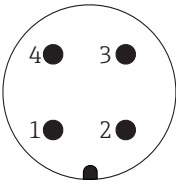
 <small>A0011175</small>	Pin	Meaning
	1	Signal +
	2	not connected
	3	Signal -
	4	Ground

Pin assignment of the 7/8" plug connector

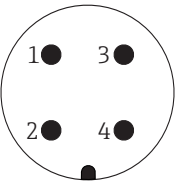
 <small>A0011176</small>	Pin	Meaning
	1	Signal -
	2	Signal +
	3	Not connected
	4	Screen

Supply voltage

An external power supply is required.



Various supply units can be ordered from Endress+Hauser: see "Accessories" section → 107

2-wire, 4-20mA HART, passive

"Power Supply, Output" ¹⁾	"Approval" ²⁾	Terminal voltage U at the device	Maximum load R, depending on the supply voltage U ₀ at the supply unit
A: 2-wire; 4-20mA HART	<ul style="list-style-type: none"> ▪ Non-Ex ▪ Ex nA ▪ Ex ic ▪ CSA GP 	10.4 to 35 V ^{3) 4) 5)}	<p style="text-align: right; font-size: small;">A0017140</p>
	Ex ia / IS	10.4 to 30 V ^{3) 4) 5)}	
	<ul style="list-style-type: none"> ▪ Ex d(ia) / XP ▪ Ex ic(ia) ▪ Ex nA(ia) ▪ Ex ta / DIP 	13 to 35 V ^{5) 6)}	<p style="text-align: right; font-size: small;">A0034771</p>
	Ex ia + Ex d(ia) / IS + XP	13 to 30 V ^{5) 6)}	

- 1) Feature 020 of the product structure
- 2) Feature 010 of the product structure
- 3) For ambient temperatures $T_a \leq -20\text{ °C}$ (-4 °F) a minimum voltage of 15 V is required for the startup of the device at the minimum error current (3,6 mA). The startup current can be parametrized. If the device is operated with a fixed current $I \geq 5,5\text{ mA}$ (HART multidrop mode), a voltage of $U \geq 10,4\text{ V}$ is sufficient throughout the entire range of ambient temperatures.
- 4) In the current simulation mode a voltage $U \geq 12,5\text{ V}$ is required.
- 5) If the Bluetooth modem is used, the minimum supply voltage increases by 3 V.
- 6) For ambient temperatures $T_a \leq -20\text{ °C}$ (-4 °F) a minimum voltage of 16 V is required for the startup of the device at the minimum error current (3.6 mA).

"Power Supply, Output" ¹⁾	"Approval" ²⁾	Terminal voltage U at the device	Maximum load R, depending on the supply voltage U ₀ at the supply unit
B: 2-wire; 4-20 mA HART, switch output	<ul style="list-style-type: none"> ▪ Non-Ex ▪ Ex nA ▪ Ex nA(ia) ▪ Ex ic ▪ Ex ic(ia) ▪ Ex d(ia) / XP ▪ Ex ta / DIP ▪ CSA GP 	13 to 35 V ^{3) 4)}	
	<ul style="list-style-type: none"> ▪ Ex ia / IS ▪ Ex ia + Ex d(ia) / IS + XP 	13 to 30 V ^{3) 4)}	

A0034771

- 1) Feature 020 of the product structure
- 2) Feature 010 of the product structure
- 3) For ambient temperatures $T_a \leq -30\text{ °C}$ (-22 °F) a minimum voltage of 16 V is required for the startup of the device at the minimum error current (3.6 mA).
- 4) If the Bluetooth modem is used, the minimum supply voltage increases by 3 V.

"Power Supply, Output" ¹⁾	"Approval" ²⁾	Terminal voltage U at the device	Maximum load R, depending on the supply voltage U ₀ at the supply unit
C: 2-wire; 4-20mA HART, 4-20mA	any	13 to 28 V ^{3) 4)}	

A0034841

- 1) Feature 020 of the product structure
- 2) Feature 010 of the product structure
- 3) For ambient temperatures $T_a \leq -30\text{ °C}$ (-22 °F) a minimum voltage of 16 V is required for the startup of the device at the minimum error current (3.6 mA).
- 4) If the Bluetooth modem is used, the minimum supply voltage increases by 3 V.

Polarity reversal protection	Yes
Admissible residual ripple at f = 0 to 100 Hz	$U_{SS} < 1\text{ V}$
Admissible residual ripple at f = 100 to 10000 Hz	$U_{SS} < 10\text{ mV}$

4-wire, 4-20mA HART, active

"Power supply; Output" ¹⁾	Terminal voltage	Maximum load R _{max}
K: 4-wire 90-253VAC; 4-20mA HART	90 to 253 V _{AC} (50 to 60 Hz), overvoltage category II	500 Ω
L: 4-wire 10,4-48VDC; 4-20mA HART	10.4 to 48 V _{DC}	

1) Feature 020 of the product structure

PROFIBUS PA, FOUNDATION Fieldbus

"Power supply; Output" ¹⁾	"Approval" ²⁾	Terminal voltage
E: 2-wire; FOUNDATION Fieldbus, switch output G: 2-wire; PROFIBUS PA, switch output	<ul style="list-style-type: none"> ▪ Non-Ex ▪ Ex nA ▪ Ex nA(ia) ▪ Ex ic ▪ Ex ic(ia) ▪ Ex d(ia) / XP ▪ Ex ta / DIP ▪ CSA GP 	9 to 32 V ³⁾
	<ul style="list-style-type: none"> ▪ Ex ia / IS ▪ Ex ia + Ex d(ia) / IS + XP 	9 to 30 V ³⁾

1) Feature 020 of the product structure

2) Feature 010 of the product structure

3) Input voltages up to 35 V will not spoil the device.

Polarity sensitive	No
FISCO/FNICO compliant according to IEC 60079-27	Yes

Power consumption

"Power supply; Output" ¹⁾	Power consumption
A: 2-wire; 4-20mA HART	< 0.9 W
B: 2-wire; 4-20mA HART, switch output	< 0.9 W
C: 2-wire; 4-20mA HART, 4-20mA	< 2 x 0.7 W
K: 4-wire 90-253VAC; 4-20mA HART	6 VA
L: 4-wire 10,4-48VDC; 4-20mA HART	1.3 W

1) Feature 020 of the product structure

Current consumption

HART

Nominal current	3.6 to 22 mA, the start-up current for multidrop mode can be parametrized (is set to 3.6 mA on delivery)
Breakdown signal (NAMUR NE43)	adjustable: 3.59 to 22.5 mA

PROFIBUS PA

Nominal current	14 mA
Failure current FDE (Fault Disconnection Electronic)	0 mA

FOUNDATION Fieldbus

Device basic current	15 mA
Failure current FDE (Fault Disconnection Electronic)	0 mA

FISCO

U_i	17.5 V
I_i	550 mA
P_i	5.5 W
C_i	5 nF
L_i	10 μ H

Power supply failure

- Configuration is retained in the HistoROM (EEPROM).
- Error messages (incl. value of operated hours counter) are stored.

Potential equalization

No special measures for potential equalization are required.



If the device is designed for hazardous areas, observe the information in the documentation "Safety Instructions" (XA).

Terminals

- **Without integrated overvoltage protection**
Plug-in spring terminals for wire cross-sections 0.5 to 2.5 mm² (20 to 14 AWG)
- **With integrated overvoltage protection**
Screw terminals for wire cross-sections 0.2 to 2.5 mm² (24 to 14 AWG)

Cable entries

Connection of power supply and signal line

To be selected in feature 050 "Electrical connection"

- Gland M20; Material dependent on the approval:
 - For Non-Ex, ATEX, IECEx, NEPSI Ex ia/ic:
Plastics M20x1.5 for cable \varnothing 5 to 10 mm (0.2 to 0.39 in)
 - For Dust-Ex, FM IS, CSA IS, CSA GP, Ex nA:
 - For Ex d:
No gland available
- Thread
 - 1/2" NPT
 - G 1/2"
 - M20 \times 1.5
- Plug M12 / Plug 7/8"
Only available for Non-Ex, Ex ic, Ex ia

Connection of remote display FHX50

Feature 030 "Display, Operation"	Cable entry for FHX50 connection
L: "Prepared for display FHX50 + M12 connection"	M12 socket
M: "Prepared for display FHX50 + M16 gland, custom connection"	M12 cable gland
N: "Prepared for display FHX50 + NPT1/2 thread, custom connection"	NPT1/2 thread

Cable specification

- **Devices without integrated overvoltage protection**
Pluggable spring-force terminals for wire cross-sections 0.5 to 2.5 mm² (20 to 14 AWG)
- **Devices with integrated overvoltage protection**
Screw terminals for wire cross-sections 0.2 to 2.5 mm² (24 to 14 AWG)
- For ambient temperature $T_U \geq 60$ °C (140 °F): use cable for temperature $T_U + 20$ K.

HART

- A normal device cable suffices if only the analog signal is used.
- A shielded cable is recommended if using the HART protocol. Observe grounding concept of the plant.
- For 4-wire devices: Standard device cable is sufficient for the power line.

PROFIBUS

Use a twisted, screened two-wire cable, preferably cable type A.

-  For further information on the cable specifications, see Operating Instructions BA00034S "PROFIBUS DP/PA: Guidelines for planning and commissioning", PNO Guideline 2.092 "PROFIBUS PA User and Installation Guideline" and IEC 61158-2 (MBP).

FOUNDATION Fieldbus

Endress+Hauser recommends using twisted, shielded two-wire cables.

-  For further information on the cable specifications, see Operating Instructions BA00013S "FOUNDATION Fieldbus Overview", FOUNDATION Fieldbus Guideline and IEC 61158-2 (MBP).

Overvoltage protection

If the measuring device is used for level measurement in flammable liquids which requires the use of overvoltage protection according to DIN EN 60079-14, standard for test procedures 60060-1 (10 kA, pulse 8/20 µs), an overvoltage protection module has to be installed.

Integrated overvoltage protection module

An integrated overvoltage protection module is available for 2-wire HART as well as PROFIBUS PA and FOUNDATION Fieldbus devices.

Product structure: Feature 610 "Accessory mounted", option NA "Overvoltage protection".

Technical data	
Resistance per channel	2 × 0.5 Ω max.
Threshold DC voltage	400 to 700 V
Threshold impulse voltage	< 800 V
Capacitance at 1 MHz	< 1.5 pF
Nominal arrest impulse voltage (8/20 µs)	10 kA

External overvoltage protection module

HAW562 or HAW569 from Endress+Hauser are suited as external overvoltage protection.

Performance characteristics

Reference operating conditions

- Temperature = +24 °C (+75 °F) ±5 °C (±9 °F)
- Pressure = 960 mbar abs. (14 psia) ±100 mbar (±1.45 psi)
- Humidity = 60 % ±15 %
- Reflector: metal plate with a minimum diameter of 1 m (40 in)
- No major interference reflections inside the signal beam

Maximum measured error

Typical data under reference operating conditions: DIN EN IEC 61298-2 / DIN EN IEC 60770-1; percentage values in relation to the span.

Device	Value	Output	
		digital	analog ¹⁾
FMR53/FMR54	Sum of non-linearity, nonrepeatability and hysteresis	± 6 mm (0.24 in) throughout the complete measuring range	± 0.02 %
	Offset/Zero	± 4 mm (0.2 in)	± 0.03 %

1) Only relevant for 4-20mA current output; add error of the analog value to the digital value.

Measured value resolution

Dead band according to DIN EN IEC 61298-2 / DIN EN IEC 60770-1:

- digital: 1 mm
- analog: 1 µA

Reaction time

The reaction time can be parametrized. The following step response times (as per DIN EN IEC 61298-2 / DIN EN IEC 60770-1)¹⁾ are valid if the damping is switched off:

Tank height	Sampling rate	Step response time
< 10 m (33 ft)	≥ 3.6 s ⁻¹	< 0.8 s
< 20 m (66 ft)	≥ 2.7 s ⁻¹	< 1 s

Influence of ambient temperature

The measurements are carried out in accordance with DIN EN IEC 61298-3 / DIN EN IEC 60770-1

- Digital (HART, PROFIBUS PA, FOUNDATION Fieldbus): average $T_K = 3 \text{ mm}/10 \text{ K}$
- Analog (current output):
 - zero point (4 mA): average $T_K = 0.02 \text{ %}/10 \text{ K}$
 - span (20 mA): average $T_K = 0.05 \text{ %}/10 \text{ K}$

Influence of gas layer

High pressures reduce the propagation velocity of the measuring signals in the gas/vapor above the fluid. This effect depends on the kind of gas/vapor and of its temperature. This results in a systematic measuring error that gets bigger as the distance increases between the reference point of the measurement (flange) and the product surface. The following table illustrates this measured error for a few typical gases/vapors (with regard to distance; a positive value means that too large a distance is being measured):

Gas layer	Temperature		Pressure				
	°C	°F	1 bar (14,5 psi)	10 bar (145 psi)	50 bar (725 psi)	100 bar (1450 psi)	160 bar (2320 psi)
Air/ Nitrogen	20	68	0.00 %	0.22 %	1.2 %	2.4 %	3.89 %
	200	392	-0.01 %	0.13 %	0.74 %	1.5 %	2.42 %
	400	752	-0.02 %	0.08 %	0.52 %	1.1 %	1.70 %
Hydrogen	20	68	-0.01 %	0.10 %	0.61 %	1.2 %	2.00 %

1) According to DIN EN IEC 61298-2 / DIN EN IEC 60770-1 the response time is the time which passes after a sudden change of the input signal until the output signal for the first time assumes 90% of the steady-state value.

Gas layer	Temperature		Pressure				
	°C	°F	1 bar (14,5 psi)	10 bar (145 psi)	50 bar (725 psi)	100 bar (1450 psi)	160 bar (2320 psi)
	200	392	-0.02 %	0.05 %	0.37 %	0.76 %	1.23 %
	400	752	-0.02 %	0.03 %	0.25 %	0.53 %	0.86 %
Water (saturated steam)	100	212	0.02 %	-	-	-	-
	180	356	-	2.1 %	-	-	-
	263	505,4	-	-	8.6 %	-	-
	310	590	-	-	-	22 %	-
	364	687	-	-	-	-	41.8 %



When the pressure is known and constant, this measured error can, for example, be compensated by means of a linearization.

Gas phase compensation with external pressure sensor (PROFIBUS PA, FOUNDATION Fieldbus)

PROFIBUS devices can receive the signal of an external pressure sensor through the bus and use it to perform a pressure dependent time-of-flight correction. In the case of saturated steam in the temperature range from 100 to 350 °C (212 to 662 °F), for example, the measuring error of the distance measurement can be reduced by this method from up to 29 % (without compensation) to less than 3 % (with compensation).

Installation

Installation conditions

Mounting position

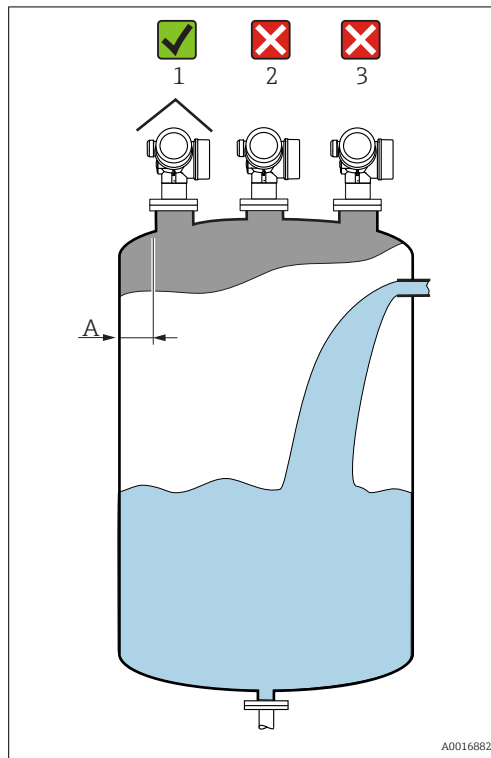

- Recommended distance **A** from wall to outer edge of nozzle: $\sim 1/6$ of tank diameter. Nevertheless the device should not be installed closer than 30 cm (11.8 in) to the tank wall.
- Not in the center (2), as interference can cause signal loss.
- Not above the fill stream (3).
- It is recommended to use a weather protection cover (1) in order to protect the device from direct sun or rain.

Vessel installations

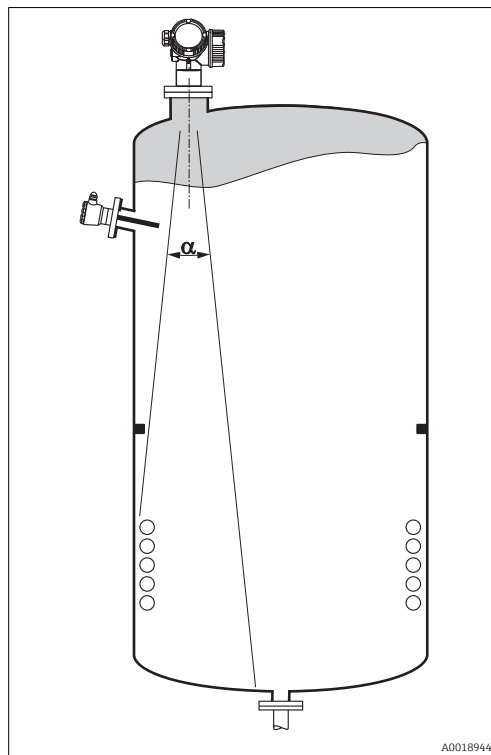

Avoid any installations (point level switches, temperature sensors, braces, vacuum rings, heating coils, baffles etc.) inside the signal beam. Take into account the beam angle
 → 38.

Reduction of interference echoes

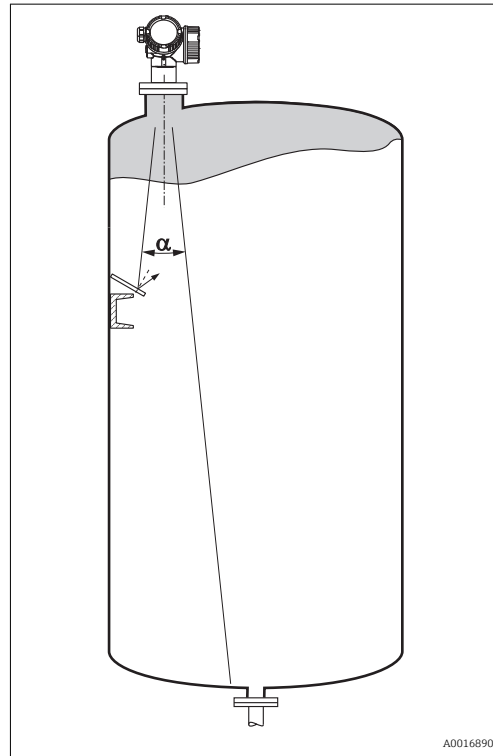

Metallic screens mounted at a slope spread the radar signal and can, therefore, reduce interference echoes.

Measurement in a plastic vessel

If the outer wall of the vessel is made of a non-conductive material (e.g. GRP), microwaves can also be reflected off interfering installations outside the vessel (e.g. metallic pipes (1), ladders (2), grates (3), ...). Therefore, there should be no such interfering installations in the signal beam. Please contact Endress+Hauser for further information.

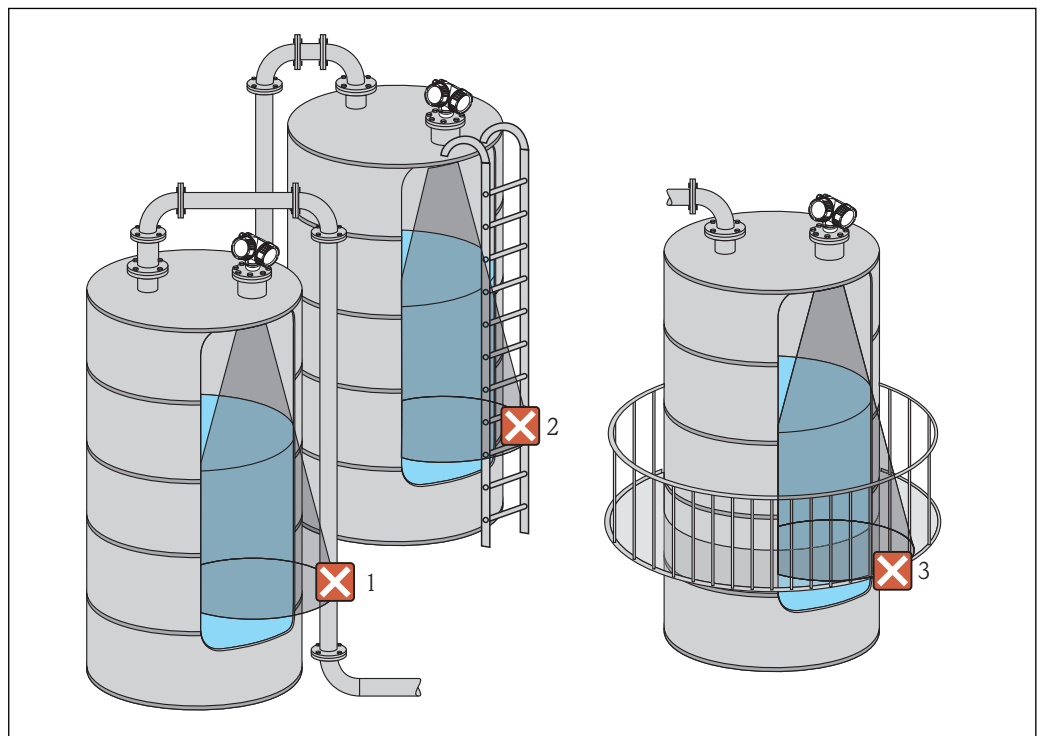

Optimization options

- Antenna size
The bigger the antenna, the smaller the beam angle α and the fewer interference echoes
→ 38.
- Mapping
The measurement can be optimized by means of electronic suppression of interference echoes.
- Antenna alignment
Take into account the marker on the flange or threaded connection .
- Stilling well
A stilling well can be applied to avoid interferences → 44.
- Metallic screens mounted at a slope
They spread the radar signals and can, therefore, reduce interference echoes.

Beam angle

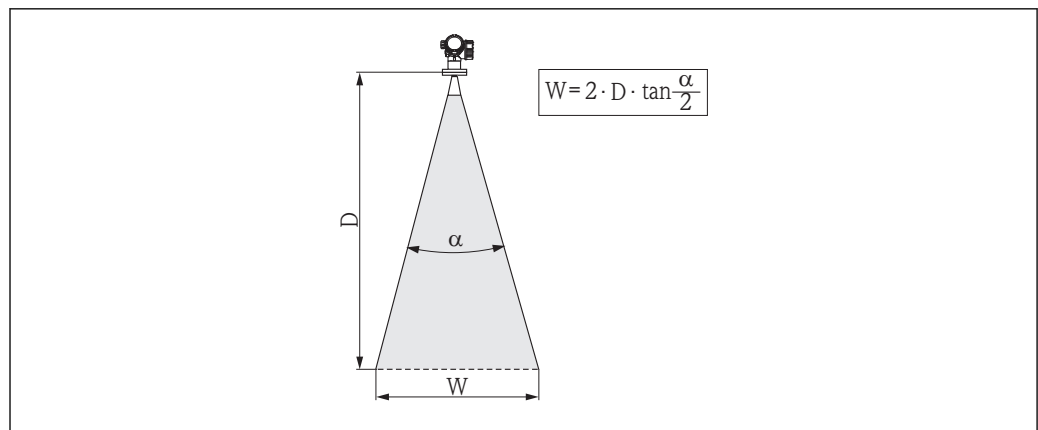

16 Relationship between beam angle α , distance D and beamwidth diameter W

The beam angle is defined as the angle α where the energy density of the radar waves reaches half the value of the maximum energy density (3-dB-width). Microwaves are also emitted outside the signal beam and can be reflected off interfering installations.

Beam diameter W as a function of beam angle α and measuring distance D :

FMR53	
Beam angle α	23°
Measuring distance (D)	Beamwidth diameter W
3 m (9.8 ft)	1.22 m (4 ft)
6 m (20 ft)	2.44 m (8 ft)
9 m (30 ft)	3.66 m (12 ft)
12 m (39 ft)	4.88 m (16 ft)
15 m (49 ft)	6.1 m (20 ft)
20 m (66 ft)	8.14 m (27 ft)

FMR54 - Horn antenna			
Antenna size	150 mm (6 in)	200 mm (8 in)	250 mm (10 in)
Beam angle α	23°	19°	15°
Distance (D)	Beamwidth diameter W		
3 m (9.8 ft)	1.22 m (4 ft)	1 m (3.3 ft)	0.79 m (2.6 ft)
6 m (20 ft)	2.44 m (8 ft)	2.01 m (6.6 ft)	1.58 m (5.2 ft)
9 m (30 ft)	3.66 m (12 ft)	3.01 m (9.9 ft)	2.37 m (7.8 ft)
12 m (39 ft)	4.88 m (16 ft)	4.02 m (13 ft)	3.16 m (10 ft)
15 m (49 ft)	6.1 m (20 ft)	5.02 m (16 ft)	3.95 m (13 ft)
20 m (66 ft)	8.14 m (27 ft)	6.69 m (22 ft)	5.27 m (17 ft)

Measuring conditions

- In case of **boiling surfaces, bubbling** or tendency for **foaming** use FMR53 or FMR54. Depending on its consistence, foam can either absorb microwaves or reflect them off the foam surface. Measurement is possible under certain conditions. For FMR50, FMR51 and FMR52, the additional option "Advanced dynamics" is recommended in these cases (feature 540: "Application Package", option EM).
- In case of heavy **steam development** or **condensate**, the maximum measuring range of FMR50, FMR51 and FMR52 may decrease depending on density, temperature and composition of the steam → use FMR53 or FMR54.
- For the measurement of absorbing gases such as **ammonia NH₃** or some **fluorocarbons**²⁾, please use Levelflex or Micropilot FMR54 in a stilling well.
- The measuring range begins, where the beam hits the tank bottom. Particularly with dish bottoms or conical outlets the level cannot be detected below this point.
- In stilling well applications, the electromagnetic waves do not propagate completely outside the tube. It must be taken into account that the accuracy may be reduced in the area **C**. In order to guarantee the required accuracy in these cases, it is recommended to position the zero-point at a distance **C** above the end of the tube (see figure).
- In case of media with a low dielectric constant ($\epsilon_r = 1.5$ to 4)³⁾ the tank bottom can be visible through the medium at low levels (low height **C**). Reduced accuracy has to be expected in this range. If this is not acceptable, we recommend positioning the zero point at a distance **C** (see figure) above the tank bottom in these applications.
- In principle it is possible to measure up to the tip of the antenna with FMR51, FMR53 and FMR54. However, due to considerations regarding corrosion and build-up, the end of the measuring range should not be chosen any closer than **A** (see figure) to the tip of the antenna.
- When using FMR54 with planar antenna, especially for media with low dielectric constants, the end of the measuring range should not be closer than **A: 1 m (3.28 ft)** to the flange.
- The smallest possible measuring range **B** depends on the antenna version (see figure).
- The tank height should be at least **H** (see table).

2) Affected compounds are e.g. R134a, R227, Dymel 152a.

3) Dielectric constants of important media commonly used in various industries are summarized in the DC manual (CP01076F) and in the Endress+Hauser "DC Values App" (available for Android and iOS).

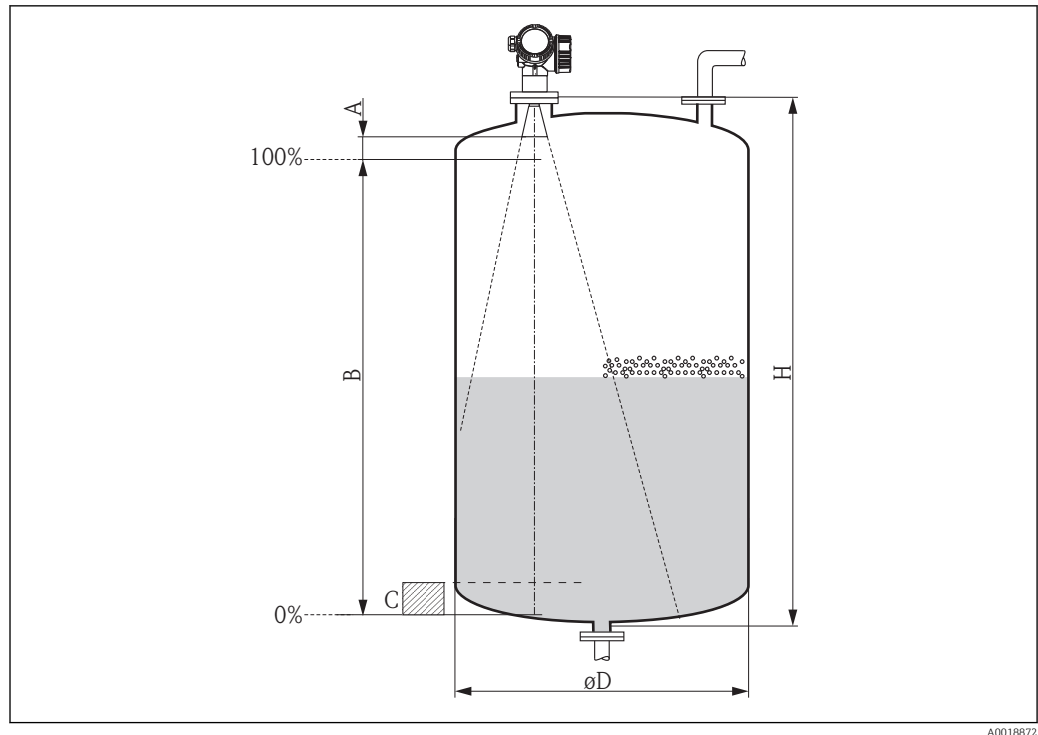

A0018872

Device	A	B	C	H
FMR53	50 mm (1.97 in)	> 0.5 m (1.6 ft)	150 to 300 mm (5.91 to 11.8 in)	> 1.5 m (4.9 ft)
FMR54 - horn antenna	50 mm (1.97 in)			
FMR54 - planar antenna	1 m (3.28 ft)			

Mounting cladded flanges

- i** For cladded flanges of FMR53, observe the following:
 - Use flange screws according to the number of flange holes.
 - Tighten the screws with the required torque (see table).
 - Retighten the screws after 24 hours or after the first temperature cycle.
 - Depending on process pressure and process temperature check and retighten the screws at regular intervals.
- i** Usually, the PTFE flange cladding also serves as a seal between the nozzle and the device flange.

Flange size	Number of screws	Recommended torque [Nm]	
		minimum	maximum
EN			
DN50/PN16	4	45	65
DN80/PN16	8	40	55
DN100/PN16	8	40	60
DN150/PN16	8	75	115
ASME			
2"/150lbs	4	40	55
3"/150lbs	4	65	95
4"/150lbs	8	45	70
6"/150lbs	8	85	125

Flange size	Number of screws	Recommended torque [Nm]	
		minimum	maximum
JIS			
10K 50A	4	40	60
10K 80A	8	25	35
10K 100A	8	35	55
10K 100A	8	75	115

Installation in vessel (free space)

Rod antenna (FMR53)

Alignment

- Align the antenna vertically to the product surface.
- A marking at the flange (somewhere between the flange holes) or the boss enables alignment of the antenna. This marking must be aligned towards the tank wall as well as possible.

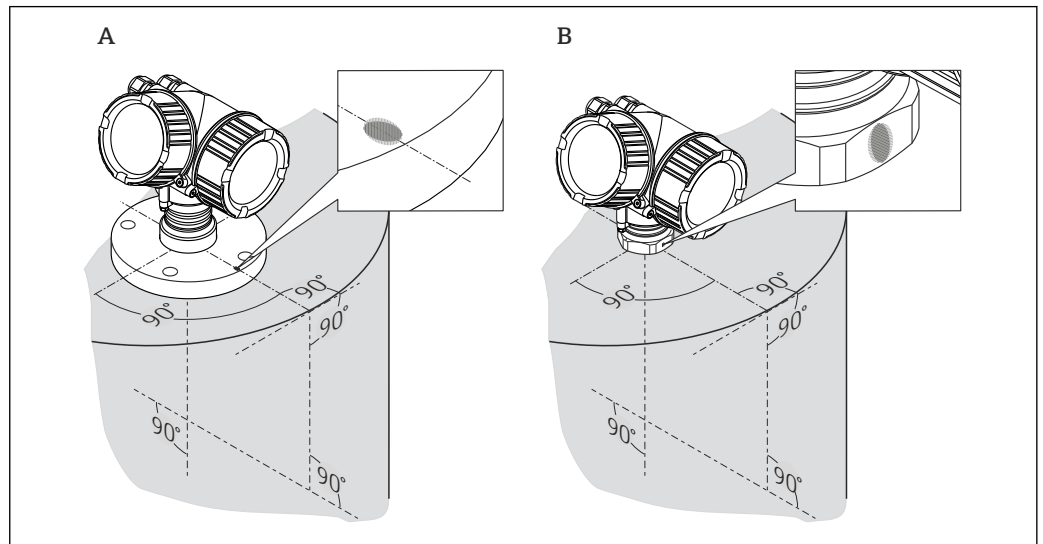

A0018974

 Depending on the device version the marking may be a circle or two short parallel lines.

Nozzle mounting

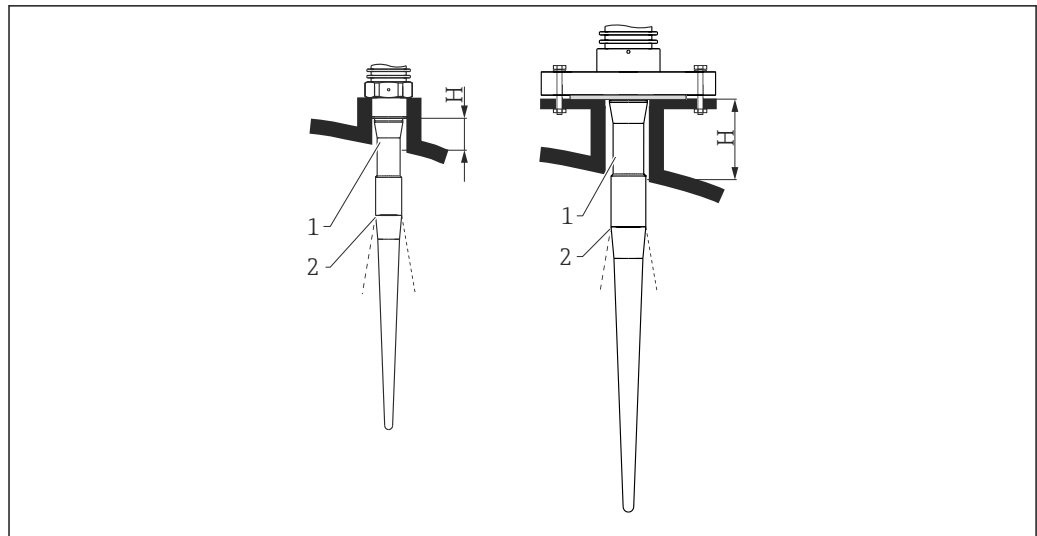

A0016821

17 Nozzle height and diameter for the rod antenna (FMR53)

- 1 Inactive length of the antenna
2 Beam launched here

Antenna length	390 mm (15.4 in)	540 mm (21.3 in)
Nozzle height H	< 100 mm (3.94 in)	< 250 mm (9.84 in)

i The inactive part (1) of the rod antenna must extend below the nozzle.

- i**
- For flanges with PTFE cladding: Observe the notes on the mounting of cladded flanges → 40.
 - Usually, the PTFE flange cladding also serves as a seal between the nozzle and the device flange.

Threaded connection

- Tighten with the hexagonal nut only.
- Tool : 55 mm hexagonal wrench
- Maximum permissible torque:
 - Thread PVDF: 35 Nm (26 lbf ft)
 - Thread 316L: 60 Nm (44 lbf ft)

Horn antenna (FMR54)

Alignment

- Align the antenna vertically to the product surface.
- A marking at the flange (somewhere between the flange holes) enables alignment of the antenna. This marking must be aligned towards the tank wall as well as possible.

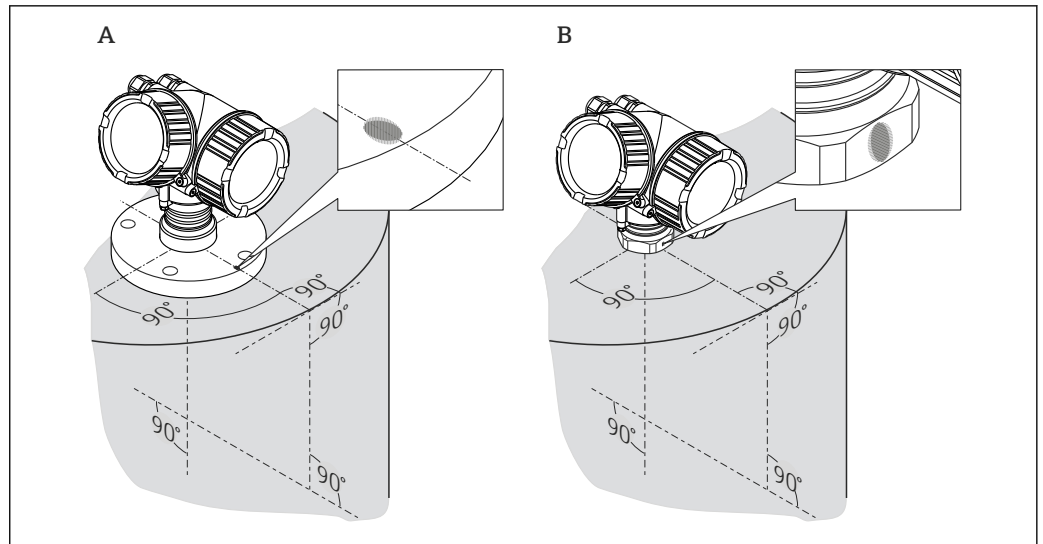

A0018974

i Depending on the device version the marking may be a circle or two short parallel lines.

Nozzle mounting

The horn antenna must extend below the nozzle; if necessary select the device version with antenna extension 100 to 400 mm (4 to 16 in) ⁴⁾.

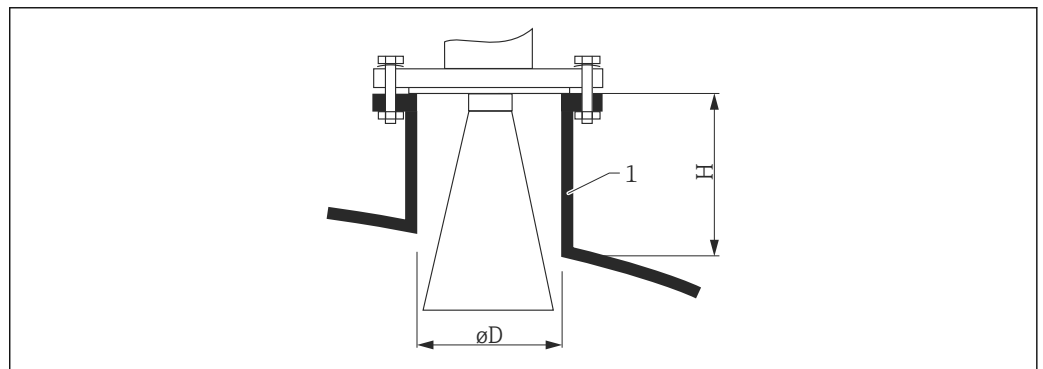

A0016822

18 Nozzle height and diameter for the horn antenna (FMR54)

1 Mounting nozzle

Antenna ¹⁾	Nozzle diameter D	Maximum nozzle height H_{max} ²⁾
BE: 150mm/6"	146 mm (5.75 in)	185 mm (7.28 in)
BF: 200mm/8"	191 mm (7.52 in)	268 mm (10.6 in)
BG: 250mm/10"	241 mm (9.49 in)	360 mm (14.2 in)

- 1) Feature 070 of the product structure; the antenna versions BC (Horn 80mm/3") and BD (Horn 100mm/4") should not be mounted directly into the tank. They are only suited for bypass and stilling well applications.
- 2) valid for antennas without antenna extension

Measurement from the outside through plastic walls

- Dielectric constant of the medium: $\epsilon_r > 10$
- If possible use the 250 mm (10 in) antenna.
- The distance between the lower edge of the antenna and the tank should be about 100 mm (4 in).

4) See product structure: feature 610 "Accessory Mounted", options OM, ON, OR, OS.

- If possible, avoid mounting location where condensation or build-up might occur.
- In case of outdoor mounting, the space between antenna and vessel has to be protected from the elements.
- Do not mount any potential reflectors (e.g. pipes) outside the tank in the signal beam.

Suitable thickness of the tank ceiling

Penetrated material	PE	PTFE	PP	Plexiglas
DK / ϵ_r	2.3	2.1	2.3	3.1
Optimum thickness	16 mm (0.65 in)	17 mm (0.68 in)	16 mm (0.65 in)	14 mm (0.56 in)

Planar antenna (FMR54)

The planar antenna is only suited for stilling well applications. It can not be used for free space applications.

Installation in stilling well

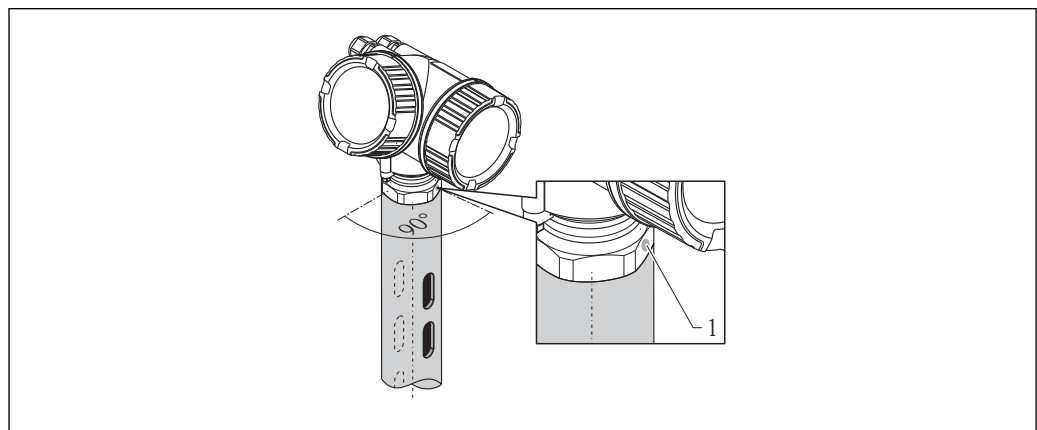

A0016841

19 Installation in stilling well

1 Marking for antenna alignment

- For horn antenna: Align the marking towards the slots of the stilling well.
- No alignment is required for planar antennas.
- Measurements can be performed through an open full bore ball valve without any problems.
- After mounting, the housing can be turned 350° in order to facilitate access to the display and the terminal compartment.

Recommendations for the stilling well

- Metal (no enamel coating; plastic on request).
- Constant diameter.
- Diameter of stilling well not larger than antenna diameter.
- Diameter difference between horn antenna and inner diameter of the stilling well as small as possible.
- Weld seam as smooth as possible and on the same axis as the slots.
- Slots offset 180° (not 90°).
- Slot width or diameter of holes max. 1/10 of pipe diameter, de-burred. Length and number do not have any influence on the measurement.
- Select horn antenna as big as possible. For intermediate sizes (e.g. 180 mm (7 in)) select next larger antenna and adapt it mechanically (for horn antennas)
- At any transition (i.e. when using a ball valve or mending pipe segments), no gap may be left exceeding 1 mm (0.04 in).

- The stilling well must be smooth on the inside (average roughness $R_z \leq 6.3 \mu\text{m}$ (248 μin)). Use extruded or parallel welded metal pipe. An extension of the pipe is possible with welded flanges or pipe sleeves. Flange and pipe have to be properly aligned at the inside.
 - Do not weld through the pipe wall. The inside of the stilling well must remain smooth. In case of unintentional welding through the pipe, the weld seam and any unevenness on the inside need to be carefully removed and smoothened. Otherwise, strong interference echoes will be generated and material build-up will be promoted.
 - In the case of smaller nominal widths flanges must be welded to the pipe such that they allow for a correct orientation (marker aligned toward slots).
-  The performance of Micropilot FMR54 with planar antenna is not dependent on the alignment or geometry of standard stilling wells. No special alignment is required. However, make sure that the planar antenna is installed vertically relative to the stilling well axis.

Examples for the construction of stilling wells

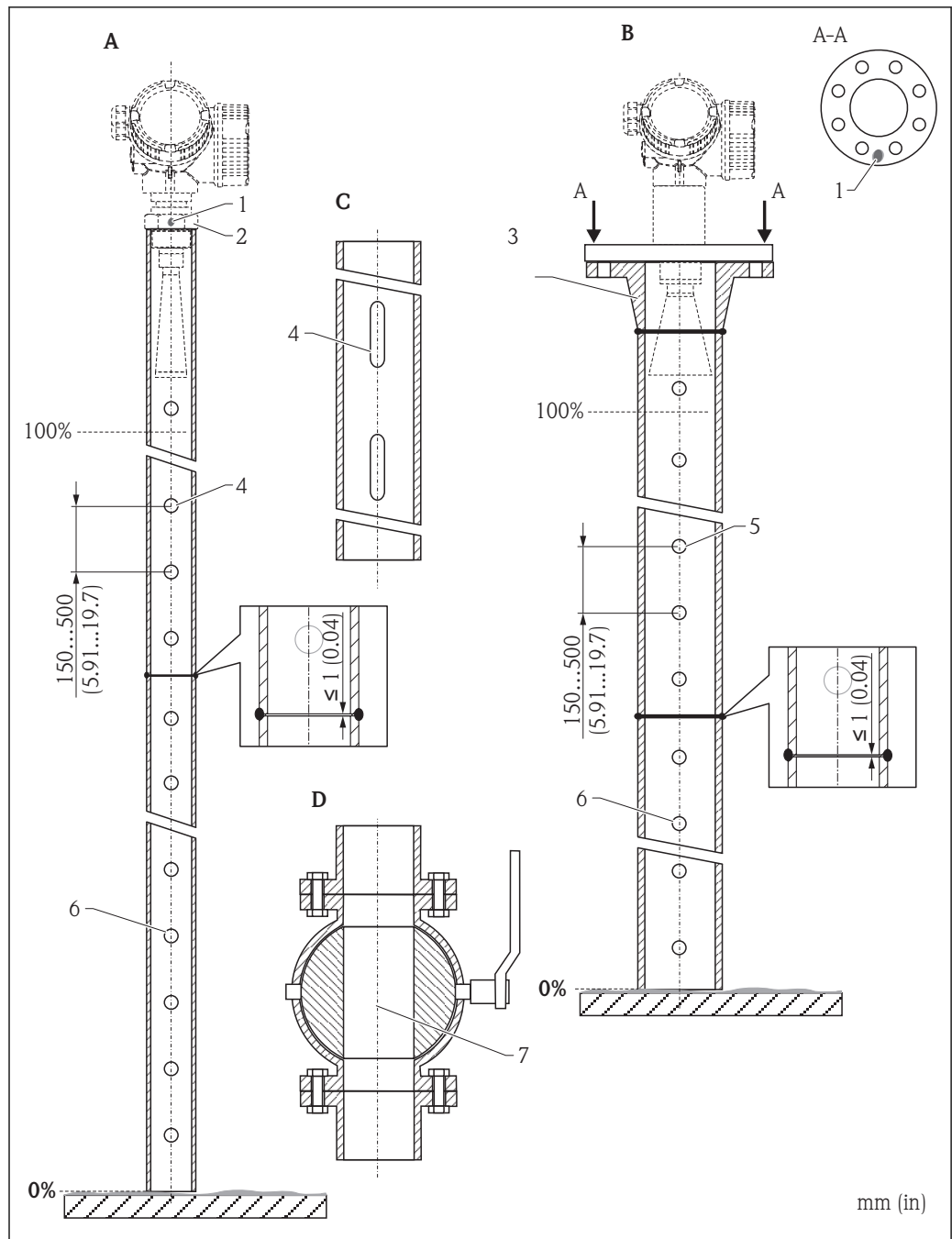

A0019009

- A Micropilot FMR50/FMR51: Horn 40mm(1½")
- B Micropilot FMR50/FMR51/FMR52/FMR54: Horn 80mm(3")
- C Stilling well with slots
- D Full bore ball valve
- 1 Marking for axial alignment
- 2 Threaded connection
- 3 e.g. welding neck flange DIN2633
- 4 ϕ hole max. 1/10 ϕ stilling well
- 5 ϕ hole max. 1/10 ϕ stilling well; single sided or drilled through
- 6 Inside of holes deburred
- 7 Diameter of opening of ball valve must always be equivalent to pipe diameter; avoid edges and constrictions.

Installation in bypass

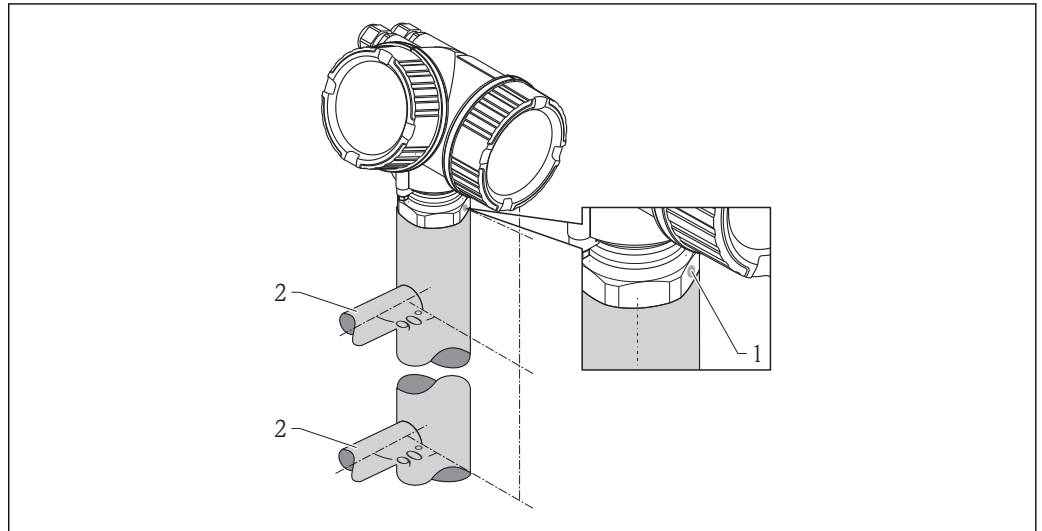

A0019446

20 Installation in bypass

- 1 Marking for antenna alignment
- 2 Tank connectors

- Align the marker perpendicular (90°) to the tank connectors.
- Measurements can be performed through an open full bore ball valve without any problems.
- After mounting, the housing can be turned 350° in order to simplify access to the display and the terminal compartment.

Recommendations for the bypass pipe

- Metal (no plastic or enamel coating).
- Constant diameter.
- Select horn antenna as big as possible. For intermediate sizes (e.g. 95 mm (3.5 in)) select next larger antenna and adapt it mechanically (for horn antennas).
- Diameter difference between horn antenna and inner diameter of the bypass as small as possible.
- At any transition (i.e. when using a ball valve or mending pipe segments), no gap may be created exceeding 1 mm (0.04 in).
- In the area of the tank connections (~ ±20 cm (7.87 in)) a reduced accuracy of the measurement has to be expected.

Example for the construction of a bypass

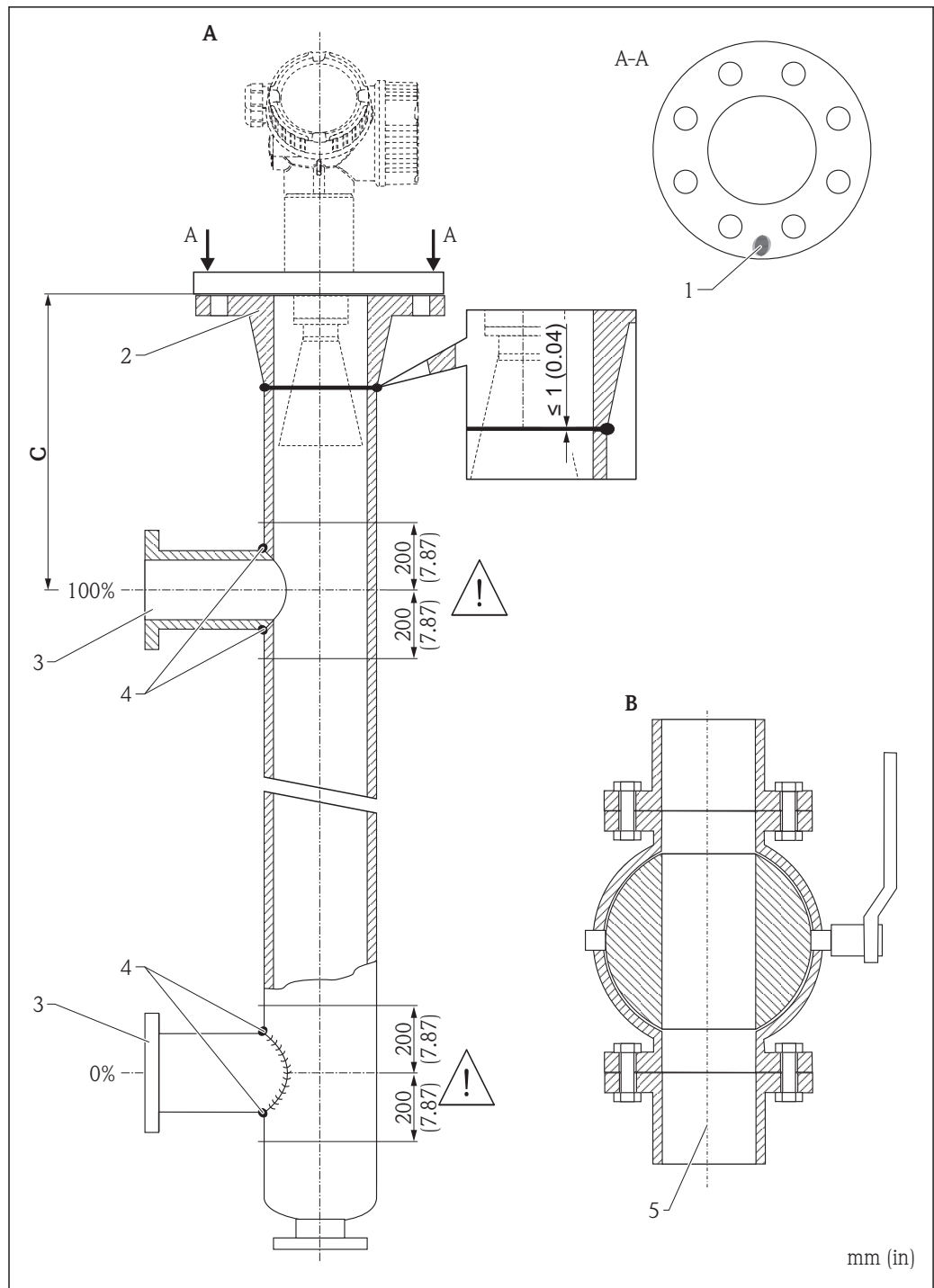

- A Micropilot FMR50/FMR51/FMR52/FMR54: Horn 80mm(3")
- B Full bore ball valve
- C Minimum distance to upper connection pipe: 400 mm (15,7 in)
- 1 Marking for axial alignment
- 2 e.g. welding neck flange DIN2633
- 3 Diameter of the connection pipes as small as possible
- 4 Do not weld through the pipe wall; the inside of the bypass must remain smooth.
- 5 Diameter of opening of ball valve must always be equivalent to pipe diameter. Avoid edges and constrictions.

Container with heat insulation

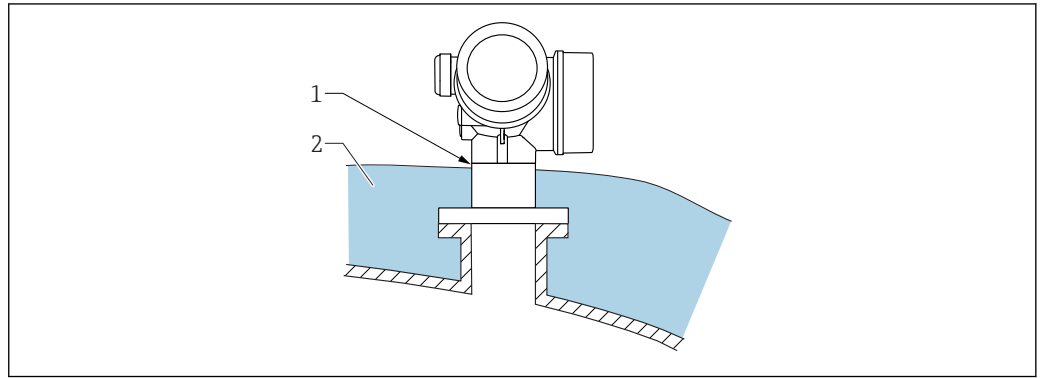

If process temperatures are high, the device should be included in the usual container insulation system (2) to prevent the electronics from heating as a result of thermal radiation or convection. The insulation should not be higher than the neck of the device (1).

Environment

Ambient temperature range	Measuring device	-40 to +80 °C (-40 to +176 °F); -50 °C (-58 °F) with manufacturer declaration on request
	Measuring device (option for FMR51, FMR52 and FMR54)	-50 to +80 °C (-58 to +176 °F) ¹⁾
	Local display	-20 to +70 °C (-4 to +158 °F), the readability of the display may be impaired at temperatures outside the temperature range.
	Remote display FHX50	-40 to 80 °C (-40 to 176 °F)
	Remote display FHX50 (option)	-50 to 80 °C (-58 to 176 °F) ¹⁾

- 1) This range is valid if option JN "Ambient temperature transmitter -50 °C (-58 °F)" has been selected in ordering feature 580 "Test, Certificate". If the temperature is permanently below -40 °C (-40 °F), increased failure rates have to be expected.

When operating the device in the open with strong sunlight:

- Mount the device in a shady position.
- Avoid direct sunlight, especially in warmer regions.
- Use a weather protection cover (see accessories).

Ambient temperature limits



The following diagrams take into account only functional aspects. There may be further restrictions for certified device versions. Please refer to the separate Safety Instructions → 108.

With a temperature (T_p) at the process connection the admissible ambient temperature (T_a) is reduced according to the following diagram (temperature derating):

Information concerning the derating tables

Option	Meaning
A	2-wire; 4-20 mA HART
B	2-wire; 4-20 mA HART, switch output
C	2-wire; 4-20 mA HART, 4-20 mA
E	2-wire; FF, switch output
G	2-wire; PA, switch output
K	4-wire 90-253VAC; 4-20 mA HART
L	4-wire 10, 4-48VDC; 4-20 mA HART

FMR53 Process connection: Thread PVDF Housing: GT18 (316 L) Temperature unit: °C (°F)												
Power Supply; Output (Pos. 2 of the product structure)	P1		P2		P3		P4		P5		P6	
	T_p	T_a	T_p	T_a	T_p	T_a	T_p	T_a	T_p	T_a	T_p	T_a
A	-40 (-40)	80 (176)	80 (176)	80 (176)	80 (176)	80 (176)	80 (176)	-40 (-40)	-40 (-40)	-40 (-40)	-	-
B Switch output not used	-40 (-40)	80 (176)	80 (176)	80 (176)	80 (176)	80 (176)	80 (176)	-40 (-40)	-40 (-40)	-40 (-40)	-	-
B Switch output used	-40 (-40)	77 (171)	77 (171)	77 (171)	80 (176)	76 (169)	80 (176)	-40 (-40)	-40 (-40)	-40 (-40)	-	-

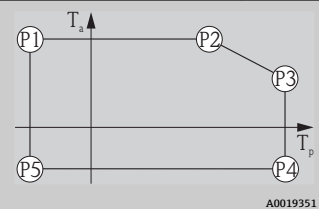

FMR53
Process connection: Thread PVDF
Housing: GT18 (316 L)
Temperature unit: °C (°F)

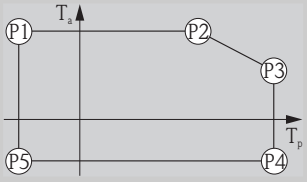

A0019351

Power Supply; Output (Pos. 2 of the product structure)	P1		P2		P3		P4		P5		P6	
	T _p	T _a	T _p	T _a	T _p	T _a	T _p	T _a	T _p	T _a	T _p	T _a
C Channel 2 not used	-40 (-40)	80 (176)	80 (176)	80 (176)	80 (176)	80 (176)	80 (176)	-40 (-40)	-40 (-40)	-40 (-40)	-	-
C Channel 2 used	-40 (-40)	79 (174)	79 (174)	79 (174)	80 (176)	79 (174)	80 (176)	-40 (-40)	-40 (-40)	-40 (-40)	-	-
E, G Switch output not used	-40 (-40)	80 (176)	80 (176)	80 (176)	80 (176)	80 (176)	80 (176)	-40 (-40)	-40 (-40)	-40 (-40)	-	-
E, G Switch output used	-40 (-40)	78 (172)	78 (172)	78 (172)	80 (176)	78 (172)	80 (176)	-40 (-40)	-40 (-40)	-40 (-40)	-	-
K, L	-40 (-40)	77 (171)	77 (171)	77 (171)	80 (176)	77 (171)	80 (176)	-40 (-40)	-40 (-40)	-40 (-40)	-	-

FMR53
Process connection: Thread PVDF
Housing: GT19 (Plastics PBT)
Temperature unit: °C (°F)

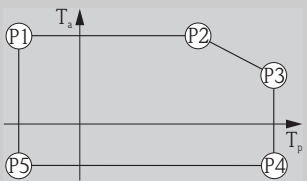

A0019351

Power Supply; Output (Pos. 2 of the product structure)	P1		P2		P3		P4		P5		P6	
	T _p	T _a	T _p	T _a	T _p	T _a	T _p	T _a	T _p	T _a	T _p	T _a
A	-40 (-40)	80 (176)	80 (176)	80 (176)	80 (176)	80 (176)	80 (176)	-40 (-40)	-40 (-40)	-40 (-40)	-	-
B Switch output not used	-40 (-40)	76 (169)	76 (169)	76 (169)	80 (176)	75 (167)	80 (176)	-40 (-40)	-40 (-40)	-40 (-40)	-	-
B Switch output used	-40 (-40)	60 (140)	60 (140)	60 (140)	80 (176)	58 (136)	80 (176)	-40 (-40)	-40 (-40)	-40 (-40)	-	-
C Channel 2 not used	-40 (-40)	80 (176)	80 (176)	80 (176)	80 (176)	80 (176)	80 (176)	-40 (-40)	-40 (-40)	-40 (-40)	-	-
C Channel 2 used	-40 (-40)	74 (165)	74 (165)	74 (165)	80 (176)	73 (163)	80 (176)	-40 (-40)	-40 (-40)	-40 (-40)	-	-
E, G Switch output not used	-40 (-40)	79 (174)	79 (174)	79 (174)	80 (176)	79 (173)	80 (176)	-40 (-40)	-40 (-40)	-40 (-40)	-	-
E, G Switch output used	-40 (-40)	63 (145)	63 (145)	63 (145)	80 (176)	60 (140)	80 (176)	-40 (-40)	-40 (-40)	-40 (-40)	-	-

FMR53
Process connection: Thread PVDF
Housing: GT20 (Alu, coated)
Temperature unit: °C (°F)

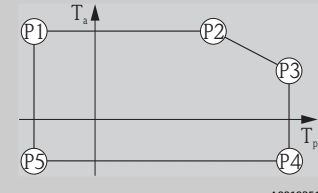

Power Supply; Output (Pos. 2 of the product structure)	P1		P2		P3		P4		P5		P6	
	T _p	T _a	T _p	T _a	T _p	T _a	T _p	T _a	T _p	T _a	T _p	T _a
A	-40 (-40)	80 (176)	80 (176)	80 (176)	80 (176)	80 (176)	80 (176)	-40 (-40)	-40 (-40)	-40 (-40)	-	-
B Switch output not used	-40 (-40)	80 (176)	80 (176)	80 (176)	80 (176)	80 (176)	80 (176)	-40 (-40)	-40 (-40)	-40 (-40)	-	-
B Switch output used	-40 (-40)	77 (171)	77 (171)	77 (171)	80 (176)	76 (169)	80 (176)	-40 (-40)	-40 (-40)	-40 (-40)	-	-
C Channel 2 not used	-40 (-40)	80 (176)	80 (176)	80 (176)	80 (176)	80 (176)	80 (176)	-40 (-40)	-40 (-40)	-40 (-40)	-	-
C Channel 2 used	-40 (-40)	79 (174)	79 (174)	79 (174)	80 (176)	79 (174)	80 (176)	-40 (-40)	-40 (-40)	-40 (-40)	-	-
E, G Switch output not used	-40 (-40)	80 (176)	80 (176)	80 (176)	80 (176)	80 (176)	80 (176)	-40 (-40)	-40 (-40)	-40 (-40)	-	-
E, G Switch output used	-40 (-40)	78 (172)	78 (172)	78 (172)	80 (176)	78 (172)	80 (176)	-40 (-40)	-40 (-40)	-40 (-40)	-	-
K, L	-40 (-40)	77 (171)	77 (171)	77 (171)	80 (176)	77 (171)	80 (176)	-40 (-40)	-40 (-40)	-40 (-40)	-	-

FMR53
Process connection:
 ■ Thread 316L
 ■ Flange
Housing: GT18 (316 L)
Temperature unit: °C (°F)

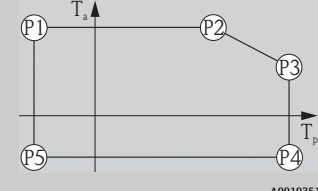

Power Supply; Output (Pos. 2 of the product structure)	P1		P2		P3		P4		P5		P6	
	T _p	T _a	T _p	T _a	T _p	T _a	T _p	T _a	T _p	T _a	T _p	T _a
A	-40 (-40)	81 (178)	81 (178)	81 (178)	150 (302)	65 (149)	150 (302)	-40 (-40)	-40 (-40)	-40 (-40)	-	-
B Switch output not used	-40 (-40)	82 (180)	82 (180)	82 (180)	150 (302)	66 (151)	150 (302)	-40 (-40)	-40 (-40)	-40 (-40)	-	-
B Switch output used	-40 (-40)	77 (171)	77 (171)	77 (171)	150 (302)	59 (138)	150 (302)	-40 (-40)	-40 (-40)	-40 (-40)	-	-
C Channel 2 not used	-40 (-40)	82 (180)	82 (180)	82 (180)	150 (302)	66 (151)	150 (302)	-40 (-40)	-40 (-40)	-40 (-40)	-	-
C Channel 2 used	-40 (-40)	79 (174)	79 (174)	79 (174)	150 (302)	62 (144)	150 (302)	-40 (-40)	-40 (-40)	-40 (-40)	-	-
E, G Switch output not used	-40 (-40)	82 (180)	82 (180)	82 (180)	150 (302)	67 (153)	150 (302)	-40 (-40)	-40 (-40)	-40 (-40)	-	-
E, G Switch output used	-40 (-40)	78 (172)	78 (172)	78 (172)	150 (302)	61 (142)	150 (302)	-40 (-40)	-40 (-40)	-40 (-40)	-	-
K, L	-40 (-40)	77 (171)	77 (171)	77 (171)	150 (302)	60 (140)	150 (302)	-40 (-40)	-40 (-40)	-40 (-40)	-	-

FMR53

Process connection:

- Thread 316L
- Flange

Housing: GT19 (Plastics PBT)
Temperature unit: °C (°F)

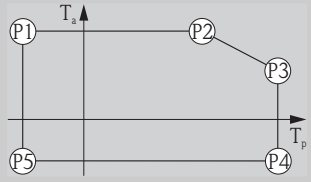

Power Supply; Output (Pos. 2 of the product structure)	P1		P2		P3		P4		P5		P6	
	T _p	T _a	T _p	T _a	T _p	T _a	T _p	T _a	T _p	T _a	T _p	T _a
A	-40 (-40)	80 (176)	80 (176)	80 (176)	150 (302)	55 (131)	150 (302)	-40 (-40)	-40 (-40)	-40 (-40)	-	-
B Switch output not used	-40 (-40)	76 (169)	76 (169)	76 (169)	150 (302)	55 (131)	150 (302)	-40 (-40)	-40 (-40)	-40 (-40)	-	-
B Switch output used	-40 (-40)	60 (140)	60 (140)	60 (140)	150 (302)	37 (99)	150 (302)	-40 (-40)	-40 (-40)	-40 (-40)	-	-
C Channel 2 not used	-40 (-40)	82 (180)	82 (180)	82 (180)	150 (302)	55 (131)	150 (302)	-40 (-40)	-40 (-40)	-40 (-40)	-	-
C Channel 2 used	-40 (-40)	74 (165)	74 (165)	74 (165)	150 (302)	54 (129)	150 (302)	-40 (-40)	-40 (-40)	-40 (-40)	-	-
E, G Switch output not used	-40 (-40)	79 (174)	79 (174)	79 (174)	150 (302)	55 (131)	150 (302)	-40 (-40)	-40 (-40)	-40 (-40)	-	-
E, G Switch output used	-40 (-40)	63 (145)	63 (145)	63 (145)	150 (302)	40 (104)	150 (302)	-40 (-40)	-40 (-40)	-40 (-40)	-	-

FMR53

Process connection:

- Thread 316L
- Flange

Housing: GT20 (Alu, coated)
Temperature unit: °C (°F)

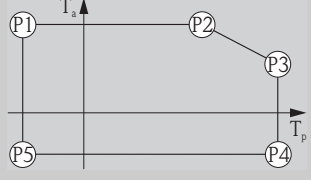

Power Supply; Output (Pos. 2 of the product structure)	P1		P2		P3		P4		P5		P6	
	T _p	T _a	T _p	T _a	T _p	T _a	T _p	T _a	T _p	T _a	T _p	T _a
A	-40 (-40)	81 (178)	81 (178)	81 (178)	150 (302)	68 (154)	150 (302)	-40 (-40)	-40 (-40)	-40 (-40)	-	-
B Switch output not used	-40 (-40)	82 (180)	82 (180)	82 (180)	150 (302)	69 (156)	150 (302)	-40 (-40)	-40 (-40)	-40 (-40)	-	-
B Switch output used	-40 (-40)	77 (171)	77 (171)	77 (171)	150 (302)	63 (145)	150 (302)	-40 (-40)	-40 (-40)	-40 (-40)	-	-
C Channel 2 not used	-40 (-40)	82 (180)	82 (180)	82 (180)	150 (302)	69 (156)	150 (302)	-40 (-40)	-40 (-40)	-40 (-40)	-	-
C Channel 2 used	-40 (-40)	79 (174)	79 (174)	79 (174)	150 (302)	65 (149)	150 (302)	-40 (-40)	-40 (-40)	-40 (-40)	-	-
E, G Switch output not used	-40 (-40)	83 (181)	83 (181)	83 (181)	150 (302)	70 (158)	150 (302)	-40 (-40)	-40 (-40)	-40 (-40)	-	-
E, G Switch output used	-40 (-40)	78 (172)	78 (172)	78 (172)	150 (302)	64 (147)	150 (302)	-40 (-40)	-40 (-40)	-40 (-40)	-	-
K, L	-40 (-40)	77 (171)	77 (171)	77 (171)	150 (302)	64 (147)	150 (302)	-40 (-40)	-40 (-40)	-40 (-40)	-	-

FMR54
Horn antenna

Seal:

- Viton
- EPDM
- Kalrez

Housing: GT18 (316 L)
Temperature unit: °C (°F)

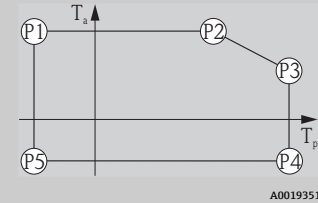

Power Supply; Output (Pos. 2 of the product structure)	P1		P2		P3		P4		P5		P6	
	T _p	T _a	T _p	T _a	T _p	T _a	T _p	T _a	T _p	T _a	T _p	T _a
A	-40 (-40)	81 (178)	81 (178)	81 (178)	200 (392)	52 (126)	200 (392)	-40 (-40)	-40 (-40)	-40 (-40)	-	-
B Switch output not used	-40 (-40)	82 (180)	82 (180)	82 (180)	200 (392)	52 (126)	200 (392)	-40 (-40)	-40 (-40)	-40 (-40)	-	-
B Switch output used	-40 (-40)	77 (171)	77 (171)	77 (171)	200 (392)	46 (115)	200 (392)	-40 (-40)	-40 (-40)	-40 (-40)	-	-
C Channel 2 not used	-40 (-40)	82 (180)	82 (180)	82 (180)	200 (392)	52 (126)	200 (392)	-40 (-40)	-40 (-40)	-40 (-40)	-	-
C Channel 2 used	-40 (-40)	79 (174)	79 (174)	79 (174)	200 (392)	49 (120)	200 (392)	-40 (-40)	-40 (-40)	-40 (-40)	-	-
E, G Switch output not used	-40 (-40)	83 (181)	83 (181)	83 (181)	200 (392)	52 (126)	200 (392)	-40 (-40)	-40 (-40)	-40 (-40)	-	-
E, G Switch output used	-40 (-40)	78 (172)	78 (172)	78 (172)	200 (392)	48 (118)	200 (392)	-40 (-40)	-40 (-40)	-40 (-40)	-	-
K, L	-40 (-40)	77 (171)	77 (171)	77 (171)	200 (392)	47 (117)	200 (392)	-40 (-40)	-40 (-40)	-40 (-40)	-	-

FMR54
Horn antenna

Seal:

- Viton
- EPDM
- Kalrez

Housing: GT19 (Plastics PBT)
Temperature unit: °C (°F)

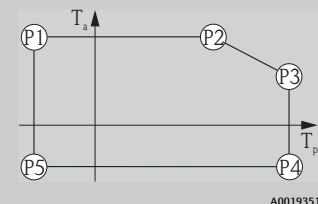

Power Supply; Output (Pos. 2 of the product structure)	P1		P2		P3		P4		P5		P6	
	T _p	T _a	T _p	T _a	T _p	T _a	T _p	T _a	T _p	T _a	T _p	T _a
A	-40 (-40)	80 (176)	80 (176)	80 (176)	200 (392)	29 (84)	200 (392)	-40 (-40)	-40 (-40)	-40 (-40)	-	-
B Switch output not used	-40 (-40)	76 (169)	76 (169)	76 (169)	200 (392)	29 (84)	200 (392)	-40 (-40)	-40 (-40)	-40 (-40)	-	-
B Switch output used	-40 (-40)	60 (140)	60 (140)	60 (140)	200 (392)	23 (73)	200 (392)	-40 (-40)	-40 (-40)	-40 (-40)	-	-
C Channel 2 not used	-40 (-40)	82 (180)	82 (180)	82 (180)	200 (392)	29 (84)	200 (392)	-40 (-40)	-40 (-40)	-40 (-40)	-	-
C Channel 2 used	-40 (-40)	74 (165)	74 (165)	74 (165)	200 (392)	29 (84)	200 (392)	-40 (-40)	-40 (-40)	-40 (-40)	-	-
E, G Switch output not used	-40 (-40)	79 (174)	79 (174)	79 (174)	200 (392)	29 (84)	200 (392)	-40 (-40)	-40 (-40)	-40 (-40)	-	-
E, G Switch output used	-40 (-40)	63 (145)	63 (145)	63 (145)	200 (392)	26 (79)	200 (392)	-40 (-40)	-40 (-40)	-40 (-40)	-	-

FMR54
Horn antenna
Seal:

- Viton
- EPDM
- Kalrez

Housing: GT20 (Alu, coated)
Temperature unit: °C (°F)

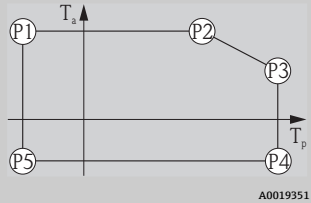

Power Supply; Output (Pos. 2 of the product structure)	P1		P2		P3		P4		P5		P6	
	T _p	T _a	T _p	T _a	T _p	T _a	T _p	T _a	T _p	T _a	T _p	T _a
A	-40 (-40)	81 (178)	81 (178)	81 (178)	200 (392)	57 (135)	200 (392)	-40 (-40)	-40 (-40)	-40 (-40)	-	-
B Switch output not used	-40 (-40)	82 (180)	82 (180)	82 (180)	200 (392)	58 (136)	200 (392)	-40 (-40)	-40 (-40)	-40 (-40)	-	-
B Switch output used	-40 (-40)	77 (171)	77 (171)	77 (171)	200 (392)	52 (126)	200 (392)	-40 (-40)	-40 (-40)	-40 (-40)	-	-
C Channel 2 not used	-40 (-40)	82 (180)	82 (180)	82 (180)	200 (392)	58 (136)	200 (392)	-40 (-40)	-40 (-40)	-40 (-40)	-	-
C Channel 2 used	-40 (-40)	79 (174)	79 (174)	79 (174)	200 (392)	54 (129)	200 (392)	-40 (-40)	-40 (-40)	-40 (-40)	-	-
E, G Switch output not used	-40 (-40)	83 (181)	83 (181)	83 (181)	200 (392)	58 (136)	200 (392)	-40 (-40)	-40 (-40)	-40 (-40)	-	-
E, G Switch output used	-40 (-40)	78 (172)	78 (172)	78 (172)	200 (392)	54 (129)	200 (392)	-40 (-40)	-40 (-40)	-40 (-40)	-	-
K, L	-40 (-40)	77 (171)	77 (171)	77 (171)	200 (392)	53 (127)	200 (392)	-40 (-40)	-40 (-40)	-40 (-40)	-	-

FMR54
Horn antenna
Seal: Graphite -196 to 280 °C (-321 to 536 °F)
Housing: GT18 (316 L)
Temperature unit: °C (°F)

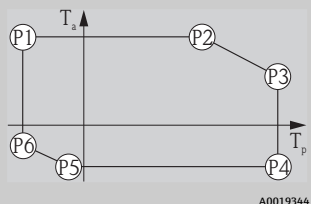

Power Supply; Output (Pos. 2 of the product structure)	P1		P2		P3		P4		P5		P6	
	T _p	T _a	T _p	T _a	T _p	T _a	T _p	T _a	T _p	T _a	T _p	T _a
A	-196 (-321)	81 (178)	81 (178)	81 (178)	280 (536)	46 (115)	280 (536)	-40 (-40) ¹⁾	-40 (-40) ¹⁾	-40 (-40) ¹⁾	-196 (-321)	-4 (25)
B Switch output not used	-196 (-321)	82 (180)	82 (180)	82 (180)	280 (536)	46 (115)	280 (536)	-40 (-40) ¹⁾	-40 (-40) ¹⁾	-40 (-40) ¹⁾	-196 (-321)	-4 (25)
B Switch output used	-196 (-321)	77 (171)	77 (171)	77 (171)	280 (536)	42 (108)	280 (536)	-40 (-40) ¹⁾	-40 (-40) ¹⁾	-40 (-40) ¹⁾	-196 (-321)	-4 (25)
C Channel 2 not used	-196 (-321)	82 (180)	82 (180)	82 (180)	280 (536)	46 (115)	280 (536)	-40 (-40) ¹⁾	-40 (-40) ¹⁾	-40 (-40) ¹⁾	-196 (-321)	-4 (25)
C Channel 2 used	-196 (-321)	79 (174)	79 (174)	79 (174)	280 (536)	44 (111)	280 (536)	-40 (-40) ¹⁾	-40 (-40) ¹⁾	-40 (-40) ¹⁾	-196 (-321)	-4 (25)
E, G Switch output not used	-196 (-321)	83 (181)	83 (181)	83 (181)	280 (536)	46 (115)	280 (536)	-40 (-40) ¹⁾	-40 (-40) ¹⁾	-40 (-40) ¹⁾	-196 (-321)	-4 (25)
E, G Switch output used	-196 (-321)	78 (172)	78 (172)	78 (172)	280 (536)	44 (111)	280 (536)	-40 (-40) ¹⁾	-40 (-40) ¹⁾	-40 (-40) ¹⁾	-196 (-321)	-4 (25)
K, L	-196 (-321)	77 (171)	77 (171)	77 (171)	280 (536)	43 (109)	280 (536)	-40 (-40) ¹⁾	-40 (-40) ¹⁾	-40 (-40) ¹⁾	-196 (-321)	-4 (25)

1) -50 °C (-58 °F) for ordering feature 580 ("Test, Certificate") = JN ("Ambient temperature transmitter -50°C/-58°F")

FMR54
Horn antenna
Seal: Graphite -196 to 280 °C (-321 to 536 °F)
Housing: GT19 (Plastics PBT)
Temperature unit: °C (°F)



A0019344

Power Supply; Output (Pos. 2 of the product structure)	P1		P2		P3		P4		P5		P6	
	T _p	T _a	T _p	T _a	T _p	T _a	T _p	T _a	T _p	T _a	T _p	T _a
A	-196 (-321)	80 (176)	80 (176)	80 (176)	280 (536)	13 (55)	280 (536)	-40 (-40)	-40 (-40)	-40 (-40)	-196 (-321)	18 (64)
B Switch output not used	-196 (-321)	76 (169)	76 (169)	76 (169)	280 (536)	13 (55)	280 (536)	-40 (-40)	-40 (-40)	-40 (-40)	-196 (-321)	18 (64)
B Switch output used	-196 (-321)	60 (140)	60 (140)	60 (140)	280 (536)	13 (55)	280 (536)	-40 (-40)	-40 (-40)	-40 (-40)	-196 (-321)	18 (64)
C Channel 2 not used	-196 (-321)	82 (180)	82 (180)	82 (180)	280 (536)	13 (55)	280 (536)	-40 (-40)	-40 (-40)	-40 (-40)	-196 (-321)	18 (64)
C Channel 2 used	-196 (-321)	74 (165)	74 (165)	74 (165)	280 (536)	13 (55)	280 (536)	-40 (-40)	-40 (-40)	-40 (-40)	-196 (-321)	18 (64)
E, G Switch output not used	-196 (-321)	79 (174)	79 (174)	79 (174)	280 (536)	13 (55)	280 (536)	-40 (-40)	-40 (-40)	-40 (-40)	-196 (-321)	18 (64)
E, G Switch output used	-196 (-321)	63 (145)	63 (145)	63 (145)	280 (536)	13 (55)	280 (536)	-40 (-40)	-40 (-40)	-40 (-40)	-196 (-321)	18 (64)

FMR54
Horn antenna
Seal: Graphite -196 to 280 °C (-321 to 536 °F)
Housing: GT20 (Alu, coated)
Temperature unit: °C (°F)

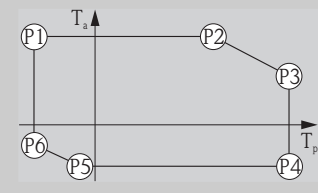

A0019344

Power Supply; Output (Pos. 2 of the product structure)	P1		P2		P3		P4		P5		P6	
	T _p	T _a	T _p	T _a	T _p	T _a	T _p	T _a	T _p	T _a	T _p	T _a
A	-196 (-321)	81 (178)	81 (178)	81 (178)	280 (536)	54 (129)	280 (536)	-40 (-40) ¹⁾	-40 (-40) ¹⁾	-40 (-40) ¹⁾	-196 (-321)	-15 (+5)
B Switch output not used	-196 (-321)	82 (180)	82 (180)	82 (180)	280 (536)	54 (129)	280 (536)	-40 (-40) ¹⁾	-40 (-40) ¹⁾	-40 (-40) ¹⁾	-196 (-321)	-15 (+5)
B Switch output used	-196 (-321)	77 (171)	77 (171)	77 (171)	280 (536)	49 (120)	280 (536)	-40 (-40) ¹⁾	-40 (-40) ¹⁾	-40 (-40) ¹⁾	-196 (-321)	-15 (+5)
C Channel 2 not used	-196 (-321)	82 (180)	82 (180)	82 (180)	280 (536)	54 (129)	280 (536)	-40 (-40) ¹⁾	-40 (-40) ¹⁾	-40 (-40) ¹⁾	-196 (-321)	-15 (+5)
C Channel 2 used	-196 (-321)	79 (174)	79 (174)	79 (174)	280 (536)	51 (124)	280 (536)	-40 (-40) ¹⁾	-40 (-40) ¹⁾	-40 (-40) ¹⁾	-196 (-321)	-15 (+5)
E, G Switch output not used	-196 (-321)	83 (181)	83 (181)	83 (181)	280 (536)	54 (129)	280 (536)	-40 (-40) ¹⁾	-40 (-40) ¹⁾	-40 (-40) ¹⁾	-196 (-321)	-15 (+5)
E, G Switch output used	-196 (-321)	78 (172)	78 (172)	78 (172)	280 (536)	50 (122)	280 (536)	-40 (-40) ¹⁾	-40 (-40) ¹⁾	-40 (-40) ¹⁾	-196 (-321)	-15 (+5)
K, L	-196 (-321)	77 (171)	77 (171)	77 (171)	280 (536)	50 (122)	280 (536)	-40 (-40) ¹⁾	-40 (-40) ¹⁾	-40 (-40) ¹⁾	-196 (-321)	-15 (+5)

1) -50 °C (-58 °F) for ordering feature 580 ("Test, Certificate") = JN ("Ambient temperature transmitter -50°C/-58°F")

FMR54
Horn antenna
Seal: Graphite -196 to 400 °C (-321 to 752 °F)
Housing: GT18 (316 L)
Temperature unit: °C (°F)

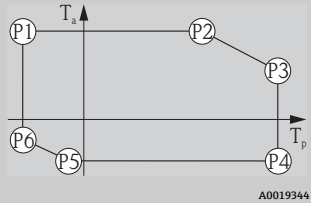

Power Supply; Output (Pos. 2 of the product structure)	P1		P2		P3		P4		P5		P6	
	T _p	T _a	T _p	T _a	T _p	T _a	T _p	T _a	T _p	T _a	T _p	T _a
A	-196 (-321)	81 (178)	81 (178)	81 (178)	400 (752)	31 (88)	400 (752)	-40 (-40) ¹⁾	-40 (-40) ¹⁾	-40 (-40) ¹⁾	-196 (-321)	-13 (+9)
B Switch output not used	-196 (-321)	82 (180)	82 (180)	82 (180)	400 (752)	31 (88)	400 (752)	-40 (-40) ¹⁾	-40 (-40) ¹⁾	-40 (-40) ¹⁾	-196 (-321)	-13 (+9)
B Switch output used	-196 (-321)	77 (171)	77 (171)	77 (171)	400 (752)	29 (84)	400 (752)	-40 (-40) ¹⁾	-40 (-40) ¹⁾	-40 (-40) ¹⁾	-196 (-321)	-13 (+9)
C Channel 2 not used	-196 (-321)	82 (180)	82 (180)	82 (180)	400 (752)	31 (88)	400 (752)	-40 (-40) ¹⁾	-40 (-40) ¹⁾	-40 (-40) ¹⁾	-196 (-321)	-13 (+9)
C Channel 2 used	-196 (-321)	79 (174)	79 (174)	79 (174)	400 (752)	31 (88)	400 (752)	-40 (-40) ¹⁾	-40 (-40) ¹⁾	-40 (-40) ¹⁾	-196 (-321)	-13 (+9)
E, G Switch output not used	-196 (-321)	83 (181)	83 (181)	83 (181)	400 (752)	31 (88)	400 (752)	-40 (-40) ¹⁾	-40 (-40) ¹⁾	-40 (-40) ¹⁾	-196 (-321)	-13 (+9)
E, G Switch output used	-196 (-321)	78 (172)	78 (172)	78 (172)	400 (752)	31 (88)	400 (752)	-40 (-40) ¹⁾	-40 (-40) ¹⁾	-40 (-40) ¹⁾	-196 (-321)	-13 (+9)
K, L	-196 (-321)	77 (171)	77 (171)	77 (171)	400 (752)	30 (86)	400 (752)	-40 (-40) ¹⁾	-40 (-40) ¹⁾	-40 (-40) ¹⁾	-196 (-321)	-13 (+9)

1) -50 °C (-58 °F) for ordering feature 580 ("Test, Certificate") = JN ("Ambient temperature transmitter -50°C/-58°F")

FMR54
Horn antenna
Seal: Graphite -196 to 400 °C (-321 to 752 °F)
Housing: GT19 (Plastics PBT)
Temperature unit: °C (°F)

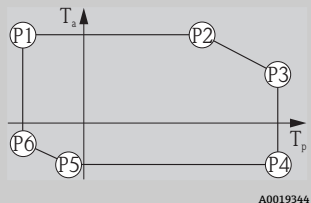

Power Supply; Output (Pos. 2 of the product structure)	P1		P2		P3		P4		P5		P6	
	T _p	T _a	T _p	T _a	T _p	T _a	T _p	T _a	T _p	T _a	T _p	T _a
A	-196 (-321)	80 (176)	80 (176)	80 (176)	400 (752)	-19 (-2)	400 (752)	-40 (-40)	-40 (-40)	-40 (-40)	-196 (-321)	11 (52)
B Switch output not used	-196 (-321)	76 (169)	76 (169)	76 (169)	400 (752)	-19 (-2)	400 (752)	-40 (-40)	-40 (-40)	-40 (-40)	-196 (-321)	11 (52)
B Switch output used	-196 (-321)	60 (140)	60 (140)	60 (140)	400 (752)	-19 (-2)	400 (752)	-40 (-40)	-40 (-40)	-40 (-40)	-196 (-321)	11 (52)
C Channel 2 not used	-196 (-321)	82 (180)	82 (180)	82 (180)	400 (752)	-19 (-2)	400 (752)	-40 (-40)	-40 (-40)	-40 (-40)	-196 (-321)	11 (52)
C Channel 2 used	-196 (-321)	74 (165)	74 (165)	74 (165)	400 (752)	-19 (-2)	400 (752)	-40 (-40)	-40 (-40)	-40 (-40)	-196 (-321)	11 (52)
E, G Switch output not used	-196 (-321)	79 (174)	79 (174)	79 (174)	400 (752)	-19 (-2)	400 (752)	-40 (-40)	-40 (-40)	-40 (-40)	-196 (-321)	11 (52)
E, G Switch output used	-196 (-321)	63 (145)	63 (145)	63 (145)	400 (752)	-19 (-2)	400 (752)	-40 (-40)	-40 (-40)	-40 (-40)	-196 (-321)	11 (52)

FMR54
Horn antenna
Seal: Graphite -196 to 400 °C (-321 to 752 °F)
Housing: GT20 (Alu, coated)
Temperature unit: °C (°F)

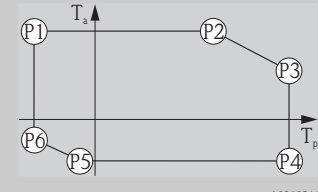

A0019344

Power Supply; Output (Pos. 2 of the product structure)	P1		P2		P3		P4		P5		P6	
	T _p	T _a	T _p	T _a	T _p	T _a	T _p	T _a	T _p	T _a	T _p	T _a
A	-196 (-321)	81 (178)	81 (178)	81 (178)	400 (752)	42 (108)	400 (752)	-40 (-40) ¹⁾	-40 (-40) ¹⁾	-40 (-40) ¹⁾	-196 (-321)	-19 (-2) ²⁾
B Switch output not used	-196 (-321)	82 (180)	82 (180)	82 (180)	400 (752)	42 (108)	400 (752)	-40 (-40) ¹⁾	-40 (-40) ¹⁾	-40 (-40) ¹⁾	-196 (-321)	-19 (-2) ²⁾
B Switch output used	-196 (-321)	77 (171)	77 (171)	77 (171)	400 (752)	39 (102)	400 (752)	-40 (-40) ¹⁾	-40 (-40) ¹⁾	-40 (-40) ¹⁾	-196 (-321)	-19 (-2) ²⁾
C Channel 2 not used	-196 (-321)	82 (180)	82 (180)	82 (180)	400 (752)	42 (108)	400 (752)	-40 (-40) ¹⁾	-40 (-40) ¹⁾	-40 (-40) ¹⁾	-196 (-321)	-19 (-2) ²⁾
C Channel 2 used	-196 (-321)	79 (174)	79 (174)	79 (174)	400 (752)	41 (106)	400 (752)	-40 (-40) ¹⁾	-40 (-40) ¹⁾	-40 (-40) ¹⁾	-196 (-321)	-19 (-2) ²⁾
E, G Switch output not used	-196 (-321)	83 (181)	83 (181)	83 (181)	400 (752)	42 (108)	400 (752)	-40 (-40) ¹⁾	-40 (-40) ¹⁾	-40 (-40) ¹⁾	-196 (-321)	-19 (-2) ²⁾
E, G Switch output used	-196 (-321)	78 (172)	78 (172)	78 (172)	400 (752)	40 (104)	400 (752)	-40 (-40) ¹⁾	-40 (-40) ¹⁾	-40 (-40) ¹⁾	-196 (-321)	-19 (-2) ²⁾
K, L	-196 (-321)	77 (171)	77 (171)	77 (171)	400 (752)	40 (104)	400 (752)	-40 (-40) ¹⁾	-40 (-40) ¹⁾	-40 (-40) ¹⁾	-196 (-321)	-19 (-2) ²⁾

- 1) -50 °C (-58 °F) for ordering feature 580 ("Test, Certificate") = JN ("Ambient temperature transmitter -50°C/-58°F")
 2) -26 °C (-15 °F) for ordering feature 580 ("Test, Certificate") = JN ("Ambient temperature transmitter -50°C/-58°F")

FMR54
Planar antenna
Housing: GT18 (316 L)
Temperature unit: °C (°F)

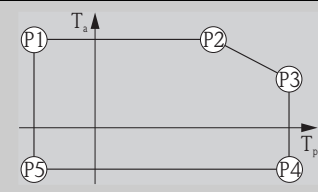

A0019351

Power Supply; Output (Pos. 2 of the product structure)	P1		P2		P3		P4		P5		P6	
	T _p	T _a	T _p	T _a	T _p	T _a	T _p	T _a	T _p	T _a	T _p	T _a
A	-40 (-40)	81 (178)	81 (178)	81 (178)	150 (302)	69 (156)	150 (302)	-40 (-40)	-40 (-40)	-40 (-40)	-	-
B Switch output not used	-40 (-40)	82 (180)	82 (180)	82 (180)	150 (302)	69 (156)	150 (302)	-40 (-40)	-40 (-40)	-40 (-40)	-	-
B Switch output used	-40 (-40)	77 (171)	77 (171)	77 (171)	150 (302)	63 (145)	150 (302)	-40 (-40)	-40 (-40)	-40 (-40)	-	-
C Channel 2 not used	-40 (-40)	82 (180)	82 (180)	82 (180)	150 (302)	70 (158)	150 (302)	-40 (-40)	-40 (-40)	-40 (-40)	-	-
C Channel 2 used	-40 (-40)	79 (174)	79 (174)	79 (174)	150 (302)	66 (151)	150 (302)	-40 (-40)	-40 (-40)	-40 (-40)	-	-
E, G Switch output not used	-40 (-40)	83 (181)	83 (181)	83 (181)	150 (302)	71 (160)	150 (302)	-40 (-40)	-40 (-40)	-40 (-40)	-	-
E, G Switch output used	-40 (-40)	78 (172)	78 (172)	78 (172)	150 (302)	65 (149)	150 (302)	-40 (-40)	-40 (-40)	-40 (-40)	-	-
K, L	-40 (-40)	77 (171)	77 (171)	77 (171)	150 (302)	64 (147)	150 (302)	-40 (-40)	-40 (-40)	-40 (-40)	-	-

FMR54
Planar antenna
Housing: GT19 (Plastics PBT)
Temperature unit: °C (°F)

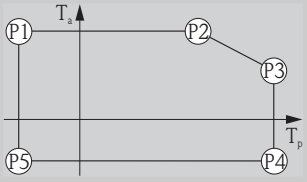

Power Supply; Output (Pos. 2 of the product structure)	P1		P2		P3		P4		P5		P6	
	T _p	T _a	T _p	T _a	T _p	T _a	T _p	T _a	T _p	T _a	T _p	T _a
A	-40 (-40)	80 (176)	80 (176)	80 (176)	150 (302)	60 (140)	150 (302)	-40 (-40)	-40 (-40)	-40 (-40)	-	-
B Switch output not used	-40 (-40)	76 (169)	76 (169)	76 (169)	150 (302)	60 (140)	150 (302)	-40 (-40)	-40 (-40)	-40 (-40)	-	-
B Switch output used	-40 (-40)	60 (140)	60 (140)	60 (140)	150 (302)	41 (106)	150 (302)	-40 (-40)	-40 (-40)	-40 (-40)	-	-
C Channel 2 not used	-40 (-40)	82 (180)	82 (180)	82 (180)	150 (302)	60 (140)	150 (302)	-40 (-40)	-40 (-40)	-40 (-40)	-	-
C Channel 2 used	-40 (-40)	74 (165)	74 (165)	74 (165)	150 (302)	57 (135)	150 (302)	-40 (-40)	-40 (-40)	-40 (-40)	-	-
E, G Switch output not used	-40 (-40)	79 (174)	79 (174)	79 (174)	150 (302)	60 (140)	150 (302)	-40 (-40)	-40 (-40)	-40 (-40)	-	-
E, G Switch output used	-40 (-40)	63 (145)	63 (145)	63 (145)	150 (302)	44 (111)	150 (302)	-40 (-40)	-40 (-40)	-40 (-40)	-	-

FMR54
Planar antenna
Housing: GT20 (Alu, coated)
Temperature unit: °C (°F)

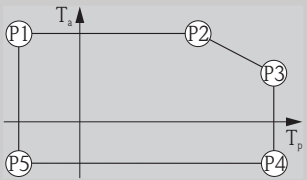

Power Supply; Output (Pos. 2 of the product structure)	P1		P2		P3		P4		P5		P6	
	T _p	T _a	T _p	T _a	T _p	T _a	T _p	T _a	T _p	T _a	T _p	T _a
A	-40 (-40)	81 (178)	81 (178)	81 (178)	150 (302)	71 (160)	150 (302)	-40 (-40)	-40 (-40)	-40 (-40)	-	-
B Switch output not used	-40 (-40)	82 (180)	82 (180)	82 (180)	150 (302)	72 (162)	150 (302)	-40 (-40)	-40 (-40)	-40 (-40)	-	-
B Switch output used	-40 (-40)	77 (171)	77 (171)	77 (171)	150 (302)	66 (151)	150 (302)	-40 (-40)	-40 (-40)	-40 (-40)	-	-
C Channel 2 not used	-40 (-40)	82 (180)	82 (180)	82 (180)	150 (302)	72 (162)	150 (302)	-40 (-40)	-40 (-40)	-40 (-40)	-	-
C Channel 2 used	-40 (-40)	79 (174)	79 (174)	79 (174)	150 (302)	68 (154)	150 (302)	-40 (-40)	-40 (-40)	-40 (-40)	-	-
E, G Switch output not used	-40 (-40)	83 (181)	83 (181)	83 (181)	150 (302)	73 (163)	150 (302)	-40 (-40)	-40 (-40)	-40 (-40)	-	-
E, G Switch output used	-40 (-40)	78 (172)	78 (172)	78 (172)	150 (302)	68 (154)	150 (302)	-40 (-40)	-40 (-40)	-40 (-40)	-	-
K, L	-40 (-40)	77 (171)	77 (171)	77 (171)	150 (302)	67 (153)	150 (302)	-40 (-40)	-40 (-40)	-40 (-40)	-	-

Storage temperature -40 to +80 °C (-40 to +176 °F)
 -50 °C (-58 °F) with manufacturer declaration on request

Climate class DIN EN 60068-2-38 (test Z/AD)

Altitude according to IEC61010-1 Ed.3	<ul style="list-style-type: none"> ■ Generally up to 2 000 m (6 600 ft) above MSL. ■ Above 2 000 m (6 600 ft) if the following conditions are met: <ul style="list-style-type: none"> - Ordering feature 020 "Power supply; Output" = A, B, C, E or G (2-wire versions) - Supply voltage $U < 35\text{ V}$ - Supply voltage of overvoltage category 1
Degree of protection	<ul style="list-style-type: none"> ■ With closed housing tested according to: <ul style="list-style-type: none"> - IP68, NEMA6P (24 h at 1.83 m under water surface) - For plastic housing with transparent cover (display module): IP68 (24 h at 1.00 m under water surface)⁵⁾ - IP66, NEMA4X ■ With open housing: IP20, NEMA1 ■ Display module: IP22, NEMA2 <p> Degree of protection IP68 NEMA6P applies for M12 PROFIBUS PA plugs only when the PROFIBUS cable is plugged in and is also rated IP68 NEMA6P.</p>
Vibration resistance	DIN EN 60068-2-64 / IEC 60068-2-64: 20 to 2 000 Hz, 1 (m/s ²) ² /Hz
Cleaning the antenna	<p>The antenna can get contaminated, depending on the application. The emission and reception of microwaves can thus eventually be hindered. The degree of contamination leading to an error depends on the medium and the reflectivity, mainly determined by the dielectric constant ϵ_r.</p> <p>If the medium tends to cause contamination and deposits, cleaning on a regular basis is recommended. Care has to be taken not to damage the antenna in the process of a mechanical or hose-down cleaning. The material compatibility has to be considered if cleaning agents are used! The maximum permitted temperature at the flange should not be exceeded.</p>
Electromagnetic compatibility (EMC)	<p>Electromagnetic compatibility to all relevant requirements of the EN 61326- series and NAMUR recommendation EMC (NE21). For details see declaration of conformity.⁶⁾</p> <p>If only the analogue signal is used, unshielded interconnection lines are sufficient for the installation. In case of using the digital signal (HART/ PA/ FF) use shielded interconnection lines.</p> <p>Max. fluctuations during EMC- tests: < 0.5 % of the span. As an exception to this, the maximum fluctuations may amount to 2 % of the span for devices with plastic housing and see-through lid (integrated display SD02 or SD03) if strong electromagnetic interferences in the frequency range of 1 to 2 GHz are present.</p>

5) This restriction is valid if the following options of the product structure have been selected at the same time: 030 ("Display, Operation") = C ("SD02") or E ("SD03"); 040 ("Housing") = A ("GT19").

6) Can be downloaded from www.endress.com.

Process

Process temperature, Process pressure



The specified pressure range may be reduced due to the selected process connection. The pressure rating (PN) specified on the flanges refers to a reference temperature of 20 °C, for ASME flanges 100 °F. Pay attention to pressure-temperature dependencies.

Please refer to the following standards for the pressure values permitted for higher temperatures:

- EN 1092-1: 2001 Tab. 18

With regard to their temperature stability properties, the materials 1.4435 and 1.4404 are grouped under 13E0 in EN 1092-1 Tab. 18. The chemical composition of the two materials can be identical.

- ASME B 16.5a - 1998 Tab. 2-2.2 F316
- ASME B 16.5a - 1998 Tab. 2.3.8 N10276
- JIS B 2220

FMR53

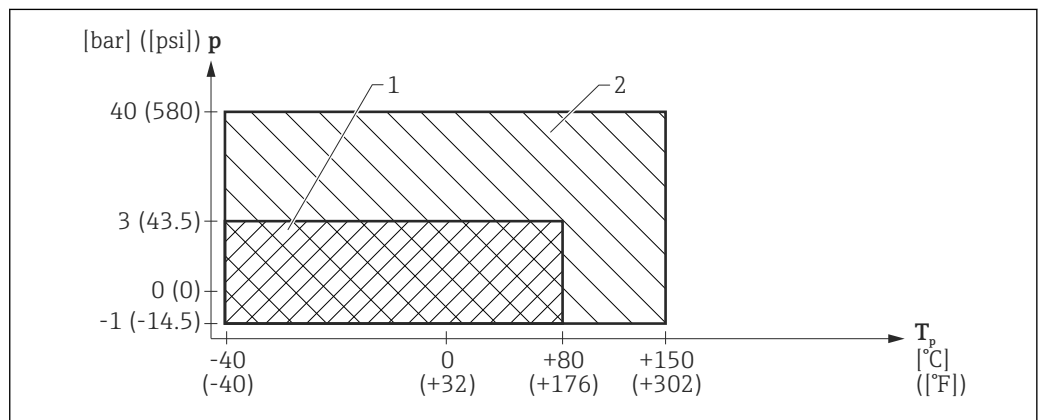

A0023251-EN

21 FMR53: Admissible range of process temperature and process pressure

- Process connection: Thread PVDF
- Any other process connection (thread 316L, flange)

Feature 100 "Process connection"	Admissible process temperature	Admissible process pressure
<ul style="list-style-type: none"> RGF: Thread ANSI MNPT1-1/2, PVDF RVF: Thread EN10226 R1-1/2, PVDF 	-40 to +80 °C (-40 to +176 °F)	$p_{rel} = -1$ to 3 bar (-14.5 to 43.5 psi) $p_{abs} < 4$ bar (58 psi)
Any other process connection	-40 to +150 °C (-40 to +302 °F)	$p_{rel} = -1$ to 40 bar (-14.5 to 580 psi)

FMR54

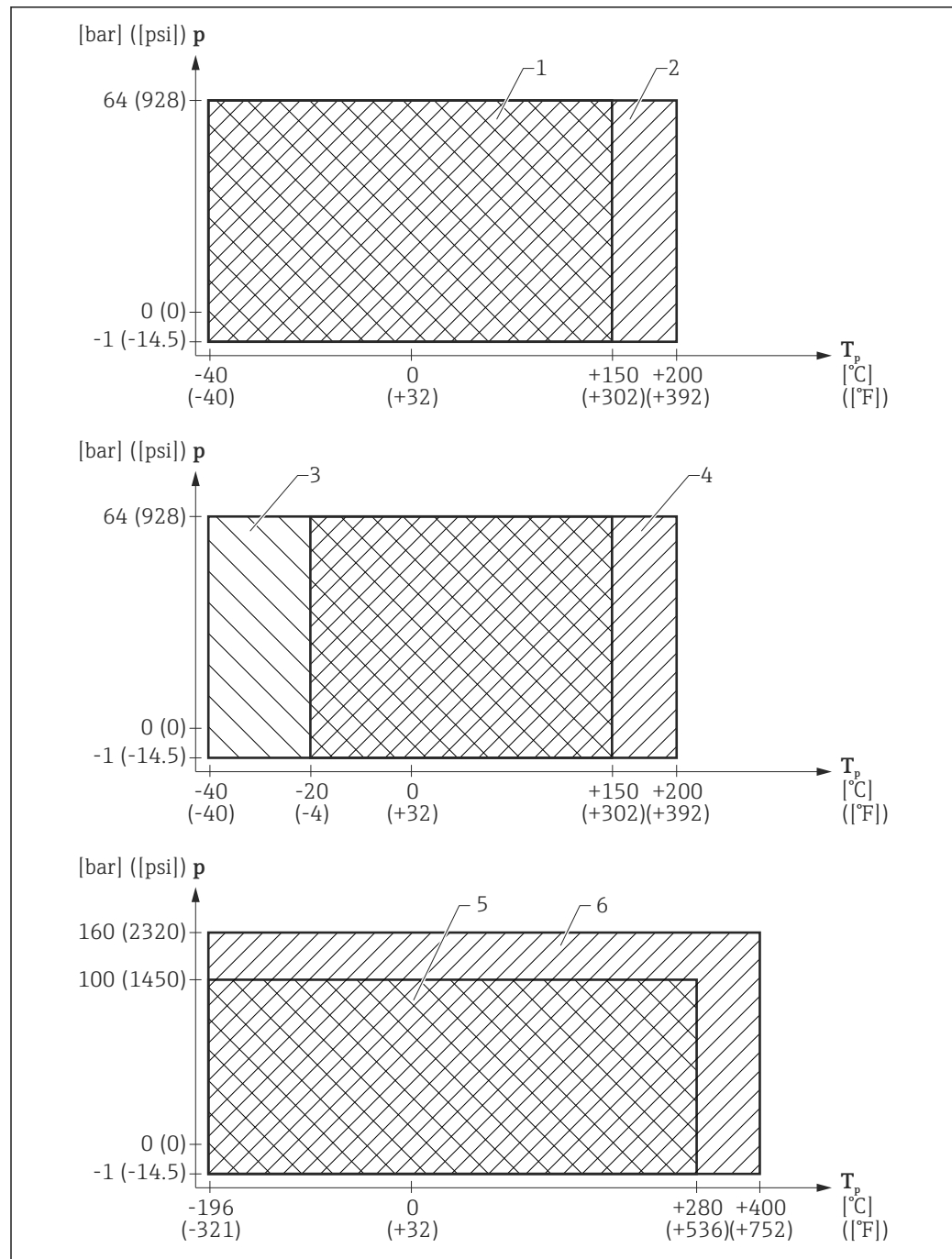

22 FMR54 with horn antenna: Admissible range of process temperature and process pressure

- 1 Seal: Viton (Feature 090 "Seal", Option A8); valid for conductive media
- 2 Seal: Viton (Feature 090 "Seal", Option A8); enlarged area for non-conductive media
- 3 Seal: EPDM (Feature 090 "Seal", Option B4)
- 4 Seal: Kalrez
- 5 Seal: Graphite (XT) (Feature 090 "Seal", Option D1)
- 6 Seal: Graphite (HT) (Feature 090 "Seal", Option D2)

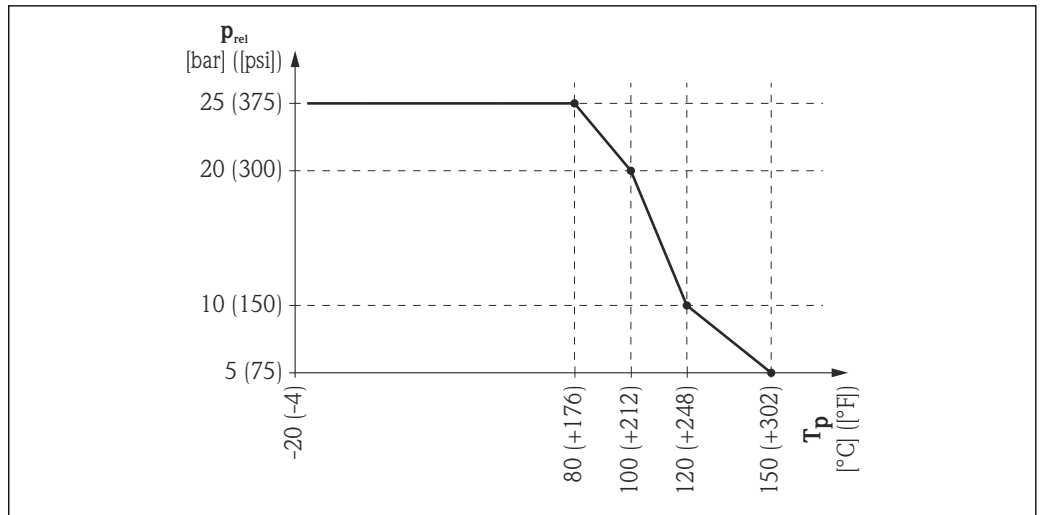

A0020552-EN

23 FMR54 with planar antenna: Admissible range of process temperature and process pressure

Feature 070 "Antenna"	Feature 090 "Seal"	Admissible process temperature	Admissible process pressure
<ul style="list-style-type: none"> AA: W/o horn, for pipe installation BC: Horn 80mm/3" BD: Horn 100mm/4" BE: Horn 150mm/6" BF: Horn 200mm/8" BG: Horn 250mm/10" 	A8: Viton	<ul style="list-style-type: none"> conductive media: -40 to +150 °C (-40 to +302 °F) non-conductive media: -40 to +200 °C (-40 to +392 °F) 	-1 to 64 bar (-14.5 to 928 psi)
	B4: EPDM	-40 to +150 °C (-40 to +302 °F)	
	C2: Kalrez	-20 to +200 °C (-4 to +392 °F)	
	D1: Graphite (XT)	-196 to +280 °C (-321 to +536 °F)	-1 to 100 bar (-14.5 to 1450 psi) ¹⁾
	D2: Graphite (HT)	-196 to +400 °C (-321 to +752 °F)	-1 to 160 bar (-14.5 to 2320 psi) ¹⁾
<ul style="list-style-type: none"> DA: Planar 150mm/6" DB: Planar 200mm/8" DC: Planar 250mm/10" DD: Planar 300mm/12" 	A7: Viton	-20 to +150 °C (-4 to +302 °F)	Dependent on the process temperature, $T_{p,i}$; see the diagram above

1) For devices with CRN approval the pressure range may be reduced → 90

Dielectric constant

- For liquids
 - $\epsilon_r \geq 1.9$ in free-field applications
 - $\epsilon_r \geq 1.4$ in stilling well

- For bulk solids
 - $\epsilon_r \geq 1.6$

i For dielectric constants (DC values) of many media commonly used in various industries refer to:

- the Endress+Hauser DC manual (CP01076F)
- the Endress+Hauser "DC Values App" (available for Android and iOS)

Mechanical construction

Dimensions

Dimensions of the electronics housing

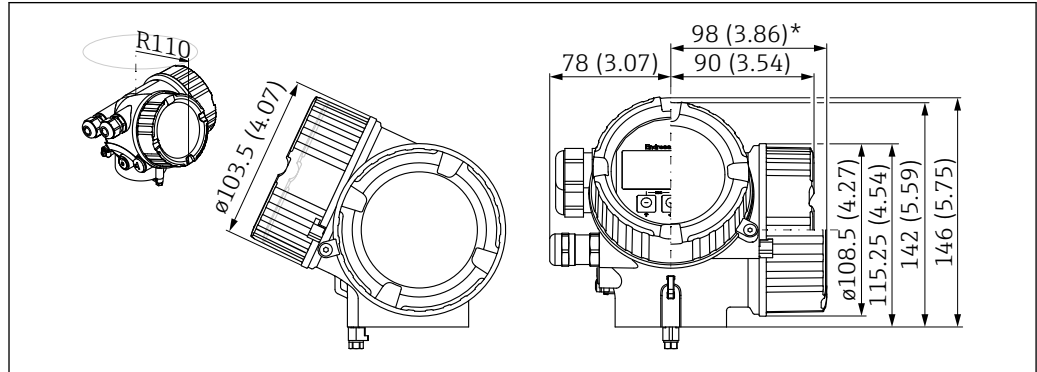

A0011666

24 Housing GT18 (316L); Dimensions in mm (in)
*for devices with integrated overvoltage protection.

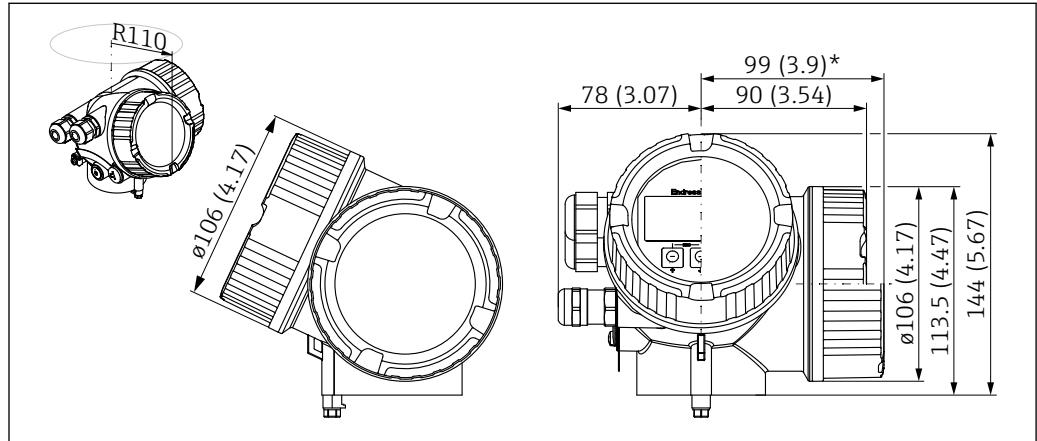

A0011346

25 Housing GT19 (Plastics PBT); Dimensions in mm (in)
*for devices with integrated overvoltage protection.

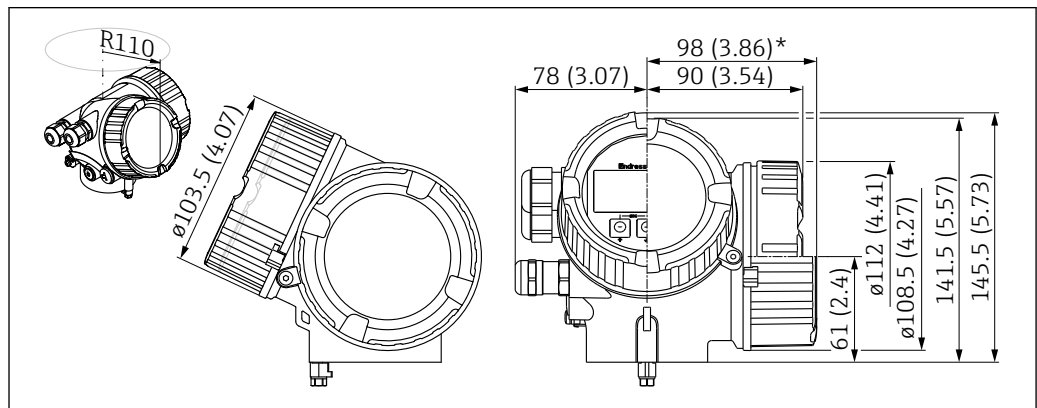

A0020751

26 Housing GT20 (Alu coated); Dimensions in mm (in)
*for devices with integrated overvoltage protection.

FMR53 with flange

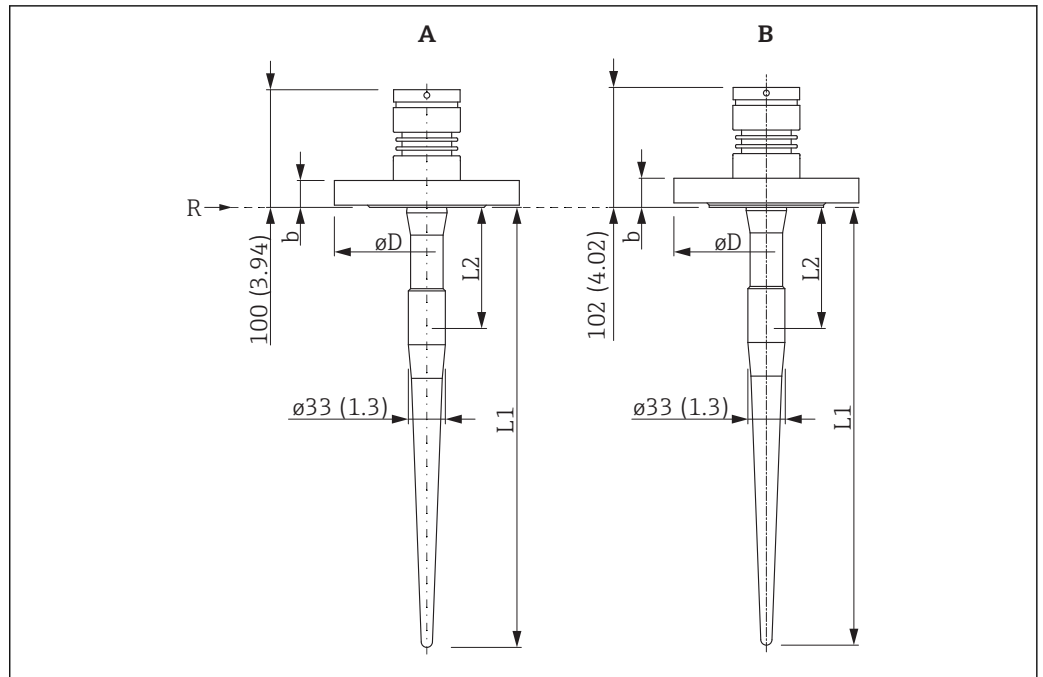

A0023390

27 FMR53 with flange; dimensions: mm (in)

- A Process connection: Flange 316/316L (without cladding)
- B Process connection: Flange PTFE>316L (cladded)
- R Reference point of the measurement

Feature 070 "Antenna"	Antenna length L1	Inactive length L2
CA: Rod 390mm/15"	390 mm (15.4 in)	100 mm (3.94 in)
CB: Rod 540mm/21"	540 mm (21.3 in)	250 mm (9.84 in)

Flanges according to EN1092-1 (suitable for DIN2527)

Pressure rating	Dimension	Nominal diameter			
		DN50	DN80	DN100	DN150
PN10/16	b	18 mm (0.71 in)	20 mm (0.79 in)	20 mm (0.79 in)	22 mm (0.87 in)
	øD	ø165 mm (6.5 in)	ø200 mm (7.87 in)	ø220 mm (8.66 in)	ø285 mm (11.2 in)
PN25/40	b	-	24 mm (0.94 in)	-	-
	øD	-	ø200 mm (7.87 in)	-	-

Flanges according to ANSI B16.5

Pressure rating	Dimension	Nominal diameter			
		2"	3"	4"	6"
150 lbs	b	17.5 mm (0.69 in)	22.3 mm (0.88 in)	22.3 mm (0.88 in)	23.9 mm (0.94 in)
	øD	ø150 mm (6 in)	ø190 mm (7.5 in)	ø230 mm (9 in)	ø280 mm (11 in)
300 lbs	b	-	27 mm (1.1 in)	30.2 mm (1.19 in)	-
	øD	-	ø210 mm (8.25 in)	ø255 mm (10 in)	-

Flanges according to JIS B2220

Pressure rating	Dimension	Nominal diameter			
		50A	80A	100A	150A
10 K	b	16 mm (0.63 in)	18 mm (0.71 in)	18 mm (0.71 in)	22 mm (0.87 in)
	ϕD	$\phi 155$ mm (6.1 in)	$\phi 185$ mm (7.28 in)	$\phi 210$ mm (8.27 in)	$\phi 280$ mm (11 in)

FMR53 with thread

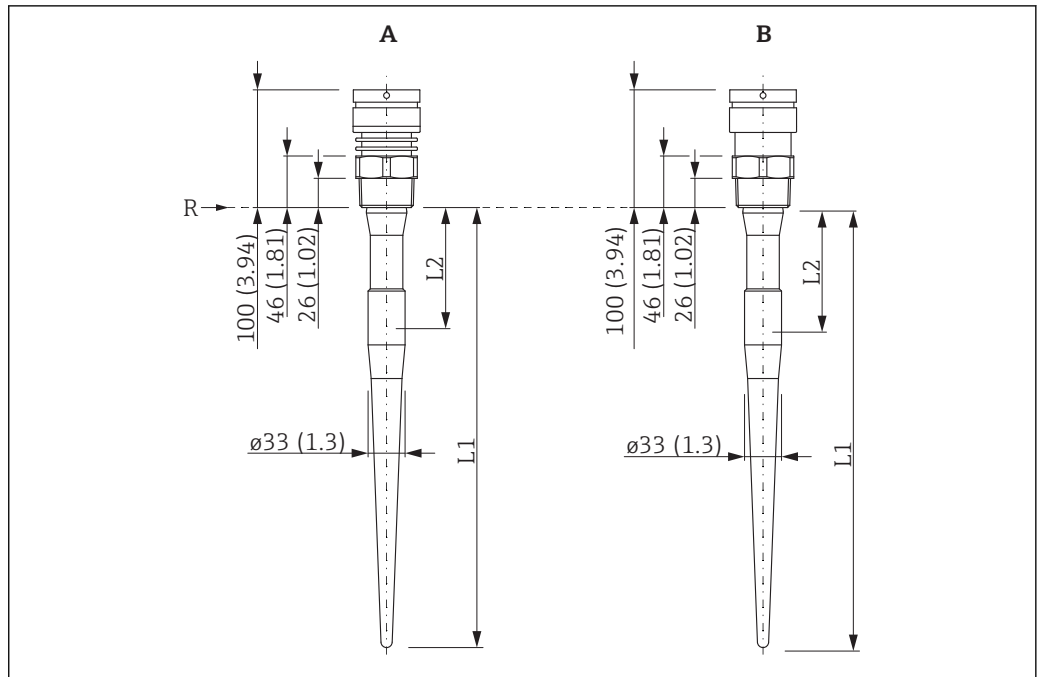

A0023991

28 FMR53 with thread; dimensions: mm (in)

- A Process connection: Thread 316L
- B Process connection: Thread PVDF
- R Reference point of the measurement

Feature 070 "Antenna"	Antenna length L1	Inactive length L2
CA: Rod 390mm/15"	390 mm (15.4 in)	100 mm (3.94 in)
CB: Rod 540mm/21"	540 mm (21.3 in)	250 mm (9.84 in)

FMR54 with horn antenna

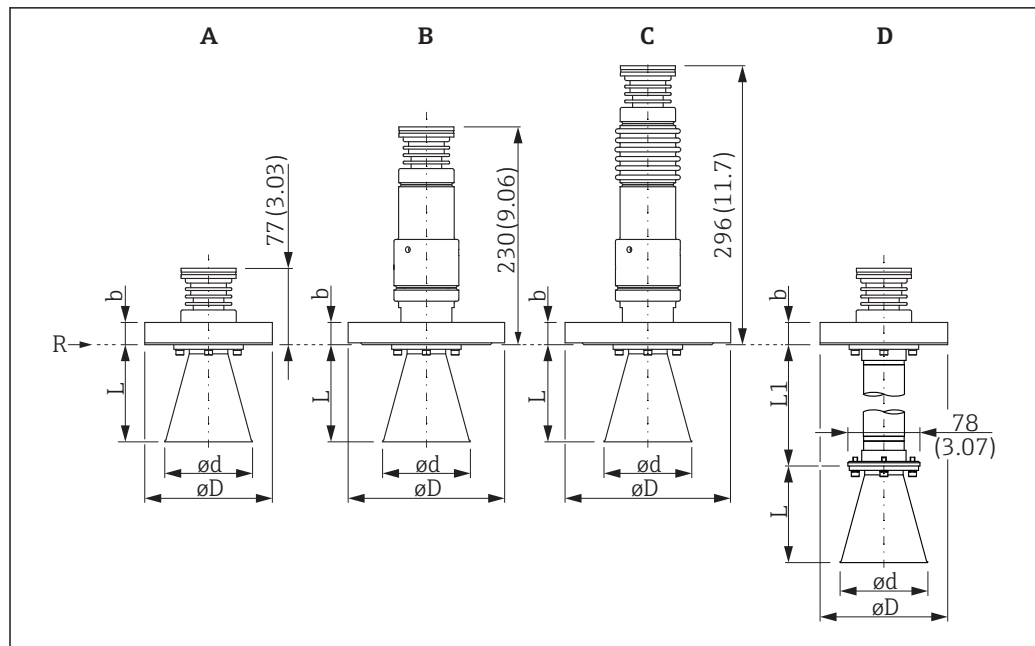

A0017809

29 FMR54 with horn antenna; dimensions: mm (in)

- A Seal: Viton/EPDM/Kalrez
- B Seal: Graphite, -196...280°C/-321...536°F (XT)
- C Seal: Graphite, -196...400°C/-321...752°F (HT)
- D Antenna extension; optionally available for all horn antennas
- R Reference point of the measurement

Feature 070 "Antenna"					
Dimension	BC: Horn 80mm/3"	BD: Horn 100mm/4"	BE: Horn 150mm/6"	BF: Horn 200mm/8"	BG: Horn 250mm/10"
L	68 mm (2.68 in)	105 mm (4.13 in)	185 mm (7.28 in)	268 mm (10.6 in)	360 mm (14.2 in)
ød	ø75 mm (2.95 in)	ø95 mm (3.74 in)	ø145 mm (5.71 in)	ø190 mm (7.48 in)	ø240 mm (9.45 in)
L1	100 mm (3.94 in) / 200 mm (7.87 in) / 300 mm (11.8 in) / 400 mm (15.7 in)				

Flanges according to EN1092-1 (suitable for DIN2527) ¹⁾

Pressure rating ²⁾	Dimension	Nominal diameter ²⁾				
		DN80	DN100	DN150	DN200	DN250
PN10/16	b	20 mm (0.79 in)	20 mm (0.79 in)	22 mm (0.87 in)	24 mm (0.94 in)	26 mm (1.02 in)
	øD	ø200 mm (7.87 in)	ø220 mm (8.66 in)	ø285 mm (11.2 in)	ø340 mm (13.4 in)	ø405 mm (15.9 in)
PN25/40	b	24 mm (0.94 in)	24 mm (0.94 in)	-	-	-
	øD	ø200 mm (7.87 in)	ø235 mm (9.25 in)	-	-	-

1) For flanges with a higher pressure rating than those listed in the product structure please contact Endress +Hauser.

2) Feature 100 of the product structure

Flanges according to ANSI B16.5¹⁾

Pressure rating ¹⁾	Dimension	Nominal diameter ²⁾				
		3"	4"	6"	8"	10"
150 lbs	b	22.3 mm (0.88 in)	22.3 mm (0.88 in)	23.9 mm (0.94 in)	27 mm (1.06 in)	28.6 mm (1.13 in)
	φD	φ190 mm (7.5 in)	φ230 mm (9 in)	φ280 mm (11 in)	φ345 mm (13.5 in)	φ405 mm (16 in)
300 lbs	b	27 mm (1.06 in)	30.2 mm (1.2 in)	-	-	-
	φD	φ210 mm (8.25 in)	φ255 mm (10 in)	-	-	-

- 1) For flanges with a higher pressure rating than those listed in the product structure please contact Endress +Hauser.
- 2) Feature 100 of the product structure

Flanges according to JIS B 2220¹⁾

Pressure rating ¹⁾	Dimensions	Nominal diameter ²⁾				
		DN80	DN100	DN150	DN200	DN250
10 K	b	18 mm (0.71 in)	18 mm (0.71 in)	22 mm (0.87 in)	22 mm (0.87 in)	24 mm (0.94 in)
	φD	φ185 mm (7.28 in)	φ210 mm (8.27 in)	φ280 mm (11 in)	φ330 mm (13 in)	φ400 mm (15.7 in)

- 1) For flanges with a higher pressure rating than those listed in the product structure please contact Endress +Hauser.
- 2) Feature 100 of the product structure

FMR54 with planar antenna

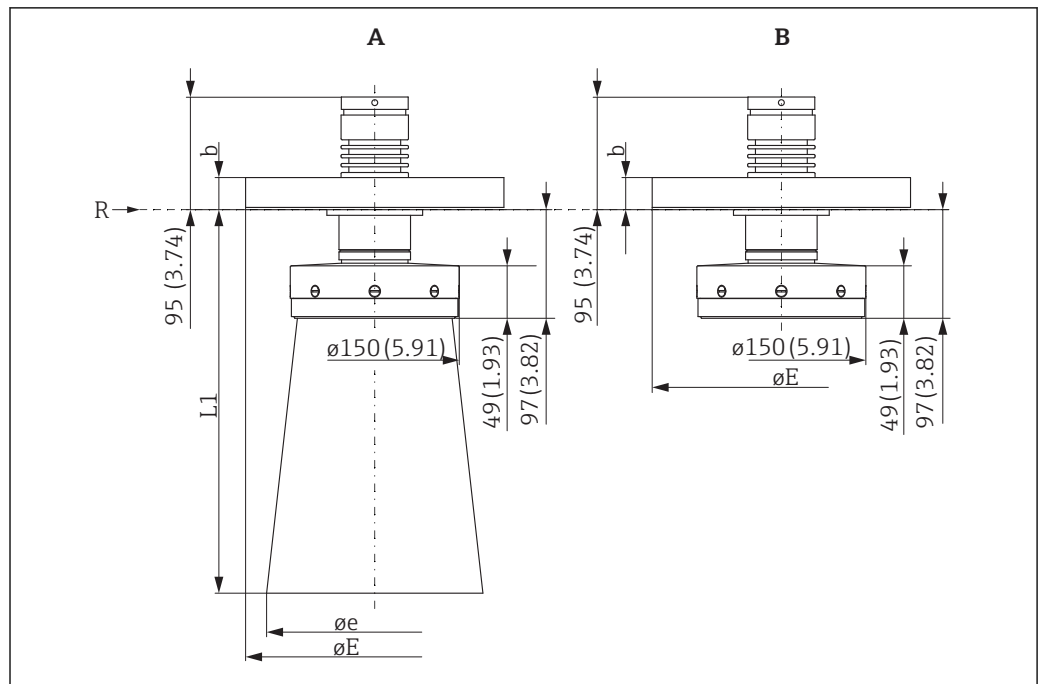

A0017810

- A With antenna extension (for planar antenna 200mm/8" to 300mm/12")
- B Without horn extension (for planar antenna 150mm/6")
- R Reference point of the measurement

Antenna extension

Dimension	Feature 070 "Antenna"		
	DB: Planar 200mm/8"	DC: Planar 250mm/10"	DD: Planar 300mm/12"
e	192 mm (7.56 in)	242 mm (9.53 in)	292 mm (11.5 in)
L1	341 mm (13.4 in)	494 mm (19.4 in)	521 mm (20.5 in)

Flanges according to EN1092-1 (suitable for DIN2527)

Pressure rating ¹⁾	Dimension	Nominal diameter ¹⁾			
		DN150	DN200	DN250	DN300
PN16	b	22 mm (0.87 in)	24 mm (0.94 in)	26 mm (1.02 in)	28 mm (1.1 in)
	øE	ø285 mm (11.2 in)	ø340 mm (13.4 in)	ø405 mm (15.9 in)	ø460 mm (18.1 in)
PN25	b	28 mm (1.1 in)	30 mm (1.18 in)	-	-
	øE	ø300 mm (11.8 in)	ø360 mm (14.2 in)	-	-

1) Feature 100 of the product structure

Flanges according to ANSI B16.5

Pressure rating ¹⁾	Dimension	Nominal diameter ¹⁾			
		6"	8"	10"	12"
150 lbs	b	23.9 mm (0.94 in)	27 mm (1.06 in)	28.6 mm (1.13 in)	30.2 mm (1.19 in)
	øE	ø280 mm (11 in)	ø345 mm (13.5 in)	ø405 mm (16 in)	ø485 mm (19 in)

Pressure rating ¹⁾	Dimension	Nominal diameter ¹⁾			
		6"	8"	10"	12"
300 lbs	b	35 mm (1.38 in)	39.7 mm (1.56 in)	-	-
	∅E	∅320 mm (12.5 in)	∅380 mm (15 in)	-	-

1) Feature 100 of the product structure

Flanges according to JIS B2220

Pressure rating ¹⁾	Dimension	Nominal diameter ¹⁾		
		DN150	DN200	DN250
10 K	b	22 mm (0.87 in)	22 mm (0.87 in)	24 mm (0.94 in)
	∅E	∅280 mm (11 in)	∅330 mm (13 in)	∅400 mm (15.7 in)
20 K	b	28 mm (1.1 in)	30 mm (1.18 in)	-
	∅E	∅305 mm (12 in)	∅350 mm (13.8 in)	-

1) Feature 100 of the product structure

Weight

Housing

Part	Weight
Housing GT18 - stainless steel	approx. 4.5 kg (9.9 lb)
Housing GT19 - plastic	approx. 1.2 kg (2.7 lb)
Housing GT20 - aluminium	approx. 1.9 kg (4.2 lb)

Antenna and process connection

Device	Weight of antenna and process connection
FMR53	max. 3.0 kg (6.6 lb) + weight of flange ¹⁾
FMR54	max. 9 kg (19.9 lb) + weight of flange ¹⁾

1) For the weight of the flange refer to Technical Information TI00426F.

**Materials: GT18 housing
(stainless steel, corrosion-
resistant)**

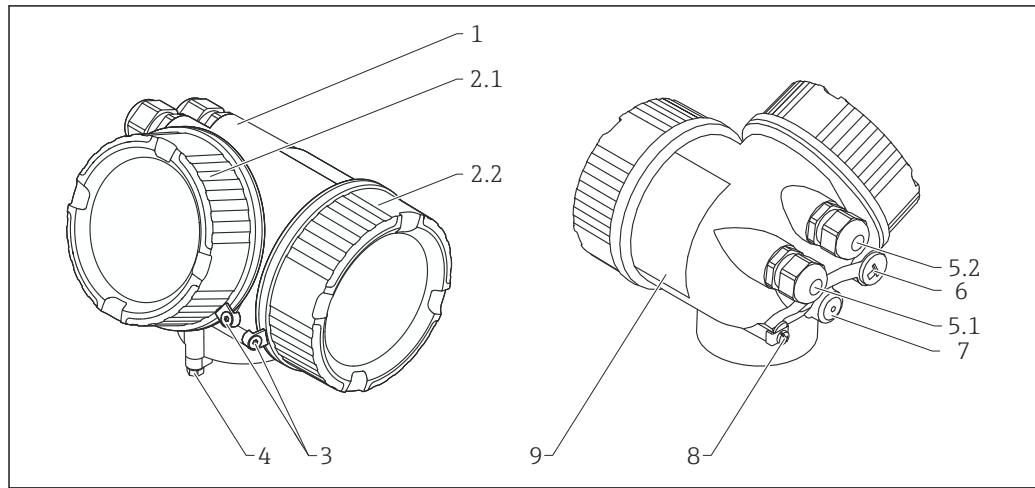

No.	Part	Material
1	Housing	CF3M similar to 316L/1.4404
2.1	Cover of the electronics compartment	<ul style="list-style-type: none"> ▪ Cover: CF3M (similar to 316L/1.4404) ▪ Window: glass ▪ Cover seal: NBR ▪ Seal of the window: NBR ▪ Thread-coating: Graphite-based lubricant varnish
2.2	Cover of the terminal compartment	<ul style="list-style-type: none"> ▪ Cover: CF3M (similar to 316L/1.4404) ▪ Cover seal: NBR ▪ Thread-coating: Graphite-based lubricant varnish
3	Cover lock	<ul style="list-style-type: none"> ▪ Screw: A4 ▪ Clamp: 316L (1.4404)
4	Lock at the housing neck	<ul style="list-style-type: none"> ▪ Screw: A4-70 ▪ Clamp: 316L (1.4404)
5.1	Dummy plug, cable gland, adapter or plug (depending on the device version)	<ul style="list-style-type: none"> ▪ Dummy plug, depending on the device version: <ul style="list-style-type: none"> - PE - PBT-GF ▪ Cable gland: 316L (1.4404) or nickel-plated brass ▪ Adapter: 316L (1.4404/1.4435) ▪ Seal: EPDM ▪ M12 plug: Nickel-plated brass ¹⁾ ▪ 7/8" plug: 316 (1.4401) ²⁾
5.2	Dummy plug, cable gland or adapter (depending on the device version)	<ul style="list-style-type: none"> ▪ Dummy plug: 316L (1.4404) ▪ Cable gland: 316L (1.4404) or nickel-plated brass ▪ Adapter: 316L (1.4404/1.4435) ▪ Seal: EPDM
6	Dummy plug or M12 socket (depending on the device version)	<ul style="list-style-type: none"> ▪ Dummy plug: 316L (1.4404) ▪ M12 socket: 316L (1.4404)
7	Pressure relief stopper	316L (1.4404)
8	Ground terminal	<ul style="list-style-type: none"> ▪ Screw: A4 ▪ Spring washer: A4 ▪ Clamp: 316L (1.4404) ▪ Holder: 316L (1.4404)
9	Nameplate	<ul style="list-style-type: none"> ▪ Plate: 316L (1.4404) ▪ Groove pin: A4 (1.4571)

1) For the version with M12 plug the sealing material is Viton.

2) For the version with 7/8" plug, the sealing material is NBR.

Materials: GT19 housing (plastic)

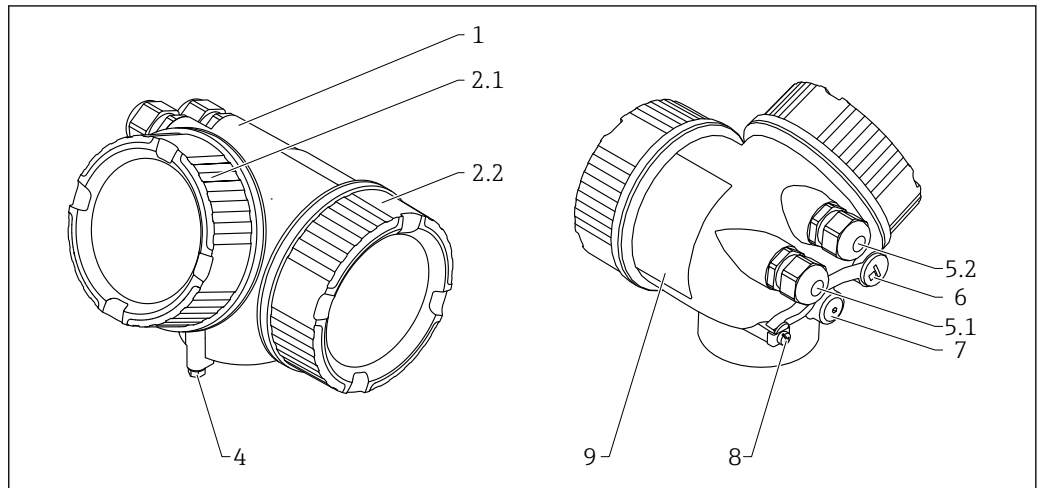

A0013788

No.	Part	Material
1	Housing	PBT
2.1	Cover of the electronics compartment	<ul style="list-style-type: none"> ▪ Cover glass: PC ▪ Cover frame: PBT-PC ▪ Cover seal: EPDM ▪ Thread-coating: Graphite-based lubricant varnish
2.2	Cover of the terminal compartment	<ul style="list-style-type: none"> ▪ Cover: PBT ▪ Cover seal: EPDM ▪ Thread-coating: Graphite-based lubricant varnish
4	Lock at the housing neck	<ul style="list-style-type: none"> ▪ Screw: A4-70 ▪ Clamp: 316L (1.4404)
5.1	Dummy plug, cable gland, adapter or plug (depending on the device version)	<ul style="list-style-type: none"> ▪ Dummy plug, depending on the device version: <ul style="list-style-type: none"> - PE - PBT-GF ▪ Cable gland, depending on the device version: <ul style="list-style-type: none"> - Nickel-plated brass (CuZn) - PA ▪ Adapter: 316L (1.4404/1.4435) ▪ Seal: EPDM ▪ M12 plug: Nickel-plated brass ¹⁾ ▪ 7/8" plug: 316 (1.4401) ²⁾
5.2	Dummy plug, cable gland or adapter (depending on the device version)	<ul style="list-style-type: none"> ▪ Dummy plug, depending on the device version: <ul style="list-style-type: none"> - PE - PBT-GF - Nickel-plated steel ▪ Cable gland, depending on the device version: <ul style="list-style-type: none"> - Nickel-plated brass (CuZn) - PA ▪ Adapter: 316L (1.4404/1.4435) ▪ Seal: EPDM
6	Dummy plug or M12 socket (depending on the device version)	<ul style="list-style-type: none"> ▪ Dummy plug: Nickel-plated brass (CuZn) ▪ M12 socket: Nickel-plated GD-Zn
7	Pressure relief stopper	Nickel-plated brass (CuZn)
8	Ground terminal	<ul style="list-style-type: none"> ▪ Screw: A2 ▪ Spring washer: A4 ▪ Clamp: 304 (1.4301) ▪ Holder: 304 (1.4301)
9	Adhesive nameplate	Plastic

1) For the version with M12 plug the sealing material is Viton.
 2) For the version with 7/8" plug, the sealing material is NBR.

**Materials: GT20 housing
(die-cast aluminum, powder-coated)**

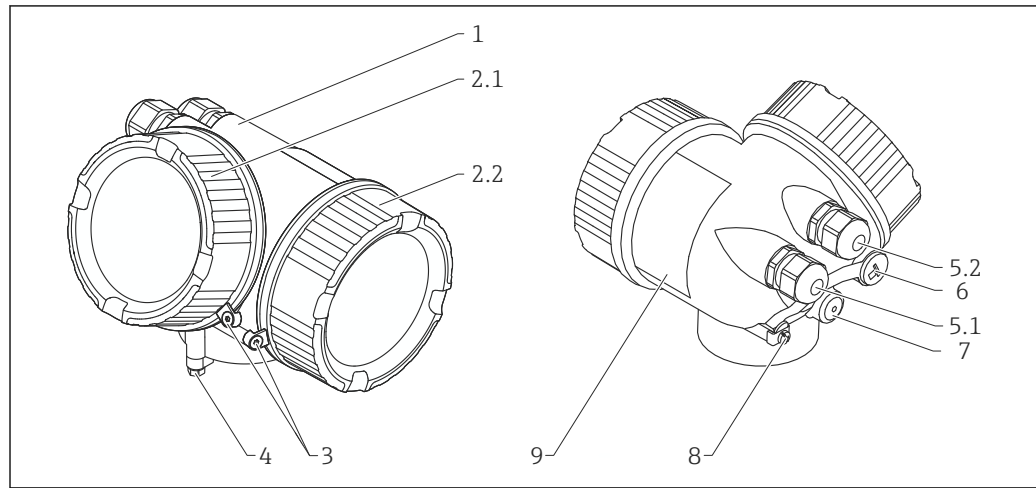

A0036037

Nr.	Part	Material
1	Housing, RAL 5012 (blue)	<ul style="list-style-type: none"> ■ Housing: AlSi10Mg(<0,1% Cu) ■ Coating: Polyester
2.1	Cover of the electronics compartment; RAL 7035 (gray)	<ul style="list-style-type: none"> ■ Cover: AlSi10Mg(<0,1% Cu) ■ Window: Glass ■ Cover seal: NBR ■ Seal of the window: NBR ■ Thread-coating: Graphite-based lubricant varnish
2.2	Cover of the terminal compartment; RAL 7035 (gray)	<ul style="list-style-type: none"> ■ Cover: AlSi10Mg(<0,1% Cu) ■ Cover seal: NBR ■ Thread-coating: Graphite-based lubricant varnish
3	Cover lock	<ul style="list-style-type: none"> ■ Screw: A4 ■ Clamp: 316L (1.4404)
4	Lock at the housing neck	<ul style="list-style-type: none"> ■ Screw: A4-70 ■ Clamp: 316L (1.4404)
5.1	Dummy plug, cable gland, adapter or plug (depending on the device version)	<ul style="list-style-type: none"> ■ Dummy plug, depending on the device version: <ul style="list-style-type: none"> - PE - PBT-GF ■ Cable gland, depending on the device version: <ul style="list-style-type: none"> - Nickel-plated brass (CuZn) - PA ■ Adapter: 316L (1.4404/1.4435) ■ Seal: EPDM ■ M12 plug: Nickel-plated brass ¹⁾ ■ 7/8" plug: 316 (1.4401) ²⁾
5.2	Dummy plug, cable gland or adapter (depending on the device version)	<ul style="list-style-type: none"> ■ Dummy plug, depending on the device version: <ul style="list-style-type: none"> - PE - PBT-GF - Nickel-plated steel ■ Cable gland, depending on the device version: <ul style="list-style-type: none"> - Nickel-plated brass (CuZn) - PA ■ Adapter: 316L (1.4404/1.4435) ■ Seal: EPDM
6	Dummy plug or M12 socket (depending on the device version)	<ul style="list-style-type: none"> ■ Dummy plug : Nickel-plated brass (CuZn) ■ M12 socket: Nickel-plated GD-Zn
7	Pressure relief stopper	Nickel-plated brass (CuZn)

Nr.	Part	Material
8	Ground terminal	<ul style="list-style-type: none"> ■ Screw: A2 ■ Spring washer: A2 ■ Clamp: 304 (1.4301) ■ Holder: 304 (1.4301)
9	Adhesive nameplate	Plastic

- 1) For the version with M12 plug the sealing material is Viton.
- 2) For the version with 7/8" plug, the sealing material is NBR.

Materials: Antenna and process connection

FMR53

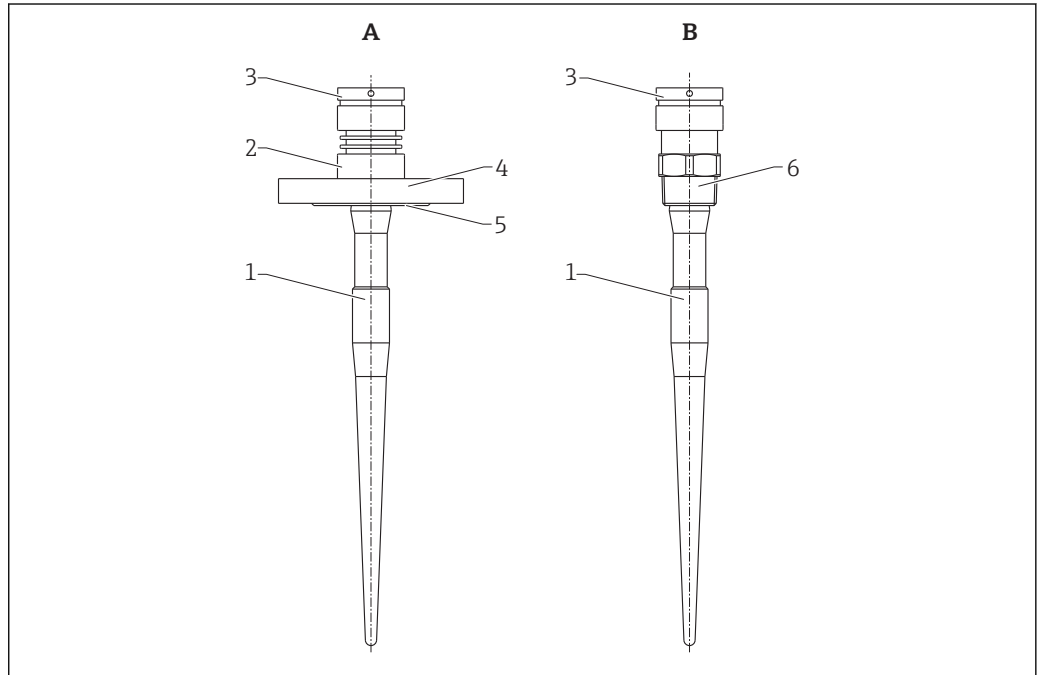

A0018954

- A Flange version
 B Version with threaded connection

Pos.	Part	Material
1	Rod antenna	PTFE
2	Connection	316L (1.4404)
3	Housing adapter	316L (1.4404)
4	Flange	316L (1.4404/1.4435)
5	Cladding	PTFE
6	Connection	316L (1.4404)
		PVDF

FMR54 with horn antenna

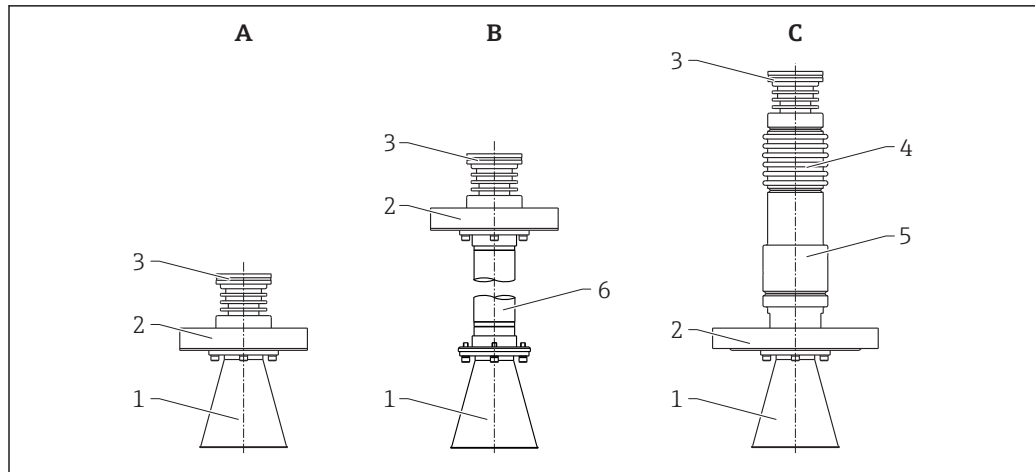

A0018956

- A Compact version
 B Version with antenna extension
 C High temperature version

Pos.	Part	Material		
1	Horn antenna	316L (1.4404)		
	Screw	A4		
	Spring-lock wahser (compact)	A4		
	Nordlock washer (XT and HT version)	A4		
	Process separation cone	Compact version: PTFE	High temperature version: Al ₂ O ₃	
	Seal	Compact version: <ul style="list-style-type: none"> ■ Viton: FKM ■ Kalrez: FFKM (K6375) ■ EPDM 	High temperature version: Graphite	
2	Flange	316L (1.4404/1.4435)		
3	Sensor adapter	316L (1.4404)		
4	Temperature reduction	316L (1.4404)		
5	Process separation	316L (1.4404)		
6	Antenna extension	316L (1.4435)		
	Screw	A4		
	Spring-lock washer	A4		

FMR54 with planar or drip-off antenna

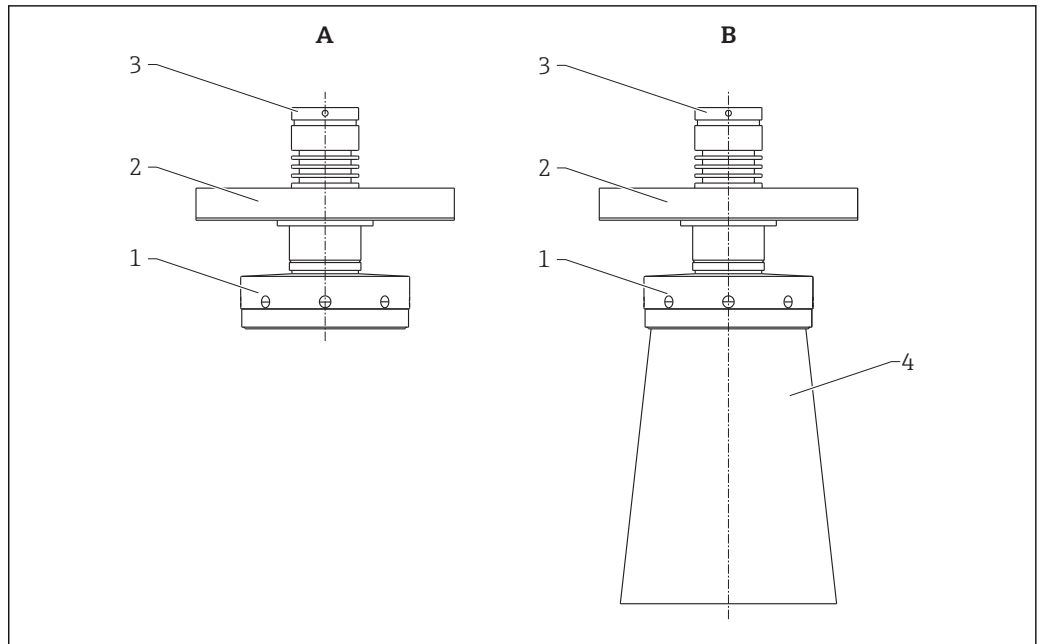

A0018957

- A Version with horn
 B Version without horn

Pos.	Part	Material
1	Sensor adapter	316L (1.4404)
	Antenna retaining ring	316L (1.4404)
	Screw	A2
	Planar antenna	PTFE
	Sealing ring	FKM
2	Flange	316L (1.4404/1.4435)
3	Housing adapter	316L (1.4404)
4	Horn antenna	316L (1.4404)

Materials: Weather protection cover

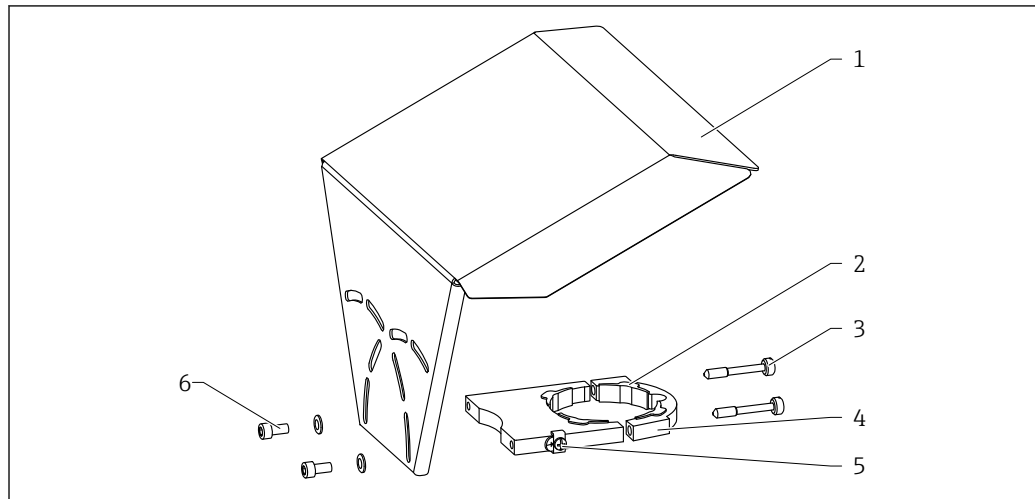

A0015473

No	Part: Material
1	Protection cover: 316L (1.4404)
2	Molded rubber part (4x): EPDM
3	Clamping screw: 316L (1.4404) + carbon fibre
4	Bracket: 316L (1.4404)
5	Ground terminal <ul style="list-style-type: none"> ▪ Screw: A4 ▪ Spring washer: A4 ▪ Clamp: 316L (1.4404) ▪ Holder: 316L (1.4404)
6	<ul style="list-style-type: none"> ▪ Washer: A4 ▪ Cheese head screw: A4-70

Operability

Operating concept

Operator-oriented menu structure for user-specific tasks

- Commissioning
- Operation
- Diagnostics
- Expert level

Operating languages

- English
- Deutsch
- Français
- Español
- Italiano
- Nederlands
- Portuguesa
- Polski
- русский язык (Russian)
- Svenska
- Türkçe
- 中文 (Chinese)
- 日本語 (Japanese)
- 한국어 (Korean)
- Bahasa Indonesia
- tiếng Việt (Vietnamese)
- čeština (Czech)



Feature 500 of the product structure determines which of these languages is preset on delivery.

Quick and save commissioning

- Interactive wizard with graphical interface for easy commissioning via FieldCare/DeviceCare
- Menu guidance with brief explanations of the individual parameter functions
- Standardized operation at the device and in the operating tools

Integrated data storage device (HistoROM)

- Enables transfer of configuration when changing electronic modules
- Records up to 100 event messages in the device
- Records up to 1000 measured values in the device
- Saves the signal curve on commissioning which can later be used as a reference.

Efficient diagnostics increase measurement reliability

- Remedy information is integrated in plain text
- Diverse simulation options and line recorder functions

Integrated Bluetooth module (option for HART devices)

- Easy and fast setup via SmartBlue (app)
- No additional tools or adapters required
- Signal curve via SmartBlue (app)
- Encrypted single point-to-point data transmission (Fraunhofer-Institut, third party, tested) and password-protected communication via Bluetooth® wireless technology

Local operation

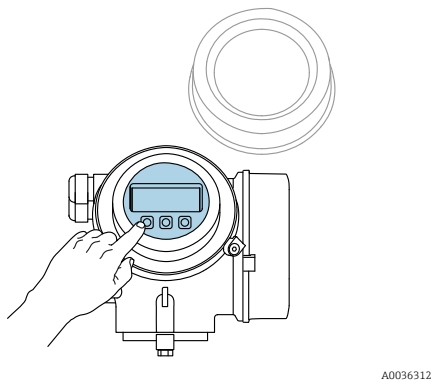
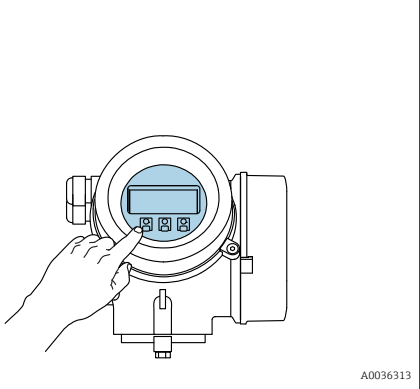
Operation with	Pushbuttons	Touch Control
Order code for "Display; Operation"	Option C "SD02"	Option E "SD03"
		
Display elements	4-line display	4-line display white background lighting; switches to red in event of device error
	Format for displaying measured variables and status variables can be individually configured	
	Permitted ambient temperature for the display: -20 to +70 °C (-4 to +158 °F) The readability of the display may be impaired at temperatures outside the temperature range.	
Operating elements	local operation with 3 push buttons (⊕, ⊖, ⏏)	external operation via touch control; 3 optical keys: ⊕, ⊖, ⏏
	Operating elements also accessible in various hazardous areas	
Additional functionality	Data backup function The device configuration can be saved in the display module.	
	Data comparison function The device configuration saved in the display module can be compared to the current device configuration.	
	Data transfer function The transmitter configuration can be transmitted to another device using the display module.	

Operation with remote display and operating module FHX50

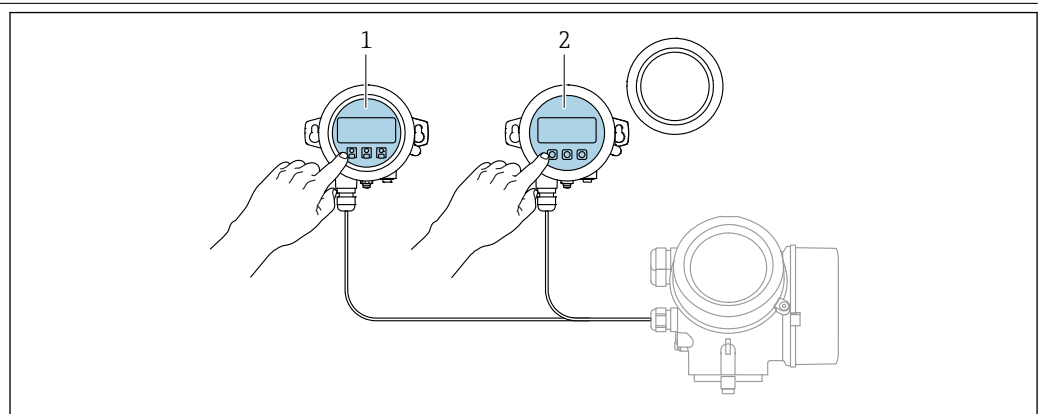

30 FHX50 operating options

- 1 Display and operating module SD03, optical keys; can be operated through the glass of the cover
- 2 Display and operating module SD02, push buttons; cover must be removed

Operation via Bluetooth® wireless technology

Requirements

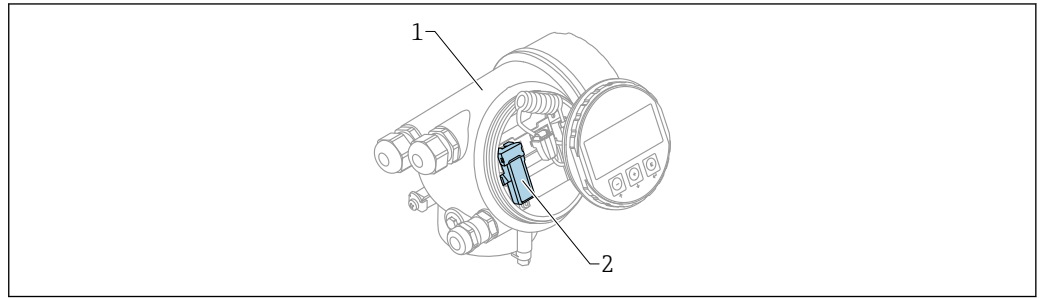

A0036790

☑ 31 Device with Bluetooth module

- 1 Electronics housing of the device
- 2 Bluetooth module

This operation option is only available for devices with Bluetooth module. There are the following options:

- The device has been ordered with a Bluetooth module:
Feature 610 "Accessory Mounted", option NF "Bluetooth"
- The Bluetooth module has been ordered as an accessory (ordering number: 71377355) and has been mounted. See Special Documentation SD02252F.

Operation via SmartBlue (app)

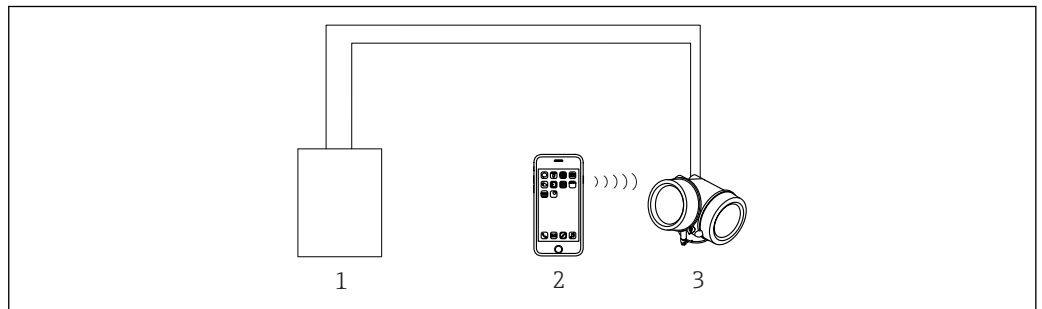

A0034939

☑ 32 Operation via SmartBlue (app)

- 1 Transmitter power supply unit
- 2 Smartphone / tablet with SmartBlue (app)
- 3 Transmitter with Bluetooth module

Remote operation

Via HART protocol

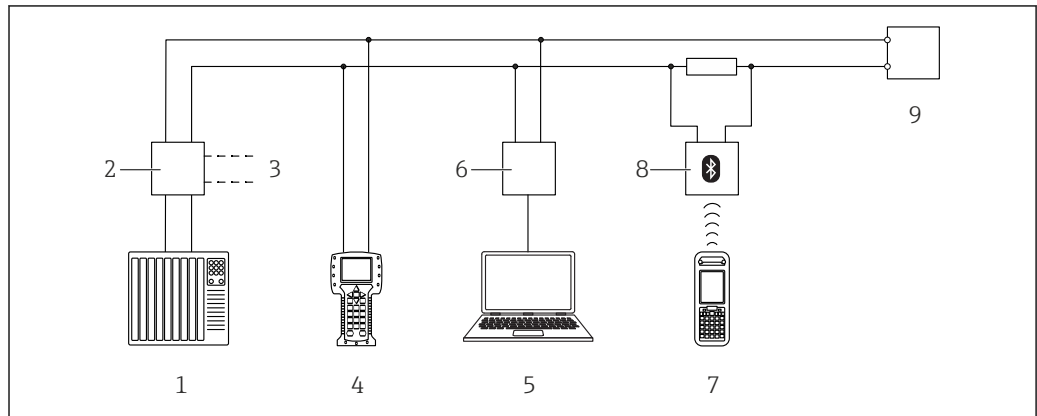

A0036169

33 Options for remote operation via HART protocol

- 1 PLC (Programmable Logic Controller)
- 2 Transmitter power supply unit, e.g. RN221N (with communication resistor)
- 3 Connection for Commubox FXA191, FXA195 and Field Communicator 375, 475
- 4 Field Communicator 475
- 5 Computer with operating tool (e.g. DeviceCare/FieldCare, AMS Device Manager, SIMATIC PDM)
- 6 Commubox FXA191 (RS232) or FXA195 (USB)
- 7 Field Xpert SFX350/SFX370
- 8 VIATOR Bluetooth modem with connecting cable
- 9 Transmitter

Via PROFIBUS PA protocol

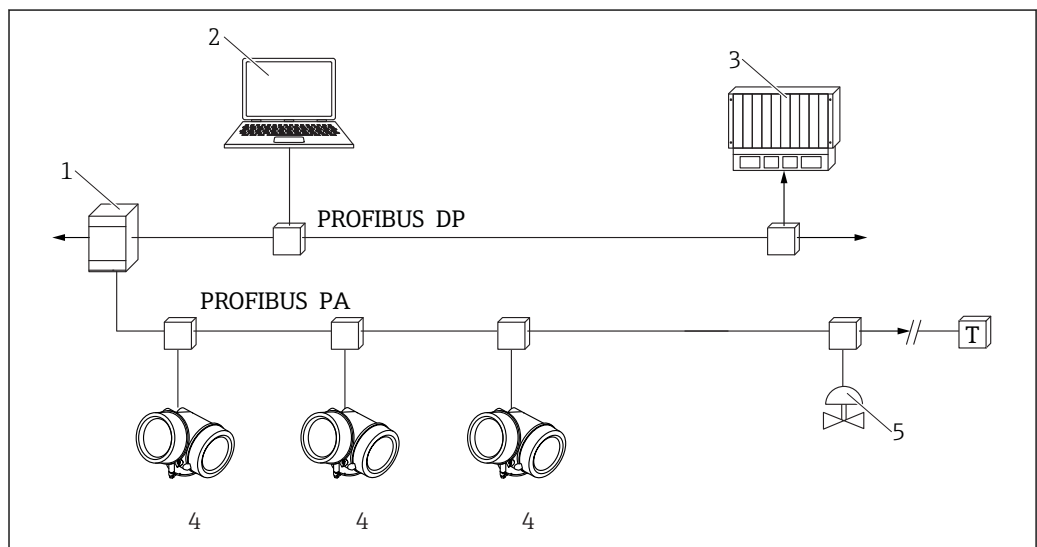

A0036301

34 Options for remote operation via PROFIBUS PA protocol

- 1 Segment coupler
- 2 Computer with Profiboard/Proficard and operating tool (e.g. DeviceCare/FieldCare)
- 3 PLC (Programmable Logic Controller)
- 4 Transmitter
- 5 Additional functions (valves etc.)

Via FOUNDATION Fieldbus

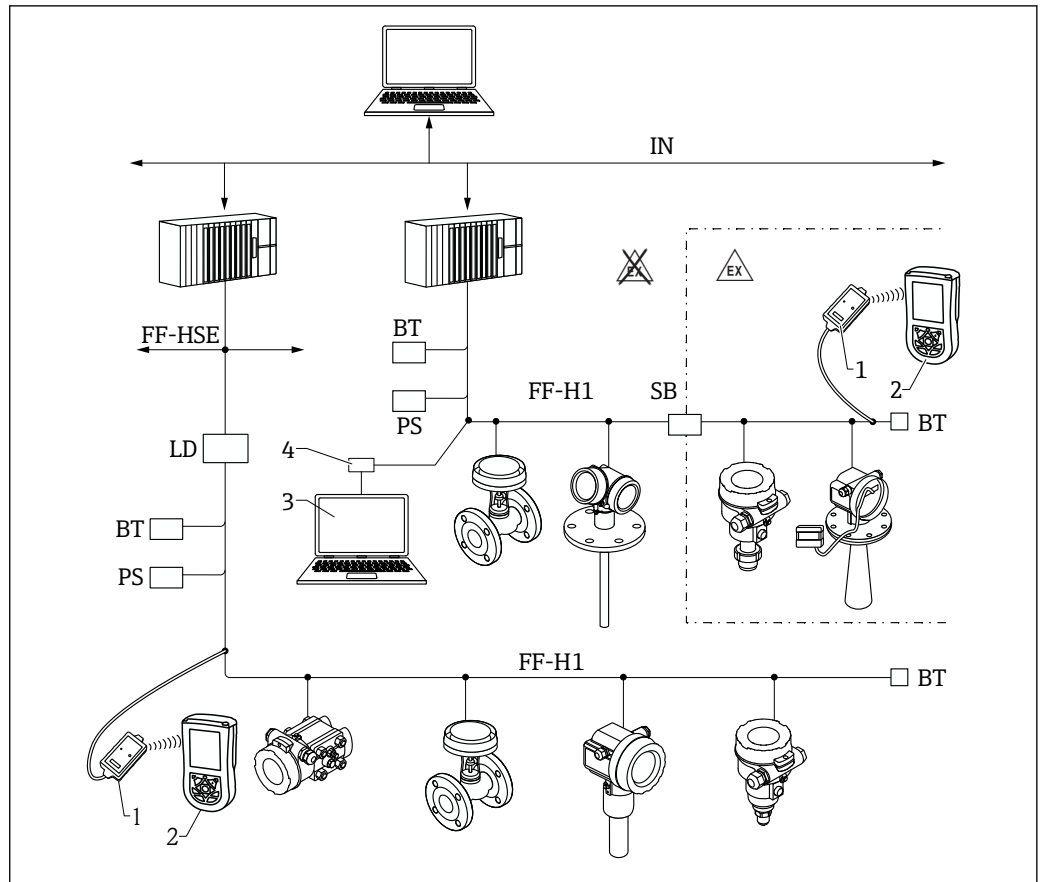

A0017188

35 FOUNDATION Fieldbus system architecture with associated components

- 1 FFblue Bluetooth modem
- 2 Field Xpert SFX350/SFX370
- 3 DeviceCare/FieldCare
- 4 NI-FF interface card

IN	Industrial network
FF-HSE	High Speed Ethernet
FF-H1	FOUNDATION Fieldbus-H1
LD	Linking Device FF-HSE/FF-H1
PS	Bus Power Supply
SB	Safety Barrier
BT	Bus Terminator

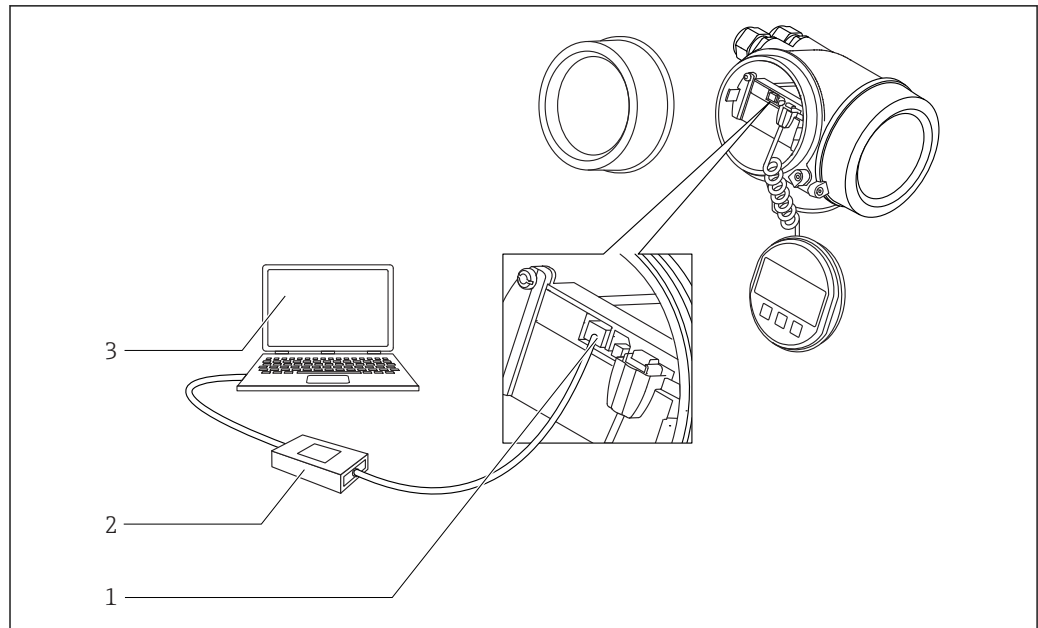
DeviceCare/FieldCare via service interface (CDI)

A0032466

36 DeviceCare/FieldCare via service interface (CDI)

- 1 Service interface (CDI) of the instrument (= Endress+Hauser Common Data Interface)
- 2 Commubox FXA291
- 3 Computer with DeviceCare/FieldCare operating tool

Integration in tank gauging system

The Endress+Hauser Tank Side Monitor NRF81 provides integrated communications for sites with multiple tanks, each with one or more sensors on the tank, such as radar, spot or average temperature, capacitive probe for water detection and/or pressure sensors. Multiple protocols out of the Tank Side Monitor guarantee connectivity to nearly any of the existing industry standard tank gauging protocols. Optional connectivity of analog 4...20 mA sensors, digital I/O and analog output simplify full tank sensor integration. Use of the proven concept of the intrinsically safe HART bus for all on-tank sensors yields extremely low wiring costs, while at the same time providing maximum safety, reliability and data availability.

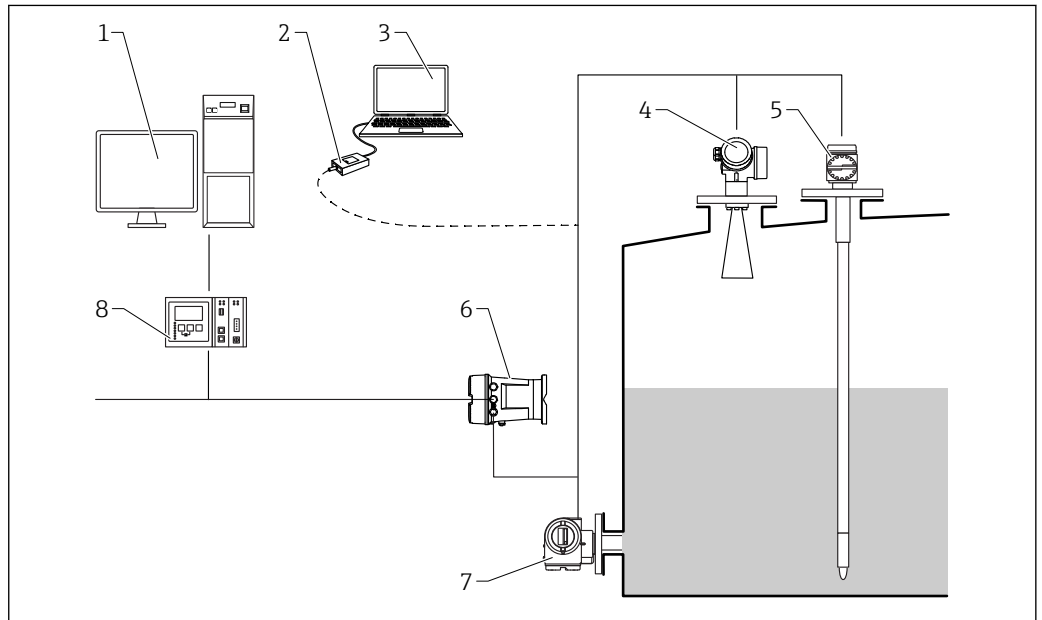

A0017982

37 The complete measuring system consists of:

- 1 Tankvision workstation
- 2 Commubox FXA195 (USB) - optional
- 3 Computer with operating tool (ControlCare) - optional
- 4 Level measuring device
- 5 Temperature measuring device
- 6 Tank Side Monitor NRF81
- 7 Pressure measuring device
- 8 Tankvision Tank Scanner NXA820

SupplyCare inventory management software

SupplyCare is a web-based operating program for coordinating the flow of material and information along the supply chain. SupplyCare provides a comprehensive overview of the levels of geographically distributed tanks and silos, for instance, providing complete transparency over the current inventory situation, regardless of time and location.

Based on the measuring and transmission technology installed onsite, the current inventory data are collected and sent to SupplyCare. Critical levels are clearly indicated and calculated forecasts provide additional security for material requirements planning.

The main functions of SupplyCare:

Inventory visualization

SupplyCare determines the inventory levels in tanks and silos at regular intervals. It displays current and historical inventory data and calculated forecasts of future demand. The overview page can be configured to suit the user's preferences.

Master data management

With SupplyCare you can create and manage the master data for locations, companies, tanks, products and users, as well as user authorization.

Report Configurator

The Report Configurator can be used to create personalized reports quickly and easily. The reports can be saved in a variety of formats, such as Excel, PDF, CSV and XML. The reports can be transmitted in many ways, such as by http, ftp or e-mail.

Event management

Events, such as when levels drop below the safety stock level or plan points, are indicated by the software. In addition, SupplyCare can also notify pre-defined users by e-mail.

Alarms

If technical problems occur, e.g. connection issues, alarms are triggered and alarm e-mails are sent to the System Administrator and the Local System Administrator.

Delivery planning

The integrated delivery planning function automatically generates an order proposal if a pre-set minimum inventory level is undershot. Scheduled deliveries and disposals are monitored continuously by SupplyCare. SupplyCare notifies the user if scheduled deliveries and disposals are not going to be met as planned.

Analysis

In the Analysis module, the most important indicators for the inflow and outflow of the individual tanks are calculated and displayed as data and charts. Key indicators of material management are automatically calculated and form the basis for optimizing the delivery and storage process.

Geographical visualization

All the tanks and the tank inventories are represented graphically on a map (based on Google Maps). The tanks and inventory situations can be filtered by tank group, product, supplier or location.

Multi-language support

The multi-language user interface supports 9 languages, thereby enabling global collaboration on a single platform. The language and settings are recognized automatically using the browser settings.

SupplyCare Enterprise

SupplyCare Enterprise runs by default as a service under Microsoft Windows on an application server in an Apache Tomcat environment. The operators and administrators operate the application via a Web browser from their workstations.

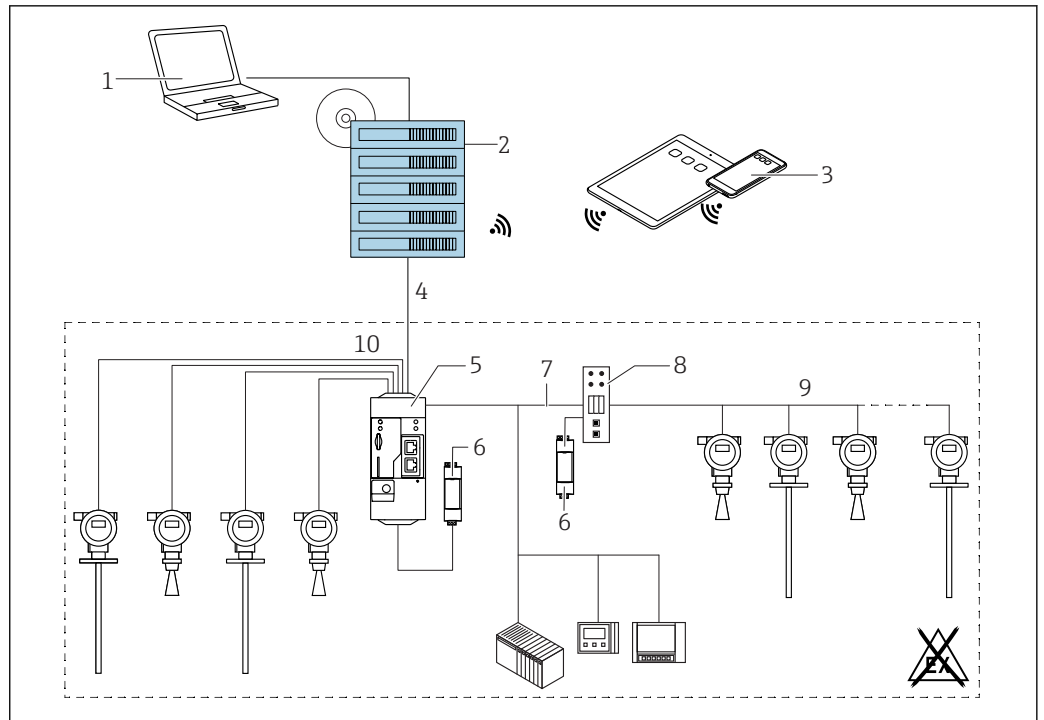

A0034288

38 Example of inventory management platform with SupplyCare Enterprise SCE30B

- 1 SupplyCare Enterprise (via Web browser)
- 2 SupplyCare Enterprise installation
- 3 SupplyCare Enterprise on mobile devices (via Web browser)
- 4 Ethernet/WLAN/UMTS
- 5 Fieldgate FXA42
- 6 Power supply 24 V DC
- 7 Modbus TCP via Ethernet as server/client
- 8 Converter from Modbus to HART Multidrop
- 9 HART Multidrop
- 10 4 x 4 to 20 mA analog input (2-wire/4-wire)

Cloud-based application: SupplyCare Hosting

SupplyCare Hosting is offered as a hosting service (software as a service). Here, the software is installed within the Endress+Hauser IT infrastructure and made available to the user in the Endress+Hauser portal.

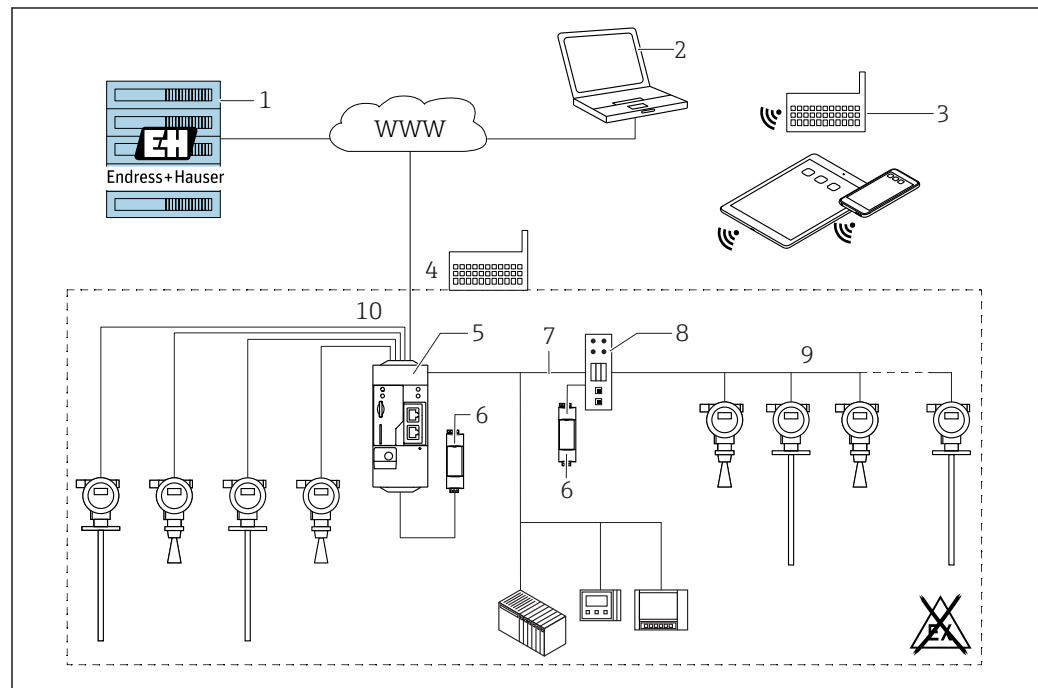

A0034289

39 Example of inventory management platform with SupplyCare Hosting SCH30

- 1 SupplyCare Hosting installation in Endress+Hauser data center
- 2 PC workstation with Internet connection
- 3 Warehouse locations with Internet connection via 2G/3G with FXA42 or FXA30
- 4 Warehouse locations with Internet connection with FXA42
- 5 Fieldgate FXA42
- 6 Power supply 24 V DC
- 7 Modbus TCP via Ethernet as server/client
- 8 Converter from Modbus to HART Multidrop
- 9 HART Multidrop
- 10 4 x 4 to 20 mA analog input (2-wire/4-wire)

With SupplyCare Hosting, users do not need to make the initial software purchase or install and run the IT infrastructure needed. Endress+Hauser constantly update SupplyCare Hosting and enhance the capability of the software in conjunction with the customer. The hosted version of SupplyCare is thus always up-to-date and can be customized to meet different customer requirements. Other services are also offered in addition to the IT infrastructure and the software that is installed in a secure, redundant Endress+Hauser data center. These services include defined availability of the global Endress+Hauser Service and Support Organization and defined response times in a service event.

Certificates and approvals



Currently available certificates and approvals can be called up via the product configurator.

CE mark

The measuring system meets the legal requirements of the applicable EC guidelines. These are listed in the corresponding EC Declaration of Conformity together with the standards applied.

Endress+Hauser confirms successful testing of the device by affixing to it the CE mark.

RoHS

The measuring system complies with the substance restrictions of the Restriction on Hazardous Substances Directive 2011/65/EU (RoHS 2).

RCM-Tick marking

The supplied product or measuring system meets the ACMA (Australian Communications and Media Authority) requirements for network integrity, interoperability, performance characteristics as well as health and safety regulations. Here, especially the regulatory arrangements for electromagnetic compatibility are met. The products are labelled with the RCM- Tick marking on the name plate.



A0029561

Ex approval

- ATEX
- IEC Ex
- CSA
- FM
- NEPSI
- KC
- INMETRO
- TIIS (in preparation)

Additional safety instructions must be observed for applications in hazardous areas. They are contained in the separate "Safety Instructions" (XA) document, which is included in the scope of delivery. Reference is made to the XA on the nameplate of the device.



Details on the available certificates as well as the associated XAs can be found in the **Associated documentation** chapter in the **Safety instructions** section: → 108.

Dual seal according to ANSI/ISA 12.27.01

The devices have been designed according to ANSI/ISA 12.27.01 as dual seal devices, allowing the user to waive the use and save the cost of installing external secondary process seals in the conduit as required by the process sealing sections of ANSI/NFPA 70 (NEC) and CSA 22.1 (CEC). These instruments comply with the North-American installation practice and provide a very safe and cost-saving installation for pressurized applications with hazardous fluids.

Further information can be found in the Safety Instructions (XA) of the relevant devices.

Functional safety

Use for level monitoring (MIN, MAX, range) up to SIL 3 (homogeneous or diverse redundancy), independently evaluated by TÜV Rheinland in accordance with IEC 61508, refer to the "Functional Safety Manual" for information.

WHG

WHG approval: Z-65.16-524

Sanitary compatibility

The PTFE antenna of FMR53 conforms to FDA 21 CFR 177.1550 and USP <88> Class VI.

NACE MR 0175 / ISO 15156

- The wetted, metal materials comply with the requirements of NACE MR 0175 / ISO 15156.
- Declaration of Conformity: see the product structure, feature 580, version JB

NACE MR 0103

- The wetted, metal materials comply with the requirements of NACE MR 0103.
- The Declaration of Conformity is based on NACE MR 0175.
The hardness and intergranular corrosion have been tested, and heat treatment (solution annealed) has been performed. The materials used therefore meet the requirements of NACE MR 0103.
- Declaration of Conformity: see the product structure, feature 580, version JE.

Pressure equipment with allowable pressure ≤ 200 bar (2 900 psi)

Pressure instruments with a flange and threaded boss that do not have a pressurized housing do not fall within the scope of the Pressure Equipment Directive, irrespective of the maximum allowable pressure.

Reasons:

According to Article 2, point 5 of EU Directive 2014/68/EU, pressure accessories are defined as "devices with an operational function and having pressure-bearing housings".

If a pressure instrument does not have a pressure-bearing housing (no identifiable pressure chamber of its own), there is no pressure accessory present within the meaning of the Directive.

Marine certificate

Device	Marine certificate ¹⁾				
	GL	ABS	LR	BV	DNV
FMR53	-	-	-	-	-
FMR54	✓	✓	✓	✓	✓

1) see ordering feature 590 "Additional approval"

Radio standard EN302372-1/2

The devices Micropilot FMR50, FMR51, FMR52, FMR53, FMR54, FMR56 and FMR57 are conform with the TLPR (Tanks Level Probing Radar) standard EN302372-1/2 and can always be used in closed tanks or bins. For installation, points a to f in Annex B of EN302372-1 have to be taken into account.

FCC / Industry Canada

This device complies with Part 15 of the FCC rules. Operation is subject to the following two conditions: (1) This device may not cause harmful interference, and (2) this device must accept any interference received, including interference that may cause undesired operation.

Canada CNR-Gen Section 7.1.3

This device complies with Industry Canada licence-exempt RSS standard(s). Operation is subject to the following two conditions: (1) This device may not interference, and (2) this device must accept any interference, including interference that may cause undesired operation of the device.

Le présent appareil est conforme aux CNR d'Industrie Canada applicables aux appareils radio exempts de licence. L'exploitation est autorisée aux deux conditions suivantes : (1) l'appareil ne doit pas produire de brouillage, et (2) l'utilisateur de l'appareil doit accepter tout brouillage radioélectrique subi, même si le brouillage est susceptible d'en compromettre le fonctionnement.

[Any] changes or modifications not expressly approved by the party responsible for compliance could void the user's authority to operate the equipment.

Japanese radio approval

The devices comply with Japanese Radio Law, Article 6, Section 1(1)



CRN approval

Some device versions have a CRN approval. Devices are CRN approved if the following two conditions are met:

- The device has a CSA approval (Product structure: Feature 010 "Approval")
- The device has a CRN approved process connection according to the following table.

Feature 100 of the product structure	Process connection
AFJ	NPS 2" Cl.150 RF, 316/316L
AFK	NPS 2" Cl.150, PTFE >316/316L
AGJ	NPS 3" Cl.150 RF, 316/316L
AGK	NPS 3" Cl.150, PTFE >316/316L

Feature 100 of the product structure	Process connection
AHJ	NPS 4" Cl.150 RF, 316/316L
AHK	NPS 4" Cl.150, PTFE >316/316L
AJJ	NPS 6" Cl.150 RF, 316/316L
AJK	NPS 6" Cl.150, PTFE >316/316L
AKJ	NPS 8" Cl.150 RF, 316/316L
ALJ	NPS 10" Cl.150 RF, 316/316L
AMJ	NPS 12" Cl.150 RF, 316/316L
ASJ	NPS 3" Cl.300 RF, 316/316L
ATJ	NPS 4" Cl.300 RF, 316/316L
AUJ	NPS 6" Cl.300 RF, 316/316L
AVJ	NPS 8" Cl.300 RF, 316/316L
RGF	Thread ANSI MNPT1-1/2, PVDF
RGJ	Thread ANSI MNPT1-1/2, 316L
RVF	Thread EN10226 R1-1/2, PVDF
RVJ	Thread EN10226 R1-1/2, 316L

-  Process connections without CRN approval are not included in this table.
 - Refer to the product structure to see which process connections are available for a specific device type.
 - For some process connections not listed in the product structure a CRN approval is available on request.
 - CRN approved devices are marked with the registration number OF15872.5C on the nameplate.
-  For device versions listed in the table below, the maximum allowed pressure is reduced if they have a CRN approval. For device versions not listed in the table below the pressure range as indicated in the "Process" chapter →  61 is not affected by the CRN approval.

Product	Antenna ¹⁾	Process connection ²⁾	Seal ³⁾	max. pressure
FMR54			D1: Graphite (XT)	100 bar (1 450 psi)
			D2: Graphite (HT)	100 bar (1 450 psi)

- 1) Feature 070 of the product structure
- 2) Feature 100 of the product structure
- 3) Feature 090 of the product structure

Track record

FMR5x is the upgrade model of the corresponding FMR2xx series.

Test, Certificate

Feature 580 "Test, Certificate"	Designation	Available for
JA	3.1 Material certificate, wetted metallic parts, EN10204-3.1 inspection certificate	<ul style="list-style-type: none"> ■ FMR53 ■ FMR54
JB	Conformity to NACE MR0175, wetted metallic parts	FMR54
JD	3.1 Material certificate, pressurized parts, EN10204-3.1 inspection certificate	FMR53
JE	Conformity to NACE MR0103, wetted metallic parts	FMR54
JF	Conformity to AD2000, wetted metallic parts: Material of all wetted/pressurized parts conform to AD2000 (Technical rules W2, W9, W10)	<ul style="list-style-type: none"> ■ FMR53 ■ FMR54
KD	Helium leak test, internal procedure, inspection certificate	FMR54
KE	Pressure test, internal procedure, inspection certificate	<ul style="list-style-type: none"> ■ FMR53 ■ FMR54
KG	3.1 Material certificate+PMI test (XRF), internal procedure, wetted metallic parts, EN10204-3.1 inspection certificate	FMR54
KP	Liquid penetrant test AD2000-HP5-3 (PT), wetted/pressurized metallic parts, inspection certificate	<ul style="list-style-type: none"> ■ FMR53 ■ FMR54
KQ	Liquid penetrant test ISO23277-1 (PT), wetted/pressurized metallic parts, inspection certificate	<ul style="list-style-type: none"> ■ FMR53 ■ FMR54
KR	Liquid penetrant test ASME VIII-1 (PT), wetted/pressurized metallic parts, inspection certificate	<ul style="list-style-type: none"> ■ FMR53 ■ FMR54
KS	Welding documentation, wetted/pressurized seams consisting of <ul style="list-style-type: none"> ■ Drawing ■ WPQR (Welding Procedure Qualification Report) ■ WPS (Welding Process Specification) ■ Manufacturer Declaration 	<ul style="list-style-type: none"> ■ FMR53 ■ FMR54
KV	Conformity to ASME B31.3: The dimensions, materials of construction, pressure / temperature ratings and identification markings of the device comply with the requirements of ASME B31.3	<ul style="list-style-type: none"> ■ FMR53 ■ FMR54



Test reports, declarations and material test certificates can be obtained electronically from the *W@M Device Viewer* :

Enter the serial number from the nameplate (www.endress.com/deviceviewer)

This applies to the options of the following ordering features:

- 550 "Calibration"
- 580 "Test, Certificate"

**Hard-copy product
documentation**

Hard-copy versions of the test reports, declarations and inspection certificates can also be order via order code 570 "Service", option I7 "Hard-copy product documentation". The documents are then supplied with the product.

Other standards and guidelines

- EN 60529
Degrees of protection provided by enclosures (IP code)
- EN 61010-1
Safety Requirements for Electrical Equipment for Measurement, Control and Laboratory Use
- IEC/EN 61326
"Emission in accordance with Class A requirements". Electromagnetic compatibility (EMC requirements).
- NAMUR NE 21
Electromagnetic compatibility (EMC) of industrial process and laboratory control equipment
- NAMUR NE 43
Standardization of the signal level for the breakdown information of digital transmitters with analog output signal.
- NAMUR NE 53
Software of field devices and signal-processing devices with digital electronics
- NAMUR NE 107
Status classification as per NE107
- NAMUR NE 131
Requirements for field devices for standard applications.
- IEC61508
Functional safety of safety-related electric/electronic/programmable electronic systems

Ordering information

Ordering information

Detailed ordering information is available from the following sources:

- In the Product Configurator on the Endress+Hauser website: www.endress.com -> Click "Corporate" -> Select your country -> Click "Products" -> Select the product using the filters and search field -> Open product page -> The "Configure" button to the right of the product image opens the Product Configurator.
- From your Endress+Hauser Sales Center: www.addresses.endress.com



Product Configurator - the tool for individual product configuration

- Up-to-the-minute configuration data
- Depending on the device: Direct input of measuring point-specific information such as measuring range or operating language
- Automatic verification of exclusion criteria
- Automatic creation of the order code and its breakdown in PDF or Excel output format
- Ability to order directly in the Endress+Hauser Online Shop

3-point linearity protocol

i The following notes must be taken into account if option F3 ("3 point linearity protocol") has been selected in feature 550 ("Calibration").

The 3 points of the linearity protocol are defined as follows:

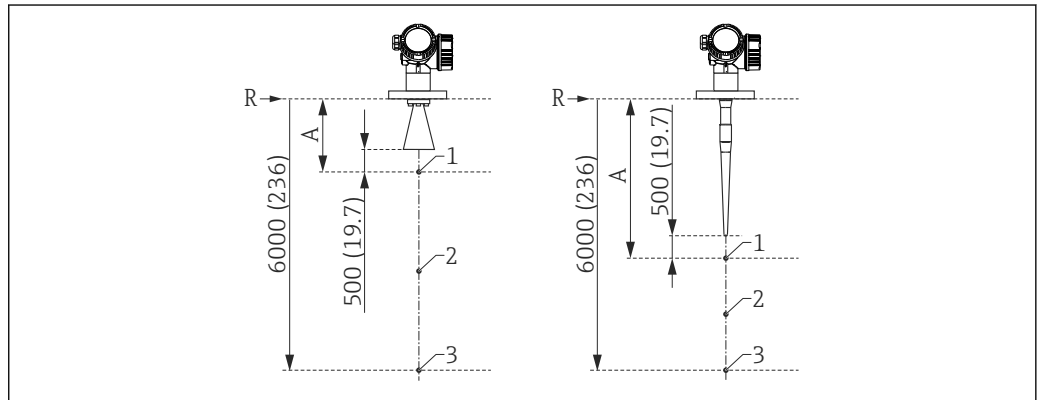

40 Points of the 3-point linearity protocol; Dimensions: mm (in)

- A Distance from reference point R to first measuring point
- R Reference point of the measurement
- 1 First measuring point
- 2 Second measuring point (centrally between first and third measuring point)
- 3 Third measuring point

Measuring point	Position
1 st measuring point	<ul style="list-style-type: none"> ▪ At the distance A from the reference point ▪ A = antenne length + antenna extension (if present) + 500 mm (19.7 in) ▪ Minimum distance: $A_{\min} = 1\,000\text{ mm (39.4 in)}$
2 nd measuring point	centrally between 1 st and 3 rd measuring point
3 rd measuring point	6 000 mm (236 in) below the reference point, R

i The position of the measuring points may vary by $\pm 1\text{ cm } (\pm 0.04\text{ in})$.

i The linearity is checked under reference conditions.

5-point linearity protocol

i The following notes must be taken into account if option F4 ("5 point linearity protocol") has been selected in feature 550 ("Calibration").

The five points of the linearity protocol are evenly distributed across the measuring range (0% to 100%). In order to define the measuring range, **Empty calibration** (E) and **Full calibration** (F) have to be specified ⁷⁾.

The following restrictions have to be taken into account when defining E and F:

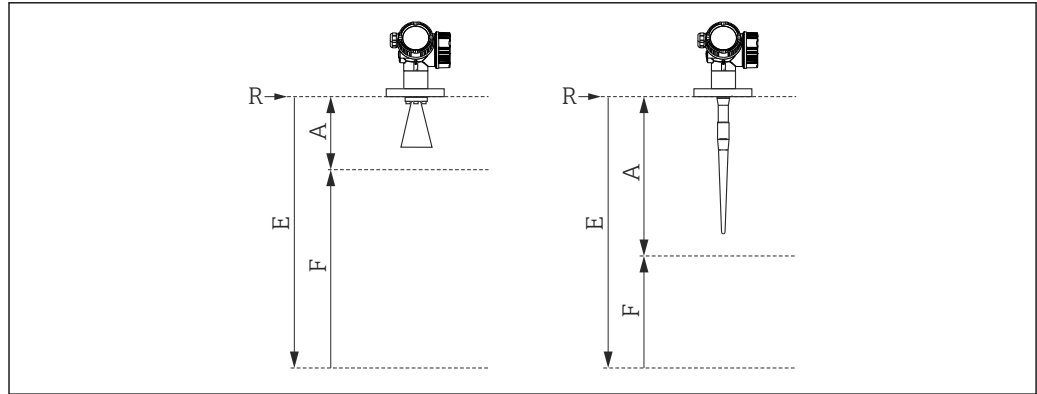

A0019161

Device version	Minimum distance between reference point (R) and 100% level	Minimum span	Maximum value for "Empty calibration"
FMR53/FMR54 Without antenna extension	$A \geq \text{antenna length} + 200 \text{ mm (8 in)}^1$	$F \geq 400 \text{ mm (16 in)}$	$E \leq 20 \text{ m (66 ft)}$
FMR54 with antenna extension ²⁾	$A \geq \text{antenna length} + \text{antenna extension} + 200 \text{ mm (8 in)}^3$		

- 1) Minimum value for FMR53: 590 mm (23.6 in); Minimum value for FMR54: 400 mm (16 in)
- 2) Feature 610 "Accessory Mounted", option OM, ON, OR or OS
- 3) Minimum value: 400 mm (8 in)

i The linearity is checked under reference conditions.

i The selected values of **Empty calibration** and **Full calibration** are only used to record the linearity protocol and are reset to their probe specific default values thereafter. If values different from the default are required, they must be ordered as a customized parametrization → 97.

7) If E and F are not specified, probe dependent default values will be used instead.

Customized parametrization If the option IJ "Customized parametrization HART", IK "Customized parametrization PA" or IL "Customized parametrization FF" has been selected in feature 570 "Service", customer specific presettings can be selected for the following parameters:



Parameter	Communication	Selection list / range of values
Setup → Distance unit	<ul style="list-style-type: none"> ■ HART ■ PA ■ FF 	<ul style="list-style-type: none"> ■ in ■ ft ■ mm ■ m
Setup → Empty calibration	<ul style="list-style-type: none"> ■ HART ■ PA ■ FF 	max. 70 m (230 ft)
Setup → Full calibration	<ul style="list-style-type: none"> ■ HART ■ PA ■ FF 	max. < 70 m (230 ft)
Setup → Adv. Setup → Current output 1/2 → Damping	HART	0 to 999.9 s
Setup → Adv. Setup → Current output 1/2 → Failure mode	HART	<ul style="list-style-type: none"> ■ Min ■ Max ■ Last valid value
Setup → Adv. Setup → Current output 1/2 → Burst mode	HART	<ul style="list-style-type: none"> ■ Off ■ On

Tagging (TAG)

Ordering feature	895: Marking
Option	Z1: Tagging (TAG), see additional spec.
Position of the measuring point marking	To be selected in the additional specifications: <ul style="list-style-type: none"> ■ Tag plate Stainless Steel ■ Self-adhesive paper label ■ Supplied label/plate ■ RFID TAG ■ RFID TAG + Tag plate Stainless Steel ■ RFID TAG + Self-adhesive paper label ■ RFID TAG + Supplied label/plate
Definition of the measuring point designation	To be defined in the additional specifications: 3 lines containing up to 18 characters each The measuring point designation appears on the selected label and/or the RFID TAG.
Designation in the Electronic Name Plate (ENP)	The first 32 characters of the measuring point designation
Designation on the display module	The first 12 characters of the measuring point designation

Services

The following services can be selected via the product structure in the Product Configurator⁸⁾:

- PWIS free (PWIS: paint wetting impairment substances)
- Customized parametrization HART →  97
- Customized parametrization PA →  97
- Customized parametrization FF →  97
- Without tooling DVD (FieldCare)

8) Feature 570 of the product structure

Application Packages

Heartbeat Diagnostics

Availability

Available in all device versions.

Function

- Continuous self-monitoring of the device.
- Diagnostic messages output to
 - the local display.
 - an asset management system (e.g. FieldCare/DeviceCare).
 - an automation system (e.g. PLC).

Advantages

- Device condition information is available immediately and processed in time.
- The status signals are classified in accordance with VDI/VDE 2650 and NAMUR recommendation NE 107 and contain information about the cause of the error and remedial action.

Detailed description

See Operating Instructions of the device (→  108); chapter "Diagnostics and trouble shooting"

Heartbeat Verification

Availability

Available for the following options of feature 540 "Application Package":

- EH: Heartbeat Verification + Monitoring
- EJ: Heartbeat Verification

Device functionality checked on demand

- Verification of the correct functioning of the measuring device within specifications.
- The verification result provides information about the condition of the device: **Passed** or **Failed**.
- The results are documented in a verification report.
- The automatically generated report supports the obligation to demonstrate compliance with internal and external regulations, laws and standards.
- Verification is possible without interrupting the process.

Advantages

- No onsite presence is required to use the function.
- The DTM⁹⁾ triggers verification in the device and interprets the results. No specific knowledge is required on the part of the user.
- The verification report can be used to prove quality measures to a third party.
- **Heartbeat Verification** can replace other maintenance tasks (e.g. periodic check) or extend the test intervals.

SIL/WHG-locked devices¹⁰⁾

- The **Heartbeat Verification** module contains a wizard for the proof test which must be performed at appropriate intervals for the following applications:
 - SIL (IEC61508/IEC61511)
 - WHG (German Water Resources Act)
- To perform a proof test, the device must be locked (SIL/WHG locking).
- The wizard can be used via FieldCare, DeviceCare or a DTM-based process control system.



In the case of SIL-locked and WHG-locked devices, it is **not** possible to perform verification without additional measures (e.g. by-passing of the output current) because the output current must be simulated (Increased safety mode) or the level must be approached manually (Expert mode) during subsequent re-locking (SIL/WHG locking).

Detailed description



SD01871F

9) DTM: Device Type Manager; controls device operation via DeviceCare, FieldCare or a DTM-based process control system.

10) Only relevant for devices with SIL or WHG approval: order code 590 ("Additional approval"), option LA ("SIL") or LC ("WHG").

Heartbeat Monitoring

Availability

Available for the following options of feature 540 "Application Package":
EH: Heartbeat Verification + Monitoring

Function

- In addition to the verification parameters, the corresponding parameter values are also logged.
- Existing measured variables, such as the echo amplitude, are used in the **Foam detection** and **Build-up detection** wizards.



For Micropilot FMR5x, the **Foam detection** and **Build-up detection** wizards cannot be used together.

"Foam detection" wizard

- The Heartbeat Monitoring module contains the **Foam detection** wizard.
- This wizard is used to configure automatic foam detection, which detects foam on the product surface on the basis of the reduced signal amplitude. Foam detection can be linked to a switch output in order to control a sprinkler system, for example, which dissolves the foam.
- This wizard can be used via FieldCare, DeviceCare or a DTM-based process control system.

"Build-up detection" wizard

- The Heartbeat Monitoring module contains the **Build-up detection** wizard.
- The wizard is used to configure automatic buildup detection, which detects the buildup of deposits on the antenna on the basis of the increased area of the coupling signal. Buildup detection can be linked to a switch output in order to control a compressed air system, for example, to clean the antenna.
- This wizard can be used via FieldCare, DeviceCare or a DTM-based process control system.

Advantages

- Early detection of changes (trends) to ensure plant availability and product quality.
- Use of information for the proactive planning of measures (e.g. cleaning/maintenance).
- Identification of undesirable process conditions as the basis to optimizing the facility and the processes.
- Automated control of measures to remove foam or buildup.



Detailed description



SD01871F

Accessories

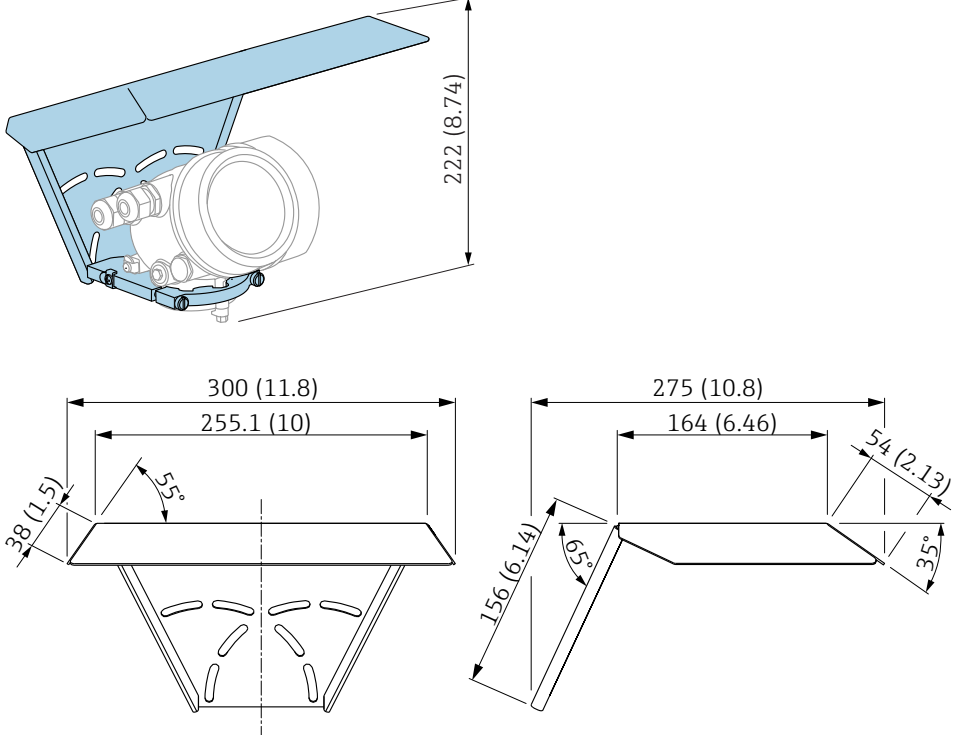
Device-specific accessories Weather protection cover

Accessory	Description
Weather protection cover	 <p data-bbox="1474 734 1528 748">A0015466</p> <p data-bbox="1474 1146 1528 1160">A0015472</p> <p data-bbox="416 1171 925 1200">☑ 41 Weather protection cover; Dimensions: mm (in)</p> <p data-bbox="416 1227 1493 1305">  The weather protection cover can be ordered together with the device (product structure, feature 620 "Accessory Enclosed", option PB "Weather Protection Cover"). Alternatively, it can be separately ordered as an accessory; order code 71162242. </p>

Antenna extension FAR10 (for FMR54)

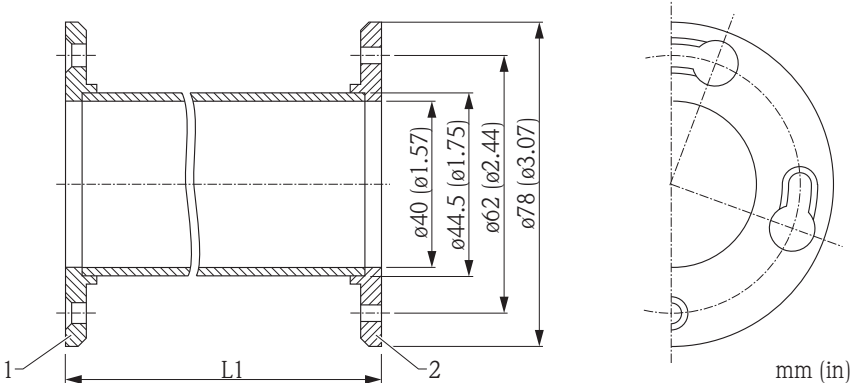
Accessory	Description
Antenna extension FAR10 (for FMR54)	 <p> <i>1 Instrument connection</i> <i>2 Horn connection</i> </p> <p> Material: <ul style="list-style-type: none"> ▪ 316L (1.4404) ▪ Alloy B2 ▪ Alloy C4 </p> <p> Length L1: <ul style="list-style-type: none"> ▪ 100 mm (4 in) ▪ 200 mm (8 in) ▪ 300 mm (12 in) ▪ 400 mm (16 in) </p> <p> Detailed ordering information is available from the following sources: <ul style="list-style-type: none"> ▪ In the Product Configurator on the Endress+Hauser website: www.endress.com → Select country → Instruments → Select device → Product page function: Configure this product ▪ From your Endress+Hauser Sales Center: www.endress.com/worldwide </p>

A0018879

Remote display FHX50

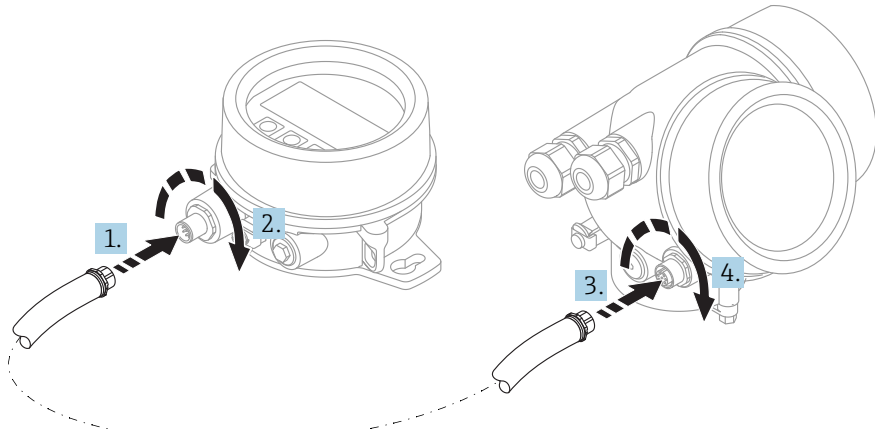
Accessories	Description
Remote display FHX50	<div style="text-align: center;">  </div> <p style="text-align: right; font-size: small;">A0019128</p> <ul style="list-style-type: none"> ■ Material: <ul style="list-style-type: none"> - Plastic PBT - 316L/1.4404 - Aluminum ■ Degree of protection: IP68 / NEMA 6P and IP66 / NEMA 4x ■ Suitable for display modules: <ul style="list-style-type: none"> - SD02 (push buttons) - SD03 (touch control) ■ Connecting cable: <ul style="list-style-type: none"> - Cable supplied with device up to 30 m (98 ft) - Standard cable supplied by customer up to 60 m (196 ft) ■ Ambient temperature range: -40 to 80 °C (-40 to 176 °F) ■ Ambient temperature range (option): -50 to 80 °C (-58 to 176 °F) ¹⁾ <p> i ■ If the remote display should be used, order the device version "Prepared for display FHX50" (feature 030, version L, M or N). For the FHX50, you must select option A: "Prepared for display FHX50" under feature 050 "Measuring device version". </p> <p> i ■ If the device version "Prepared for display FHX50" was not originally ordered and a FHX50 display is to be retrofitted, you must select version B "Not prepared for display FHX50" under feature 050: "Measuring device version" when ordering the FHX50. In this case, a retrofit kit for the device is supplied with the FHX50. The kit can be used to prepare the device so that the FHX50 can be used. </p> <p> i Use of the FHX50 may be restricted for transmitters with an approval. A device can only be retrofitted with the FHX50 if the option L, M or N ("Prepared for FHX50") is listed under <i>Basic specifications</i>, item 4 "Display, operation" in the Safety Instructions (XA) for the device. Also pay attention to the Safety Instructions (XA) of the FHX50. </p> <p> i Retrofitting is not possible on transmitters with: <ul style="list-style-type: none"> ■ An approval for use in areas with flammable dust (dust ignition-proof approval) ■ Ex nA type of protection </p> <p> i For details, see document SD01007F. </p>

1) This range is valid if option JN "Ambient temperature transmitter -50 °C (-58 °F)" has been selected in ordering feature 580 "Test, Certificate". If the temperature is permanently below -40 °C (-40 °F), failure rates may be increased.



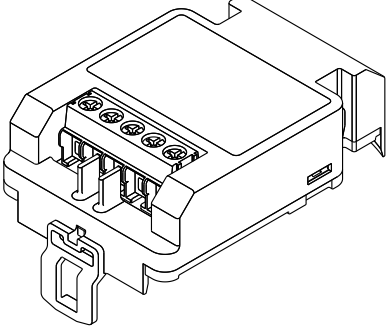



Overvoltage protection

Accessory	Description
Overvoltage protection for 2-wire-devices OVP10 (1 channel) OVP20 (2 channel)	<div style="text-align: right; margin-bottom: 10px;">A0021734</div>  <p>Technical data</p> <ul style="list-style-type: none"> ▪ Resistance per channel: $2 * 0.5 \Omega_{max}$ ▪ Threshold DC voltage: 400 to 700 V ▪ Threshold impulse voltage: < 800 V ▪ Capacitance at 1 MHz: < 1.5 pF ▪ Nominal arrest impulse voltage (8/20 μs): 10 kA ▪ Suited for wire cross-sections: 0.2 to 2.5 mm² (24 to 14 AWG) <p>i Ordering with device The overvoltage protection module is preferably ordered with the device. See product structure, feature 610 "Accessory mounted", option NA "Overvoltage protection". Separate ordering of the module is only necessary if a device is to be retrofitted with the overvoltage protection.</p> <p>i Order code for retrofitting</p> <ul style="list-style-type: none"> ▪ For 1-channel devices (feature 020, option A) OVP10: 71128617 ▪ For 2-channel devices (feature 020, option B, C, E or G) OVP20 : 71128619 <p>Housing lid for retrofitting In order to keep the necessary safety distances, the housing lid needs to be replaced if the device is retrofitted with the overvoltage protection. Depending on the housing type, the order code of the suitable lid is as follows:</p> <ul style="list-style-type: none"> ▪ GT18 housing: Lid 71185516 ▪ GT19 housing: Lid 71185518 ▪ GT20 housing: Lid 71185516 <p>i Restrictions for retrofitting Depending on the approval of the transmitter the usage of the OVP module may be restricted. A device may only be retrofitted with an OVP module if the option NA (overvoltage protection) is quoted under <i>Optional Specifications</i> in the Safety Instructions (XA) pertaining to the device.</p> <p>i For details refer to SD01090F.</p>

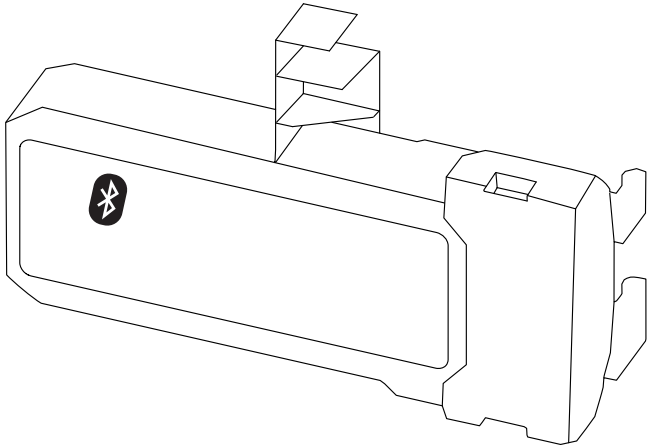
Gas-tight feedthrough

Accessory	Description
Gas-tight feedthrough	Chemically inert glass feedthrough; prevents migration of gases into the electronics housing. To be ordered with the device: product structure, feature 610 "Accessory Mounted", option NC "Gas-tight feedthrough"

Bluetooth module for HART devices

Accessory	Description
Bluetooth module	 <p style="text-align: right; font-size: small;">A0036493</p> <ul style="list-style-type: none"> ▪ Quick and easy commissioning via SmartBlue (app) ▪ No additional tools or adapters required ▪ Signal curve via SmartBlue (app) ▪ Encrypted single point-to-point data transmission (tested by Fraunhofer institute) and password protected communication via Bluetooth® wireless technology ▪ Range under reference conditions: > 10 m (33 ft) <p> When using the Bluetooth module the minimum supply voltage increases by up to 3 V.</p> <p> Ordering with device The Bluetooth module is preferably ordered with the device. See product structure, feature 610 "Accessory Mounted", option NF "Bluetooth". A separate order is only necessary in case of retrofitting.</p> <p> Order code for retrofitting Bluetooth module (BT10): 71377355</p> <p> Restrictions in case of retrofitting Depending on the approval of the transmitter, application of the Bluetooth module may be restricted. A device may only be retrofitted with a Bluetooth module if the option <i>NF</i> (Bluetooth) is listed in the associated Safety Instructions (XA) under <i>Optional specifications</i>.</p> <p> For details refer to SD02252F.</p>

Communication-specific accessories

Accessory	Description
Commubox FXA195 HART	For intrinsically safe HART communication with FieldCare via the USB interface.  For details refer to Technical Information TI00404F

Accessory	Description
Commubox FXA291	Connects Endress+Hauser field devices with CDI interface (= Endress+Hauser Common Data Interface) to the USB interface of a computer. Order code: 51516983  For details refer to Technical Information TI00405C

Accessory	Description
HART Loop Converter HMX50	Evaluates the dynamic HART variables and converts them to analog current signals or limit values. Order code: 71063562  For details refer to Technical Information TI00429F and Operating Instructions BA00371F

Accessory	Description
WirelessHART Adapter SWA70	Connects field devices to a WirelessHART network. The WirelessHART adapter can be mounted directly at a HART device and is easily integrated into an existing HART network. It ensures safe data transmission and can be operated in parallel with other wireless networks.  For details refer to Operating Instructions BA00061S

Accessories	Description
Connect Sensor FXA30/FXA30B	Fully integrated, battery-powered gateway for simple applications with SupplyCare Hosting. Up to 4 field devices with 4 to 20 mA communication (FXA30/FXA30B), serial Modbus (FXA30B) or HART (FXA30B) can be connected. With its robust design and ability to run for years on the battery, it is ideal for remote monitoring in isolated locations. Version with LTE (USA, Canada and Mexico only) or 3G mobile transmission for worldwide communication.  For details, see "Technical Information" TI01356S and Operating Instructions BA01710S.

Accessories	Description
Fieldgate FXA42	Fieldgates enable communication between connected 4 to 20 mA, Modbus RS485 and Modbus TCP devices and SupplyCare Hosting or SupplyCare Enterprise. The signals are transmitted either via Ethernet TCP/IP, WLAN or mobile communications (UMTS). Advanced automation capabilities are available, such as an integrated Web-PLC, OpenVPN and other functions.  For details, see "Technical Information" TI01297S and Operating Instructions BA01778S.



Accessories	Description
SupplyCare Enterprise SCE30B	Inventory management software that visualizes levels, volumes, masses, temperatures, pressures, densities or other tank parameters. The parameters are recorded and transmitted by means of gateways of the type Fieldgate FXA42. This Web-based software is installed on a local server and can also be visualized and operated with mobile terminals such as a smartphone or tablet.  For details, see "Technical Information" TI01228S and Operating Instructions BA00055S

Accessories	Description
SupplyCare Hosting SCH30	Inventory management software that visualizes levels, volumes, masses, temperatures, pressures, densities or other tank parameters. The parameters are recorded and transmitted by means of gateways of the type Fieldgate FXA42, FXA30 and FXA30B. SupplyCare Hosting is offered as a hosting service (Software as a Service, SaaS). In the Endress+Hauser portal, the user is provided with the data over the Internet.  For details, see "Technical Information" TI01229S and Operating Instructions BA00050S.



Accessory	Description
Field Xpert SFX350	Field Xpert SFX350 is a mobile computer for commissioning and maintenance. It enables efficient device configuration and diagnostics for HART and FOUNDATION fieldbus devices in the non-Ex area .  For details, see Operating Instructions BA01202S

Accessory	Description
Field Xpert SFX370	Field Xpert SFX370 is a mobile computer for commissioning and maintenance. It enables efficient device configuration and diagnostics for HART and FOUNDATION fieldbus devices in the non-Ex area and the Ex area .  For details, see Operating Instructions BA01202S

Service-specific accessories

Accessory	Description
DeviceCare SFE100	Configuration tool for HART, PROFIBUS and FOUNDATION Fieldbus devices  Technical Information TI01134S  <ul style="list-style-type: none"> DeviceCare is available for download at www.software-products.endress.com. The download requires a registration in the Endress+Hauser software portal. Alternatively, a DeviceCare DVD can be ordered with the device. Product structure: Feature 570 "Service", Option IV "Tooling DVD (DeviceCare Setup)".
FieldCare SFE500	FDT-based Plant Asset Management tool. Helps to configure and maintain all field devices of your plant. By supplying status information it also supports the diagnosis of the devices.  Technical Information TI00028S

System components

Accessory	Description
Graphic Data Manager Memograph M	The graphic data manager Memograph M provides information on all the relevant process variables. Measured values are recorded correctly, limit values are monitored and measuring points analyzed. The data are stored in the 256 MB internal memory and also on an SD card or USB stick.  For details refer to Technical Information TI00133R and Operating Instructions BA00247R
RN221N	Active barrier with power supply for safe separation of 4 to 20 mA current circuits. Provides bi-directional HART transmission.  For details refer to Technical Information TI00073R and Operating Instructions BA00202R
RNS221	Transmitter supply for 2-wire sensors or transmitters exclusively for non-Ex areas. Provides bi-directional communication using the HART communication sockets.  For details refer to Technical Information TI00081R and Operating Instructions KA00110R

Documentation



The following document types are available:

In the Download Area of the Endress+Hauser Internet site: www.endress.com → Download

Standard documentation

Micropilot FMR53, FMR54

Correlation of documentations to the device:

Device	Power supply, output	Communication	Document type	Document code
FMR53 FMR54	A, B, C, K, L	HART	Operating Instructions	BA01050F/00/EN
			Brief Operating Instructions	KA01101F/00/EN
			Description of Device Parameters	GP01014F/00/EN
	G	PROFIBUS PA	Operating Instructions	BA01126F/00/EN
			Brief Operating Instructions	KA01130F/00/EN
			Description of Device Parameters	GP01018F/00/EN
E	FOUNDATION Fieldbus	Operating Instructions	BA01122F/00/EN	
		Brief Operating Instructions	KA01126F/00/EN	
		Description of Device Parameters	GP01017F/00/EN	

Supplementary documentation

Application Package ¹⁾	Document type	Document code
<ul style="list-style-type: none"> ■ EH: Heartbeat Verification + Monitoring ■ EJ: Heartbeat Verification 	Special documentation	SD01871F

1) Feature 540 of the product structure

Device	Document type	Document code
Fieldgate FXA520	Technical Information	TI00369F
Tank Side Monitor NRF81	Technical Information	TI01251G
	Operating Instructions	BA01465G
	Description of Device Parameters	GP01083G

Safety Instructions (XA)

Depending on the approval, the following Safety Instructions (XA) are supplied with the device. They are an integral part of the Operating Instructions.

Feature 010	Approval	Available for	Feature 020 "Power Supply; Output"				
			A ¹⁾	B ²⁾	C ³⁾	E ⁴⁾ /G ⁵⁾	K ⁶⁾ /L ⁷⁾
BA	ATEX: II 1 G Ex ia IIC T6-T1 Ga	<ul style="list-style-type: none"> ■ FMR53 ■ FMR54 	XA00677F	XA00677F	XA00677F	XA00685F	-
BB	ATEX: II 1/2 G Ex ia IIC T6-T1 Ga/Gb	<ul style="list-style-type: none"> ■ FMR53 ■ FMR54 	XA00677F	XA00677F	XA00677F	XA00685F	-
BC	ATEX: II 1/2 G Ex d [ia] IIC T6-T1 Ga/Gb	<ul style="list-style-type: none"> ■ FMR53 ■ FMR54 	XA00680F	XA00680F	XA00680F	XA00688F	XA00680F
BD	ATEX: II 1/2/3 G Ex ic [ia Ga] IIC T6-T1 Ga/Gb/Gc	<ul style="list-style-type: none"> ■ FMR53 ■ FMR54 	XA00678F	XA00678F	XA00678F	XA00686F	XA00678F
BG	ATEX: II 3 G Ex nA IIC T6-T1 Gc	<ul style="list-style-type: none"> ■ FMR53 ■ FMR54 	XA00679F	XA00679F	XA00679F	XA00687F	XA00679F

Feature 010	Approval	Available for	Feature 020 "Power Supply; Output"				
			A ¹⁾	B ²⁾	C ³⁾	E ^{4)/G⁵⁾}	K ^{6)/L⁷⁾}
BH	ATEX: II 3 G Ex ic IIC T6-T1 Gc	<ul style="list-style-type: none"> ■ FMR53 ■ FMR54 	XA00679F	XA00679F	XA00679F	XA00687F	XA00679F
BL	ATEX: II 1/2/3 G Ex nA [ia Ga] IIC T6-T1 Ga/Gb/Gc	<ul style="list-style-type: none"> ■ FMR53 ■ FMR54 	XA00678F	XA00678F	XA00678F	XA00686F	XA00678F
B2	ATEX: II 1/2 G Ex ia IIC T6-T1 Ga/Gb ATEX: II 1/2 D Ex ia IIIC Txx°C Da/Db	<ul style="list-style-type: none"> ■ FMR53 ■ FMR54 	XA00683F	XA00683F	XA00683F	XA00691F	-
B3	ATEX: II 1/2 G Ex d [ia] IIC T6-T1 Ga/Gb ATEX: II 1/2 D Ex ta IIIC Txx°C Da/Db	<ul style="list-style-type: none"> ■ FMR53 ■ FMR54 	XA00684F	XA00684F	XA00684F	XA00692F	XA00684F
B4	ATEX: II 1/2 G Ex ia IIC T6-T1 Ga/Gb ATEX: II 1/2 G Ex d [ia] IIC T6-T1 Ga/Gb	<ul style="list-style-type: none"> ■ FMR53 ■ FMR54 	XA00681F	XA00681F	XA00681F	XA00689F	-
CB	CSA C/US XP Cl.I Div.1 Gr.A-D	FMR54	XA01112F	XA01112F	XA01112F	XA01114F	-
CC	CSA C/US XP Cl.I Div.1 Gr.A-D	FMR54	XA01113F	XA01113F	XA01113F	XA01115F	XA01113F
C2	CSA C/US IS Cl.I,II,III Div.1 Gr.A-G, NI Cl.1 Div.2, Ex ia	<ul style="list-style-type: none"> ■ FMR53 ■ FMR54 	XA01112F	XA01112F	XA01112F	XA01114F	-
C3	CSA C/US XP Cl.I,II,III Div.1 Gr.A-G, NI Cl.1 Div.2, Ex d	<ul style="list-style-type: none"> ■ FMR53 ■ FMR54 	XA01113F	XA01113F	XA01113F	XA01115F	XA01113F
FA	FM IS Cl.I Div.1 Gr.A-D	FMR54	XA01116F	XA01116F	XA01116F	XA01118F	-
FB	FM IS Cl.I,II,III Div.1 Gr.A-G, AEx ia, NI Cl.1 Div.2	<ul style="list-style-type: none"> ■ FMR53 ■ FMR54 	XA01116F	XA01116F	XA01116F	XA01118F	-
FC	FM XP Cl.I Div.1 Gr.A-D	FMR54	XA01117F	XA01117F	XA01117F	XA01119F	XA01117F
FD	FM XP Cl.I,II,III Div.1 Gr.A-G, AEx d, NI Cl.1 Div.2	<ul style="list-style-type: none"> ■ FMR53 ■ FMR54 	XA01117F	XA01117F	XA01117F	XA01119F	XA01117F
IA	IECEX: Ex ia IIC T6-T1 Ga	<ul style="list-style-type: none"> ■ FMR53 ■ FMR54 	XA00677F	XA00677F	XA00677F	XA00685F	-
IB	IECEX: Ex ia IIC T6-T1 Ga/Gb	<ul style="list-style-type: none"> ■ FMR53 ■ FMR54 	XA00677F	XA00677F	XA00677F	XA00685F	-
IC	IECEX: Ex d [ia] IIC T6-T1 Ga/Gb	<ul style="list-style-type: none"> ■ FMR53 ■ FMR54 	XA00680F	XA00680F	XA00680F	XA00688F	XA00680F
ID	IECEX: Ex ic [ia Ga] IIC T6-T1 Ga/Gb/Gc	<ul style="list-style-type: none"> ■ FMR53 ■ FMR54 	XA00678F	XA00678F	XA00678F	XA00686F	XA00678F
IG	IECEX: Ex nA IIC T6-T1 Gc	<ul style="list-style-type: none"> ■ FMR53 ■ FMR54 	XA00679F	XA00679F	XA00679F	XA00687F	XA00679F
IH	IECEX: Ex ic IIC T6-T1 Gc	<ul style="list-style-type: none"> ■ FMR53 ■ FMR54 	XA00679F	XA00679F	XA00679F	XA00687F	XA00679F
IL	IECEX: Ex nA [ia Ga] IIC T6-T1 Ga/Gb/Gc	<ul style="list-style-type: none"> ■ FMR53 ■ FMR54 	XA00678F	XA00678F	XA00678F	XA00686F	XA00678F
I2	IECEX: Ex ia IIC T6-T1 Ga/Gb IECEX: Ex ia IIIC Txx°C Da/Db	<ul style="list-style-type: none"> ■ FMR53 ■ FMR54 	XA00683F	XA00683F	XA00683F	XA00691F	-
I3	IECEX: Ex d [ia] IIC T6-T1 Ga/Gb IEXEX: Ex ta IIIC Txx°C Da/Db	<ul style="list-style-type: none"> ■ FMR53 ■ FMR54 	XA00684F	XA00684F	XA00684F	XA00692F	XA00684F
I4	IECEX: Ex ia IIC T6-T1 Ga/Gb IECEX: Ex d [ia] IIC T6-T1 Ga/Gb	<ul style="list-style-type: none"> ■ FMR53 ■ FMR54 	XA00681F	XA00681F	XA00681F	XA00689F	-
JC	JPN Ex d [ia] IIC T4 Ga/Gb	<ul style="list-style-type: none"> ■ FMR53 ■ FMR54 	XA01717F	XA01717F	-	-	-
JD	JPN Ex d [ia] IIC T1 Ga/Gb	FMR54	XA01717F	XA01717F	-	-	-
JE	JPN Ex d [ia] IIC T2 Ga/Gb	FMR54	XA01717F	XA01717F			
KA	KC Ex ia IIC T6 Ga	<ul style="list-style-type: none"> ■ FMR53 ■ FMR54 	XA01045F	XA01045F	XA01045F	XA01047F	-
KB	KC Ex ia IIC T6 Ga/Gb	<ul style="list-style-type: none"> ■ FMR53 ■ FMR54 	XA01045F	XA01045F	XA01045F	XA01047F	-

Feature 010	Approval	Available for	Feature 020 "Power Supply; Output"				
			A ¹⁾	B ²⁾	C ³⁾	E ⁴⁾ /G ⁵⁾	K ⁶⁾ /L ⁷⁾
KC	KC Ex d[ia] IIC T6	<ul style="list-style-type: none"> ■ FMR53 ■ FMR54 	XA01046F	XA01046F	XA01046F	XA01048F	XA01046F
MA	INMETRO: Ex ia IIC T6 Ga	<ul style="list-style-type: none"> ■ FMR53 ■ FMR54 	XA01286F	XA01287F	XA01288F	XA01296F	-
MC	INMETRO: Ex d[ia] IIC T6 Ga/Gb	<ul style="list-style-type: none"> ■ FMR53 ■ FMR54 	XA01292F	XA01292F	XA01293F	XA01298F	XA01294F
MH	INMETRO: Ex ic IIC T6 Gc	<ul style="list-style-type: none"> ■ FMR53 ■ FMR54 	XA01289F	XA01290F	XA01291F	XA01297F	-
NA	NEPSI Ex ia IIC T6 Ga	<ul style="list-style-type: none"> ■ FMR53 ■ FMR54 	XA01199F	XA01199F	XA01199F	XA01208F	-
NB	NEPSI Ex ia IIC T6 Ga/Gb	<ul style="list-style-type: none"> ■ FMR53 ■ FMR54 	XA01199F	XA01199F	XA01199F	XA01208F	-
NC	NEPSI Ex d[ia] IIC T6 Ga/Gb	<ul style="list-style-type: none"> ■ FMR53 ■ FMR54 	XA01202F	XA01202F	XA01202F	XA01211F	XA01202F
NG	NEPSI Ex nA II T6 Gc	<ul style="list-style-type: none"> ■ FMR53 ■ FMR54 	XA01201F	XA01201F	XA01201F	XA01210F	XA01201F
NH	NEPSI Ex ic IIC T6 Gc	<ul style="list-style-type: none"> ■ FMR53 ■ FMR54 	XA01201F	XA01201F	XA01201F	XA01210F	XA01201F
N2	NEPSI Ex ia IIC T6 Ga/Gb, Ex iaD 20/21 T85...90oC	<ul style="list-style-type: none"> ■ FMR53 ■ FMR54 	XA01205F	XA01205F	XA01205F	XA01214F	-
N3	NEPSI Ex d[ia] IIC T6 Ga/Gb, DIP A20/21 T85...90oC IP66	<ul style="list-style-type: none"> ■ FMR53 ■ FMR54 	XA01206F	XA01206F	XA01206F	XA01215F	XA01206F
8A	FM/CSA IS+XP Cl.I,II,III Div.1 Gr.A-G	<ul style="list-style-type: none"> ■ FMR53 ■ FMR54 	<ul style="list-style-type: none"> ■ XA01112F ■ XA01113F ■ XA01116F ■ XA01117F 	<ul style="list-style-type: none"> ■ XA01112F ■ XA01113F ■ XA01116F ■ XA01117F 	<ul style="list-style-type: none"> ■ XA01112F ■ XA01113F ■ XA01116F ■ XA01117F 	<ul style="list-style-type: none"> ■ XA01114F ■ XA01115F ■ XA01118F ■ XA01119F 	-

- 1) 2-wire; 4-20mA HART
- 2) 2-wire; 4-20mA HART, switch output
- 3) 2-wire; 4-20mA HART, 4-20mA
- 4) 2-wire; FOUNDATION Fieldbus, switch output
- 5) 2-wire; PROFIBUS PA, switch output
- 6) 4-wire 90-253VAC; 4-20mA HART
- 7) 4-wire 10.4-48VDC; 4-20mA HART



For certified devices the relevant Safety Instructions (XA) are indicated on the nameplate.

If the device is prepared for the remote display FHX50 (product structure: feature 030: Display, Operation", option L or M), the Ex marking of some certificates changes according to the following table¹¹⁾:

Feature 010 ("Approval")	Feature 030 ("Display, Operation")	Ex marking
BG	L, M or N	ATEX II 3G Ex nA [ia Ga] IIC T6-T1 Gc
BH	L, M or N	ATEX II 3G Ex ic [ia Ga] IIC T6-T1 Gc
B3	L, M or N	ATEX II 1/2G Ex d [ia] IIC T6-T1 Ga/Gb, ATEX II 1/2D Ex ta [ia Db] IIIC Txx°C Da/Db
IG	L, M or N	IECEX Ex nA [ia Ga] IIC T6-T1 Gc
IH	L, M or N	IECEX Ex ic [ia Ga] IIC T6-T1 Gc
I3	L, M or N	IECEX Ex d [ia] IIC T6-T1 Ga/Gb, IECEX Ex ta [ia Db] IIIC Txx°C Da/Db

11) The marking of certificates not mentioned in this table are not affected by the FHX50.

Feature 010 ("Approval")	Feature 030 ("Display, Operation")	Ex marking
MH	L, M or N	Ex ic [ia Ga] IIC T6 Gc
NG	L, M or N	NEPSI Ex nA [ia Ga] IIC T6-T1 Gc
NH	L, M or N	NEPSI Ex ic [ia Ga] IIC T6-T1 Gc
N3	L, M or N	NEPSI Ex d [ia] IIC T6-T1 Ga/Gb, DIP A20/21 [ia D] TA, Txx°C IP6X



www.addresses.endress.com
