

Operating Instructions

Deltapilot S FMB70

Hydrostatic level measurement

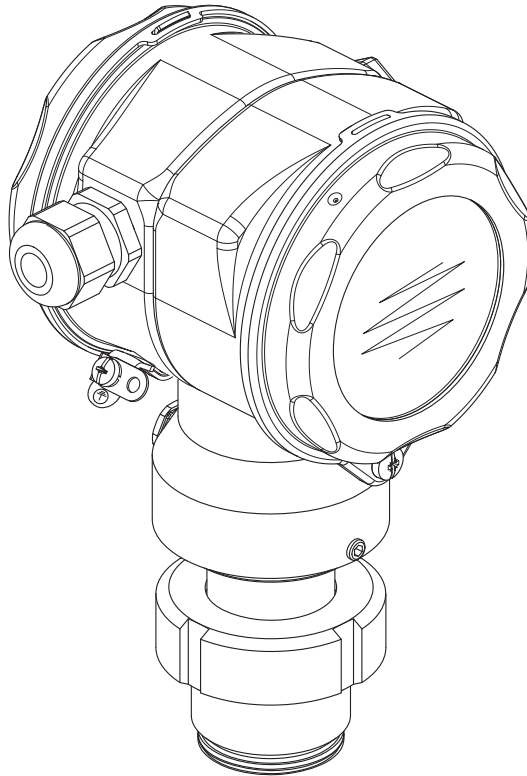

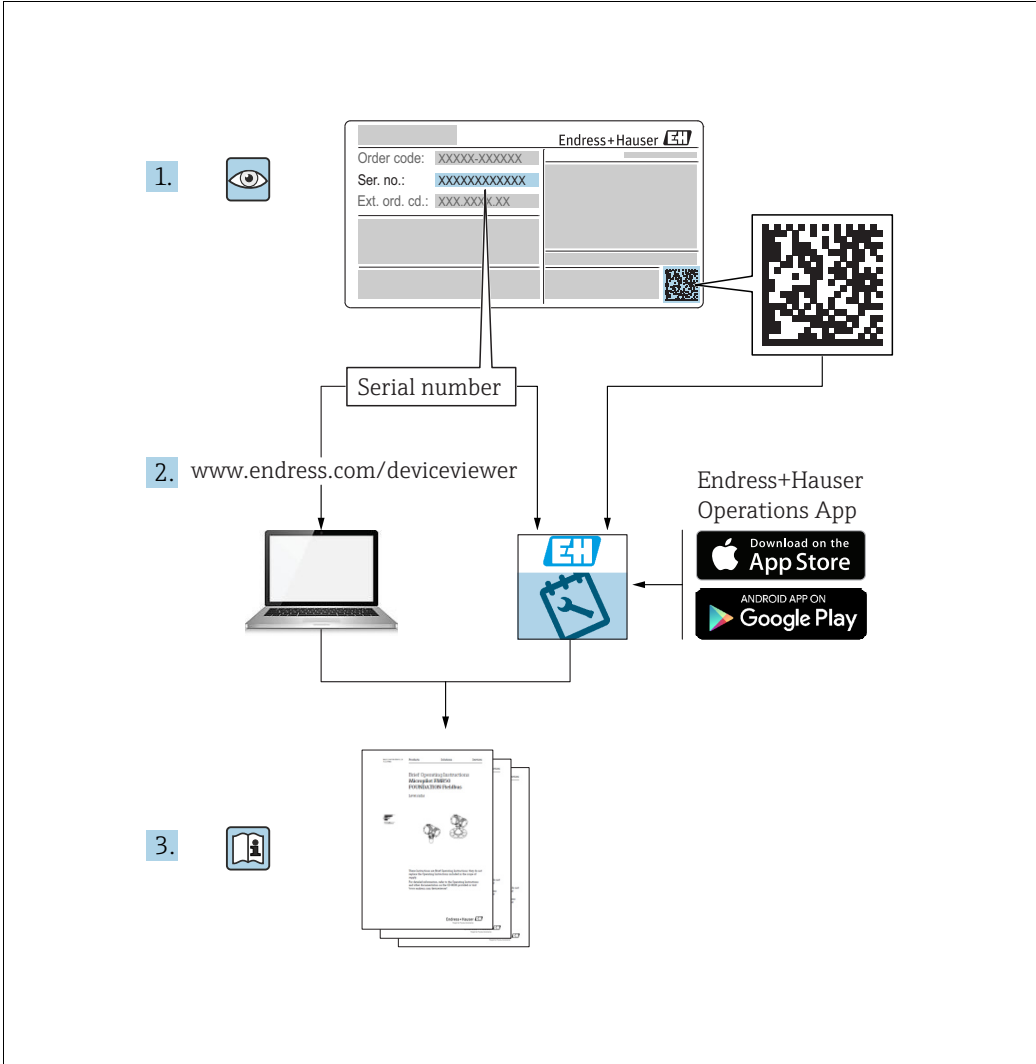

A0023555

Make sure the document is stored in a safe place such that it is always available when working on or with the device.
To avoid danger to individuals or the facility, read the "Basic safety instructions" section carefully, as well as all other safety instructions in the document that are specific to working procedures.
The manufacturer reserves the right to modify technical data without prior notice. Your Endress+Hauser Sales Center will supply you with current information and updates to these Instructions.

Table of contents

1	Document information	4	7.7	Pressure measurement	64
1.1	Document function	4	7.8	Scaling the OUT value	66
1.2	Symbols used	4	7.9	System units (SET UNIT TO BUS)	67
1.3	Registered trademarks	5	8	Maintenance	68
1.4	Terms and abbreviations	6	8.1	Exterior cleaning	68
1.5	Turn down calculation	7	9	Troubleshooting	69
2	Basic safety instructions	8	9.1	Messages	69
2.1	Requirements concerning the staff	8	9.2	Response of outputs to errors	77
2.2	Designated use	8	9.3	Confirming messages	79
2.3	Workplace safety	8	9.4	Repair	80
2.4	Operational safety	8	9.5	Repair of Ex-certified devices	80
2.5	Hazardous area	9	9.6	Spare Parts	80
2.6	Product safety	9	9.7	Return	80
3	Identification	10	9.8	Disposal	80
3.1	Product identification	10	9.9	Software history	81
3.2	Device designation	10	9.10	Hardware history	81
3.3	Scope of delivery	12	10	Technical data	81
3.4	CE mark, declaration of conformity	12		Index	82
4	Installation	13			
4.1	Incoming acceptance and storage	13			
4.2	Installation conditions	13			
4.3	General installation instructions	13			
4.4	Installation instructions	13			
4.5	Post-installation check	19			
5	Wiring	20			
5.1	Connecting the device	20			
5.2	Connecting the measuring unit	21			
5.3	Overvoltage protection (optional)	22			
5.4	Post-connection check	22			
6	Operation	23			
6.1	Onsite display (optional)	23			
6.2	Operating elements	24			
6.3	PROFIBUS PA communication protocol	27			
6.4	Onsite operation – onsite display connected	47			
6.5	FieldCare	50			
6.6	HistoROM®/M-DAT (optional)	50			
6.7	Locking/unlocking operation	53			
6.8	Factory setting (reset)	54			
7	Commissioning	56			
7.1	Configuring messages	56			
7.2	Function check	56			
7.3	Commissioning via Class 2 master (FieldCare)	57			
7.4	Selecting language and measuring mode	57			
7.5	Position adjustment	59			
7.6	Level measurement	60			





1 Document information

1.1 Document function







These Operating Instructions contain all the information that is required in various phases of the life cycle of the device: from product identification, incoming acceptance and storage, to mounting, connection, operation and commissioning through to troubleshooting, maintenance and disposal.

1.2 Symbols used



1.2.1 Safety symbols

Symbol	Meaning
 A0011189-DE	DANGER! This symbol alerts you to a dangerous situation. Failure to avoid this situation will result in serious or fatal injury.
 A0011190-DE	WARNING! This symbol alerts you to a dangerous situation. Failure to avoid this situation can result in serious or fatal injury.
 A0011191-DE	CAUTION! This symbol alerts you to a dangerous situation. Failure to avoid this situation can result in minor or medium injury.
 A0011192-DE	NOTICE! This symbol contains information on procedures and other facts which do not result in personal injury.









1.2.2 Electrical symbols

Symbol	Meaning	Symbol	Meaning
	Direct current		Alternating current
	Direct current and alternating current		Ground connection A grounded terminal which, as far as the operator is concerned, is grounded via a grounding system.
	Protective ground connection A terminal which must be connected to ground prior to establishing any other connections.		Equipotential connection A connection that has to be connected to the plant grounding system: This may be a potential equalization line or a star grounding system depending on national or company codes of practice.

1.2.3 Tool symbols

Symbol	Meaning
 A0011221	Allen key
 A0011222	Hexagon wrench

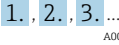
1.2.4 Symbols for certain types of information

Symbol	Meaning
 A0011182	Permitted Indicates procedures, processes or actions that are permitted.
 A0011184	Forbidden Indicates procedures, processes or actions that are forbidden.
 A0011193	Tip Indicates additional information.
 A0028658	Reference to documentation
 A0028659	Reference to page
 A0028660	Reference to graphic
 A0031595	Series of steps
 A0018343	Result of a sequence of actions
 A0028673	Visual inspection

1.2.5 Symbols in graphics

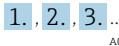
Symbol	Meaning
1, 2, 3, 4, ...	Item numbers
 A0031595	Series of steps
A, B, C, D, ...	Views

1.2.6 Symbols at the device

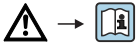
Symbol	Meaning
 A0019159	Safety instructions Observe the safety instructions contained in the associated Operating Instructions.

1.3 Registered trademarks

KALREZ, VITON, TEFLON
Registered trademarks of E.I. Du Pont de Nemours & Co., Wilmington, USA

TRI-CLAMP
Registered trademark of Ladish & Co., Inc., Kenosha, USA

PROFIBUS PA®
Trademark of the PROFIBUS User Organization, Karlsruhe, Germany

GORE-TEX®
Registered trademarks of W.L. Gore & Associates, Inc., USA

1.4 Terms and abbreviations

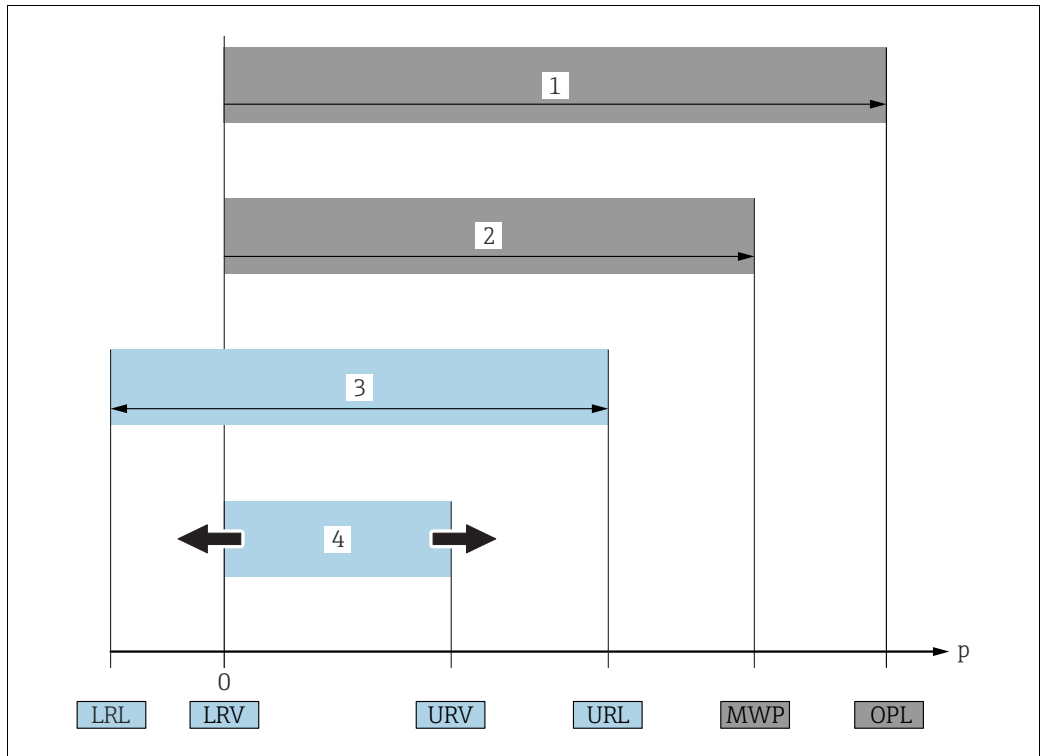

A0029505

Position	Term/Abbreviation	Explanation
1	OPL	The OPL (over pressure limit = sensor overload limit) for the sensors depends on the lowest-rated element, with regard to pressure, of the selected components, i.e. the process connection must be taken into consideration in addition to the measuring cell. Also observe pressure-temperature dependency. For the relevant standards and additional notes, see technical information. The OPL may be applied for a limited time period.
2	MWP	The MWP (maximum working pressure) for the sensors depends on the lowest-rated element, with regard to pressure, of the selected components, i.e. the process connection has to be taken into consideration in addition to the measuring cell. Also observe pressure-temperature dependency. For the relevant standards and additional notes, see technical information. The MWP may be applied for an unlimited time.
3	Maximum sensor measuring range	Range between LRL and URL This span is the maximum calibratable/adjustable measuring span.
4	Calibrated/Adjusted measuring span	Range between LRV and URV Factory setting: 0...URL Other calibrated spans can be ordered with customised settings.
p	-	Pressure
-	LRL	Lower range limit
-	URL	Upper range limit
-	LRV	Lower range value
-	URV	Upper range value
-	TD	Turn down

1.5 Turn down calculation

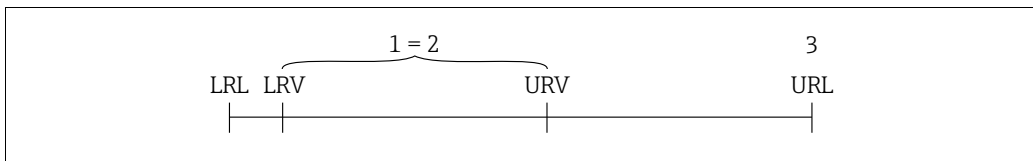

Fig. 1:

- 1 Calibrated/Adjusted measuring span
- 2 Zero-based span
- 3 Upper range limit

Example

- Sensor: 10 bar (150 psi)
- Upper range limit (URL) = 10 bar (150 psi)
- Calibrated/Adjusted measuring span: 0...5 bar (0...75 psi)
- Lower range value (LRV) = 0 bar
- Upper range value (URV) = 5 bar (75 psi)

Turn down (TD):

$$TD = \frac{URL}{|URV - LRV|}$$

$$TD = \frac{10 \text{ bar (150 psi)}}{|5 \text{ bar (75 psi)} - 0 \text{ bar (0 psi)}|} = 2$$

In this example, the TD is thus 2:1.
This span is based on the zero point.

2 Basic safety instructions

2.1 Requirements concerning the staff

The personnel for installation, commissioning, diagnostics and maintenance must fulfill the following requirements:

- Trained, qualified specialists: must have a relevant qualification for this specific function and task
- Are authorized by the plant owner/operator
- Are familiar with federal/national regulations
- Before beginning work, the specialist staff must have read and understood the instructions in the Operating Instructions and supplementary documentation as well as in the certificates (depending on the application)
- Following instructions and basic conditions

The operating personnel must fulfill the following requirements:

- Being instructed and authorized according to the requirements of the task by the facility's owner-operator
- Following the instructions in these Operating Instructions

2.2 Designated use

The Deltapilot S is a hydrostatic pressure transmitter for measuring level and pressure.

2.2.1 Incorrect use

The manufacturer is not liable for damage caused by improper or non-designated use.

Verification for borderline cases:

For special fluids and fluids for cleaning, Endress+Hauser is glad to provide assistance in verifying the corrosion resistance of fluid-wetted materials, but does not accept any warranty or liability.

2.3 Workplace safety

For work on and with the device:

- Wear the required personal protective equipment according to federal/national regulations.
- Switch off the supply voltage before connecting the device.

2.4 Operational safety

Risk of injury!

- ▶ Operate the device in proper technical condition and fail-safe condition only.
- ▶ The operator is responsible for interference-free operation of the device.

Conversions to the device

Unauthorized modifications to the device are not permitted and can lead to unforeseeable dangers:

- ▶ If, despite this, modifications are required, consult with Endress+Hauser.

Repair

To ensure continued operational safety and reliability,

- ▶ Carry out repairs on the device only if they are expressly permitted.
- ▶ Observe federal/national regulations pertaining to repair of an electrical device.
- ▶ Use original spare parts and accessories from Endress+Hauser only.

2.5 Hazardous area

To eliminate a danger for persons or for the facility when the device is used in the hazardous area (e.g. explosion protection, pressure vessel safety):

- Based on the nameplate, check whether the ordered device is permitted for the intended use in the hazardous area.
- Observe the specifications in the separate supplementary documentation that is an integral part of these Instructions.

2.6 Product safety

This measuring device is designed in accordance with good engineering practice to meet state-of-the-art safety requirements, has been tested, and left the factory in a condition in which they are safe to operate. It fulfills general safety requirements and legal requirements. It also conforms to the EC directives listed in the device-specific EC declaration of conformity. Endress+Hauser confirms this fact by applying the CE mark.

3 Identification

3.1 Product identification

The following options are available for identification of the measuring device:

- Nameplate specifications
- Order code with breakdown of the device features on the delivery note
- Enter serial numbers from nameplates in W@M Device Viewer (www.endress.com/deviceviewer): All information about the measuring device is displayed.

For an overview of the technical documentation provided, enter the serial number from the nameplates in the W@M Device Viewer (www.endress.com/deviceviewer).

3.2 Device designation

3.2.1 Nameplate

- The MWP (maximum working pressure) is specified on the nameplate. This value refers to a reference temperature of +20 °C (68°F) and may be applied to the device for an unlimited time. Observe temperature dependency of the MWP. The pressure values permitted at higher temperatures can be found in the standards EN 1092-1: 2001 Tab. 18 (With regard to their stability-temperature property, the materials 1.4435 and 1.4404 are grouped together under 13EO in EN 1092-1 Tab. 18. The chemical composition of the two materials can be identical.), ASME B 16.5a – 1998 Tab. 2-2.2 F316, ASME B 16.5a – 1998 Tab. 2.3.8 N10276, JIS B 2220.
- The test pressure corresponds to the over pressure limit (OPL) of the device = MWP x 1.5.
- The Pressure Equipment Directive (2014/68/EU) uses the abbreviation "PS". The abbreviation "PS" corresponds to the MWP (maximum working pressure) of the measuring device.

Aluminum housing (T14/T15)

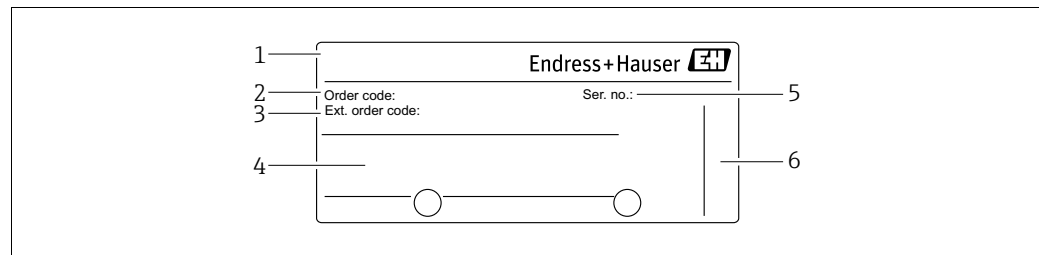

Fig. 2: Nameplate

- | | |
|---|------------------------------------|
| 1 | Device name |
| 2 | Order code (for re-orders) |
| 3 | Extended order code (complete) |
| 4 | Technical data |
| 5 | Serial number (for identification) |
| 6 | Address of manufacturer |

Devices for use in hazardous areas are fitted with an additional nameplate.

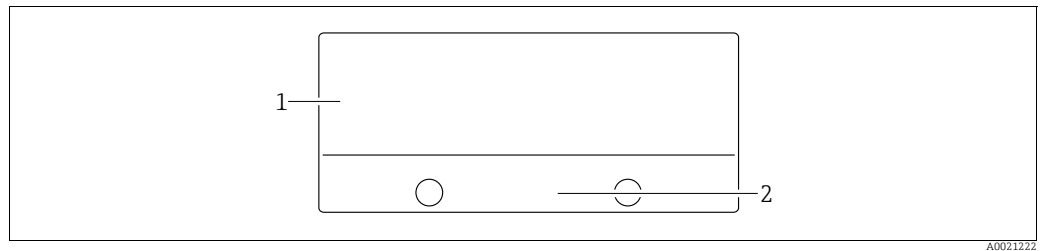

Fig. 3: Additional nameplate

- 1 Approval-specific information
- 2 Document number for safety instructions or drawing number

Hygienic stainless steel housing (T17)

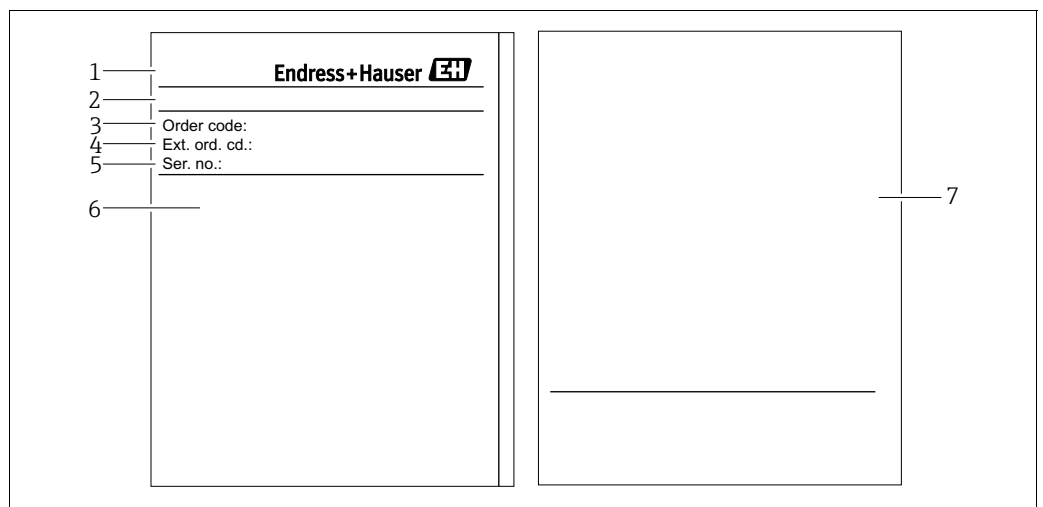

Fig. 4: Nameplate

- 1 Device name
- 2 Address of manufacturer
- 3 Order code (for re-orders)
- 4 Extended order code (complete)
- 5 Serial number (for identification)
- 6 Technical data
- 7 Approval-specific information and document number for safety instructions or drawing number

3.2.2 Identifying the sensor type

See parameter "Sensor Meas.Type" in Operating Instruction BA00296P.

3.3 Scope of delivery

The scope of delivery comprises:

- Deltapilot S hydrostatic pressure transmitter
- For devices with the "HistoROM/M-DAT" option:
CD-ROM with FieldCare operating program
- Optional accessories

Documentation supplied:

- The Operating Instructions BA00356P and BA00296P are available via the Internet.
→ See: www.endress.com → Download.
- Brief Operating Instructions KA01023P
- Leporello KA00244P
- Final inspection report
- Also Safety Instructions with devices for use in hazardous areas
- Optional: factory calibration certificate, test certificates

3.4 CE mark, declaration of conformity

The device is designed to meet state-of-the-art safety requirements, has been tested and left the factory in a condition in which it is safe to operate. The device complies with the applicable standards and regulations as listed in the EC declaration of conformity and thus complies with the statutory requirements of the EC Directives. Endress+Hauser confirms the successful testing of the device by affixing to it the CE mark.

4 Installation

4.1 Incoming acceptance and storage

4.1.1 Incoming acceptance

- Check the packaging and the contents for damage.
- Check the shipment, make sure nothing is missing and that the scope of supply matches your order.

4.1.2 Transport

▲ WARNING

Incorrect transportation

Housing and diaphragm may become damaged, and there is a risk of injury!

- ▶ Transport the measuring device to the measuring point in its original packaging or by the process connection (with secure transport protection for the diaphragm).
- ▶ Follow the safety instructions and transport conditions for devices weighing more than 18 kg (39.6 lbs).

4.1.3 Storage

The device must be stored in a dry, clean area and protected against impact (EN 837-2).

Storage temperature range:

- -40 to +90°C (-40 to +194°F)
- Onsite display: -40 to +85°C (-40 to +185°F)
- Separate housing: -40 to +60°C (-40 to +140°F)

4.2 Installation conditions

4.2.1 Dimensions

→ For dimensions, please refer to the Technical Information for Deltapilot S TI00416P, "Mechanical construction" section.

4.3 General installation instructions

- Devices with a G 1 1/2 thread:
When screwing the device into the tank, the flat seal has to be positioned on the sealing surface of the process connection. To avoid additional strain on the process isolating diaphragm, the thread should never be sealed with hemp or similar materials.
- Devices with NPT threads:
 - Wrap Teflon tape around the thread to seal it.
 - Tighten the device at the hexagonal bolt only. Do not turn at the housing.
 - Do not overtighten the thread when screwing. Max. torque: 20 to 30 Nm (14.75 to 22.13 lbf ft)

4.4 Installation instructions

- Due to the orientation of the Deltapilot S, there may be a shift in the measured value, i.e. when the container is empty, the measured value does not display zero. You can correct this zero point shift either via the "zero" key on the electronic insert, or on the outside of the device or via the onsite display. →  24, Kap. 6.2.1 "Position of operating elements",

- 25, Kap. 6.2.2 "Function of operating elements – onsite display not connected" and
- 59, Kap. 7.5 "Position adjustment".
- To ensure optimal readability of the onsite display, it is possible to rotate the housing up to 380°. → 18, Section 4.4.5 "Rotating the housing".
- Endress+Hauser offers a mounting bracket for installing on pipes or walls.
 - 16, Section 4.4.3 "Wall and pipe mounting (optional)".

4.4.1 Installation instructions

NOTICE

Damage to the device!

If a heated Deltapilot S is cooled during the cleaning process (e.g. by cold water), a vacuum develops for a short time, whereby moisture can penetrate the sensor through the pressure compensation (1).

- ▶ If this is the case, mount the sensor with the pressure compensation (1) pointing downwards.

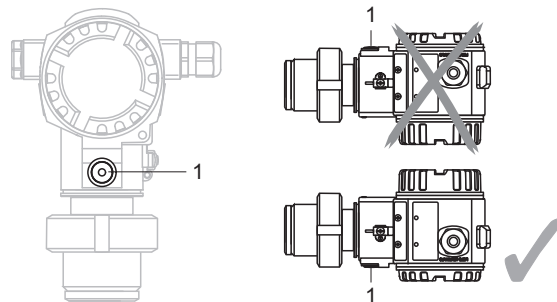

- Keep the pressure compensation and GORE-TEX® filter (1) free from contamination.
- Do not clean or touch process isolating diaphragm with hard or pointed objects.
- The device must be installed as follows in order to comply with the cleanability requirements of the ASME-BPE (Part SD Cleanability):

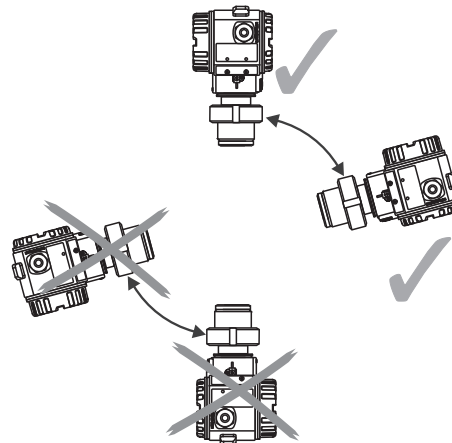

Level measurement

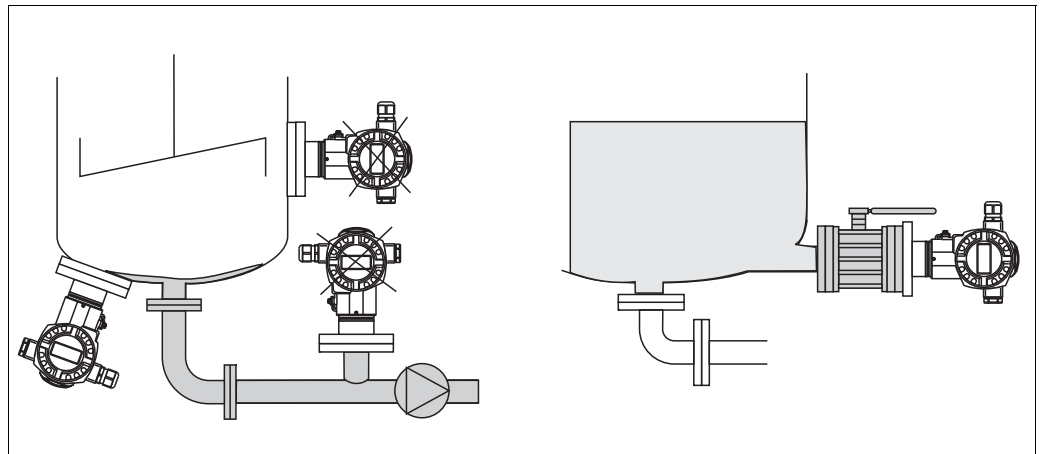

Fig. 5: Measuring arrangement for level

P01-PMP75xxx-11-xx-xx-xx-000

- Always install the device below the lowest measuring point.
- Do not install the device at the following positions:
 - in the filling curtain
 - in the tank outflow
 - in the suction area of a pump
 - or at a point in the tank that can be affected by pressure pulses from the agitator
- The calibration and functional test can be carried out more easily if you mount the device downstream of a shutoff device.
- Deltapilot S must be included in the insulation for media that can harden when cold.

Pressure measurement in gases

- Mount Deltapilot S with shutoff device above the tapping point so that any condensate can flow into the process.

Pressure measurement in steams

- Mount Deltapilot S with siphon above the tapping point.
- Fill the siphon with liquid before commissioning.
The siphon reduces the temperature to almost the ambient temperature.

Pressure measurement in liquids

- Mount Deltapilot S with the shutoff device below or at the same level as the tapping point.

4.4.2 Seal for flange mounting

NOTICE

Corrupted measurement results.

The seal is not allowed to press against the process isolating diaphragm as this could affect the measurement result.

- ▶ Ensure that the seal is not touching the process isolating diaphragm.

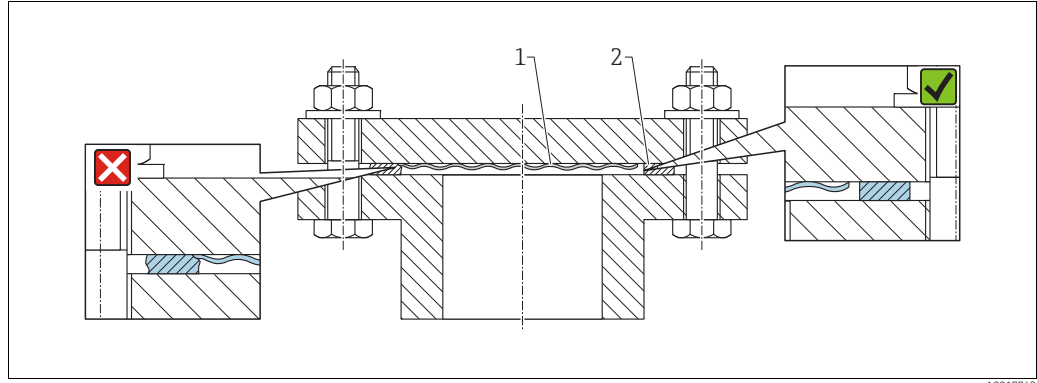
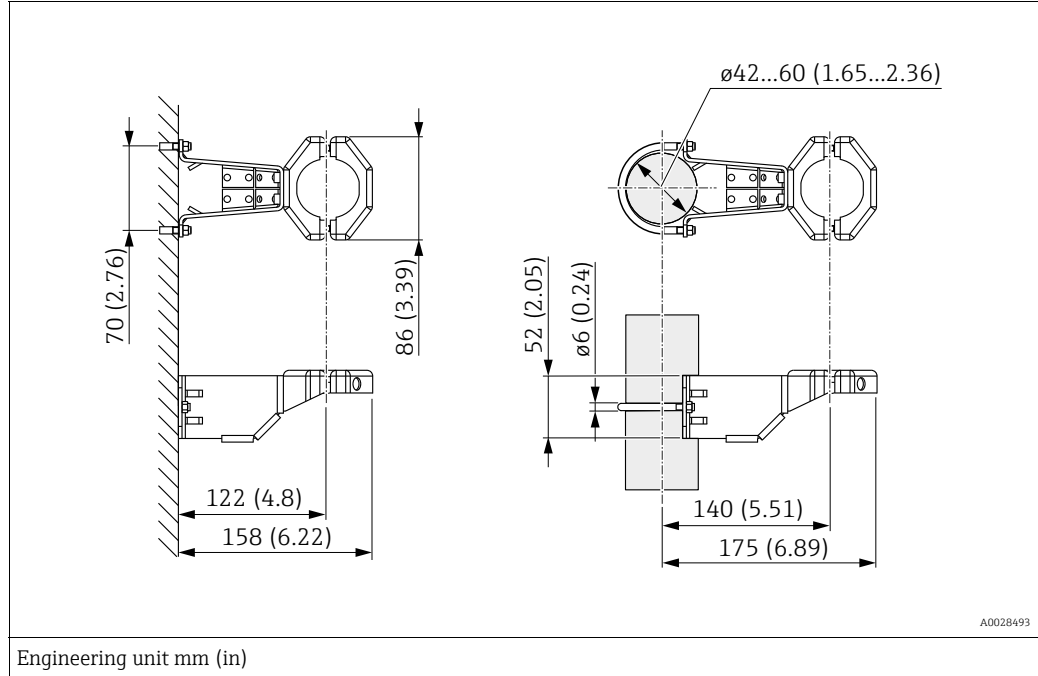

Fig. 6:
 1 Process isolating diaphragm
 2 Seal

4.4.3 Wall and pipe mounting (optional)

Endress+Hauser offers a mounting bracket for installation on pipes or walls (for pipe diameters from 1 ¼" to 2").



Please note the following when mounting:

- Devices with capillary tubes: mount capillaries with a bending radius ≥ 100 mm (3.94 in).
- When mounting on a pipe, tighten the nuts on the bracket uniformly with a torque of at least 5 Nm (3.69 lbs ft).

4.4.4 Assembling and mounting the "separate housing" version

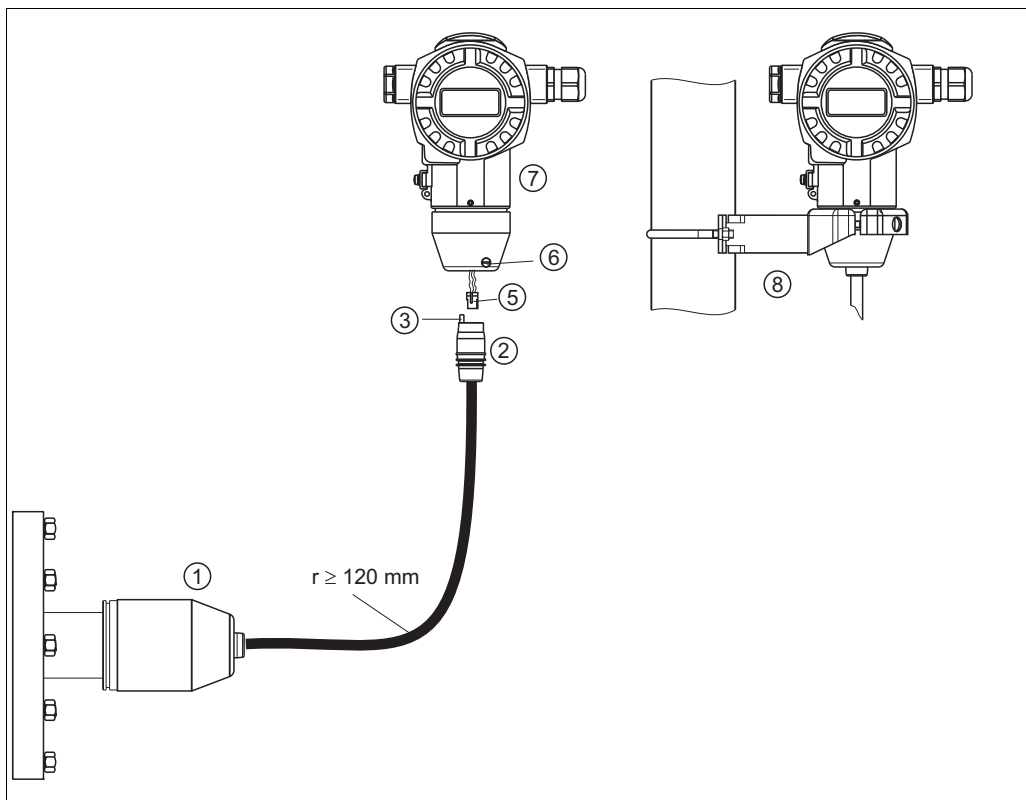

P01-FMB70xxx-11-xx-xx-xx-003

Fig. 7: "Separate housing" version

- 1 In the "separate housing" version, the sensor is supplied with process connection and cable fitted.
- 2 Cable with connection jack
- 3 Pressure compensation
- 5 Plug
- 6 Locking screw
- 7 Housing fitted with housing adapter, included
- 8 Mounting bracket suitable for wall and pipe mounting, included

Assembly and mounting

1. Connect plug (item 5) into the corresponding connection jack of the cable (item 2).
2. Plug the cable into the housing adapter (item 7).
3. Tighten the locking screw (item 6).
4. Mount the housing on a wall or pipe using the mounting bracket (item 8).
In the case of pipe mounting, the nuts on the bracket must be tightened uniformly with a torque of at least 5 Nm (3.69 lbs ft).
Mount the cable with a bending radius (r) ≥ 120 mm (4.72 in).

4.4.5 Rotating the housing

The housing can be rotated up to 380° by loosening the Allen screw.

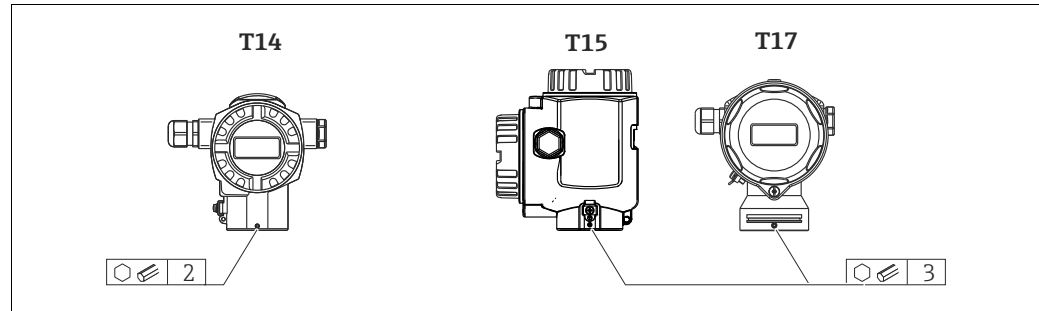

A0019996

1. T14 housing: Loosen setscrew with a 2 mm (0.08 in) Allen key.
T15 and T17 housing: Loosen setscrew with a 3 mm (0.12 in) Allen key.
2. Rotate housing (max. up to 380°).
3. Retighten setscrew with 1 Nm (0,74 lbf ft).

4.4.6 Closing the housing cover

NOTICE

Devices with EPDM cover seal - transmitter leakiness!

Mineral-based, animal-based or vegetable-based lubricants cause the EPDM cover seal to swell and the transmitter to become leaky.

- ▶ The thread is coated at the factory and therefore does not require any lubrication.

NOTICE

The housing cover can no longer be closed.

Damaged thread!

- ▶ When closing the housing cover, please ensure that the thread of the cover and housing are free from dirt, e.g. sand. If you feel any resistance when closing the cover, check the thread on both again to ensure that they are free from dirt.

Close cover on a hygienic stainless steel housing (T17)

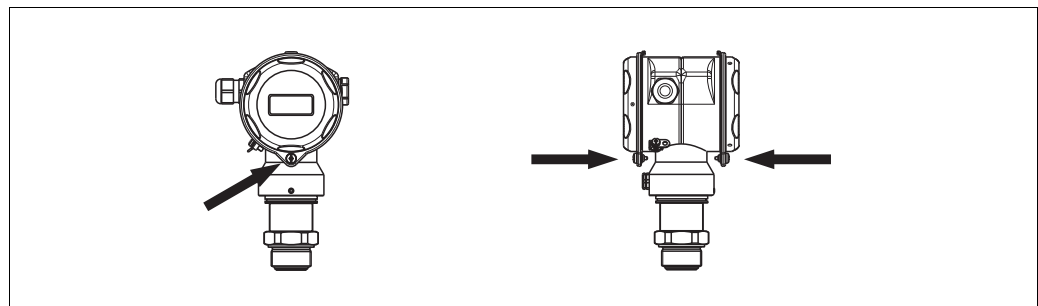

P01-FMB70xxx-17-xx-xx-xx-001

Fig. 8: Close cover

The covers for the terminal and electronics compartment are hooked into the casing and closed with a screw. These screws should be finger-tightened (2 Nm (1.48 lbf ft)) to the stop to ensure that the covers sit tightly.

4.4.7 Mounting of the profile seal for universal process mounting adapter

For details on mounting, see KA00096F/00/A3.

4.5 Post-installation check

After installing the device, carry out the following checks:

- Are all screws firmly tightened?
- Are the housing covers screwed down tight?

5 Wiring

5.1 Connecting the device

⚠ WARNING

Risk of electric shock!

If the operating voltage is > 35 VDC: Dangerous contact voltage at terminals.

- ▶ In a wet environment, do not open the cover if voltage is present.

⚠ WARNING

Limitation of electrical safety due to incorrect connection!

- Risk of electric shock and/or explosion in hazardous areas! In a wet environment, do not open the cover if voltage is present.
- When using the measuring device in hazardous areas, installation must comply with the corresponding national standards and regulations and the Safety Instructions or Installation or Control Drawings.
- Devices with integrated overvoltage protection must be earthed.
- Protective circuits against reverse polarity, HF influences and overvoltage peaks are installed.
- The supply voltage must match the supply voltage on the nameplate. (→ 10, Kap. 3.2.1 "Nameplate")
- Switch off the supply voltage before connecting the device.
- Remove housing cover of the terminal compartment.
- Guide cable through the gland. → For cable specification → 22, Kap. 6.2.3.
- Connect device in accordance with the following diagram.
- Screw down housing cover.
- Switch on supply voltage.

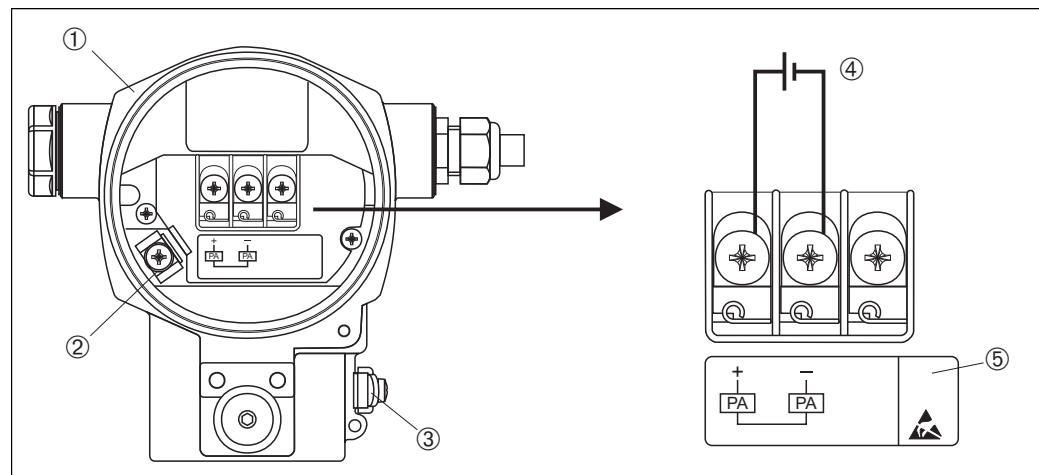
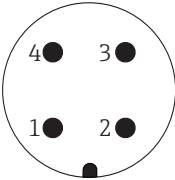

Fig. 9: Electrical connection of PROFIBUS PA
→ Please refer also to → 21, Kap. 5.2.1 "Supply voltage".

- 1 Housing
- 2 Internal earth terminal
- 3 External earth terminal
- 4 Supply voltage, for version in non-hazardous area = 9...32 VDC
- 5 Devices with integrated overvoltage protection are labeled OVP (overvoltage protection) here.

5.1.1 Connecting devices with an M12 connector

PIN assignment for M12 connector	PIN	Meaning
	1	Signal +
	2	Not assigned
	3	Signal -
	4	Earth

5.1.2 Connecting devices with 7/8" plug

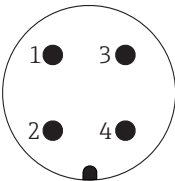
PIN assignment for 7/8" connector	PIN	Meaning
	PIN	Meaning
	1	Signal -
	2	Signal +
	3	Shield
	4	Not assigned

5.1.3 Connecting the cable version

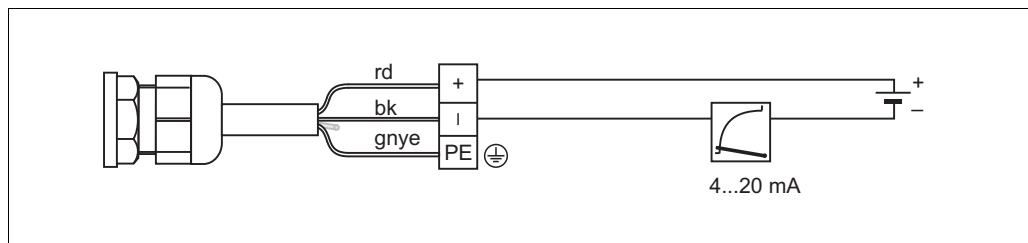

Fig. 10: rd = red, bk = black, gnye = green-yellow

P01-PMx4xxxx-04-xxx-xx-xx-010

5.2 Connecting the measuring unit

For further information on the network structure and grounding and for further bus system components such as bus cables, see the relevant documentation, e.g. Operating Instructions BA00034S "Guidelines for planning and commissioning PROFIBUS DP/PA" and the PNO Guideline.

5.2.1 Supply voltage

⚠ WARNING

Supply voltage might be connected!

Risk of electric shock and/or explosion!

- ▶ When using the measuring device in hazardous areas, installation must comply with the corresponding national standards and regulations and the Safety Instructions or Installation or Control Drawings.
- ▶ All explosion protection data are given in separate documentation which is available upon request. The Ex documentation is supplied as standard with all devices approved for use in explosion hazardous areas.

Version for non-hazardous area: 9...32 V DC

5.2.2 Current consumption

Up to HW Version 1.10: 11 mA \pm 1 mA, switch-on current corresponds to IEC 61158-2, Clause 21.

As of HW Version 02.00: 13 mA \pm 1 mA, switch-on current corresponds to IEC 61158-2, Clause 21.

As of Hardware Version 1.10, you will find a label in the device on the electronic insert.

5.2.3 Terminals

- Supply voltage and internal ground terminal: 0.5 to 2.5 mm² (20 to 14 AWG)
- External ground terminal: 0.5 to 4 mm² (20 to 12 AWG)

5.2.4 Cable specification

- Use a twisted, shielded two-wire cable, preferably cable type A.
- Outer cable diameter: 5 to 9 mm (0.2 to 0.35 in)

For further information on the cable specifications, see Operating Instructions BA00034S "Guidelines for planning and commissioning PROFIBUS DP/PA", PNO Guideline 2.092 "PROFIBUS PA User and Installation Guideline" and IEC 61158-2 (MBP).

5.2.5 Grounding and shielding

Deltapilot S must be earthed, for example by means of the external earth terminal.

Different grounding and shielding installation methods are available for PROFIBUS PA networks such as:

- Isolated installation (see also IEC 61158-2)
- Installation with multiple grounding
- Capacitive installation

5.3 Overvoltage protection (optional)

NOTICE

Device could be destroyed!

Devices with integrated overvoltage protection must be earthed.

Devices showing version "M" in feature 100 "Additional options 1" or feature 110 "Additional options 2" in the order code are equipped with overvoltage protection (→ see also Technical Information TI00416P "Ordering information").

- Overvoltage protection:
 - Nominal functioning DC voltage: 600 V
 - Nominal discharge current: 10 kA
- Surge current check $\hat{i} = 20$ kA as per DIN EN 60079-14: 8/20 μ s satisfied
- Arrester AC current check $I = 10$ A satisfied

5.4 Post-connection check

Perform the following checks after completing electrical installation of the device:

- Does the supply voltage match the specifications on the nameplate?
- Is the device connected as per Section 4.1?
- Are all screws firmly tightened?
- Are the housing covers screwed down tight?

As soon as voltage is applied to the device, the green LED on the electronic insert lights up for a few seconds or the connected onsite display lights up.

6 Operation

Feature 20 "Output; operation" in the order code provides you with information on the operating options available to you.

Versions in the order code		Operation
M	PROFIBUS PA; external and LCD	Via onsite display and 1 key on the exterior of the device
N	PROFIBUS PA; internal and LCD	Via onsite display and 1 key on the inside of the device
O	PROFIBUS PA; internal	Without onsite display, 1 key on the inside of the device

6.1 Onsite display (optional)

A 4-line liquid crystal display (LCD) is used for display and operation. The onsite display shows measured values, fault messages and notice messages.

The display of the device can be turned in 90° steps.

Depending on the installation position of the device, this makes it easy to operate the device and read the measured values.

Functions:

- 8-digit measured value display including sign and decimal point, unit display
- Bar Graph as graphic display of standardized value of the Analog Input Block (→ see also graphic, → 66, Kap. 7.8 "Scaling the OUT value")
- Simple and complete menu guidance thanks to separation of the parameters into several levels and groups
- Menu guidance in 8 languages (de, en, fr, es it, nl, jp, ch)
- Each parameter is given a 3-digit ID number for easy navigation
- Option for configuring the display according to individual requirements and desires, such as language, alternating display, contrast setting, display of other measured values such as sensor temperature
- Comprehensive diagnostic functions (fault and warning message, drag needle, etc.)
- rapid and safe commissioning with the Quick Setup menus

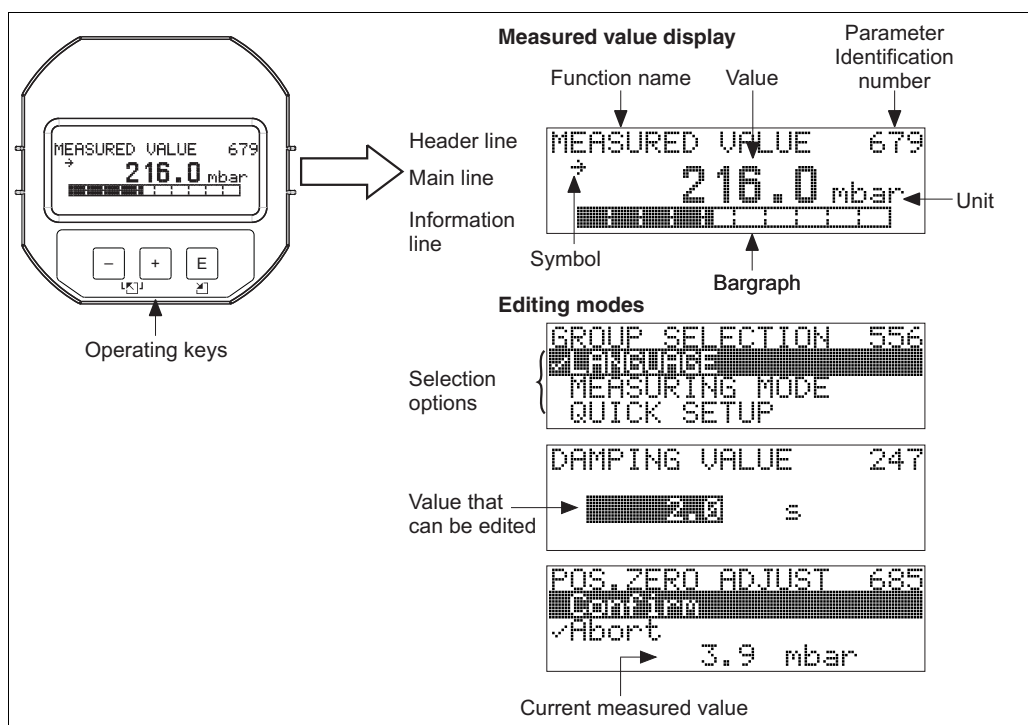

P01-xxxxxxx-07-xx-xx-xx-011

The following table illustrates the symbols that can appear on the onsite display. Four symbols can occur at one time.

Symbol	Meaning
	Alarm symbol – Symbol flashing: warning, device continues measuring. – Symbol permanently lit: error, device does not continue measuring. <i>Note:</i> The alarm symbol may overlie the tendency symbol.
	Lock symbol The operation of the device is locked. To unlock the device, → 53, Kap. 6.7 "Locking/unlocking operation".
	Communication symbol Data transfer via communication
	Tendency symbol (increasing) The primary value of the Transducer Block is increasing.
	Tendency symbol (decreasing) The primary value of the Transducer Block is decreasing.
	Tendency symbol (constant) The primary value of the Transducer Block has remained constant over the past few minutes.

6.2 Operating elements

6.2.1 Position of operating elements

With regard to aluminum housings (T14/T15), the operating key is located either outside the device under the protection cap or inside on the electronic insert. In hygienic stainless steel housings (T17), the operating key is always located inside on the electronic insert. Additionally, three operating keys are located on the optional onsite display.

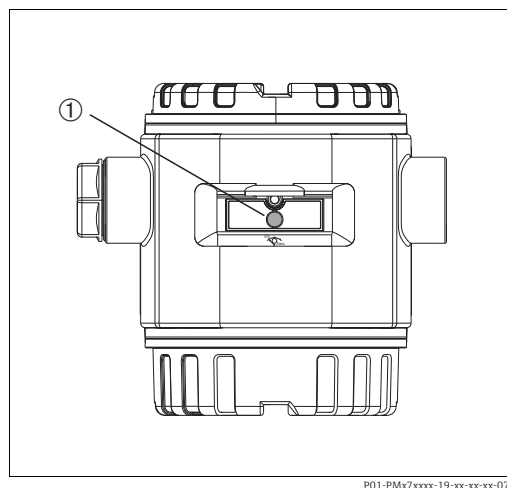

Fig. 11: Operating key external, under the protective flap

- 1 Operating key for position adjustment (zero point correction) and total reset

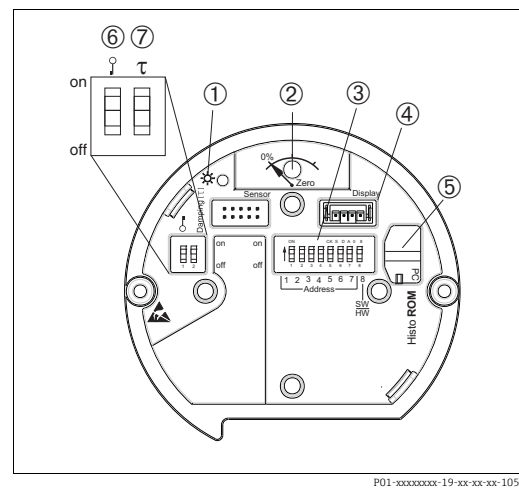
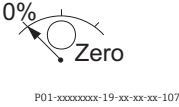
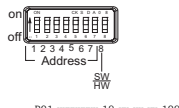
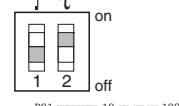

Fig. 12: Operating key and operating elements, internal

- 1 Green LED to indicate value is accepted
- 2 Operating key for position adjustment (zero point correction) and total reset
- 3 DIP switch for hardware address
- 4 Slot for optional display
- 5 Slot for optional HistoROM®/M-DAT
- 6 DIP-switch for locking/unlocking measured-value-relevant parameters
- 7 DIP-switch for damping on/off

6.2.2 Function of operating elements – onsite display not connected

Operating elements	Meaning
 <p>P01-xxxxxxx-19-xx-xx-xx-107</p>	<ul style="list-style-type: none"> - Position adjustment (zero point correction): Press key for at least 3 seconds. If the LED on the electronic insert lights up briefly, the pressure applied has been accepted for position adjustment. → See also the following section "Performing position adjustment onsite". - Total reset: Press key for at least 12 seconds. If the LED on the electronic insert lights up briefly, the reset is being carried out.
 <p>P01-xxxxxxx-19-xx-xx-xx-109</p>	<p>Set address in the bus. → 30, Kap. 6.3.5, "Device identification and addressing".</p>
 <p>P01-xxxxxxx-19-xx-xx-xx-108</p>	<ul style="list-style-type: none"> - DIP-switch 1: for locking/unlocking measured-value-relevant parameters Factory setting: off (unlocked) → 53, Kap. 6.7 "Locking/unlocking operation". - DIP switch 2: damping on/off Factory setting: on (damping on)



Performing position adjustment onsite

- The operation must be unlocked. → 53, Kap. 6.7 "Locking/unlocking operation".
- The device is configured for the Pressure measuring mode as standard. You can switch measuring modes by means of the MEASURING MODE parameter. → 57, Kap. 7.4 "Selecting language and measuring mode".
- The pressure applied must be within the nominal pressure limits of the sensor. See information on the nameplate.

Carry out position adjustment:

1. Pressure is present at device.
2. Press key for at least 3 seconds.
3. If the LED on the electronic insert lights up briefly, the pressure applied has been accepted for position adjustment.
If the LED does not light up, the pressure applied was not accepted. Observe the input limits. → For error messages → 69, Kap. 9.1 "Messages".

6.2.3 Function of the operating elements – onsite display connected

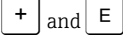
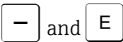
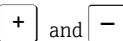
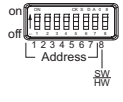
Operating key(s)	Meaning
	<ul style="list-style-type: none"> - Navigate upwards in the picklist - Edit the numerical values and characters within a function
	<ul style="list-style-type: none"> - Navigate downwards in the picklist - Edit the numerical values and characters within a function
	<ul style="list-style-type: none"> - Confirm entry - Jump to the next item
	Contrast setting of onsite display: darker
	Contrast setting of onsite display: brighter
	ESC functions: <ul style="list-style-type: none"> - Exit edit mode without saving the changed value. - You are in a menu within a function group. The first time you press the keys simultaneously, you go back a parameter within the function group. Each time you press the keys simultaneously after that, you go up a level in the menu. - You are in a menu at a selection level. Each time you press the keys simultaneously, you go up a level in the menu. Note: The terms function group, level and selection level are explained → 47, Kap. 6.4.1 ".
 <p style="font-size: small; margin-top: 5px;">P01-xxxxxxxx-19-xx-xx-xx-109</p>	Set address in the bus. → 30, Kap. 6.3.5 "Device identification and addressing".

6.3 PROFIBUS PA communication protocol

6.3.1 System architecture

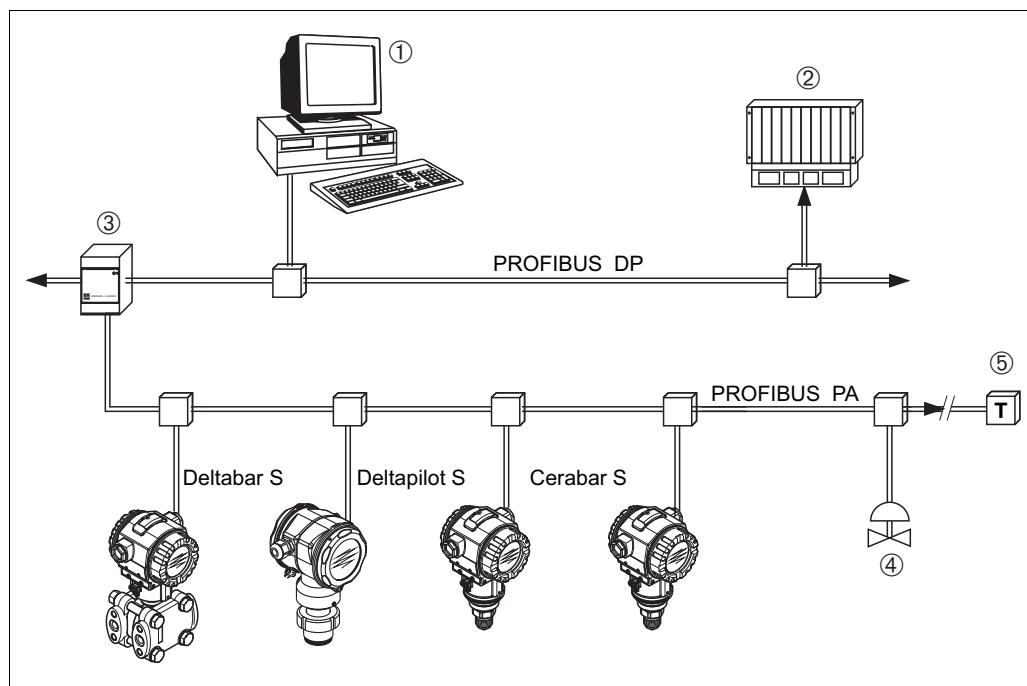

Fig. 13: PROFIBUS system architecture

- 1 PC with PROFIBUS interface card (Profiboard/Proficard) and operating program FieldCare (Class 2 master)
- 2 PLC (Class 1 master)
- 3 Segment coupler (DP/PA signal converter and bus feed unit)
- 4 Other measuring devices and adjusters such as valves
- 5 PROFIBUS PA terminating resistor

Further information on PROFIBUS PA can be found in Operating Instructions BA00034S "Guidelines for planning and commissioning PROFIBUS DP/PA", the PNO Guideline and standards IEC 61158, IEC 61784, EN 50170/DIN 19245 and EN 50020 (FISCO model).

6.3.2 Number of devices

- Endress+Hauser Deltapilot S devices meet the requirements specified of the FISCO model.
- Due to the low current consumption, the following can be operated at one bus segment when installation is performed according to FISCO:

Up to HW Verion 1.10:

- Up to 9 Deltapilot S for Ex ia, CSA and FM IS applications
- Up to 32 Deltapilot S in all other applications, e.g. in non-Ex areas, Ex nA etc.

As of HW Verion 02.00:

- Up to 7 Deltapilot S for Ex ia, CSA and FM IS applications
- Up to 27 Deltapilot S in all other applications, e.g. in non-Ex areas, Ex nA etc.

The maximum number of measuring devices at one bus segment is defined by their current consumption, the performance of the bus coupler, and the required bus length.

As of Hardware Version 1.10, you will find a label in the device on the electronic insert.

6.3.3 Operation

Special configuration and operating programs from various manufacturers are available for configuring the device, such as the Endress+Hauser operating program FieldCare (→ 47, Kap. 6.4). This operating program makes it possible to configure PROFIBUS PA and the device-specific parameters. The predefined function blocks allow uniform access to all the network and device data.

6.3.4 Identification number of the device

The "IDENT NUMBER SEL." parameter allows users to modify the identification number. The identification number "IDENT NUMBER SEL." must support the following settings:

Values for "IDENT NUMBER SEL."	Description
0 "0x9700"	Profile-specific transmitter identification number with the "Classic" or "Condensed" status.
1 "0x154F"	Identification number for the new Deltapilot S generation (FMB70).
127 "Auto. Id. Num."	Device adaptation mode (the device can communicate using a variety of identification numbers), see "Smart device management" (automatic smart device management).
128 "0x1503"	Compatibility mode for the old Deltapilot S generation (DB50, DB50L, DB51, DB52, DB53).

The "Automatic Identification Number Selection" (value = 127) for Profile 3.02 is described in the section on smart device management (automatic smart device management).

The choice of identification number affects the status and diagnostic messages ("Classic" or "Condensed"). "Old" identification numbers work with the "Classic" status and old diagnostic messages.

Depending on the configuration data of the user or the behavior selected in the COND.STATUS DIAG "Physical" block parameter, new identification numbers and the profile identification number work with either the "Condensed" or "Classic" status.

The identification number can only be changed if no cyclic communication is taking place with the device.

Cyclic data transmission and the corresponding identification number of the device remain the same until cyclic transmission is aborted and reestablished or the device is shut down.

When reestablishing cyclic data transmission the device uses the last identification number.

The choice of identification number also determines how many modules are assigned during cyclic communication. All blocks are internally instantiated in advance for all the devices but only the configured modules can be accessed depending on the entries in the device master data.

Table of the function blocks:

"IDENT NUMBER SEL." parameter	0 (Profile-specific)	128 (Old identification number)	127 (Auto. identification number)	1 (New identification number)
Cerabar S	3 blocks (PB,TB,AI)	...	Depends on the identification number automatically selected.	3 Blocks (PB, TB, AI)
	1 module (1xAI)	...		1 module (1x AI)

Table of the identification numbers:

Value for "IDENT NUMBER SEL."	Identification number	Selection text	Status	Diagnosis
0 (Profile-specific 3.x)	0x9700	0x9700	Classic status / Condensed status	New diagnostic messages
128 (Old identification number)	0x1503	0x1503	Classic status	Old diagnostic messages
127 (Adaptation mode)	0x9700/0x1503/ 0x154F	Auto. Identification number "Auto Id. Num."	Depends on ID numbers	Depends on ID numbers
1 (New identification number)	0x154F	0x154F	Classic status / Condensed status	New diagnostic messages

Smart device management (automatic smart device management)

Smart PA device management is performed by automatically adapting the device identification number. This makes it possible to replace old devices with new models without having to modify the PLC, allowing the transition from an installed device technology to a more sophisticated technology without interrupting the process.

With the "Automatic Identification Number Selection" option, the device behavior and rules (diagnostics, cyclic communication etc.) remain the same as those for a static identification number. The identification number is selected automatically depending on the recognized request frame -"Set Slave Parameter" or "Set Slave Address".

It is permitted to change the identification number in two specific device transition states, namely in the adaptation mode and only if the identification number is listed in the table above.

If the identification number is undefined and the selector is set to "Auto Id. Num.", following a "Get Slave Diagnose" frame the device returns an identification number diagnostic value which is compatible with the device. After every new "Get Slave Diagnose" frame, the device returns another identification number that is compatible with the device until the PLC sends a "Set Slave Address" or "Set Slave Parameter" frame with a known identification number.

6.3.5 Device identification and addressing

Note the following points:

- An address must be assigned to every PROFIBUS PA device. Only when the address is configured correctly will the device be recognized by the control system/master.
- Each address may only be assigned once in each PROFIBUS PA network.
- Valid device addresses are in the range from 0 to 125.
- The address 126 set at the factory can be used to check the function of the device and to connect to a PROFIBUS PA network already in operation. This address then has to be changed in order to integrate additional devices.
- All devices have the address 126 and software addressing on leaving the factory.
- The FieldCare operating program is delivered with the address 0 (default setting).

There are two ways of assigning the device address to Deltapilot S:

- Using a DP Class 2 master operating program, such as FieldCare or
- On site using the DIP switches

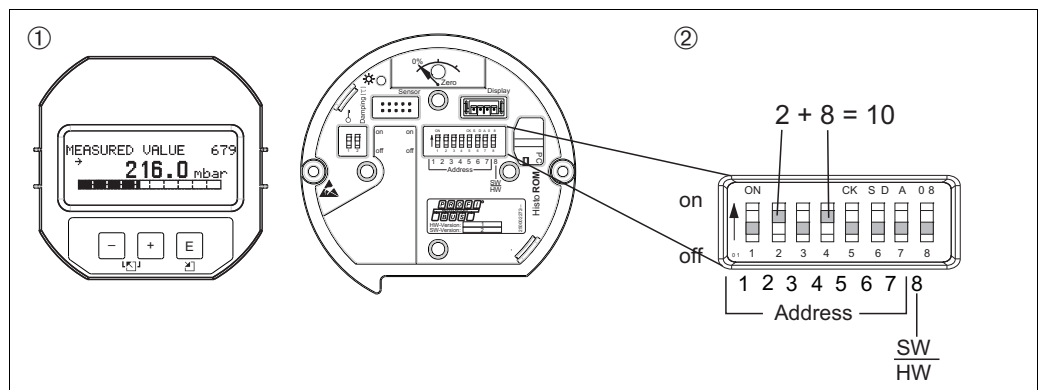

Fig. 14: Configuring the device address using the DIP switches

- 1 If necessary, remove onsite display (optional)
- 2 Set the hardware address via the DIP switches

Hardware addressing

Hardware addressing is configured as follows:

1. Set DIP switch 8 (SW/HW) to "Off".
2. Configure the address with DIP switches 1 to 7 (see graphic above).
3. You have to wait 10 seconds for a change in address to take effect. The device is restarted.

DIP-switch	1	2	3	4	5	6	7
Weighting in "On" position	1	2	4	8	16	32	64
Weighting in "Off" position	0	0	0	0	0	0	0

Software addressing

Software addressing is configured as follows:

1. Set DIP switch 8 (SW/HW) to "On" (factory setting).
2. The device is restarted.
3. The device reports its current address. Factory setting: 126
4. Configure the address via the configuration program.
See the following section for entering a new address using the ToF Tool.
For other operating programs, please refer to the relevant Operating Instructions.

Configuring the new address using the FieldCare. DIP switch 8 (SW/HW) is set to "On" (SW):

1. Using the "Device Operation" menu, select the "Connect" option. The "Open Connection Wizard" screen is displayed.
2. The device reports its current address. Factory setting: 126 ¹⁾
3. The device has to be disconnected from the bus before you can assign the device a new address. For this purpose, select the "Disconnect" option in the "Device Operation" menu.
4. Using the "Device Operation" "Device Functions" "Additional Functions" menu, select the "Set Device Station Address" option. The "PROFIdtm DPV1 (Set Device Station address)" screen is displayed.
5. Enter the new address and confirm with "Set".
6. The new address is assigned to the device.

1) The address 126 is not adjustable via the menu. After a reset (code 2712) the address is stored as a default address in the device.

6.3.6 System integration

Device Master Files (GSD)

The device is ready for system integration once commissioning has been effected via the Class 2 master (FieldCare). To integrate the field devices into the bus system, the PROFIBUS PA system requires a description of the device such as device identification, ID number, supported communication features, module structure (combination of cyclic input and output telegrams) and meaning of diagnosis bits.

These data are contained in a Device Master File (GSD file) which is placed at the disposal of the PROFIBUS DP master (e.g. PLC) while the communication system is being commissioned. Device bitmaps, which appear as icons in the network tree, can also be integrated.

The following versions of GSD are possible when using devices that support the "PA devices" profile:

- Manufacturer-specific GSD, ID number: 0x154F:
This GSD guarantees the unlimited functionality of the field device. All device-specific process parameters and functions are available.
- Manufacturer-specific GSD, ID number: 0x1503:
The device behaves like a Deltapilot S DB50, DB50L, DB51, DB52, DB53.
→ See Operating Instructions BA164F.
- Profile GSD:
As an alternative to the manufacturer-specific GSD, the PNO makes a general database file available with the name PA139700.gsd for devices with an Analog Input Block. This file supports the transmission of the primary value. The transmission of a 2ND CYCLIC VALUE or a display value is not supported. If a system has been configured with profile GSDs, it is possible to exchange devices that are supplied by various manufacturers.

The following Device Master Files (GSD) can be used with Deltapilot S:

Name of device	Comments	ID number (IDENT_NUMBER_SELECT) ¹⁾	GSD	Type file	Bit map
Deltapilot S PROFIBUS PA	Profile GSD	0x9700	PA139700.gsd		
	Device-specific GSD	0x154F ²⁾	EH3x154F.gsd EH02154F.gsd ³⁾		EH_154F_d.bmp/.dib EH_154F_n.bmp/.dib EH_154F_s.bmp/.dip
	Device-specific GSD. The device behaves like a Deltapilot S DB50, DB50L, DB51, DB52, DB53. → See Operating Instructions BA164F.	0x1503 ²⁾	EH3_1503.gsd EH3x1503.gsd	EH31503x.200	EH_1503_d.bmp/.dib EH_1503_n.bmp/.dib EH_1503_s.bmp/.dip

- 1) Select the corresponding ID number by means of the IDENT_NUMBER_SEL parameter menu path FieldCare: PROFILE VIEW → PHYSICAL BLOCK → PB PARAMETER menu path onsite display: GROUP SELECTION → OPERATING MENU → TRANSMITTER INFO → PA DATA.
- 2) Each device receives an ID number from the Profibus User Organization (PNO). The name of the Device Master File (GSD) is derived from this. For Endress+Hauser, this ID No. starts with the manufacturer ID "15xx".
- 3) The Profile 3.02 GSD file with the "Condensed Status" option is only compatible with SW 04.01.zz and must be imported individually into the configuration tool.

It is only possible to change the "IDENT NUMBER SEL" parameter if either the device is not integrated into the cyclic communication (not planned in the PLC) or the cyclic communication of the PLC is at Stop. If an attempt is nevertheless made to change the parameter via configuration software, e.g. FieldCare, the input is ignored.

The Device Master Files (GSD) for Endress+Hauser devices can be acquired in the following manner:

- Internet Endress+Hauser: <http://www.de.endress.com> → Download → Search for "GSD"
- Internet PNO: <http://www.profibus.com> (Products – Product Guide)
- On CD-ROM from Endress+Hauser, order number: 56003894

The Profile Device Master Files (GSD) of the PNO can be acquired in the following manner:

- Internet PNO: <http://www.profibus.com> (Products – Profile GSD Library)

Directory structure of GSD files from Endress+Hauser

For Endress+Hauser field devices with PROFIBUS PA interface, all the data which are needed for configuration are contained in a compressed file. After unpacking the file, the following structure is generated:

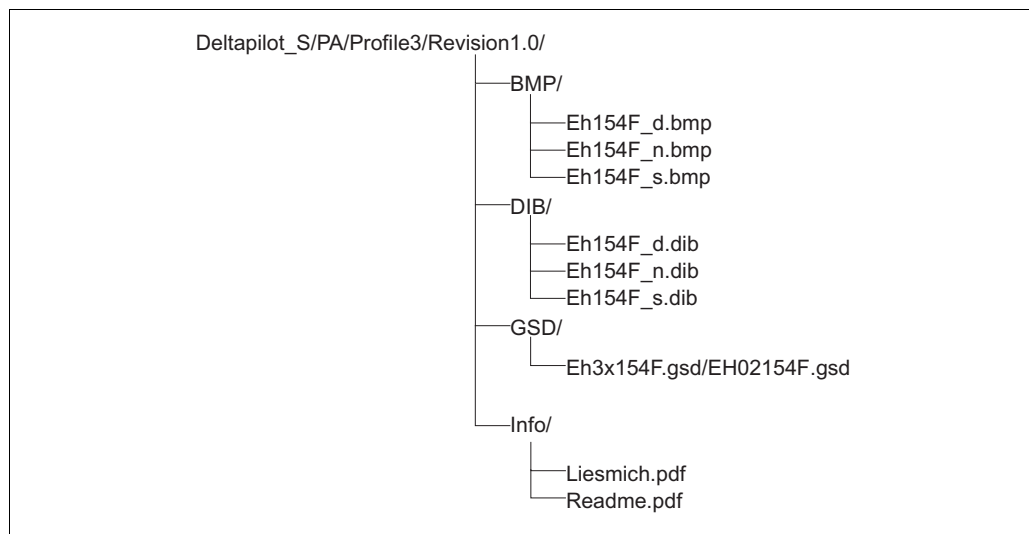

P01-xxxxxxxx-02-xx-xx-xx-003

Fig. 15: Directory structure of GSD 154F

- Revision x.x stands for the corresponding device version.
- Information relating to the implementation of the field transmitter and any dependencies in the device software can be found in the "Info" folder. Read this information carefully before configuring.
- Device-specific bitmaps can be found in the directories "BMP" and "DIB". The utilization of these will depend on the configuration software that is being used.

Working with Device Master Files (GSD)

The Device Master Files (GSD) must be integrated into a specific subdirectory of the PROFIBUS DP configuration software of the PLC used. Depending on the software that is being used, these files can be copied to the program-specific directory or can be read into the database using the import function within the configuration software.

Detailed information on the directories to which the Device Master Files (GSD) are to be saved is provided in the description of the configuration software used.

6.3.7 Cyclic data exchange

Deltapilot S block model

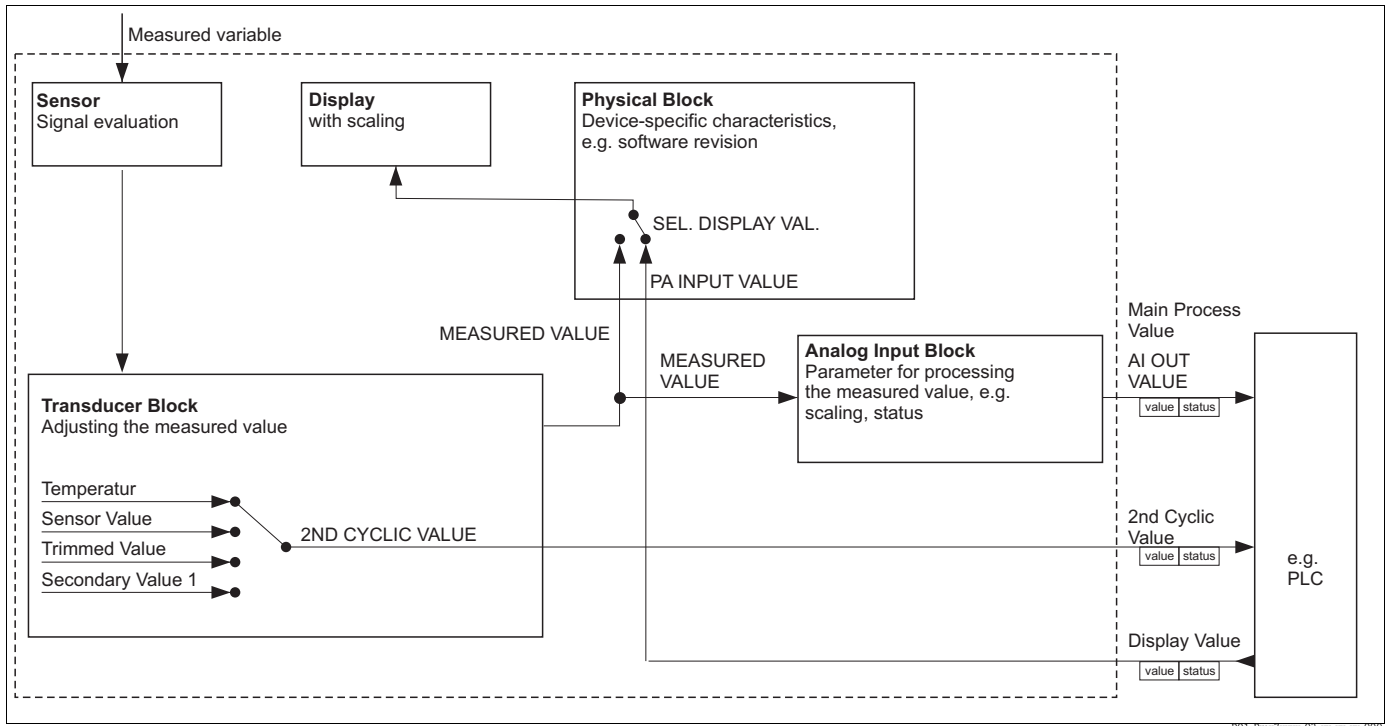

Fig. 16: The block model indicates what type of data can be transmitted between Deltapilot S and the Class 1 master (e.g. PLC) during cyclic data communication. Using the configuration software of your PLC, compile the cyclic data telegram with the aid of modules (→ see also "Modules for the cyclic data diagram" in this section). The parameters, written in CAPS, are parameters in the operating program (e.g. FieldCare) which you can use to make settings for the cyclic data telegram or to display values (→ see also "Description of parameters" in this section).

Deltapilot S function blocks

PROFIBUS uses predefined function blocks to describe the function blocks of a device and to specify uniform data access.

The following blocks are implemented in Deltapilot S:

- **Physical Block:**
The Physical Block contains device-specific features such as the device type, manufacturer, version etc. as well as functions such as write protection management and ID number switching
- **Transducer Block:**
The Transducer Block contains all the measuring and device-specific parameters of the device. In the Deltapilot S Transducer Block, the pressure measuring principle is illustrated for use as a pressure or level transmitter.
- **Analog Input Block (function block):**
The Analog Input Block contains the signal processing functions of the measured value such as scaling, special function calculations, simulation etc.

Description of parameters

Parameter name	Description
OUT VALUE	This parameter shows the digital output value of the Analog Input Block. Menu path FieldCare: PROFILE VIEW → ANALOG INPUT BLOCK → AI PARAMETER Menu path onsite display: GROUP SELECTION → OPERATING MENU → TRANSMITTER INFO → PA DATA
PA INPUT VALUE	This value is transmitted from the PLC to Deltapilot S. The PA INPUT VALUE can be displayed on the onsite display (→ see also this table, SEL. DISPLAY VAL.). Menu path FieldCare: PROFILE VIEW → PHYSICAL BLOCK → PB PARAMETER Menu path onsite display: GROUP SELECTION → OPERATING MENU → TRANSMITTER INFO → PA DATA
SEL. DISPLAY VAL.	Use this parameter to specify whether the primary value or a value of the PLC is displayed on the onsite display. Menu path FieldCare: MANUFACTURER VIEW → OPERATING MENU → DISPLAY or PROFILE VIEW → PHYSICAL BLOCK → PB PARAMETER → PROFIBUS PA CONF Menu path onsite display: GROUP SELECTION → OPERATING MENU → TRANSMITTER INFO → PA DATA Options: <ul style="list-style-type: none"> ■ Primary value (PV): the primary value is displayed on the onsite display. ■ Input value: a value from the PLC is displayed on the onsite display (→ see this table, PA INPUT VALUE). Example for the "Input value" option: <ul style="list-style-type: none"> ■ Two Deltapilot S transmitters measure the pressure drop across a filter. The differential pressure is registered in the PLC. Use the "Input value" option to assign this calculated value to the onsite display. Factory setting: <ul style="list-style-type: none"> ■ Primary value (PV)
2ND CYCLIC VALUE	You can use this parameter to specify which value should be transmitted via the bus as the 2ND CYCLIC VALUE. Menu path FieldCare: PROFILE VIEW → PHYSICAL BLOCK → PB PARAMETER → PROFIBUS PA CONF Menu path onsite display: GROUP SELECTION → OPERATING MENU → TRANSMITTER INFO → PA DATA Options: <ul style="list-style-type: none"> ■ Temperature ■ Sensor value: corresponds to the SENSOR PRESSURE parameter ■ Trimmed value: corresponds to the CORRECTED PRESS. parameter ■ Secondary value 1: corresponds to the PRESSURE parameter The SENSOR PRESSURE, CORRECTED PRESSURE and PRESSURE parameters are displayed in the PROCESS VALUES menu (menu path: MANUFACTURER VIEW → OPERATING MENU → PROCESSINFO → PROCESS VALUES). The TEMPERATURE parameter is displayed in the TB PARAMETER menu (menu path: PROFILE VIEW → TRANSDUCER BLOCK → TB PARAMETER) Factory setting: <ul style="list-style-type: none"> ■ Temperature

Modules for the cyclic data diagram

Deltapilot S makes the following modules available for the cyclic data diagram:

- Main process value
Depending on the operating mode selected, a pressure or level value is transmitted here.
- 2ND CYCLIC VALUE
Depending on the option selected, a temperature, the sensor value, trimmed value or secondary value 1 is transmitted here.
- Display value
This is any value that is transmitted from the PLC to Deltapilot S. This value can also be displayed on the onsite display.
- FREE PLACE
Select this empty module if a value should not be used in the data telegram.

Structure of the output data PLC → Deltapilot S

With the Data_Exchange service, a PLC can read output data from Deltapilot S in the call telegram. The cyclic data telegram has the following structure:

Index output data	Data	Access	Data format/comments
0, 1, 2, 3	Display value	Write	32 bit floating point number (IEEE 754)
4	Status code	Write	→ See "Status codesStatus codes"

Structure of the input data Deltapilot S → PLC

With the Data_Exchange service, a PLC can read input data from Deltapilot S in the response telegram. The cyclic data telegram has the following structure:

Index input data	Data	Access	Data format/comments
0, 1, 2, 3	Main process value: pressure or level	Read	32 bit floating point number (IEEE 754)
4	Status code for main process value	Read	→ See "Status codesStatus codes"
5, 6, 7, 8	2ND CYCLIC VALUE: temperature, sensor value, trimmed value or secondary value 1	Read	32 bit floating point number (IEEE 754)
9	Status code for 2ND CYCLIC VALUE	Read	→ See "Status codesStatus codes"

Status codes

Deltapilot S supports the "Condensed status" function as defined in the PNO specification. However, the "Classic" status is also supported to ensure compatibility with older devices in the S series and due to the profile-specific identification number ("0x9700").

If the profile number and new identification number are selected, the status type can be set via the "COND.STATUS DIAG" parameter.

The "Condensed" and/or "Classic" status and their current active states are displayed by the "Physical Block" in the "Feature" parameter. The measuring device supports the following status codes for the output value parameters of the Analog Input Block:

Classic status:

Status code	Device status	Meaning	Output value (OUT Value) (Analog Input)	2ND CYCLIC VALUE
0000 0000	Bad	Not specific	X ¹⁾	X
0000 0100	Bad	Configuration error (e.g. adjustment not performed correctly)	X ¹⁾	X
0000 1100	Bad	Device error	X ¹⁾	X
0001 0000	Bad	Sensor error	X ¹⁾	X
0001 1100	Bad	Out of service (target mode)	X	X
0100 0000	Uncertain	Not-specific	X	X
0100 0100	Uncertain	Last valid value (failure behavior = 1)	X	X
0100 1000	Uncertain	Substitute value (failure behavior = 0)	X	X
0100 1100	Uncertain	Initial value (failure behavior = 1)	X	X
0101 1100	Uncertain	Configuration error (e.g. linearization table not monotonic increasing)	X	X
0101 0011	Uncertain	Sensor conversion not accurate - constant	X	X
0101 0010	Uncertain	Sensor conversion - limit value exceeded	X	X
0101 0001	Uncertain	Sensor conversion - limit value undershot	X	X
0110 0000	Uncertain	Simulation value	X	X
1000 0000	GOOD	Good	X	X
1000 1000	GOOD	Warning limit	X	X
1000 1001	GOOD	Warning limit - limit value exceeded	X	X
1000 1010	GOOD	Warning limit - limit value undershot	X	X
1000 1100	GOOD	Alarm limit	X	X
1000 1101	GOOD	Alarm limit - limit value exceeded	X	X

Status code	Device status	Meaning	Output value (OUT Value) (Analog Input)	2ND CYCLIC VALUE
1000 1110	GOOD	Alarm limit - limit value undershot	X	X

1) Only if the analog input failure behavior = 2 ("Status Bad")

Condensed status:

The main reason for implementing the "Condensed" status mode in the Profibus PA Profile 3.02 is to clarify the diagnostic events resulting from use in the PCS/DCS and in the operating station.

Furthermore, this functionality also implements the requirements of NE 107.

The following "Condensed" status codes are configured via the device.

Status code ¹⁾	Device status	Meaning	Output value (OUT Value) (Analog Input 1)	2ND CYCLIC VALUE
0010 01xx	Bad ²⁾	Maintenance alarm, advanced diagnostics present	X ³⁾	X
0010 10xx	Bad ²⁾	Process error, no maintenance required	X ³⁾	X
0011 11xx	Bad ²⁾	Function check / local override	X ³⁾	X
0010 0011	Bad ²⁾	Switch off	X	X
0111 1011	Uncertain	Process error, no maintenance required - limit value constant	X	X
0111 1010	Uncertain	Process error, no maintenance required - limit value exceeded	X	X
0111 1001	Uncertain	Process error, no maintenance required - limit value undershot	X	X
0111 1000	Uncertain	Process error, no maintenance required	X	X
0110 10xx	Uncertain	Maintenance required	X	X
0100 1011	Uncertain	Substitute value	X	
0100 1111	Uncertain	Initial value	X	
0111 0011	Uncertain	Simulated value, start	X	X
0111 0100	Uncertain	Simulated value, end	X	
1000 0000	GOOD	Good	X	X
1011 1100	GOOD	Function check	X	X
1010 01xx	GOOD	Maintenance required	X	X
1010 10xx	GOOD	Maintenance required	X	X

1) Variable x: 0 or 1

2) zzz Page → Kap. 9.2.1

3) Only if the analog input failure behavior = 2 ("Status Bad")

6.3.8 Acyclic data exchange

Acyclic data exchange is used:

- To transmit commissioning or maintenance parameters
- To display measured variables not contained in the cyclic data diagram.

Using acyclic data exchange, device parameters can be modified even when the device is involved in cyclic data exchange with a PLC.

There are two types of acyclic data exchange:

- Acyclic communication via the C2 channel (MS2)
- Acyclic communication via the C1 channel (MS1)

Acyclic communication via the C2 channel (MS2)

When communicating via the C2 channel, a master opens a communication channel by means of a service access point (SAP) to access the device. A master that supports acyclic communication via the C2 channel is called a Class 2 master. FieldCare is an example of a Class 2 master.

All the device parameters have to be made known to the master before data can be exchanged via PROFIBUS.

For this, you have the following options:

- A configuration program in the master that accesses the parameters via the slot and index addresses (e.g. FieldCare)
- A software component (DTM: Device Type Manager)
- The DTM is available on the FieldCare CD.
- The number of Class 2 masters that can simultaneously communicate with a device is restricted to the number of SAPs available for this communication. Deltapilot S supports MS2 communication with two SAPs. Here, you must make certain that they do not both attempt to write-access the same data, since otherwise the data consistency cannot be guaranteed.
- Using the C2 channel for acyclic data exchange increases the cycle times of the bus system. This should be taken into account when programming the control system.

Acyclic communication via the C1 channel (MS1)

With acyclic communication via the C1 channel, a master that is already communicating cyclically with the device also opens an acyclic communication channel via SAP 0x33 (special SAP for MS1). The master can then acyclically read or write the parameters like a Class 2 master via slot and index addresses.

Deltapilot S supports MS1 communication with one SAP.

NOTICE

Shortening the lifetime of the device!

Parameters written acyclically are written to memory modules (EEPROM, Flash, etc.). These are resistant to voltage. The memory modules are only designed for a limited number of writes which is not even remotely reached in normal operation without MS1 (during configuration). This figure can be quickly exceeded as a result of incorrect programming and thus the operating time of a device can be drastically reduced.

- ▶ In the application program, avoid constantly writing parameters, e.g. for every cycle of the program.

6.3.9 Slot/index tables

The device parameters are listed in the following tables. You can access the parameters by means of the slot and index number. The individual blocks each contain standard parameters, block parameters and manufacturer-specific parameters. If you use the FieldCare as an operating program, input screens are available as a user interface.

General explanatory remarks

Object type

- Record: contains data structure (DS)
- Array: group of a certain data type
- Simple: contains individual data types such as Float

Data type

- DS: data structure, contains data types such as Unsigned8, Octet String etc.
- Float: IEEE 754 format
- Integer:
 - Integer8: value range = -128...127
 - Integer16: value range = -32768...32768
 - Integer32: value range = $-2^{31}...2^{31}$
- Octet String: binary coded
- Visible String: ASCII coded
- Unsigned:
 - Unsigned8: value range = 0...255
 - Unsigned16: value range = 0...65535
 - Unsigned32: value range = 0...4294967295

Storage Class

- Cst: constant parameter
- D: dynamic parameter
- N: nonvolatile parameter
- S: static parameter

Device management

Parameter	Slot	Index	Object type	Data type	Size (byte)	Storage Class	Read	Write
Directory object header	1	0	Array	Unsigned16	12	Cst	x	
Composite list directory entries	1	1	Array	Unsigned16	24	Cst	x	
GAP directory continuous	1	2 - 8						
GAP reserved	1	9 - 15						

Physical Block

Parameter	Slot	Index	Object type	Data type	Size (byte)	Storage Class	Read	Write
Physical Block standard parameters								
BLOCK OBJECT	0	16	Record	DS-32	20	Cst	x	
STATIC REVISION NO.	0	17	Simple	Unsigned16	2	N	x	
TAG_DESC	0	18	Simple	Visible String	32	S	x	x
STRATEGY	0	19	Simple	Unsigned16	2	S	x	x
ALERT KEY	0	20	Simple	Unsigned8	1	S	x	x
TARGET MODE	0	21	Simple	Unsigned8	1	S	x	x
MODE BLK	0	22	Record	DS-37	3	D	x	
ALARM SUM	0	23	Record	DS-42	8	D	x	
Physical Block parameters								
SOFTWARE VERSION	0	24	Simple	Visible String	16	Cst	x	
HARDWARE REV.	0	25	Simple	Visible String	16	Cst	x	
MANUFACTOR ID	0	26	Simple	Unsigned16	2	Cst	x	
DEVICE NAME STR.	0	27	Simple	Visible String	16	Cst	x	
DEVICE SERIAL No.	0	28	Simple	Visible String	16	Cst	x	
DIAGNOSIS	0	29	Simple	Octet String	4	D	x	
DIAGNOSIS EXTENSION	0	30	Simple	Octet String	6	D	x	
DEVICE CERTIFICATION	0	33	Simple	Visible String	32	Cst	x	
INSERT PIN No	0	34	Simple	Unsigned16	2	N	x	x
ADDITIONAL INFO	0	36	Simple	Visible String	32	S	x	x
USER DESCRIPTION	0	37	Simple	Visible String	32	S	x	x
INSTALLATION DATE	0	38	Simple	Visible String	16	S	x	x
IDENT NUMBER SEL	0	40	Simple	Unsigned8	1	S	x	x
DIP STATUS	0	41	Simple	Unsigned8	1	D	x	
FEATURE	0	42	Record	DS-68	8	N	x	
COND.STATUS DIAG	0	43	Simple	Unsigned8	1	S	x	x
Physical Block, Endress+Hauser parameters								
ALARM STATUS	0	54	Simple	Unsigned16	2	D	x	
LAST DIAG. CODE	0	55	Simple	Unsigned16	2	D	x	
UP_DOWN_FEAT	0	56	Simple	Unsigned8	1	Cst	x	
UP/DOWNLOAD CTRL	0	57	Simple	Unsigned8	1	D		x
UP/DOWN PARAM	0	58	Simple	OctetString	20	D	x	x
BUS.ADDRESS	0	59	Simple	Unsigned8	1	D	x	
SET_UNIT_TO_BUS	0	61	Simple	Unsigned8	1	S	x	x
PA INPUT VALUE	0	62	Record	E+H specific	6	D	x	x
SEL_DISPLAY VAL.	0	63	Simple	Unsigned8	1	S	x	x
PROFILE_REV	0	64	Simple	Visible String	32	Cst	x	
RESET ALL ALARMS	0	65	Simple	Unsigned8	1	S	x	x
IDENT_NUMBER	0	66	Simple	Unsigned16	2	D	x	
2ND CYCLIC VALUE	0	68	Simple	Unsigned8	1	S	x	
DEVICE DESIGN.	0	69	Simple	Visible String	32	S	x	
CONFIG RECORDER	0	74	Simple	Unsigned16	2	D	x	
OPERATING HOURS	0	75	Simple	Unsigned32	4	D	x	
SIM. ERROR NO.	0	76	Simple	Unsigned16	2	D	x	x
SIM. MESSAGES	0	77	Simple	Unsigned8	1	D	x	x
LANGUAGE	0	78	Simple	Unsigned8	1	N	x	x
DISPLAY CONTRAST	0	79	Simple	Unsigned8	1	S	x	x
MENU DESCRIPTOR	0	80	Simple	Unsigned8	1	N	x	x
MAIN DATA FORMAT	0	81	Simple	Unsigned8	1	D	x	x
ALTERNATE DATA	0	82	Simple	Unsigned8	1	N	x	x
UNIT TEXT	0	83	Simple	Visible String	8	S	x	x
USER DESCRIPTION	0	84	Simple	Visible String	32	S	x	x
ACK_ALARM MODE	0	85	Simple	Unsigned8	1	S	x	x
ACK_ALARM	0	86	Simple	Unsigned8	1	D	x	x
SELECT_ALARM TYPE	0	87	Simple	Unsigned8	1	S	x	x
ERROR NO.	0	88	Simple	Unsigned16	2	D	x	x
ALARM DELAY	0	89	Simple	Float	4	S	x	x
ALARM DISPL. TIME	0	90	Simple	Float	4	S	x	x
3RD CYCLIC VALUE	0	93	Simple	Unsigned8	1	S	x	x
HistoROM AVAIL.	0	94	Simple	Unsigned8	1	D	x	
HIST.SAVING CYCL	0	95	Simple	Unsigned8	1	S	x	x
HistoROM CONTROL	0	96	Simple	Unsigned8	1	S	x	x
ELECTR. SERIAL NO.	0	97	Simple	Visible String	32	Cst	x	

Parameter	Slot	Index	Object type	Data type	Size (byte)	Storage Class	Read	Write
PCB TEMPERATURE	0	98	Simple	Float	4	D	x	
Allowed Min. TEMP	0	99	Simple	Float	4	Cst	x	
Allowed Max. TEMP	0	100	Simple	Float	4	Cst	x	
PCB COUNT: T > Tmax	0	101	Simple	Unsigned16	2	D	x	
PCB MAX. TEMP.	0	102	Simple	Float	4	D	x	
PCB COUNT: T < Tmin	0	103	Simple	Unsigned16	4	D	x	
PCB MIN. TEMP.	0	104	Simple	Float	4	D	x	
MAIN DATA FORMAT	0	106	Simple	Unsigned8	1	D	x	
DOWNLOAD FUNCT.	0	107	Simple	Unsigned8	1	N	x	x
STATUS LOCKING	0	108	Simple	Unsigned8	1	S	x	x
DEVICE STATUS	0	109	Simple	Unsigned8	1	S	x	
STATUS SELECT EVENT 727	0	110	Simple	Unsigned8	1	S	x	x
STATUS SELECT EVENT 115	0	111	Simple	Unsigned8	1	S	x	x
STATUS SELECT EVENT 120	0	112	Simple	Unsigned8	1	S	x	x
STATUS SELECT EVENT 731	0	113	Simple	Unsigned8	1	S	x	x
STATUS SELECT EVENT 730	0	114	Simple	Unsigned8	1	S	x	x
STATUS SELECT EVENT 733	0	115	Simple	Unsigned8	1	S	x	x
STATUS SELECT EVENT 732	0	116	Simple	Unsigned8	1	S	x	x
STATUS SELECT EVENT 726	0	117	Simple	Unsigned8	1	S	x	x
STATUS SELECT EVENT 715	0	118	Simple	Unsigned8	1	S	x	x
STATUS SELECT EVENT 720	0	119	Simple	Unsigned8	1	S	x	x
STATUS SELECT EVENT 717	0	120	Simple	Unsigned8	1	S	x	x
STATUS SELECT EVENT 718	0	121	Simple	Unsigned8	1	S	x	x
STATUS SELECT EVENT 740	0	122	Simple	Unsigned8	1	S	x	x
STATUS SELECT EVENT 716	0	123	Simple	Unsigned8	1	S	x	x
STATUS SELECT	0	124	Record	14xUnsigned8	14	S	x	x
SWITCH_STATUS_LIST	0	125	Record	2x Unsigned8	2	D	x	
SENSOR SER. No.	0	126	Simple	Visible String	16	S	x	

Analog Input Block

Parameter	Slot	Index	Object type	Data type	Size (byte)	Storage Class	Read	Write
Analog Input Block standard parameters								
BLOCK OBJECT	1	16	Record	DS-32	20	Cst	x	
STATIC REVISION NO.	1	17	Simple	Unsigned16	2	N	x	
TAG_DESC	1	18	Simple	Visible String	32	S	x	x
STRATEGY	1	19	Simple	Unsigned16	2	S	x	x
ALERT KEY	1	20	Simple	Unsigned8	1	S	x	x
TARGET MODE	1	21	Simple	Unsigned8	1	S	x	x
MODE BLK	1	22	Record	DS-37	3	D	x	
ALARM SUM	1	23	Record	DS-42	8	D	x	
Analog Input Block parameters								
BATCH	1	24	Record	DS-67	10	S	x	x
OUT	1	26	Record	DS-33	5	D	x	x ¹⁾
PV SCALE	1	27	Array	Float	8	S	x	x
OUT SCALE	1	28	Record	DS-36	11	S	x	x
LIN TYPE	1	29	Simple	Unsigned8	1	S	x	x
CHANNEL	1	30	Simple	Unsigned16	2	S	x	x
FILTER TIME CONST	1	32	Simple	Float	4	S	x	x
FAIL SAFE MODE	1	33	Simple	Unsigned8	1	S	x	x
FAIL SAFE DEFAULT VALUE	1	34	Simple	Float	4	S	x	x
LIMIT HYSTERESIS	1	35	Simple	Float	4	S	x	x
UPPER LIMIT ALARM	1	37	Simple	Float	4	S	x	x
UPPER LIMIT WARNING	1	39	Simple	Float	4	S	x	x
LOWER LIMIT WARNING	1	41	Simple	Float	4	S	x	x
LOWER LIMIT ALARM	1	43	Simple	Float	4	S	x	x
HI_HI_ALM	1	46	Record	DS-39	16	D	x	
HI_ALM	1	47	Record	DS-39	16	D	x	
LO_ALM	1	48	Record	DS-39	16	D	x	
LO_LO_ALARM	1	49	Record	DS-39	16	D	x	
SIMULATE	1	50	Record	DS-50	6	S	x	x
VIEW_1_FB	1	61	Simple	Octet String	18	D	x	

1) If MODE BLK Actual = Manual (MAN)

Transducer Block

Parameter	Slot	Index	Object type	Data type	Size (byte)	Storage Class	Read	Write
Transducer Block standard parameters								
BLOCK OBJECT	2	16	Record	DS-32	20	Cst	x	
STATIC REVISION NO.	2	17	Simple	Unsigned16	2	N	x	
TAG_DESC	2	18	Simple	Visible String	32	S	x	x
STRATEGY	2	19	Simple	Unsigned16	2	S	x	x
ALERT KEY	2	20	Simple	Unsigned8	1	S	x	x
TARGET MODE	2	21	Simple	Unsigned8	1	S	x	x
MODE BLK	2	22	Record	DS-37	3	D	x	
ALARM SUM	2	23	Record	DS-42	8	D	x	
SENSOR PRESSURE	2	24	Simple	Float	4	D	x	
PRESS.SENS HILIM	2	25	Simple	Float	4	N	x	
PRESS.SENS LOLIM	2	26	Simple	Float	4	N	x	
HIGH SENSOR TRIM	2	27	Simple	Float	4	S	x	x
LOW SENSOR TRIM	2	28	Simple	Float	4	S	x	x
MINIMUM SPAN	2	29	Simple	Float	4	N	x	
PRESS. ENG. UNIT	2	30	Simple	Unsigned16	2	S	x	
TRIMMED_VALUE (Corrected Press.)	2	31	Record	DS-33	5	D	x	
SENSOR MEAS.TYPE	2	32	Simple	Unsigned16	2	N	x	
SENSOR SER. No.	2	33	Simple	Unsigned32	4	N	x	
PRIMARY VALUE (Measured Value)	2	34	Record	DS-33	5	D	x	
PRIM_VALUE_UNIT	2	35	Simple	Unsigned16	2	S	x	x
PRIM_VALUE_TYPE	2	36	Simple	Unsigned16	2	S	x	x
MAT. MEMBRANE	2	37	Simple	Unsigned16	2	S	x	
FILLING FLUID	2	38	Simple	Unsigned16	2	S	x	
SEAL TYPE	2	40	Simple	Unsigned16	2	S	x	x
PROC.CONN.TYPE	2	41	Simple	Unsigned16	2	S	x	x
MAT.PROC.CONN. +	2	42	Simple	Unsigned16	2	S	x	x
TB TEMPERATURE (Sensor Temp.)	2	43	Record	DS-33	5	D	x	
TEMP. ENG UNIT	2	44	Simple	Unsigned16	2	S	x	x
SEC_VALUE_1 (PRESSURE)	2	45	Record	DS-33	5	D	x	
SEC_VALUE1_UNIT	2	46	Simple	Unsigned16	2	S	x	x
SEC_VALUE_2	2	47	Record	DS-33	5	D	x	
SEC_VALUE2_UNIT	2	48	Simple	Unsigned16	2	S	x	x
LIN_TYP	2	49	Simple	Unsigned8	1	S	x	x
SCALE_IN	2	50	Array	Float	8	S	x	x
SCALE_OUT	2	51	Array	Float	8	S	x	x
LOW_FLOW_CUT_OFF	2	52	Simple	Float	4	S	x	x
FLOW_LIN_SQUARE	2	53	Simple	Float	4	S	x	x
TAB_ACTUAL_NUMB	2	54	Simple	Unsigned8	1	N	x	
LINE-NUMB	2	55	Simple	Unsigned8	1	D	x	x
TAB_MAX_NR	2	56	Simple	Unsigned8	1	N	x	
TAB_MIN_NR	2	57	Simple	Unsigned8	1	N	x	
TAB_OP_CODE	2	58	Simple	Unsigned8	1	D	x	x
TAB_STATE	2	59	Simple	Unsigned8	1	D	x	
TAB_XY_VALUE	2	60	Array	Float	8	D	x	x
MAX. MEAS. PRESS.	2	61	Simple	Float	4	N	x	x ¹⁾
MIN. MEAS. PRESS.	2	62	Simple	Float	4	N	x	x ¹⁾
MAX. MEAS.TEMP.	2	63	Simple	Float	4	N	x	x ¹⁾
MIN. MEAS. TEMP.	2	64	Simple	Float	4	N	x	x ¹⁾
EMPTY CALIB.	2	75	Simple	Float	4	S	x	x
FULL CALIB.	2	76	Simple	Float	4	S	x	x
TANK CONTENT UNIT	2	77	Simple	Unsigned16	2	N	x	
UNIT FLOW	2	78	Simple	Unsigned16	2	N	x	x
DAMPING VALUE	2	79	Simple	Float	4	S	x	x
MAX FLOW	2	80	Simple	Float	4	S	x	x
MAX PRESS. FLOW	2	81	Simple	Float	4	S	x	x
PminALARM WINDOW	2	82	Simple	Float	4	S	x	x
PmaxALARM WINDOW	2	83	Simple	Float	4	S	x	x
TminALARM WINDOW	2	84	Simple	Float	4	S	x	x
TmaxALARM WINDOW	2	85	Simple	Float	4	S	x	x
SIMULATED VALUE	2	86	Simple	Float	4	D	x	x
SIMULATION MODE	2	87	Simple	Unsigned8	1	D	x	x
COUNTER P>Pmin	2	88	Simple	Unsigned16	2	D	x	
COUNTER P<Pmax	2	89	Simple	Unsigned16	2	D	x	
COUNTER T>Tmax	2	90	Simple	Unsigned16	2	D	x	

Parameter	Slot	Index	Object type	Data type	Size (byte)	Storage Class	Read	Write
COUNTER T<Tmin	2	91	Simple	Unsigned16	2	D	x	
MEAS. VAL. TREND	2	92	Simple	Unsigned8	1	D	x	
TOTALIZER 1	2	93	Simple	Visible String	8	D	x	
TOTAL. 1 OVERFLOW	2	94	Simple	Visible String	8	D	x	
TOTALIZER 2	2	95	Simple	Visible String	8	D	x	
TOTAL. 2 OVERFLOW	2	96	Simple	Visible String	8	D	x	
TEMP Abs RANGE	2	97	Simple	Float	4	Cst	x	
Tmin SENSOR	2	98	Simple	Float	4	Cst	x	
Tmax SENSOR	2	99	Simple	Float	4	Cst	x	
SENSOR H/WARE REV.	2	100	Simple	Unsigned8	1	Cst	x	
Pmax PROC. CONN.	2	101	Simple	Float	4	S	x	x
TOTAL. 1 ENG. UNIT	2	102	Simple	Unsigned16	2	S	x	x
TOTAL. 2 ENG. UNIT	2	103	Simple	Unsigned16	2	S	x	x
FACT.U.U.TOTAL.1	2	104	Simple	Float	4	S	x	x
FACT.U.U.TOTAL.2	2	105	Simple	Float	4	S	x	x
TOT. 1 USER UNIT	2	106	Simple	Visible String	8	S	x	x
TOT. 2 USER UNIT	2	107	Simple	Visible String	8	S	x	x
NEG. FLOW TOT. 1	2	108	Simple	Unsigned8	1	S	x	x
NEG. FLOW TOT. 2	2	109	Simple	Unsigned8	1	S	x	x
RESET TOTALISER1	2	110	Simple	Unsigned8	1	S	x	x
FLOW-MEAS. TYPE	2	111	Simple	Unsigned8	1	S	x	x
CUSTOMER UNIT F	2	112	Simple	Visible String	8	S	x	x
CUST.UNIT FACT.F	2	113	Simple	Float	4	S	x	x
CUSTOMER UNIT P	2	114	Simple	Visible String	8	S	x	x
CUST.UNIT FACT.P	2	115	Simple	Float	4	S	x	x
POS.ZERO ADJUST	2	116	Simple	Unsigned8	1	D	x	x
POS. INPUT VALUE	2	117	Simple	Float	4	S	x	x
CALIB. OFFSET	2	118	Simple	Float	4	S	x	x
TANK DESCRIPTION	2	119	Simple	Visible String	32	S	x	x
LIN. EDIT MODE	2	120	Simple	Unsigned8	1	N	x	x
CALIBRATION MODE	2	121	Simple	Unsigned8	1	S	x	x
ADJUST DENSITY	2	122	Simple	Float	4	N	x	
LEVEL UNIT TXT	2	123	Simple	Visible String	8	S	x	x
CUST.UNIT FACT.L	2	124	Simple	Float	4	S	x	x
CUST. UNIT CONT.	2	125	Simple	Visible String	8	S	x	x
FACTOR TANK CONT.	2	126	Simple	Float	4	S	x	x
DENSITY UNIT	2	127	Simple	Unsigned16	2	S	x	x
ADJUST DENSITY	2	128	Simple	Float	4	S	x	x
TANK VOLUME	2	129	Simple	Float	4	S	x	x
TANK HEIGHT	2	130	Simple	Float	4	S	x	x
100% POINT	2	131	Simple	Float	4	S	x	x
ZERO POSITION	2	132	Simple	Float	4	S	x	x
LEVEL MIN.	2	133	Simple	Float	4	S	x	x
LEVEL MAX.	2	134	Simple	Float	4	S	x	x
PROCESS DENSITY	2	135	Simple	Float	4	S	x	x
MAX TURNDOWN	2	136	Simple	Float	4	S	x	
SENSOR CHANGES	2	137	Simple	Unsigned16	2	S	x	
P PEAKHOLD.STEP	2	138	Simple	Float	4	S	x	
T PEAKHOLD.STEP	2	139	Simple	Float	4	S	x	
ACC. OF GRAVITY	2	140	Simple	Float	4	S	x	
CREEP FLOW HYST.	2	141	Simple	Float	4	S	x	
LEVEL BEFORE LIN.	2	142	Simple	Float	4	D	x	
ENG. UNIT LEVEL	2	145	Simple	Unsigned16	2	S	x	x
UNIT VOLUME	2	146	Simple	Unsigned16	2	S	x	x
CUSTOMER UNIT V	2	147	Simple	Visible String	8	S	x	x
CUST.UNIT FACT.V	2	148	Simple	Float	4	S	x	x
SET.L.FL.CUT-OFF	2	149	Simple	Float	4	S	x	x
MAT.PROC.CONN. -	2	150	Simple	Unsigned16	2	S	x	x
TANK CONTENT	2	151	Simple	Float	4	D	x	
SUPPRESSED FLOW	2	152	Simple	Float	4	D	x	
RESET PEAKHOLD	2	153	Simple	Unsigned8	1	D	x	x
MEASURING MODE	2	154	Simple	Unsigned8	1	S	x	x
UNIT FLOW	2	155	Simple	Unsigned16	2	S	x	x
TOTALIZER 1 UNIT (Volume p. cond.)	2	156	Simple	Unsigned16	2	S	x	x
TOTALIZER 2 UNIT (Volume p. cond.)	2	157	Simple	Unsigned16	2	S	x	x
LOW FLOW CUT-OFF	2	158	Simple	Unsigned8	1	S	x	x
LO TRIM MEASURED	2	159	Simple	Float	4	N	x	
HI TRIM MEASURED	2	160	Simple	Float	4	N	x	

Parameter	Slot	Index	Object type	Data type	Size (byte)	Storage Class	Read	Write
PERCENT UNIT	2	161	Simple	Unsigned16	2	Cst	x	x
X-VAL:	2	162	Simple	Float	4	N	x	x
Y-VAL:	2	163	Simple	Float	4	N	x	x
MASS FLOW UNIT	2	164	Simple	Unsigned16	2	S	x	x
SIM. FLOW VALUE	2	165	Simple	Float	4	D	x	x
STD. FLOW UNIT	2	166	Simple	Unsigned16	2	S	x	x
NORM FLOW UNIT	2	167	Simple	Unsigned16	2	S	x	x
TOTALIZER 1 UNIT (Mass p. cond.)	2	168	Simple	Unsigned16	2	S	x	x
TOTALIZER 2 UNIT (Mass p. cond.)	2	169	Simple	Unsigned16	2	S	x	x
TOTALIZER 1 UNIT (Gas. std. conditions)	2	170	Simple	Unsigned16	2	S	x	x
TOTALIZER 2 UNIT (Gas. std. conditions)	2	171	Simple	Unsigned16	2	S	x	x
TOTALIZER 1 UNIT – (Gas. norm conditions)	2	172	Simple	Unsigned16	2	S	x	x
TOTALIZER 2 UNIT – (Gas. norm conditions)	2	173	Simple	Unsigned16	2	S	x	x
MASS UNIT	2	174	Simple	Unsigned16	2	S	x	x
CUST.UNIT FACT.M	2	175	Simple	Float	4	S	x	x
CUSTOMER UNIT M	2	176	Simple	Visible String	8	S	x	x
HEIGHT UNIT	2	177	Simple	Unsigned16	2	S	x	x
CUST.UNIT FACT.H	2	178	Simple	Float	4	S	x	x
CUSTOMER UNIT H	2	179	Simple	Visible String	8	S	x	x
EMPTY PRESSURE	2	180	Simple	Float	4	N	x	
FULL PRESSURE	2	181	Simple	Float	4	N	x	
SIM. LEVEL	2	182	Simple	Float	4	D	x	x
SIM. TANK CONT.	2	183	Simple	Float	4	D	x	x
LEVEL MODE	2	184	Simple	Float	4	S	x	x
ACTIV LIN.TAB.X	2	185	Simple	Float	4	N	x	
X-VAL (semi-autom.):	2	186	Simple	Float	4	D	x	
TANK CONTENT MAX.	2	188	Simple	Float	4	S	x	x
TANK CONTENT MIN.	2	189	Simple	Float	4	S	x	x
HYDR. PRESS MAX.	2	190	Simple	Float	4	S	x	x
TAB. ACTIVATE	2	191	Simple	Unsigned8	1	D	x	
TABLE EDITOR	2	192	Simple	Unsigned8	1	N	x	x
ACTIVE LIN. TAB. Y	2	193	Simple	Float	4	N	x	x
HYDR. PRESS MIN.	2	194	Simple	Float	4	S	x	x
VALUE LIN. MIN.	2	195	Simple	Float	4	S	x	x
VALUE LIN. MAX.	2	196	Simple	Float	4	S	x	x
TOTALIZER 1	2	197	Simple	Float	4	D	x	
TOTALIZER 2	2	198	Simple	Float	4	D	x	
LIN. MEASURAND	2	199	Simple	Unsigned8	1	S	x	x
LINd. MEASURAND	2	200	Simple	Unsigned8	1	S	x	x
COMB.MEASURAND	2	201	Simple	Unsigned8	1	S	x	x
TABLE SELECTION	2	202	Simple	Unsigned8	1	S	x	x
TABLE EDITOR	2	203	Simple	Unsigned8	1	S	x	x
AREA UNIT	2	204	Simple	Unsigned16	2	S	x	x
SIM. PRESSURE	2	205	Simple	Float	4	D	x	x
PRESSURE ABS RNG	2	206	Simple	Float	4	Cst	x	
PRESSURE INVERT	2	207	Simple	Unsigned8	1	N	x	x
HEIGHT UNIT	2	240	Simple	Unsigned16	2	S	x	x
CALIBRATION MODE	2	241	Simple	Unsigned8	1	S	x	x
EMPTY HEIGHT	2	242	Simple	Float	4	S	x	x
FULL HEIGHT	2	243	Simple	Float	4	S	x	x
DENSITY UNIT	2	244	Simple	Unsigned16	2	S	x	x
ADJUST DENSITY	2	245	Simple	Float	4	S	x	x
PROCESS DENSITY	2	246	Simple	Float	4	S	x	x
MEAS.LEVEL EASY	2	247	Simple	Float	4	N	x	x
LEVEL SELECTION	2	248	Simple	Unsigned8	1	S	x	x
OUTPUT UNIT	2	249	Simple	Unsigned16	2	S	x	x

1) can only be reset

6.3.10 Data format

In the case of PROFIBUS PA, the cyclic transmission of analog values to the PLC is effected in data blocks 5 bytes long. The measured value is portrayed in the first 4 bytes in the form of floating point numbers in accordance with IEEE standard. The 5th byte contains standardized status information belonging to the device.

Byte 1	Byte 2	Byte 3	Byte 4	Byte 5
Measured value as IEEE 754 floating point number				Status

The measured value is transmitted as an IEEE 754 floating point number as follows:

$$\text{Measured value} = (-1)^{\text{sign}} \times 2^{(E - 127)} \times (1 + F)$$

D15	D14	D13	D12	D11	D10	D9	D8	D7	D6	D5	D4	D3	D2	D1	D0
Sign	Exponent (E)								Fraction (F)						
	2 ⁷	2 ⁶	2 ⁵	2 ⁴	2 ³	2 ²	2 ¹	2 ⁰	2 ⁻¹	2 ⁻²	2 ⁻³	2 ⁻⁴	2 ⁻⁵	2 ⁻⁶	2 ⁻⁷
Fraction (F)															
2 ⁻⁸	2 ⁻⁹	2 ⁻¹⁰	2 ⁻¹¹	2 ⁻¹²	2 ⁻¹³	2 ⁻¹⁴	2 ⁻¹⁵	2 ⁻¹⁶	2 ⁻¹⁷	2 ⁻¹⁸	2 ⁻¹⁹	2 ⁻²⁰	2 ⁻²¹	2 ⁻²²	2 ⁻²³

Example

40 F0 00 00 hex = 0100 0000 1111 000 000 000 0000 binary

$$\begin{aligned} \text{Value} &= (-1)^0 \times 2^{(129 - 127)} \times (1 + 2^{-1} + 2^{-2} + 2^{-3}) \\ &= 1 \times 2^2 \times (1 + 0.5 + 0.25 + 0.125) \\ &= 1 \times 4 \times 1.875 \\ &= 7.5 \end{aligned}$$

- Not all programmable logic controllers support the IEEE 754-format. A conversion module must then be used or written.
- Depending on the type of data management (Most-Significant-Byte or Low-Significant-Byte) used in the PLC (master), it may also be necessary to change the byte sequence (byte-swapping routine).

Data strings

Some data types, e.g. DS-36, are listed in the slot/index table. These data types are data strings, structured according to PROFIBUS PA Specification Part 1, Version 3.x. They consist of several elements that are addressed by means of the slot, index and sub-index:

Parameter name	Type	Slot	Index	Element	Sub-index	Type	Size (byte)
OUT	DS-33	1	26	OUT VALUE	1	Float	4
				OUT STATUS	5	Unsigned8	1

Parameter name	Type	Slot	Index	Element	Sub-index	Type	Size (byte)
OUT SCALE	DS-36	1	28	EU_100_PERCENT	1	Float	4
				EU_0_PERCENT	5	Float	4
				UNITS_INDEX	9	Unsigned16	2
				DECIMAL POINT	11	Integer8	1

6.4 Onsite operation – onsite display connected

If the onsite display is connected, the three operating keys are used to navigate through the operating menu, → 26, Kap. 6.2.3 "Function of the operating elements – onsite display connected".

6.4.1 General structure of the operating menu

The menu is split into four levels. The three upper levels are used to navigate while you use the bottom level to enter numerical values, select options and save settings. The entire menu is illustrated in Section 10.1 "Menu".

The structure of the OPERATING MENU depends on the measuring mode selected, e.g. if the "Pressure" measuring mode is selected, only the functions necessary for this mode are displayed.

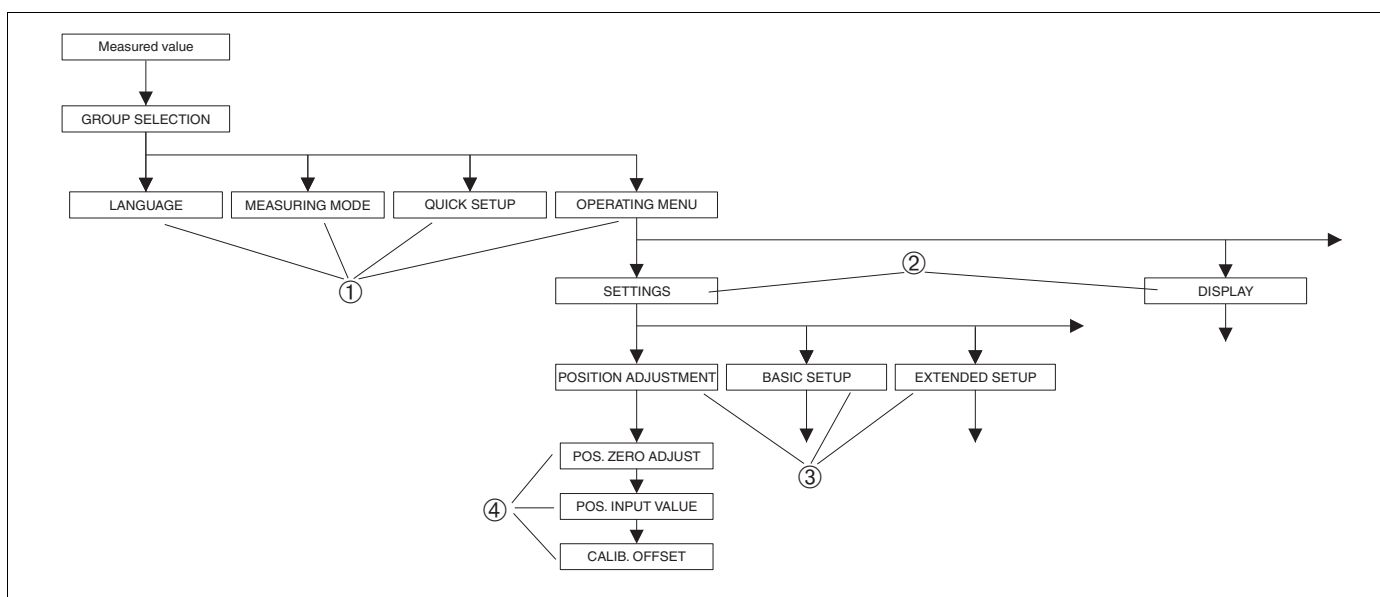

Fig. 17: General structure of the operating menu

- 1 1. Selection level
- 2 2. Selection level
- 3 Function groups
- 4 Parameter

Note! The LANGUAGE and MEASURING MODE parameters are only displayed via the onsite display on the 1st selection level. In FieldCare, the LANGUAGE parameter is displayed in the DISPLAY group and the MEASURING MODE parameter is displayed in the QUICK SETUP menus or in the BASIC SETUP function group.

6.4.2 Selecting an option

Example: select "English" as the language of the menu.

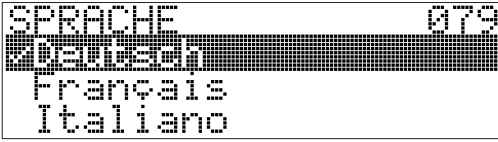
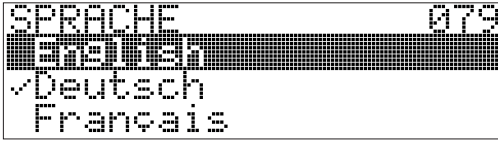
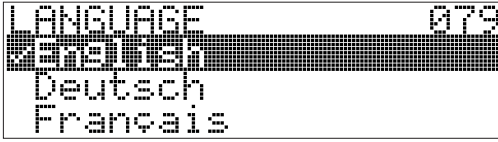
Onsite display	Operation
 <p>SPRACHE 079 3 DEUTSCH Français Italiano</p> <p><small>P01-xxxxxxxx-19-xx-xx-xx-017</small></p>	<p>German is selected as the language. A 3 in front of the menu text indicates the active option.</p>
 <p>SPRACHE 079 3 Englisch ✓Deutsch Français</p> <p><small>P01-xxxxxxxx-19-xx-xx-xx-033</small></p>	<p>Select English with "+" or "-".</p>
 <p>LANGUAGE 079 3 Englisch Deutsch Français</p> <p><small>P01-xxxxxxxx-19-xx-xx-xx-034</small></p>	<ol style="list-style-type: none"> 1. Confirm your choice with "E". A 3 in front of the menu text indicates the active option. (English is now selected as the menu language.) 2. Jump to the next item with "E".

6.4.3 Taking pressure applied at device as value

Example: performing position adjustment.

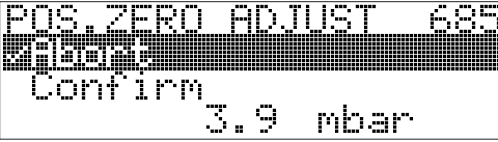
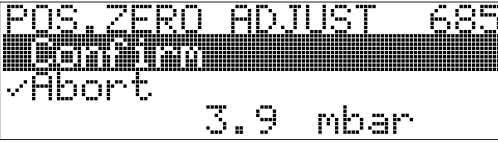
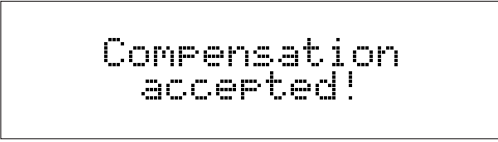
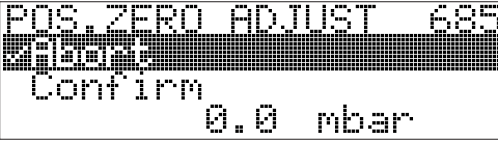
Onsite display	Operation
 <p>POS. ZERO ADJUST 685 3 Abort Confirm 3.9 mbar</p> <p><small>P01-xxxxxxxx-19-xx-xx-xx-158</small></p>	<p>The bottom line on the onsite display displays the pressure present, here 3.9 mbar.</p>
 <p>POS. ZERO ADJUST 685 Confirm ✓Abort 3.9 mbar</p> <p><small>P01-xxxxxxxx-19-xx-xx-xx-159</small></p>	<p>Use "+" or "-" to switch to the "Confirm" option. The active selection is highlighted in black.</p>
 <p>Compensation accepted!</p> <p><small>P01-xxxxxxxx-19-xx-xx-xx-037</small></p>	<p>Use "E" to assign the value (3.9 mbar) to the POS. ZERO ADJUST parameter. The device confirms the calibration and jumps back to the parameter, here POS. ZERO ADJUST (see next graphic).</p>
 <p>POS. ZERO ADJUST 685 3 Abort Confirm 0.0 mbar</p> <p><small>P01-xxxxxxxx-19-xx-xx-xx-160</small></p>	<p>Switch to the next parameter with "E".</p>

6.4.4 Editing a value

Example: adjusting DAMPING VALUE function from 2.0 s to 30.0 s. → 26, Kap. 6.2.3 "Function of the operating elements – onsite display connected".

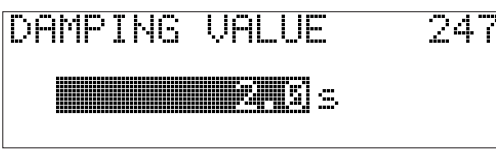
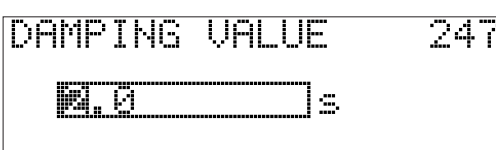
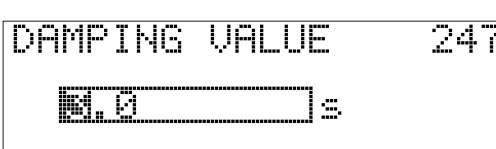
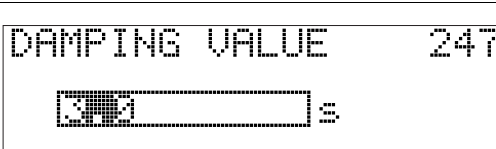
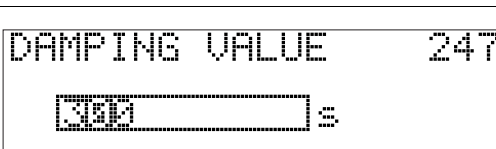
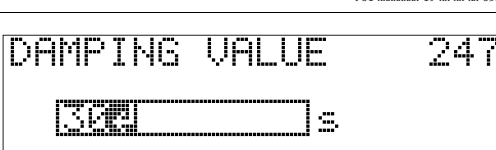
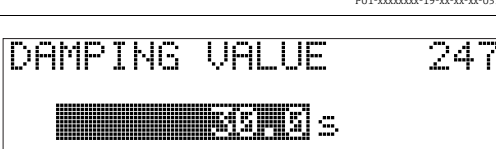
Onsite display	Operation
 <p style="text-align: right; font-size: small;">P01-xxxxxxxx-19-xx-xx-xx-023</p>	<p>The onsite display shows the parameter to be changed. The value highlighted in black can be changed. The "s" unit is fixed and cannot be changed.</p>
 <p style="text-align: right; font-size: small;">P01-xxxxxxxx-19-xx-xx-xx-027</p>	<ol style="list-style-type: none"> 1. Press "+" or "-" to get to the editing mode. 2. The first digit is highlighted in black.
 <p style="text-align: right; font-size: small;">P01-xxxxxxxx-19-xx-xx-xx-028</p>	<ol style="list-style-type: none"> 1. Use "+" to change "2" to "3". 2. Confirm "3" with "E". The cursor jumps to the next position (highlighted in black).
 <p style="text-align: right; font-size: small;">P01-xxxxxxxx-19-xx-xx-xx-029</p>	<p>The decimal point is highlighted in black, i.e. you can now edit it.</p>
 <p style="text-align: right; font-size: small;">P01-xxxxxxxx-19-xx-xx-xx-030</p>	<ol style="list-style-type: none"> 1. Keep pressing "+" or "-" until "0" is displayed. 2. Confirm "0" with "E". The cursor jumps to the next position. ↵ is displayed and is highlighted in black. → See next graphic.
 <p style="text-align: right; font-size: small;">P01-xxxxxxxx-19-xx-xx-xx-031</p>	<p>Use "E" to save the new value and exit the editing mode. → See next graphic.</p>
 <p style="text-align: right; font-size: small;">P01-xxxxxxxx-19-xx-xx-xx-032</p>	<p>The new value for the damping is now 30.0 s.</p> <ul style="list-style-type: none"> - Jump to the next parameter with "E". - You can get back to the editing mode with "+" or "-".

6.5 FieldCare

FieldCare is an Endress+Hauser asset management tool based on FDT technology. With FieldCare, you can configure all Endress+Hauser devices as well as devices from other manufacturers that support the FDT standard. Hardware and software requirements you can find on the internet: www.endress.com → select your country → Search: FieldCare → FieldCare Technical Data.

FieldCare supports the following functions:

- Configuration of transmitters in online operation
- Loading and saving device data (upload/download)
- HistoROM[®]/M-DAT analysis
- Documentation of the measuring point

Connection options:

- PROFIBUS PA via segment coupler and PROFIBUS interface card
- PROFIBUS PA via Fieldgate FXA720, segment coupler and PROFIBUS interface card
- In the "Level Standard" measuring mode, the configuration data that were loaded with FDT upload cannot be written again (FDT download). These data are only used to document the measuring point.
- Further information on the FieldCare can be found on the Internet (<http://www.endress.com>, Download → Search for: FieldCare).

6.6 HistoROM[®]/M-DAT (optional)

NOTICE

Device could be destroyed!

Detach HistoROM[®]/M-DAT from the electronic insert or attach it to the insert in a deenergized state only.

HistoROM[®]/M-DAT is a memory module, which is attached to the electronic insert and fulfils the following functions:

- Back-up copy of configuration data
- Copying configuration data of a transmitter into another transmitter
- Cyclic recording of pressure and sensor-temperature measured values
- Recording diverse events, such as alarms, configuration changes, counters for measuring range undershooting and exceeding for pressure and temperature, exceeding and undershooting the user limits for pressure and temperature, etc.
- The HistoROM[®]/M-DAT module may be retrofitted at any time (Order No.: 52027785).
- The HistoROM data and the data in the device are analyzed once a HistoROM[®]/M-DAT is attached to the electronic insert and power is reestablished to the device. During the analysis, the messages "W702, HistoROM data not consistent" and "W706, Configuration in HistoROM and device not identical" can occur. For measures →  69, Kap. 9.1 "Messages."

6.6.1 Copying configuration data

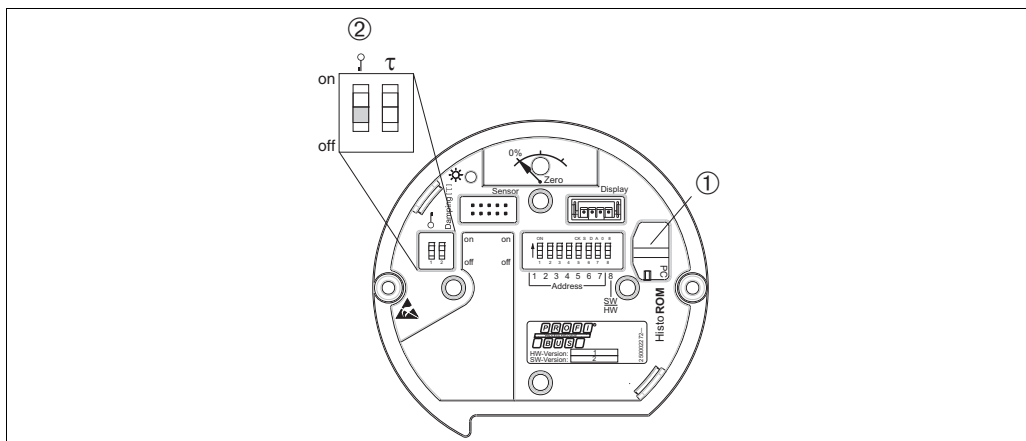

P01-xxxxxxx-19-xx-xx-xx-110

Electronic insert with optional HistoROM[®]/M-DAT memory module

- 1 Optional HistoROM[®]/M-DAT
- 2 To copy configuration data from the HistoROM[®]/M-DAT to a device or from a device to a HistoROM[®]/M-DAT, the operation must be unlocked (DIP switch 1, position "Off", parameter INSERT PIN No = 2457). See also → 53, Kap. 6.7, "Locking/unlocking operation".

Onsite operation via onsite display (optional) or remote operation

Copying configuration data from a device to a HistoROM[®]/M-DAT:

The operation must be unlocked.

1. Disconnect device from supply voltage.
2. Remove protective cap, attach the HistoROM[®]/M-DAT module to the electronic insert.
3. Reestablish supply voltage to the device.
4. The DOWNLOAD SELECT. parameter (OPERATION menu) setting has no influence on an upload from the device into HistoROM.
5. Using the HistoROM CONTROL parameter (OPERATION menu) select the option "Device → HistoROM" as the data transfer direction.
6. Wait approx. 20 seconds. Configuration data are loaded from the device to the HistoROM[®]/M-DAT. The device is not restarted.
7. Disconnect device from the supply voltage again.
8. Detach memory module.
9. Reestablish supply voltage to the device.

Copying configuration data from a HistoROM®/M-DAT to a device:

The operation must be unlocked.

1. Disconnect device from supply voltage.
2. Attach the HistoROM®/M-DAT module to the electronic insert. Configuration data from another device are stored in the HistoROM®/M-DAT.
3. Reestablish supply voltage to the device.
4. Use the DOWNLOAD SELECT parameter (OPERATION menu) to select which parameters are to be overwritten.

The following parameters are overwritten according to the selection:

– **Configuration copy (default):**

all parameters except DEVICE SERIAL No., DEVICE DESIGN, TAG, DESCRIPTION, IDENT_NUMBER_SEL, BUS ADDRESS and the parameters in the POSITION ADJUSTMENT, PROCESS CONNECTION, SENSOR TRIM and SENSOR DATA group.

– **Device replacement:**

all parameters except DEVICE SERIAL No., IDENT_NUMBER_SEL, DEVICE DESIGN and the parameters in the POSITION ADJUSTMENT, PROCESS CONNECTION, SENSOR TRIM and SENSOR DATA group.

– **Electronics replacement:**

all parameters except the parameters in the SENSOR DATA group.

Factory setting: Configuration copy

5. Using the HistoROM CONTROL parameter (OPERATING menu) select the option "HistoROM → Device" as the data transfer direction.
6. Wait approx. 45 seconds. Configuration data are loaded from the device to the HistoROM®/M-DAT. The device is restarted.
7. Before removing the HistoROM®/M-DAT again from the electronic insert, disconnect the device from supply voltage.

6.7 Locking/unlocking operation

Once you have entered all the parameters, you can lock your entries against unauthorized and undesired access.

You have the following possibilities for locking/unlocking the operation:

- Via a DIP-switch on the electronic insert, locally on the display.
- Via the onsite display (optional).
- Via communication e.g. FieldCare.

The -symbol on the onsite display indicates that operation is locked. Parameters which refer to how the display appears, e.g. LANGUAGE and DISPLAY CONTRAST can still be altered.



If operation is locked by means of the DIP-switch, you can only unlock operation again by means of the DIP-switch. If operation is locked by means of remote operation e.g. FieldCare, you can only unlock operation again by means of remote operation.

The table provides an overview of the locking functions:

Locking via	View/read parameter	Modify/write via ¹⁾		Unlocking via		
		Onsite display	Remote operation	DIP-switch	Onsite display	Remote operation
DIP-switch	Yes	No	No	Yes	No	No
Onsite display	Yes	No	No	No	Yes	Yes
Remote operation	Yes	No	No	No	Yes	Yes

1) Parameters which refer to how the display appears, e.g. LANGUAGE and DISPLAY CONTRAST can still be altered.

6.7.1 Locking/unlocking operation locally via DIP-switch

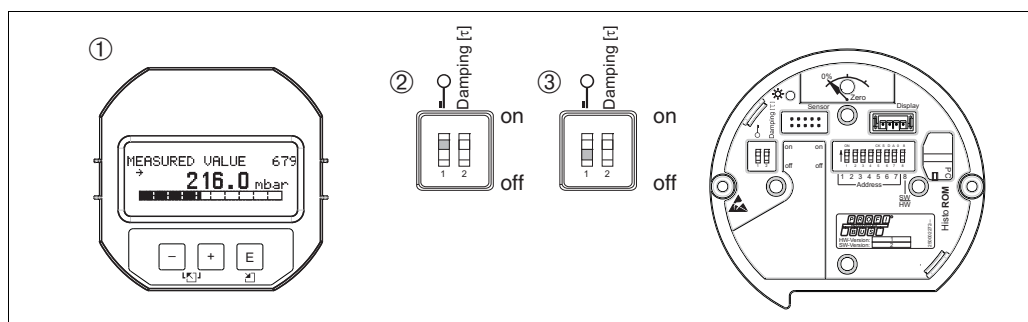

P01-xxxxxxxx-19-xx-xx-xx-111

Fig. 18: DIP-switch position "Hardware locking" on the electronic insert

- 1 If necessary, remove onsite display (optional)
- 2 DIP-switch is at "On": operation is locked.
- 3 DIP-switch is at "Off": operation is unlocked (operation possible)

6.7.2 Locking/unlocking operation via remote operation

	Description
Locking operation	<ol style="list-style-type: none"> Select INSERT PIN No parameter, menu path onsite display: GROUP SELECTION → OPERATING MENU → OPERATING → INSERT PIN No. menu path FieldCare: MANUFACTOR VIEW → OPERATING MENU → OPERATION → INSERT PIN No. To lock operation, enter "0" for the parameter.
Unlocking operation	<ol style="list-style-type: none"> Select INSERT PIN No. parameter. To unlock operation, enter "2457" for the parameter.

6.8 Factory setting (reset)

- Total reset: Press zero-key for at least 12 seconds. If the LED on the electronic insert lights up briefly, the reset is being carried out.
- By entering a certain code, you can completely, or partially, reset the entries for the parameters to the factory settings. (→ For the factory settings see Operating Instructions BA00296P "Cerabar S/Deltabar S/Deltapilot S Description of Device Functions".) Enter the code by means of the ENTER RESET CODE parameter (menu path: MANUFACTOR VIEW → OPERATING MENU → OPERATING). There are various reset codes for the device. The following table illustrates which parameters are reset by the particular reset codes. Operation must be unlocked to reset parameters (→ 53, Kap. 6.7).



- Any customer-specific configuration carried out by the factory is not affected by a reset (customer-specific configuration remains). If, after a reset, you wish the parameters to be reset to the factory settings, please contact Endress+Hauser Service.
- The OUT value may have to be rescaled after resetting with code 1, 40864 or 33333. → 66, Kap. 7.8 "Scaling the OUT value" and → 32, Kap. 6.3.6 "System integration".

Reset code	Description and effect
1 or 40864	<p>Total reset</p> <ul style="list-style-type: none"> - This reset resets the following parameters: <ul style="list-style-type: none"> - POSITION ADJUSTMENT function group - BASIC SETUP function group - EXTENDED SETUP function group - LINEARISATION function group (an existing linearization table is deleted) - TOTALIZER SETUP function group - OUTPUT group - PA DATA function group, SET UNIT TO BUS, 2ND CYCLIC VALUE, SEL.DISPLAY VALUE parameters - TRANSMITTER DATA function group, TAG, ADDITIONAL INFO. parameters - MESSAGES function group - All configurable messages ("Error" type) are set to "Warning". → 69, Kap. 9.1 "Messages" and Kap. 9.2 "Response of outputs to errors". - USER LIMITS function group - The bus address is not affected. - Any simulation which may be running is ended. - The device is restarted.

Reset code	Description and effect
33333	<p>User reset</p> <ul style="list-style-type: none"> - This reset resets the following parameters: <ul style="list-style-type: none"> - POSITION ADJUSTMENT function group - BASIC SETUP function group, apart from customer-specific units - EXTENDED SETUP function group - TOTALIZER SETUP function group - OUTPUT group - PA DATA function group, SET UNIT TO BUS, 2ND CYCLIC VALUE, SEL.DISPLAY VALUE parameters - TRANSMITTER DATA function group, TAG, ADDITIONAL INFO. parameters - Any simulation which may be running is ended. - The device is restarted.
35710	<p>Reset Level measuring mode</p> <ul style="list-style-type: none"> - Depending on the settings for the LEVEL MODE, LIN MEASURAND, LIND MEASURAND or COMB. MEASURAND parameters, the parameters needed for this measuring task will be reset. - Any simulation which may be running is ended. - The device is restarted. <p>Example LEVEL MODE = linear and LIN. MEASURAND = level</p> <ul style="list-style-type: none"> ■ HEIGHT UNIT = m ■ CALIBRATION MODE = wet ■ EMPTY CALIB. = 0 ■ FULL CALIB. = Sensor end value converted to mH₂O, e.g. 5.99 mH₂O for a 500 mbar (7.5 psi) sensor
34846	<p>Display reset</p> <ul style="list-style-type: none"> - This reset resets all parameters which have to do with how the display appears (DISPLAY group). - Any simulation which may be running is ended. - The device is restarted.
41888	<p>HistoROM reset</p> <p>The measured value and event buffers are deleted. During the reset, the HistoROM has to be attached to the electronic insert.</p>
2506	<p>PowerUp reset (warm start)</p> <ul style="list-style-type: none"> - This reset resets all the parameters in the RAM. Data are read back anew from the EEPROM (processor is initialized again). - Any simulation which may be running is ended. - The device is restarted.
2712	<p>Bus address reset</p> <ul style="list-style-type: none"> - The device address configured via the bus is reset to the 126 factory setting. - Any simulation which may be running is ended. - The device is restarted.

7 Commissioning

The device is configured for the "level" measuring mode and level selection "Level Easy Pressure" as standard. The measuring range and the unit in which the measured value is transmitted, as well as the digital output value of the Analog Input Block OUT, correspond to the data on the nameplate. Following a reset with code 1, 40864 or 33333 the OUT Value may have to be rescaled (→ [§ 66](#), Kap. 7.8 "Scaling the OUT value" and → [§ 67](#), "System units (SET UNIT TO BUS)).

⚠ WARNING

Exceeding the maximum allowable working pressure!

Risk of injury due to bursting of parts! Warning messages are generated if pressure is too high.

- ▶ If a pressure greater than the maximum permitted pressure is present at the device, the messages "E115 Sensor overpressure" and "E727 Sensor pressure error - overrange" are output in succession! Use the device only within the sensor range limits

NOTICE

Shortfall of the allowable working pressure!

Output of messages if pressure is too low.

- ▶ If a pressure smaller than the minimum permitted pressure is present at the device, the messages "E120 Sensor low pressure" and "E727 Sensor pressure error - overrange" are output in succession! Use the device only within the sensor range limits

7.1 Configuring messages

- Messages E727, E115 and E120 are "Error"-type messages and can be configured as a "Warning" or an "Alarm". These messages are configured as "Warning" messages at the factory. This setting prevents the current output from assuming the set alarm current value for applications (e.g. cascade measurement) where the user is consciously aware of the fact that the sensor range can be exceeded
- We recommend setting messages E727, E115 and E120 to "Alarm" in the following instances:
 - The sensor range does not have to be exceeded for the measuring application.
 - Position adjustment has to be carried out that has to correct a large measured error as a result of the orientation of the device (e.g. devices with a diaphragm seal).

7.2 Function check

Carry out a post-installation and a post-connection check as per the checklist before commissioning the device.

- "Post-installation check" checklist → see Kap. 4.5
- "Post-connection check" checklist → see Kap. 5.4

7.3 Commissioning via Class 2 master (FieldCare)

Commissioning and operating of FieldCare are described in the integrated FieldCare online help.

Proceed as follows to commission the device:

1. Check the hardware write protection on the electronic insert (→ [Fig 53](#), Kap. 6.7 "Locking/unlocking operation").
The DIP STATUS parameter shows the status of the hardware write protection (menu path: MANUFACTURER VIEW → TRANSMITTER INFO → TRANSMITTER DATA)
2. Enter the tag name by means of the ADDITIONAL INFO parameter. (Menu path: MANUFACTURER VIEW → TRANSMITTER INFO → TRANSMITTER DATA or PROFILE VIEW → PB PARAMETER → DEVICE)
3. Assign the device an address in the bus (→ [Fig 30](#), Kap. 6.3.5 "Device identification and addressing")
4. Configure manufacturer-specific device parameters via the MANUFACTURER VIEW menu.
5. Configure the PHYSICAL BLOCK (menu path: PROFILE VIEW → PHYSICAL BLOCK)
6. Configure the ANALOG INPUT BLOCK.
 - In the Analog Input Block, the input value or input range can be scaled in accordance with the requirements of the automation system (→ [Fig 66](#), Kap. 7.8 "Scaling the OUT value") or perform SET.UNIT.TO.BUS (Kap. 7.9).
 - If necessary, configure the limit values.
7. Configure cyclic data transmission (→ [Fig 32](#), Kap. 6.3.6 "System integration" and → [Fig 34](#), Kap. 6.3.7 "Cyclic data exchange").

7.4 Selecting language and measuring mode

7.4.1 Local operation

The LANGUAGE and MEASURING MODE parameters are located on the top menu level.
→ [Fig 47](#), Kap. 6.4.1 "General structure of the operating menu".

The following languages are available:

- Deutsch
- English
- Français
- Italiano
- Español
- Nederlands
- Chinese (CHS)
- Japanese (JPN)

The following measuring modes are available:

- Pressure
- Level

7.4.2 FieldCare

The MEASURING MODE parameter is displayed in the QUICK SETUP menus and in the BASIC SETUP function group (OPERATING MENU → SETTINGS → BASIC SETUP).

The following measuring modes are available:

- Pressure
- Level

The LANGUAGE parameter is arranged in the DISPLAY group (OPERATING MENU → DISPLAY).

- Use the LANGUAGE parameter to select the menu language for the onsite display.
- Select the menu language for FieldCare by means of the "Language Button" in the configuration window. Select the menu language for the FieldCare frame via the "Extra" menu → "Options" → "Display" → "Language".

The following languages are available:

- Deutsch
- English
- Français
- Italiano
- Español
- Nederlands
- Chinese (CHS)
- Japanese (JPN)

7.5 Position adjustment

Due to the orientation of the device, there may be a shift in the measured value, i.e. when the container is empty or partly filled, the measured value parameter does not display zero. There are three options to choose from when performing position adjustment.

- Menu path onsite display: GROUP SELECTION → OPERATING MENU → SETTINGS → POSITION ADJUSTMENT
- Menu path FieldCare: MANUFACTURER VIEW → OPERATING MENU → SETTINGS → POSITION ADJUSTMENT

Parameter name	Description
POS. ZERO ADJUST Entry	<p>Position adjustment – the pressure difference between zero (set point) and the measured pressure need not be known.</p> <p>Example:</p> <ul style="list-style-type: none"> – MEASURED VALUE = 2.2 mbar (0.032 psi) – Correct the MEASURED VALUE via the POS. ZERO ADJUST parameter with the "Confirm" option. This means that you are assigning the value 0.0 to the pressure present. – MEASURED VALUE (after pos. zero adjust) = 0.0 mbar <p>The CALIB. OFFSET parameter displays the resulting pressure difference (offset) by which the MEASURED VALUE was corrected.</p> <p>Factory setting: 0.0</p>
POS. INPUT VALUE Entry	<p>Position adjustment – the pressure difference between zero (set point) and the measured pressure need not be known. To correct the pressure difference, you need a reference measurement value (e. g. from a reference device).</p> <p>Example:</p> <ul style="list-style-type: none"> – MEASURED VALUE = 0.5 mbar (0.0073 psi) – For the POS. INPUT VALUE parameter, specify the desired set point for the MEASURED VALUE, e.g. 2.0 mbar (0.029 psi). ($\text{MEASURED VALUE}_{\text{new}} = \text{POS. INPUT VALUE}$) – MEASURED VALUE (after entry for POS. INPUT VALUE) = 2.0 mbar (0.029 psi) – The CALIB. OFFSET parameter displays the resulting pressure difference (offset) by which the MEASURED VALUE was corrected. $\text{CALIB. OFFSET} = \text{MEASURED VALUE}_{\text{old}} - \text{POS. INPUT VALUE}$, here: $\text{CALIB. OFFSET} = 0.5 \text{ mbar (0.0073 psi)} - 2.0 \text{ mbar (0.029 psi)} = -1.5 \text{ mbar (0.022 psi)}$ <p>Factory setting: 0.0</p>
CALIB. OFFSET Entry	<p>Position adjustment – the pressure difference between zero (set point) and the measured pressure is known.</p> <p>Example:</p> <ul style="list-style-type: none"> – MEASURED VALUE = 2.2 mbar (0.032 psi) – Via the CALIB. OFFSET parameter, enter the value by which the MEASURED VALUE should be corrected. To correct the MEASURED VALUE to 0.0 mbar, you must enter the value 2.2 here. ($\text{MEASURED VALUE}_{\text{new}} = \text{MEASURED VALUE}_{\text{old}} - \text{CALIB. OFFSET}$) – MEASURED VALUE (after entry for calib. offset) = 0.0 mbar <p>Factory setting: 0.0</p>

7.6 Level measurement

7.6.1 Information on level measurement

- The Level and Pressure operating modes each have a quick setup menu which guides you through the most important basic functions. →  62 "Quick Setup menu for the Level measuring mode".
- Furthermore, the three level modes "Level Easy Pressure", "Level Easy Height" and "Level Standard" are available to you for level measurement. You can select from the "Linear", "Pressure linearized" and "Height linearized" level types for the "Level Standard" level mode. The table in the "Overview of level measurement" section below provides an overview of the various measuring tasks.
 - In the "Level Easy Pressure" and "Level Easy Height" level modes, the values entered are not tested as extensively as in the "Level Standard" level mode. The values entered for EMPTY CALIB./FULL CALIB., EMPTY PRESSURE/FULL PRESSURE and EMPTY HEIGHT/FULL must have a minimum interval of 1% for the "Level Easy Pressure" and "Level Easy Height" level modes. The value will be rejected with a warning message if the values are too close together. Further limit values are not checked; i.e. the values entered must be appropriate for the sensor and the measuring task so that the measuring device can measure correctly.
 - The "Level Easy Pressure" and "Level Easy Height" level modes encompass fewer parameters than the "Level Standard" mode and are used for quick and easy configuration of a level application.
 - Customer-specific units of fill level, volume and mass or a linearization table may only be entered in the "Level Standard" level mode.
- For a detailed description of the parameters and configuration examples, see Operating Instructions BA00296P "Cerabar S/Deltabar S/Deltapilot S, Description of Device Functions.

WARNING

Changing the measuring mode affects the span (URV)!

This situation can result in product overflow.

- ▶ If the measuring mode is changed, the span setting (URV) must be verified in the "Calibration" → "Basic Setup" operating menu and, if necessary, reconfigured!

7.6.2 Overview of level measurement

Measuring task	LEVEL SELECTION/ LEVEL MODE	Measured variable options	Description	Comment	Measured value display
The measured variable is in direct proportion to the measured pressure. Calibration is performed by entering two pressure-level value pairs.	LEVEL SELECTION: Level Easy Pressure	Via OUTPUT UNIT parameter: %, level, volume or mass units.	<ul style="list-style-type: none"> - Calibration with reference pressure – wet calibration, see Operating Instructions BA00296P. - Calibration without reference pressure – dry calibration, see Operating Instructions BA00296P. 	<ul style="list-style-type: none"> - Incorrect entries are possible - Customized units are not possible 	The measured value display and the LEVEL BEFORE LIN parameter show the measured value.
The measured variable is in direct proportion to the measured pressure. Calibration is performed by entering the density and two height-level value pairs.	LEVEL SELECTION: Level Easy Height	Via OUTPUT UNIT parameter: %, level, volume or mass units.	<ul style="list-style-type: none"> - Calibration with reference pressure – wet calibration, see Operating Instructions BA00296P. - Calibration without reference pressure – dry calibration, see Operating Instructions BA00296P. 	<ul style="list-style-type: none"> - Incorrect entries are possible - Customized units are not possible 	The measured value display and the LEVEL BEFORE LIN parameter show the measured value.
The measured variable is in direct proportion to the measured pressure.	LEVEL SELECTION: Level standard/ LEVEL MODE: Linear	Via LIN. MEASURAND parameter: <ul style="list-style-type: none"> - % (level) - Level - Volume - Mass 	<ul style="list-style-type: none"> - Calibration with reference pressure – wet calibration, see Operating Instructions BA00296P. - Calibration without reference pressure – dry calibration, see Operating Instructions BA00296P. 	<ul style="list-style-type: none"> - Incorrect entries are rejected by the device - Customized level, volume and mass units are possible 	The measured value display and the LEVEL BEFORE LIN parameter show the measured value.
The measured variable is not in direct proportion to the measured pressure as, for example, with containers with a conical outlet. A linearization table must be entered for the calibration.	LEVEL SELECTION: Level standard/ LEVEL MODE: Pressure linearized	Via LINd. MEASURAND parameter: <ul style="list-style-type: none"> - Pressure + % - Pressure + volume - Pressure + mass 	<ul style="list-style-type: none"> - Calibration with reference pressure: semiautomatic entry of linearization table, see Operating Instructions BA00296P. - Calibration without reference pressure: manual entry of linearization table, see Operating Instructions BA00296P. 	<ul style="list-style-type: none"> - Incorrect entries are rejected by the device - Customized level, volume and mass units are possible 	The measured value display and the TANK CONTENT parameter show the measured value.
<ul style="list-style-type: none"> - Two measured variables are required or - The container shape is given by value pairs, such as height and volume. <p>The 1st measured variable %-height or height must be in direct proportion to the measured pressure. The 2nd measured variable volume, mass or % must not be in direct proportion to the measured pressure. A linearization table must be entered for the 2nd measured variable. The 2nd measured variable is assigned to the 1st measured variable by means of this table.</p>	LEVEL SELECTION: Level standard/ LEVEL MODE: Height linearized	Via COMB. MEASURAND parameter: <ul style="list-style-type: none"> - Height + volume - Height + mass - Height + % - %-Height + volume - %-Height + mass - %-Height + % 	<ul style="list-style-type: none"> - Calibration with reference pressure: wet calibration and semiautomatic entry of linearization table, see Operating Instructions BA00296P. - Calibration without reference pressure: dry calibration and manual entry of linearization table, see Operating Instructions BA00296P. 	<ul style="list-style-type: none"> - Incorrect entries are rejected by the device - Customized level, volume and mass units are possible 	<p>The measured value display and the TANK CONTENT parameter show the 2nd measured value (volume, mass or %).</p> <p>The LEVEL BEFORE LIN parameter displays the 1st measured value (%-height or height).</p>

7.6.3 Quick Setup menu for the Level measuring mode

- Some parameters are only displayed if other parameters are appropriately configured. For example, the EMPTY CALIB. parameter is only displayed in the following cases:
 - LEVEL SELECTION "Level Easy Pressure" and CALIBRATION MODE "Wet"
 - LEVEL SELECTION "Level Standard", LEVEL MODE "Linear" and CALIBRATION MODE "WET"
 You can find the LEVEL MODE parameter in the BASIC SETTINGS function group.
- The following parameters are set to the following values in the factory:
 - LEVEL SELECTION: Level Easy Pressure
 - CALIBRATION MODE: Wet
 - OUTPUT UNIT or LIN. MEASURAND: %
 - EMPTY CALIB.: 0.0
 - FULL CALIB.: 100.0
- The quick setup is suitable for simple and quick commissioning. If you wish to make more complex settings, e.g. change the unit from "%" to "m", you will have to calibrate using the BASIC SETTINGS group. → See Operating Instructions BA00296P.

▲ WARNING

Changing the measuring mode affects the span (URV)!

This situation can result in product overflow.

- ▶ If the measuring mode is changed, the span setting (URV) must be verified in the "Calibration" → "Basic Setup" operating menu and, if necessary, reconfigured!

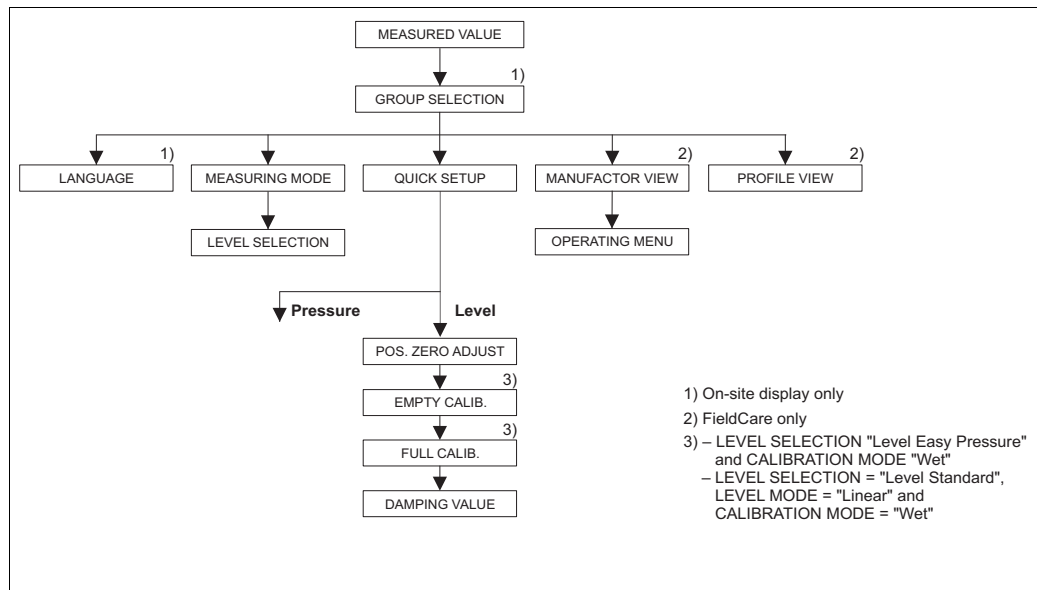



Fig. 19: Quick Setup menu for the "Level" measuring mode

Local operation	FieldCare
<p>Measured value display Onsite display: Switch from the measured value display to GROUP SELECTION with F.</p>	<p>Measured value display Select QUICK SETUP menu.</p>
<p>GROUP SELECTION Select MEASURING MODE.</p>	<p>MEASURING MODE Select "Level" option.</p>
<p>MEASURING MODE Select "Level" option.</p>	
<p>LEVEL SELECTION Select level mode. For an overview → 61.</p>	<p>LEVEL SELECTION Select level mode. For an overview → 61.</p>
<p>GROUP SELECTION Select QUICK SETUP menu.</p>	

Local operation	FieldCare
<p>POS. ZERO ADJUST Due to orientation of the device, there may be a shift in the measured value. You correct the MEASURED VALUE via the POS. ZERO ADJUST parameter with the "Confirm" option, i. e. you assign the value 0.0 to the pressure present.</p>	<p>POS.ZERO ADJUST Due to orientation of the device, there may be a shift in the measured value. You correct the MEASURED VALUE via the POS. ZERO ADJUST parameter with the "Confirm" option, i. e. you assign the value 0.0 to the pressure present.</p>
<p>EMPTY CALIB. ¹⁾ Enter level for the lower calibration point. For this parameter, enter a level value which is assigned to the pressure present at the device.</p>	<p>EMPTY CALIB. ¹⁾ Enter level for the lower calibration point. For this parameter, enter a level value which is assigned to the pressure present at the device.</p>
<p>FULL CALIB. ¹⁾ Enter level for the upper calibration point. For this parameter, enter a level value which is assigned to the pressure present at the device.</p>	<p>FULL CALIB. ¹⁾ Enter level for the upper calibration point. For this parameter, enter a level value which is assigned to the pressure present at the device.</p>
<p>DAMPING VALUE Enter damping time (time constant τ). The damping affects the speed at which all subsequent elements, such as the onsite display, measured value and OUT value of the Analog Input Block react to a change in the pressure.</p>	<p>DAMPING VALUE Enter damping time (time constant τ). The damping affects the speed at which all subsequent elements, such as the onsite display, measured value and OUT value of the Analog Input Block react to a change in the pressure.</p>

- 1) - LEVEL SELECTION "Level Easy Pressure" and CALIBRATION MODE "Wet"
 - LEVEL SELECTION "Level Standard", LEVEL MODE "Linear" and CALIBRATION MODE "Wet"

For onsite operation, see also →  26, Kap. 6.2.3 "Function of the operating elements – onsite display connected" and →  47, Kap. 6.4 "Onsite operation – onsite display connected".

7.7 Pressure measurement

7.7.1 Information on pressure measurement

- The Level and Pressure operating modes each have a quick setup menu which guides you through the most important basic functions. With the setting in the MEASURING MODE parameter, you specify which Quick Setup menu should be displayed. → 57, Kap. 7.4 "Selecting language and measuring mode".
- For a detailed description of the parameters see the Operating Instructions BA00296P "Cerabar S/Deltabar S/Deltapilot S, Description of device functions"
 - Table 6, POSITION ADJUSTMENT
 - Table 7, BASIC SETUP
 - Table 16, EXTENDED SETUP
- For differential pressure measurement, select the "Pressure" option by means of the MEASURING MODE parameter. The operating menu is structured appropriately.

⚠ WARNING

Changing the measuring mode affects the span (URV)!

This situation can result in product overflow.

- ▶ If the measuring mode is changed, the span setting (URV) must be verified in the "Calibration" → "Basic Setup" operating menu and, if necessary, reconfigured!

7.7.2 Quick Setup menu for the Pressure measuring mode

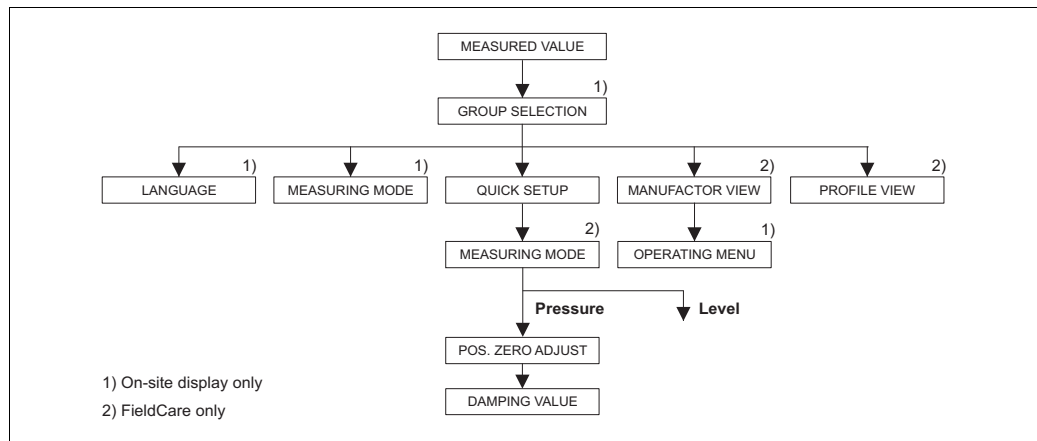



Fig. 20: Quick Setup menu for the "Pressure" measuring mode

Local operation	FieldCare
Measured value display Onsite display: Switch from the measured value display to GROUP SELECTION with F.	Measured value display Select QUICK SETUP menu.
GROUP SELECTION Select MEASURING MODE.	MEASURING MODE Select "Pressure" option.
MEASURING MODE Select "Pressure" option.	
GROUP SELECTION Select QUICK SETUP menu.	POS.ZERO ADJUST Due to orientation of the device, there may be a shift in the measured value. You correct the MEASURED VALUE via the POS. ZERO ADJUST parameter with the "Confirm" option, i. e. you assign the value 0.0 to the pressure present.
POS.ZERO ADJUST Due to orientation of the device, there may be a shift in the measured value. You correct the MEASURED VALUE via the POS. ZERO ADJUST parameter with the "Confirm" option, i. e. you assign the value 0.0 to the pressure present.	

Local operation	FieldCare
DAMPING VALUE Enter damping time (time constant τ). The damping affects the speed at which all subsequent elements, such as the onsite display, measured value and OUT value of the Analog Input Block react to a change in the pressure.	DAMPING VALUE Enter damping time (time constant τ). The damping affects the speed at which all subsequent elements, such as the onsite display, measured value and OUT value of the Analog Input Block react to a change in the pressure.

For onsite operation, see also →  26, Kap. 6.2.3 "Function of the operating elements – onsite display connected" and →  47, Kap. 6.4 "Onsite operation – onsite display connected".

7.8 Scaling the OUT value

In the Analog Input Block, the input value or input range can be scaled in accordance with the automation requirements.

Example:

The measuring range 0...500 mbar (7.5 psi) should be rescaled to 0...10000.

- Select PV SCALE group.

Menu path: PROFILE VIEW → ANALOG INPUT BLOCK → AI parameter

- Enter "0" as the LOWER VALUE.
- Enter "500" as the UPPER VALUE.

- Select OUT SCALE group.

Menu path: PROFILE VIEW → ANALOG INPUT BLOCK → AI parameter

- Enter "0" as the LOWER VALUE.
- Enter "10000" as the UPPER VALUE.
- For UNIT, select "User unit" for example.

The unit selected here does not have any effect on the scaling.

- Result:

At a pressure of 350 mbar (5.25 psi), the value 7000 is output to the PLC as the OUT value.

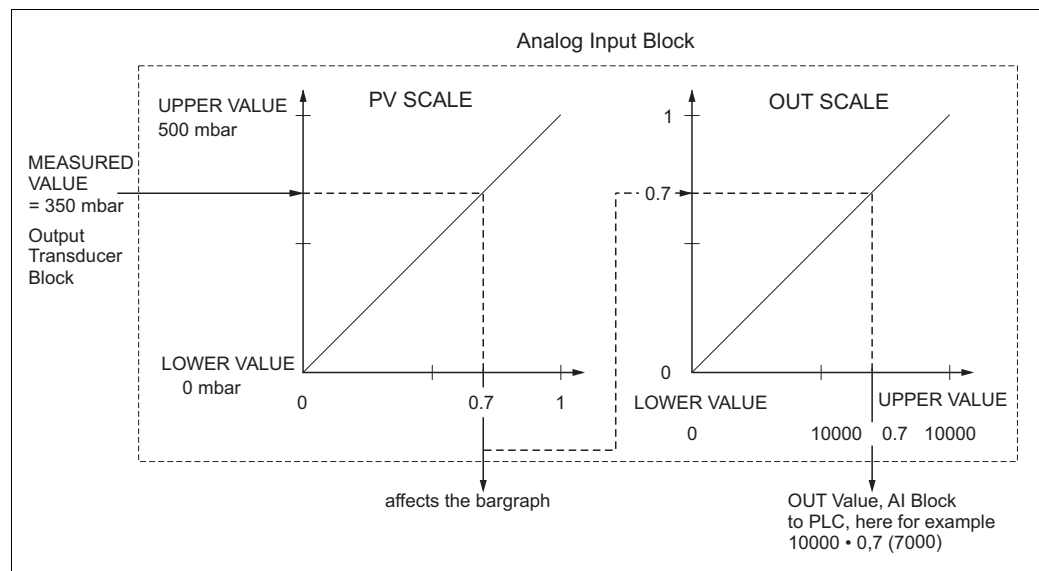

- The OUT Value can only be scaled via remote operation (e.g. FieldCare).
- When a unit changes within a measuring mode, the limits for PV SCALE are converted.
- If the operating mode is changed, no conversion takes place. The device must be recalibrated following a change in the operating mode.
- Via the "SET.UNIT.TO.BUS" parameter (menu path: TRANSMITTER INFO → PA DATA) confirm with "Accept" to adapt the scaling of the Analog Input Block automatically to the Transducer Block. The OUT unit is updated accordingly (→ Kap. 7.9).

7.9 System units (SET UNIT TO BUS)

The onsite display of Deltapilot S and the MEASURED VALUE (FieldCare) display the same value as standard. The bar graph on the onsite display corresponds to the standardized value of the Analog Input Block. The digital output value of the Analog Input Block OUT works independently of the MEASURED VALUE or of the onsite display.

The following options are available so that the onsite display or the MEASURED VALUE and the digital output value display the same value:

- Set the values for the lower and upper limit of PV SCALE and OUT SCALE in the Analog Input Block as equal (→  66, Kap. 7.8 "Scaling the OUT value"):
 - LOWER VALUE (PV SCALE) = LOWER VALUE (OUT SCALE)
 - UPPER VALUE (PV SCALE) = UPPER VALUE (OUT SCALE)
- By means of the SET UNIT TO BUS parameter, confirm the option "On" to adapt the scaling of the Analog Input Block automatically to the Transducer Block. The OUT unit assumes the value of the PV unit.

Example:

The onsite display or the MEASURED VALUE and the OUT value display 100 mbar (1.45 psi). Select the new unit "psi" by means of the PRESS. ENG. UNIT parameter.

- Display
 - Onsite display and MEASURED VALUE: 1.45 psi (100 mbar)
 - OUT value: 100 mbar (1.45 psi)
- By means of the SET UNIT TO BUS parameter, confirm the option "On".
Menu path onsite display: GROUP SELECTION → OPERATING MENU → TRANSMITTER INFO → PA DATA
- Result:
The OUT value displays 1.45 psi (100 mbar).

In the following instances, the onsite display or the MEASURED VALUE and the digital output value of the Analog Input Block OUT no longer display the same value:

- If you change the operating mode
- If you change the values for PV SCALE
- If you change the values for OUT SCALE
- If you change the unit of the primary value

CAUTION

Note Dependencies when setting parameters!

- ▶ If you confirm the SET UNIT TO BUS parameter, please note that a change in the digital output value could affect the control system

8 Maintenance

Keep the pressure compensation and GORE-TEX® filter (1) free from contamination.

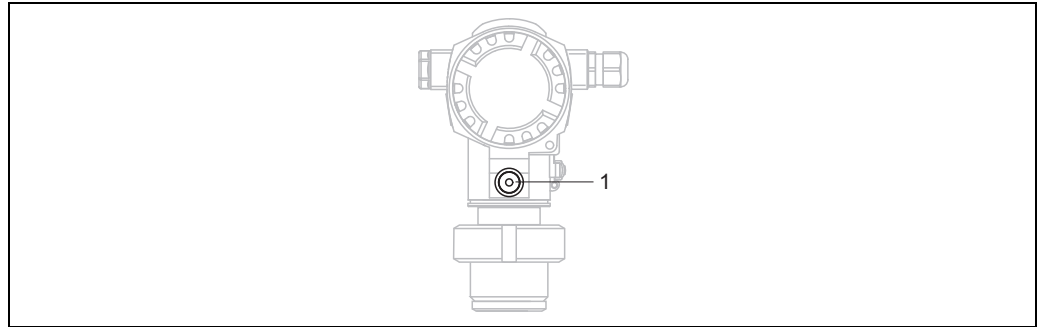

P01-FMB70xxx-17-xx-xx-xx-003

8.1 Exterior cleaning

Please note the following points when cleaning the device:

- The cleaning agents used should not attack the surface and the seals.
- Mechanical damage to the process isolating diaphragm, e.g. due to pointed objects, must be avoided.

9 Troubleshooting

9.1 Messages

The following table lists all the possible messages that can occur.

The device differentiates between the error types "Alarm", "Warning" and "Error".

You may specify whether the instrument should react as if for an "Alarm" or "Warning" for "Error" messages. → See the "Corresponds to NA 64" column and Kap. 9.2 "Response of outputs to errors".

In addition, the "Message category NE 107" column classifies the messages in accordance with NAMUR Recommendation NE 107:

- Failure (F)
- Function check (C)
- Out of specification (S)
- Maintenance required (M)

Error message display on the onsite display:

- The measured value display shows the message with the highest priority. → See "Priority" column.
- The ALARM STATUS parameter shows all the messages present in descending order of priority. You can scroll through all the messages present with the S-key or O-key.

Message display via FieldCare:

- The ALARM STATUS parameter shows the message with the highest priority. → See "Priority" column.

The device status (Device functions/Diagnostics menu) displays the status signal, the error message, cause and remedial measures.



- If the device detects a defect in the onsite display during initialization, special error messages are generated. → For the error messages → 76, Kap. 9.1.1 "Onsite display error messages".
- For support and further information, please contact Endress+Hauser Service.
- → See also Kap. 9.4 ff.
- The PROFIBUS status is updated depending on the message type, or depending on the setting for flexible alarms.

Code	Corresponds to NA 64	Message category NE 107	Message/description	Cause	Measure	Priority
101 (A101)	Alarm B	Failure (F)	F>Sensor electronic EEPROM error	<ul style="list-style-type: none"> - Electromagnetic effects are greater than specifications in the technical data. (→ See Kap. 10.) This message normally only appears briefly. - Sensor defect. 	<ul style="list-style-type: none"> - Wait a few minutes. - Restart the device. Perform reset (Code 2506 or 33062). - Block off electromagnetic effects or eliminate source of disturbance. - Replace sensor. 	17
102 (W102)	Warning C	Maintenance required (M)	M>Checksum error in EEPROM: peakhold segment	<ul style="list-style-type: none"> - Main electronics defect. Correct measurement can continue as long as you do not need the peak hold indicator function. 	<ul style="list-style-type: none"> - Replace main electronics. 	51
106 (W106)	Warning C	Function check (C)	C>Downloading - please wait	<ul style="list-style-type: none"> - Downloading. 	<ul style="list-style-type: none"> - Wait for download to complete. 	50

Code	Corresponds to NA 64	Message category NE 107	Message/description	Cause	Measure	Priority
110 (A110)	Alarm B	Failure (F)	F>Checksum error in EEPROM: configuration segment	<ul style="list-style-type: none"> - The supply voltage is disconnected when writing. - Electromagnetic effects are greater than specifications in the technical data. (→ See Kap. 10.) - Main electronics defect. 	<ul style="list-style-type: none"> - Reestablish supply voltage. Perform reset (Code 1 or 40864) if necessary. Carry out calibration again. - Block off electromagnetic effects or eliminate sources of disturbance. - Replace main electronics. 	6
113 (A113)	Alarm B	Failure (F)	F>ROM failure in transmitter electronic	<ul style="list-style-type: none"> - Main electronics defect. 	<ul style="list-style-type: none"> - Replace main electronics. 	1
115 (E115)	Error B Factory setting: Warning	Out of specification (S)	S>Sensor overpressure	<ul style="list-style-type: none"> - Overpressure present. - Sensor defect. 	<ul style="list-style-type: none"> - Reduce pressure until message disappears. - Replace sensor. 	29
116 (W116)	Warning C	Maintenance required (M)	M>Download error, repeat download	<ul style="list-style-type: none"> - The file is defect. - During the download, the data are not correctly transmitted to the processor, e.g. because of open cable connections, spikes (ripple) on the supply voltage or electromagnetic effects. 	<ul style="list-style-type: none"> - Use another file. - Check cable connection PC – transmitter. - Block off electromagnetic effects or eliminate sources of disturbance. - Perform reset (Code 1 or 40864) and carry out calibration again. - Repeat download. 	36
120 (E120)	Error B Factory setting: Warning	Out of specification (S)	S>Sensor low pressure	<ul style="list-style-type: none"> - Pressure too low. - Sensor defect. 	<ul style="list-style-type: none"> - Increase pressure until message disappears. - Replace sensor. 	30
121 (A121)	Alarm B	Failure (F)	F>Checksum error in factory segment of EEPROM	<ul style="list-style-type: none"> - Main electronics defect. 	<ul style="list-style-type: none"> - Replace main electronics. 	5
122 (A122)	Alarm B	Failure (F)	F>Sensor not connected	<ul style="list-style-type: none"> - Cable connection sensor –main electronics disconnected. - Electromagnetic effects are greater than specifications in the technical data. (→ See Kap. 10.) - Main electronics defect. - Sensor defect. 	<ul style="list-style-type: none"> - Check cable connection and repair if necessary. - Block off electromagnetic effects or eliminate source of disturbance. - Replace main electronics. - Replace sensor. 	13
130 (A130)	Alarm B	Failure (F)	F>EEPROM is defect.	<ul style="list-style-type: none"> - Main electronics defect. 	<ul style="list-style-type: none"> - Replace main electronics. 	10
131 (A131)	Alarm B	Failure (F)	F>Checksum error in EEPROM: min/max segment	<ul style="list-style-type: none"> - Main electronics defect. 	<ul style="list-style-type: none"> - Replace main electronics. 	9
132 (A132)	Alarm B	Failure (F)	F>Checksum error in totalizer EEPROM	<ul style="list-style-type: none"> - Main electronics defect. 	<ul style="list-style-type: none"> - Replace main electronics. 	7
133 (A133)	Alarm B	Failure (F)	F>Checksum error in History EEPROM	<ul style="list-style-type: none"> - An error occurred when writing. - Main electronics defect. 	<ul style="list-style-type: none"> - Perform reset (Code 1 or 40864) and carry out calibration again. - Replace main electronics. 	8
602 (W602)	Warning C	Function check (C)	C>Linearization curve not monoton	<ul style="list-style-type: none"> - The linearization table is not monotonic increasing or decreasing. 	<ul style="list-style-type: none"> - Add to or correct linearization table. Then accept linearization table again. 	55

Code	Corresponds to NA 64	Message category NE 107	Message/description	Cause	Measure	Priority
604 (W604)	Warning C	Function check (C)	C>Linearization table not valid. Less than 2 points or points too close	Note! No min. span applies for the Y-points as of software version "03.10.xx".	<ul style="list-style-type: none"> - Add to linearization table. Accept linearization table again if necessary. - Correct linearization table and accept it again. 	58
				<ul style="list-style-type: none"> - The linearization table consists of less than 2 points. - At least 2 points in the linearization table are too close together. A minimum distance of 0.5 % of the span between two points must be maintained. Spans for the "Pressure linearized" option: HYDR. PRESS MAX. - HYDR. PRESS MIN.; TANK CONTENT MAX. - TANK CONTENT MIN. Spans for the "Height linearized" option: LEVEL MAX - LEVEL MIN; TANK CONTENT MAX. - TANK CONTENT MIN. 		
613 (W613)	Warning I	Function check (C)	C>Simulation is active	- Simulation is switched on, i.e. the device is not measuring at present.	- Switch off simulation.	58
616 (W616)	Warning I	Function check (C)	C>Simulation is active (AI)	- Simulation of the AI Block is switched on, i.e. the Main Process Value (AI OUT VALUE) that is output does not correspond to the sensor signal.	- Switch off simulation of the AI Block (ANALOGINPUT BLOCK → Set the AI STANDARD PARAMETER → TARGET MODE to Automatic and set AI PARAMETER/SIMULATE to No).	58
700 (W700)	Warning C	Maintenance required (M)	M>Last configuration not stored	<ul style="list-style-type: none"> - An error occurred when writing or reading configuration data or the power supply was disconnected. - Main electronics defect. 	<ul style="list-style-type: none"> - Perform reset (Code 1 or 40864) and carry out calibration again. - Replace main electronics. 	52
702 (W702)	Warning C	Maintenance required (M)	M>HistoROM data not consistent.	<ul style="list-style-type: none"> - Data were not written correctly to the HistoROM, e.g. if the HistoROM was detached during the writing process. - HistoROM does not have any data. 	<ul style="list-style-type: none"> - Repeat upload. - Perform reset (Code 1 or 40864) and carry out calibration again. - Copy suitable data to the HistoROM. (→ 51, Kap. 6.6.1 "Copying configuration data".) 	53
703 (A703)	Alarm B	Failure (F)	F>Measurement error	<ul style="list-style-type: none"> - Fault in the main electronics. - Main electronics defect. 	<ul style="list-style-type: none"> - Briefly disconnect device from the power supply. - Replace main electronics. 	22
704 (A704)	Alarm B	Function check (C)	C>Measurement error	<ul style="list-style-type: none"> - Fault in the main electronics. - Main electronics defect. 	<ul style="list-style-type: none"> - Briefly disconnect device from the power supply. - Replace main electronics. 	12
705 (A705)	Alarm B	Failure (F)	F>Measurement error	<ul style="list-style-type: none"> - Fault in the main electronics. - Main electronics defect. 	<ul style="list-style-type: none"> - Briefly disconnect device from the power supply. - Replace main electronics. 	21

Code	Corresponds to NA 64	Message category NE 107	Message/description	Cause	Measure	Priority
706 (W706)	Warning C	Maintenance required (M)	M>Configuration in HistoROM and device not identical	<ul style="list-style-type: none"> - Configuration (parameters) in the HistoROM and in the device is not identical. 	<ul style="list-style-type: none"> - Copy data from the device to the HistoROM. (→ 51, Kap. 6.6.1 "Copying configuration data".) - Copy data from the HistoROM to the device. (→ 51, Kap. 6.6.1 "Copying configuration data".) The message remains if the HistoROM and the device have different software versions. The message goes out if you copy the data from the device to the HistoROM. - Device reset codes such as 1 or 40864 do not have any effect on the HistoROM. That means that if you do a reset, the configurations in the HistoROM and in the device may not be the same. 	57
707 (A707)	Alarm B	Function check (C)	C>X-VAL. of lin. table out of edit limits.	<ul style="list-style-type: none"> - At least one X-VALUE in the linearization table is either below the value for HYDR. PRESS MIN. or MIN. LEVEL or above the value for HYDR. PRESS. MAX. or LEVEL MAX. 	<ul style="list-style-type: none"> - Carry out calibration again. (→ See also Operating Instructions BA00296P) 	37
710 (W710)	Warning C	Function check (C)	B>Set span too small. Not allowed.	<ul style="list-style-type: none"> - Values for calibration (e.g. lower range value and upper range value) are too close together. - The sensor was replaced and the customer-specific configuration does not suit the sensor. - Unsuitable download carried out. 	<ul style="list-style-type: none"> - Adjust calibration to suit sensor. (→ See also Operating Instructions BA00296P, parameter description MINIMUM SPAN) - Adjust calibration to suit sensor. - Replace sensor with a suitable sensor. - Check configuration and perform download again. 	49
713 (A713)	Alarm B	Function check (C)	C>100% POINT level out of edit limits	<ul style="list-style-type: none"> - The sensor was replaced. 	<ul style="list-style-type: none"> - Carry out calibration again. 	38
715 (E715)	Error C Factory setting: Warning	Out of specification (S)	S>Sensor over temperature	<ul style="list-style-type: none"> - The temperature measured in the sensor is greater than the upper nominal temperature of the sensor. (→ See also Operating Instructions BA00296P, parameter description Tmax SENSOR) - Unsuitable download carried out. 	<ul style="list-style-type: none"> - Reduce process temperature/ ambient temperature. - Check configuration and perform download again. 	32
716 (E716)	Error B Factory setting: Alarm	Failure (F)	F>Sensor diaphragm broken	<ul style="list-style-type: none"> - Sensor defect. 	<ul style="list-style-type: none"> - Replace sensor. - Reduce pressure. 	24
717 (E717)	Error C Factory setting: Warning	Out of specification (S)	S>Transmitter over temperature	<ul style="list-style-type: none"> - The temperature measured in the electronics is greater than the upper nominal temperature of the electronics (+88 °C (+190 °F)). - Unsuitable download carried out. 	<ul style="list-style-type: none"> - Reduce ambient temperature. - Check configuration and perform download again. 	34

Code	Corresponds to NA 64	Message category NE 107	Message/description	Cause	Measure	Priority
718 (E718)	Error C Factory setting: Warning	Out of specification (S)	S>Transmitter under temperature	<ul style="list-style-type: none"> - The temperature measured in the electronics is smaller than the lower nominal temperature of the electronics (-43 °C (-45 °F)). - Unsuitable download carried out. 	<ul style="list-style-type: none"> - Increase ambient temperature. Insulate device if necessary. - Check configuration and perform download again. 	35
719 (A719)	Alarm B	Function check (C)	C>Y-VAL of lin. table out of edit limits	<ul style="list-style-type: none"> - At least on Y-VALUE in the linearization table is below the MIN. TANK CONTENT or above the MAX. TANK CONTENT. 	<ul style="list-style-type: none"> - Carry out calibration again. (→ See also Operating Instructions BA00296P) 	39
720 (E720)	Error C Factory setting: Warning	Out of specification (S)	S>Sensor under temperature	<ul style="list-style-type: none"> - The temperature measured in the sensor is smaller than the lower nominal temperature of the sensor. (→ See also Operating Instructions BA00296P, parameter description Tmin SENSOR) - Unsuitable download carried out. - Loose connection at sensor cable 	<ul style="list-style-type: none"> - Increase process temperature/ ambient temperature. - Check configuration and perform download again. - Wait a short period of time and tighten the connection, or avoid loose connection. 	33
721 (A721)	Alarm B	Function check (C)	C>ZERO POSITION level out of edit limits	<ul style="list-style-type: none"> - LEVEL MIN or LEVEL MAX has been changed. 	<ul style="list-style-type: none"> - Perform reset (Code 35710) and carry out calibration again. 	40
722 (A722)	Alarm B	Function check (C)	C>EMPTY CALIB. or FULL CALIB. out of edit limits	<ul style="list-style-type: none"> - LEVEL MIN or LEVEL MAX has been changed. 	<ul style="list-style-type: none"> - Perform reset (Code 35710) and carry out calibration again. 	41
725 (A725)	Alarm B	Failure (F)	F>Sensor connection error, cycle disturbance	<ul style="list-style-type: none"> - Electromagnetic effects are greater than specifications in the technical data. (→ See Kap. 10.) - Setscrew loose. - Sensor or main electronics defect. 	<ul style="list-style-type: none"> - Block off electromagnetic effects or eliminate source of disturbance. - Retighten setscrew with 1 Nm (0,74 lbf ft) (see Kap. 4.4.5). - Replace sensor or main electronics. 	25
726 (E726)	Error C Factory setting: Warning	Out of specification (S)	S>Sensor temperature error - overrange	<ul style="list-style-type: none"> - Electromagnetic effects are greater than specifications in the technical data. (→ See Kap. 10.) - Process temperature is outside permitted range. - Sensor defect. 	<ul style="list-style-type: none"> - Block off electromagnetic effects or eliminate source of disturbance. - Check temperature present, reduce or increase if necessary. - If the process temperature is within the permitted range, replace sensor. 	31
727 (E727)	Error C Factory setting: Warning	Out of specification (S)	S>Sensor pressure error - overrange	<ul style="list-style-type: none"> - Electromagnetic effects are greater than specifications in the technical data. (→ See Kap. 10.) - Pressure is outside permitted range. - Sensor defect. 	<ul style="list-style-type: none"> - Block off electromagnetic effects or eliminate source of disturbance. - Check pressure present, reduce or increase if necessary. - If the pressure is within the permitted range, replace sensor. 	28
728 (A728)	Alarm B	Failure (F)	F>RAM error	<ul style="list-style-type: none"> - Fault in the main electronics. - Main electronics defect. 	<ul style="list-style-type: none"> - Briefly disconnect device from the power supply. - Replace main electronics. 	2

Code	Corresponds to NA 64	Message category NE 107	Message/description	Cause	Measure	Priority
729 (A729)	Alarm B	Failure (F)	F>RAM error	<ul style="list-style-type: none"> - Fault in the main electronics. - Main electronics defect. 	<ul style="list-style-type: none"> - Briefly disconnect device from the power supply. - Replace main electronics. 	3
730 (E730)	Error C Factory setting: Warning	Out of specification (S)	S>LRV user limits exceeded	<ul style="list-style-type: none"> - Pressure measured value has undershot the value specified for the Pmin ALARM WINDOW parameter. - Loose connection at sensor cable 	<ul style="list-style-type: none"> - Check system/pressure measured value. - Change value for Pmin ALARM WINDOW if necessary. (→ See also Operating Instructions BA00296P, parameter description Pmin ALARM WINDOW) - Wait a short period of time and tighten the connection, or avoid loose connection. 	46
731 (E731)	Error C Factory setting: Warning	Out of specification (S)	S>URV user limits exceeded	<ul style="list-style-type: none"> - Pressure measured value has overshoot the value specified for the Pmax ALARM WINDOW parameter. 	<ul style="list-style-type: none"> - Check system/pressure measured value. - Change value for Pmax ALARM WINDOW if necessary. (→ See also Operating Instructions BA00296P, parameter description Pmax ALARM WINDOW). 	45
732 (E732)	Error C Factory setting: Warning	Out of specification (S)	S>LRV Temp. User limits exceeded	<ul style="list-style-type: none"> - Temperature measured value has undershot the value specified for the Tmin ALARM WINDOW parameter. - Loose connection at sensor cable 	<ul style="list-style-type: none"> - Check system/temperature measured value. - Change value for Tmin ALARM WINDOW if necessary. (→ See also Operating Instructions BA00296P, parameter description Tmin ALARM WINDOW). - Wait a short period of time and tighten the connection, or avoid loose connection. 	48
733 (E733)	Error C Factory setting: Warning	Out of specification (S)	S>URV Temp. User limits exceeded	<ul style="list-style-type: none"> - Temperature measured value has overshoot the value specified for the Tmax ALARM WINDOW parameter. 	<ul style="list-style-type: none"> - Check system/temperature measured value. - Change value for Tmax ALARM WINDOW if necessary. (→ See also Operating Instructions BA00296P, parameter description Tmax ALARM WINDOW). 	47
736 (A736)	Alarm B	Failure (F)	F>RAM error	<ul style="list-style-type: none"> - Fault in the main electronics. - Main electronics defect. 	<ul style="list-style-type: none"> - Briefly disconnect device from the power supply. - Replace main electronics. 	4
737 (A737)	Alarm B	Failure (F)	F>Measurement error	<ul style="list-style-type: none"> - Fault in the main electronics. - Main electronics defect. 	<ul style="list-style-type: none"> - Briefly disconnect device from the power supply. - Replace main electronics. 	20
738 (A738)	Alarm B	Failure (F)	F>Measurement error	<ul style="list-style-type: none"> - Fault in the main electronics. - Main electronics defect. 	<ul style="list-style-type: none"> - Briefly disconnect device from the power supply. - Replace main electronics. 	19
739 (A739)	Alarm B	Failure (F)	F>Measurement error	<ul style="list-style-type: none"> - Fault in the main electronics. - Main electronics defect. 	<ul style="list-style-type: none"> - Briefly disconnect device from the power supply. - Replace main electronics. 	23

Code	Corresponds to NA 64	Message category NE 107	Message/description	Cause	Measure	Priority
740 (E740)	Error C Factory setting: Warning	Maintenance required (M)	M>Calculation overflow, bad configuration, hardware defect	<ul style="list-style-type: none"> - Level measuring mode: Level mode* "LIND. MEASURAND.": the measured pressure has undershot the value for HYDR. PRESS. MIN. or overshot the value for HYDR. PRESS. MAX. (*For other level modes: The measured level did not reach the LEVEL MIN value or exceeded the LEVEL MAX value.) - Pressure measuring mode: Main electronics defect. 	<ul style="list-style-type: none"> - Check configuration and carry out calibration again if necessary. - Select a device with a suitable measuring range. - See also Operating Instructions BA00296P, parameter description LEVEL MIN. these Operating Instructions, Page 2. - Replace main electronics. 	27
741 (A741)	Alarm B	Function check (C)	C>TANK HEIGHT out of edit limits	<ul style="list-style-type: none"> - LEVEL MIN or LEVEL MAX has been changed. 	<ul style="list-style-type: none"> - Perform reset (Code 35710) and carry out calibration again. 	43
742 (A742)	Alarm B	Failure (F)	F>Sensor connection error (upload)	<ul style="list-style-type: none"> - Electromagnetic effects are greater than specifications in the technical data. (→ See Kap. 10.) This message normally only appears briefly. - Cable connection sensor –main electronics disconnected. - Sensor defect. 	<ul style="list-style-type: none"> - Wait a few minutes. - Perform reset (Code 35710) and carry out calibration again. - Check cable connection and repair if necessary. - Replace sensor. 	18
743 (A743)	Alarm B	Failure (F)	F>Electronic PCB error during initialization	<ul style="list-style-type: none"> - Electromagnetic effects are greater than specifications in the technical data. (→ See Kap. 10.) This message normally only appears briefly. - Main electronics defect. 	<ul style="list-style-type: none"> - Wait a few minutes. - Restart the device. Perform reset (Code 2506 or 33062). - Replace main electronics. 	14
744 (A744)	Alarm B	Failure (F)	F>Main electronic PCB error	<ul style="list-style-type: none"> - Electromagnetic effects are greater than specifications in the technical data. (→ See Kap. 10.) - Main electronics defect. 	<ul style="list-style-type: none"> - Restart the device. Perform reset (Code 2506 or 33062). - Block off electromagnetic effects or eliminate source of disturbance. - Replace main electronics. 	11
745 (W745)	Warning C	Maintenance required (M)	M>Sensor data unknown	<ul style="list-style-type: none"> - Sensor does not suit the device (electronic sensor nameplate). Device continues measuring. 	<ul style="list-style-type: none"> - Replace sensor with a suitable sensor. 	54
746 (W746)	Warning C	Function check (C)	C>Sensor connection error - initialising	<ul style="list-style-type: none"> - Electromagnetic effects are greater than specifications in the technical data. (→ See Kap. 10.) This message normally only appears briefly. - Overpressure or low pressure present. 	<ul style="list-style-type: none"> - Wait a few minutes. - Restart the device. Perform reset (Code 1 or 40864). - Block off electromagnetic effects or eliminate source of disturbance. - Reduce or increase pressure. 	26
747 (A747)	Alarm B	Failure (F)	F>Sensor software not compatible to electronics	<ul style="list-style-type: none"> - Sensor does not suit the device (electronic sensor nameplate). 	<ul style="list-style-type: none"> - Replace sensor with a suitable sensor. 	16
748 (A748)	Alarm B	Failure (F)	F>Memory failure in signal processor	<ul style="list-style-type: none"> - Electromagnetic effects are greater than specifications in the technical data. (→ See Kap. 10.) - Main electronics defect. 	<ul style="list-style-type: none"> - Block off electromagnetic effects or eliminate source of disturbance. - Replace main electronics. 	15

Code	Corresponds to NA 64	Message category NE 107	Message/description	Cause	Measure	Priority
750 (A750)	Warning C	Function check (C)	C>Configuration not permitted	<ul style="list-style-type: none"> By means of the operation profile, options were selected for the configuration of the device but the options do not suit one another. For example, if the option "1" (linearization table) was selected for LIN_TYPE and the unit "1347 (m³/s)" was selected for PRIMARY_VALUE_UNIT. 	<ul style="list-style-type: none"> Check configuration. Perform reset (Code 1 or 40864) and carry out calibration again. 	44



9.1.1 Onsite display error messages

If the device detects a defect in the onsite display during initialization, the following error messages can be displayed:

Message	Measure
Initialization, VU Electr. Defect A110	Exchange onsite display.
Initialization, VU Electr. Defect A114	
Initialization, VU Electr. Defect A281	
Initialization, VU Checksum Err. A110	
Initialization, VU Checksum Err. A112	
Initialization, VU Checksum Err. A171	

9.2 Response of outputs to errors

The device differentiates between the message types "Alarm", "Warning" and "Error".
→ See the following table and →  69, Kap. 9.1 "Messages".

Output	A (Alarm)	W (Warning)	E (Error: Alarm/Warning)
PROFIBUS	The process variable in question is transmitted with the status Bad.	Device continues measuring. The process variable in question is transmitted with the status Uncertain.	For this error, you can enter whether the device should react as in the event of an alarm or as in the event of a warning. The output status is transmitted accordingly with the status Bad, Uncertain, or GOOD. To configure the status for this error, you can configure the "SELECT ALARM TYPE" parameter (see BA00296P) or the relevant parameter in Fieldcare (menu path: PROFILE VIEW → PHYSICAL BLOCK → PB PARAMETER → PV STATUS CONFIG (→ Kap. 9.2.2)). Note: "GOOD" can only be configured as the status to be output via Fieldcare in the "PV STATUS CONFIG" menu path.
Bar Graph (onsite display)	The bar graph assumes the values specified via the FAILSAFE MODE (FAIL SAFE MODE ¹⁾) and the FAIL SAFE DEFAULT VALUE (FAIL SAFE DEFAULT VALUE ¹⁾) parameters. → See also Kap. 9.2.1.	Device continues measuring.	For this error, you can enter whether the device should react as in the event of an alarm or as in the event of a warning. See corresponding "Alarm" or "Warning" column.
Onsite display	<ul style="list-style-type: none"> - The measured value and message are displayed alternately - Measured value display:  -symbol is permanently displayed. <p>Message display</p> <ul style="list-style-type: none"> - A + 3-digit number such as A122 and - Description 	<ul style="list-style-type: none"> - The measured value and message are displayed alternately - Measured value display:  -symbol flashes. <p>Message display:</p> <ul style="list-style-type: none"> - W + 3-digit number such as W613 and - Description 	<ul style="list-style-type: none"> - The measured value and message are displayed alternately - Measured value display: see corresponding "Alarm" or "Warning" column <p>Message display:</p> <ul style="list-style-type: none"> - E + 3-digit number such as E713 and - Description
Remote operation (FieldCare)	In the case of an alarm, the ALARM STATUS parameter displays a ²⁾ 3-digit number such as 122 for "Sensor connection error, incorrect data."	In the case of a warning, the ALARM STATUS ²⁾ parameter displays a 3-digit number such as 613 for "Simulation is active".	In the case of an error, the ALARM STATUS parameter ²⁾ displays a 3-digit number such as 731 for "Pmax ALARM WINDOW undershot".

- 1) Parameter are displayed via remote operation (e.g. FieldCare) only.
Menu path: PROFILE VIEW → ANALOG INPUT BLOCK → AI PARAMETER → FAIL SAFE MODE
- 2) Menu path onsite display: GROUP SELECTION → OPERATING MENU → DIAGNOSTICS → MESSAGES
Menu path FieldCare: MANUFACTOR VIEW → OPERATING MENU → DIAGNOSTICS → MESSAGES

9.2.1 Analog Input Block

If the Analog Input Block receives an input or simulation value with the status Bad, the Analog Input Block uses the failsafe mode defined in the FAIL SAFE MODE¹ parameter.

The following options are available by means of the FAIL SAFE MODE¹ parameter:

- Last valid OutValue
The last valid value is used for further processing with the status Uncertain.
- FAIL SAFE DEFAULT VALUE
The value specified by means of the FAIL SAFE DEFAULT VALUE¹ parameter is used for further processing with the status Uncertain.
- Status bad
The current value is used for further processing with the status Bad.

Factory setting:

- FAIL SAFE MODE¹: FAIL SAFE DEFAULT VALUE
- FAIL SAFE DEFAULT VALUE¹: 0
- The failsafe mode is also activated if the "Out of Service O/S" option was selected by means of the TARGET_MODE² parameter.
- The FAIL SAFE MODE and FSAVE_VALUE parameter are available via remote operation (e.g. FieldCare) only.

1) Menu path: PROFILE VIEW → ANALOG INPUT BLOCK → AI PARAMETER

2) Menu path: PROFILE VIEW → ANALOG INPUT BLOCK → AI STANDARD PARAMETER

9.2.2 Setting the status of the flexible alarms

The event category can be defined individually for the following events - regardless of the event group to which they are assigned in the default setting:

- **115**: Sensor overpressure
- **120**: Sensor low pressure
- **715**: Sensor over temperature
- **716**: Process isolating diaphragm broken
- **717**: Transmitter over temperature
- **718**: Transmitter under temperature
- **720**: Sensor under temperature
- **726**: Sensor temperature error - overrange
- **727**: Sensor pressure error - overrange
- **730**: LRV user limits exceeded
- **731**: URV user limits exceeded
- **732**: LRV Temp. User limits exceeded
- **733**: URV Temp. User limits exceeded
- **740**: Calculation overflow, bad configuration

To change the measured value status (Bad, Uncertain, Good) assigned to an event, select the desired status from the picklist.

Example

The status "Bad" should be used for error 115 "Sensor overpressure" instead of the status "Uncertain".

1. In the FieldCare navigation window navigate to **PROFILE VIEW → PB Parameter**

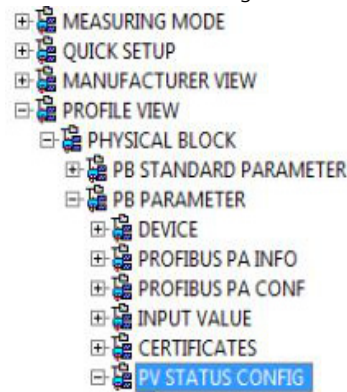

2. In the default setting, all the bits have "Uncertain" for "Status Select Events", apart from 716.

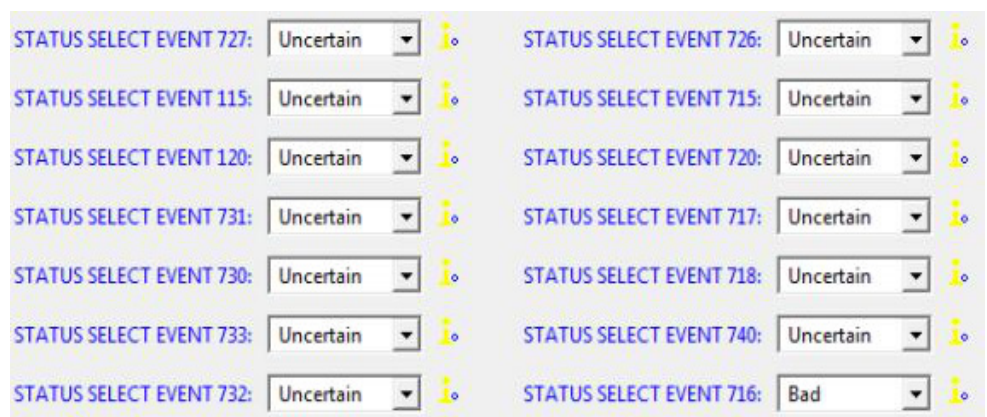

3. Select the "Bad" option for the row "Status Select Event 115". Press the Enter key to confirm.

9.3 Confirming messages

Depending on the settings for the ALARM DISPL. TIME and ACK. ALARM MODE parameters, the following measures should be taken to clear a message:

Settings ¹⁾	Measures
<ul style="list-style-type: none"> - ALARM DISPL. TIME = 0 s - ACK. ALARM MODE = Off 	<ul style="list-style-type: none"> - Rectify cause of the message (see also Kap. 9.1).
<ul style="list-style-type: none"> - ALARM DISPL. TIME > 0 s - ACK. ALARM MODE = Off 	<ul style="list-style-type: none"> - Rectify cause of the message (see also Kap. 9.1). - Wait for the alarm display time to elapse.
<ul style="list-style-type: none"> - ALARM DISPL. TIME = 0 s - ACK. ALARM MODE = On 	<ul style="list-style-type: none"> - Rectify cause of the message (see also Kap. 9.1). - Confirm message using ACK. ALARM parameter.
<ul style="list-style-type: none"> - ALARM DISPL. TIME > 0 s - ACK. ALARM MODE = On 	<ul style="list-style-type: none"> - Rectify cause of the message (see also Kap. 9.1). - Confirm message using ACK. ALARM parameter. - Wait for the alarm display time to elapse. If a message appears and the alarm display time elapses before the message has been acknowledged, the message will be cleared once it has been acknowledged.

1) ALARM DISPL. TIME and ACK. ALARM MODE parameter are located in the MESSAGES menu.

9.4 Repair

The Endress+Hauser repairs concept provides for measuring devices to have a modular design and also the customer may carry out repairs (→  80, "Spare Parts").

- For certified devices, please consult Chapter "Repair of Ex-certified devices".
- For more information on service and spare parts contact the Endress+Hauser Service. (→ See www.endress.com/worldwide)

9.5 Repair of Ex-certified devices

WARNING

Limitation of electrical safety due to incorrect connection!

Risk of explosion!

When repairing Ex-certified devices, please note the following:

- Only specialist personnel or Endress+Hauser may undertake repairs of certified devices.
- Relevant standards, national hazardous area regulations and Safety Instructions (XA...) and Certificates must be observed.
- Only genuine Endress+Hauser spare parts may be used.
- When ordering spare parts, please check the device designation on the nameplate. Identical parts may only be used as replacements.
- Electronic inserts or sensors already in use in a standard instrument may not be used as spare parts for a certified device.
- Carry out repairs according to the instructions. After repairs, the device must fulfil the requirements of the specified individual tests.
- A certified device may only be converted into another certified variant by Endress+Hauser.
- All repairs and modifications must be documented.

9.6 Spare Parts

- Some replaceable measuring device components are identified by means of a spare part nameplate. This contains information about the spare part.
- All the spare parts for the measuring device along with the order code are listed in the W@M Device Viewer (www.endress.com/deviceviewer) and can be ordered. If available, users can also download the associated Installation Instructions.



Measuring device serial number:

- Located on the device and spare part nameplate.
- Can be read out via the "DEVICE SERIAL No" parameter in the "TRANSMITTER DATA" submenu.

9.7 Return

The measuring device must be returned if repairs or a factory calibration are required, or if the wrong measuring device has been ordered or delivered. According to legal regulations, Endress+Hauser, as a ISO-certified company, is required to follow certain procedures when handling returned products that are in contact with process fluids.

To ensure swift, safe and professional device returns, please read the return procedures and conditions on the Endress+Hauser website at www.services.endress.com/return-material.

9.8 Disposal

When disposing, separate and recycle the device components based on the materials.

9.9 Software history

Date	Software version	Changes software	Documentation	
			Operating Instructions	Description of Instrument Functions
05.2007	04.00.zz	Original software. Operated via: – FieldCare Version 2.15.00	BA356P/00/EN/07.07 71043311	BA296P/00/EN/07.07 71043302
			BA356P/00/EN/12.07 71043311	BA296P/00/EN/07.07 71043302
			BA356P/00/EN/05.08 71071718	BA296P/00/EN/05.08 71071861
			BA356P/00/EN/08.08 71077295	BA296P/00/EN/05.08 71071861
			BA356P/00/EN/06.09 71095401	BA296P/00/EN/06.09 71095454
			BA356P/00/EN/05.10 71111760	BA296P/00/EN/05.10 71111811
			BA00356P/00/EN/13.11 71139747	BA00296P/00/EN/13.11 71139803
			BA00356P/00/EN/14.12 71161909	BA00296P/00/EN/13.11 71139803
07.2013	04.01.zz	Profile 3.02 Integration	BA00356P/00/EN/15.13 71220532	BA00296P/00/EN/14.13 71221509
			BA00356P/00/EN/16.14 71254277	BA00296P/00/EN/14.13 71221509
			BA00356P/00/EN/17.14 71270397	BA00296P/00/EN/15.14 71270404
			BA00356P/00/EN/18.16 71336243	BA00296P/00/EN/16.16 71336361

9.10 Hardware history

Date	Hardware version	Changes hardware
05.2005	1.0	Original hardware
06.2007	1.10	Resistance inserted due to new requirements.
04.2008	02.00	Replacement of IC Media Access Unit

10 Technical data

For technical data, please refer to the Technical Information TI00416P for Deltapilot S.

Index

A

Acyclic data exchange	39
Alarm messages	69

C

Cable specification	22
Configuring the device address	30
Current consumption	22
Cyclic data diagram	36
Cyclic data exchange	34

D

Data format	46
Deltapilot S block model	34
Designated use	8
Display	23

E

Electrical connection	20
Error messages	69

F

Factory setting	54
FieldCare	50

G

General structure of the operating menu	47
Grounding	22
GSD (Device Master File)	32

H

Hazardous area	9
HistoROM/M-DAT	50

I

Incoming acceptance	13
Input data, Structure	36

L

Language, selection	57
Level measurement	60
Level measurement, Quick Setup menu	62
Locking operation	53

M

Measuring mode, selection	57
---------------------------------	----

N

Nameplate	10
Number of devices	27

O

Onsite display	23
Operating elements, function	25–26
Operating elements, position	24
Operating keys, onsite, function	25–26
Operating keys, position	24
Operational safety	8

Output data, Structure	36
Overvoltage protection	22

P

Pipe mounting	16
Position adjustment, onsite	25
Position adjustment, onsite, FieldCare	59
Pressure measurement	64
Pressure measurement, Quick Setup menu	64
Product safety	9

Q

Quick Setup menu level	62
Quick Setup menu pressure	64

R

Repair	80
Repair of Ex-certified devices	80
Reset	54
Returning devices	80
Rotating the housing	18

S

Scaling the OUT value	66
Scope of delivery	12
Separate housing, assemble and mount	17
Shielding	22
Sicherheitshinweise	8
Slot/index tables	40
Software history	81
Spare Parts	80
Status code	37
Storage	13
Supply voltage	21
System architecture PROFIBUS PA	27
System integration	32
System units (SET UNIT TO BUS)	67

T

Troubleshooting	69
-----------------------	----

U

Unlocking operation	53
---------------------------	----

W

Wall mounting	16
Warnings	69
Workplace safety	8



www.addresses.endress.com
