

# **FKC - Differential Pressure (flow) Transmitter for High Static Pressure**

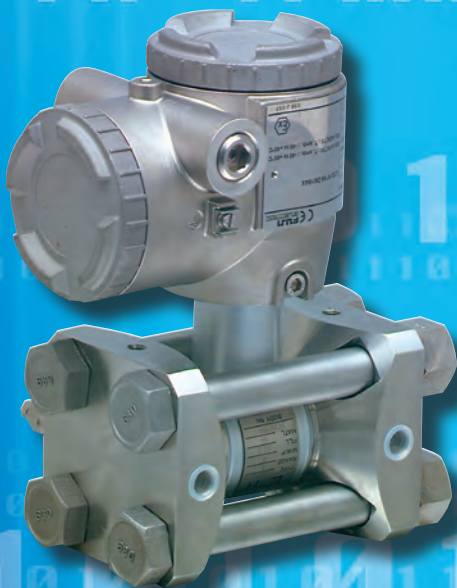
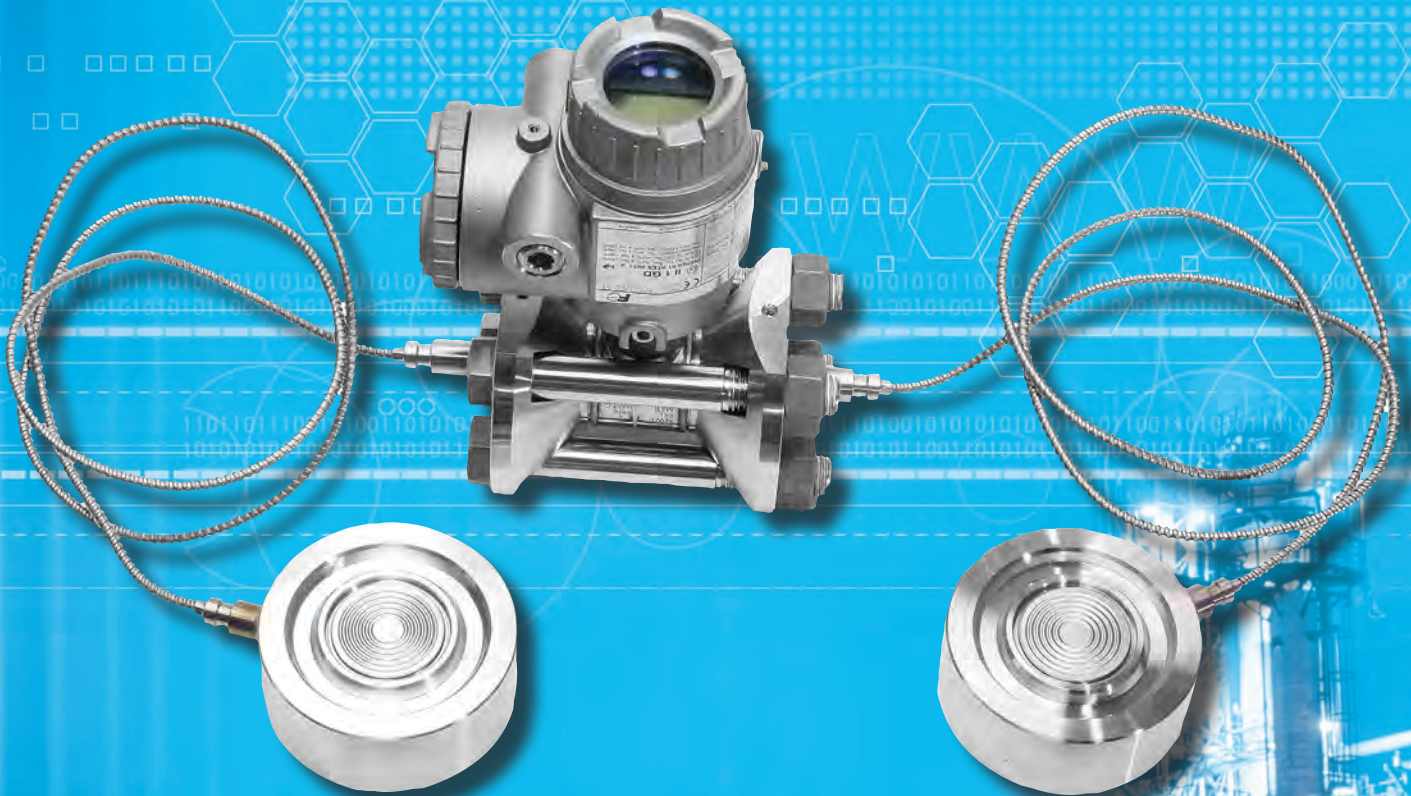

## Solutions for specific customer applications :

Based on extensive experience of supplying transmitters for Oil & Gas applications, Fuji Electric France, is proud to announce the release of its latest Differential Pressure as a direct response to our customer's requirement in high pressure applications that are traditionally found in Oil & Gas flow measurement. The experience and technical capability that we built into the new transmitter enables it to measure differential pressures of 130 mbar at static pressures of up to 15 000 Psi (1035 bar), typically found in top side and subsea applications.

## Measuring principle :

The transmitter utilizes a unique micromachined capacitive silicon sensor with state of the art microprocessor technology to provide exceptional performance and functionality. The silicon sensor is assembled floating in measuring cell neck, which allows extreme high line pressures and improves the static pressure characteristics.

## Robust construction :

The design is based on an all welded construction, where the welded assembling of the process covers on the measuring cell replaces the gaskets. Adapted SS 660 bolting and the specific process covers – NACE compatible – ensure that the required mechanical strength to the assembly is certified according to a PED category IV module H1.

## Performance specifications

<b>Accuracy rating :</b> (including linearity, hysteresis and repeatability)	For spans greater than 1/10 of URL : $\pm 0.1\%$ of span at reference conditions = 22°C $\pm 3^\circ\text{C}$ and atmospheric pressure
<b>Stability</b>	$\pm 0.2\%$ of upper range limit (URL) for 3 years (at reference conditions = 22°C $\pm 3^\circ\text{C}$ and atmospheric pressure)
<b>Ambient temperature effect</b>	Zero : $\pm (0.1 + 0.025 \times \text{URL} / \text{span})$ in % of URL / 28°C Total : $\pm (0.125 + 0.025 \times \text{URL} / \text{span})$ in % of URL / 28°C Double the effects for diaphragm material code "H" (7th digit in codes symbols)
<b>Static pressure effect</b>	<b>Standard specifications :</b> Zero : $\pm 0.1\%$ of URL / 10 MPa Hysteresis & repeatability of zero : any value inside the envelop of $\pm 0,1\%$ of URL/10 MPa Span : 0 to - 0.3% of span / 10 MPa Double the effects for diaphragm material code "H" (7th digit in codes symbols) <b>Premium specifications :</b> Zero : $\pm 0.1\%$ of URL / 10 MPa Hysteresis & repeatability of zero : $\pm 0,1\%$ of URL Max zero change = $\pm 0,15\%$ URL over steps of 10 MPa (curve shape for zero versus static pressure)
<b>Supply voltage effect</b>	Less than 0.05% of calibrated span per 10 V
<b>RFI effect</b>	Less than 0.2% of URL for the frequencies of 20 to 1000 MHz and field strength 30 V/m when electronics covers in place. (Classification : 2-abc : 0.2% span per SAMA PMC 33.1)
<b>Mounting position effect</b>	Zero shift : Less than 0.12 kPa {1.2 mbar} for a 10° tilt in any plane. No effect on span. This error can be corrected by adjusting Zero after installation.
<b>Vibration effect</b>	$< \pm 0,25\%$ of spans for spans greater than 1/10 of URL. Frequency 10 to 150 Hz, acceleration 39,2 m/sec <sup>2</sup>
<b>Dielectric strength</b>	500 V AC, 50/60 Hz 1 min, between circuit and earth.
<b>Insulation resistance</b>	More than 100 MΩ at 500 V DC
<b>Turn-on time</b>	4 seconds

## Specifications in case of square root output

<b>Accuracy rating</b>	<b>Output</b> 50 to 100% : $\pm 0,1\%$ of span 20 to 50% : $\pm 0,25\%$ of span 10 to 20% : $\pm 0,5\%$ of span
<b>Ambient temperature effect</b>	Shift at 20% output point : $\pm (0,3 + 0,25 \times \text{URL} / \text{span})$ in % of URL / 28°C
<b>Low flow cut-off</b>	Customer configurable for any point between 0 to 20% of output.

## Physical Specifications

<b>Process connections</b>	1/4" NPT, autoclave 9/16 - 18 UNF - 2B, others upon request.
<b>Wetted parts materials</b>	Diaphragm SS 316L, Hast.C 276, Other wetted parts material : SS 316L, Hast.C 276, Duplex, Inconel 625
<b>Non wetted parts</b>	Electronics housing : SS 316 Bolts / nuts : ASTM-A453 Grad 660
<b>Ambient temperature</b>	-10 to 85°C
<b>Process temperature</b>	-10 to 120 °C
<b>Remote seal designs</b>	To avoid hydrate formation for subsea applications, remote seals can be assembled on the DP transmitter. Possible process connections via remote seals according API, RTJ standards or according customer design.

## Code Symbols

1	2	3	4	5	6	7	8	9	10	11	12	13	14	15	16	
F	K	C					4	-		C			-	W	W	<b>DESCRIPTION</b>
F	D	C														Smart, 4-20 mAdc + Fuji/Hart™ digital signal Bus communication (RS 485 Modbus™)
																<b>Electrical connection</b>
			T													1/2 - 14 NPT
			W													M 20 x 1,5
				W												<b>Max working pressure (static pressure) Test pressure</b>
				S												575 bar 860 bar (12 474 Psi)
				T												690 bar 1030 bar (14 939 Psi)
				U												860 bar 1285 bar (18 638 Psi)
																1035 bar 1545 bar (22 408 Psi)
																<b>Range (mbar)</b>
			3													Min Max
																0 - 130 0 - 320
			5													0 - 130 0 - 1300
			6													0 - 500 0 - 5000
			8													0 - 3000 0 - 30000
				V												<b>Wetted parts material</b>
				H												All wetted parts in SS 316L
																Measuring cell wetted parts in Hast C 276 - process cover in SS316L
																<b>Indicator Arrester Communication type</b>
			4	-	A											No No 4/20 mA - Hart™
			4	-	L											LCD, 0-100% No 4/20 mA - Hart™
			4	-	P											LCD, Custom scale No 4/20 mA - Hart™
			4	-	S											LCD, Custom scale Yes 4/20 mA - Hart™
			4	-	U											No Yes Modbus RS 485
																<b>Approvals for hazardous locations (consult FUJI for availability)</b>
				A												None (standard)
				X												Flameproof housing ATEX ExII 2 GD - EEx d IIC T5/T6
				K												Intrinsic Safety ATEX ExII 1 GD - EEx ia IIC T4/T5
				D												FM - Flameproof housing Class I, Division 1, Group B,C,D Dust ignitionproof Class II/III, Division 1, Group E,F,G - (elec. conn. code "T" only)
				H												FM - Intrinsic safety Class I, II, III, Division 1, Group A,B,C,D,E,F,G Non incentive Class I,II,III, Division 2, Group A,B,C,D,F,G
				M												Combined ATEX ExII 2 GD - EEx d IIC T5/T6 & ATEX ExII 1 GD - EEx ia IIC T4/T5
																<b>Mounting bracket (SS)</b>
																<b>Tag plate Electronics housing</b>
				C												Without SS 316
				E												SS 316L SS 316
																<b>Fill fluid</b>
				M												Specific oil fill for cell
				P												Specific oil fill for cell. Wetted parts and bolting in conformity with NACE
																Welded process cover design
																Process cover bolts/nuts in ASTM A 453 grade 660
																<b>Process connection</b>
																A 1/4 NPT
																B 1/2 NPT (not recommended for high static pressure)
																C 13/16 - 16 UNF - 2B / SF562CX20
																D 9/16 - 18 UNF - 2B / F250C
																E 9/16 - 18 UNF - 2B / SF375CX20
																F 3/8 - 24 UNF - 2B / Speedbite SW 125
																G 7/16 - 20 UNF - 2B / SF250CX20

## Outline dimensions

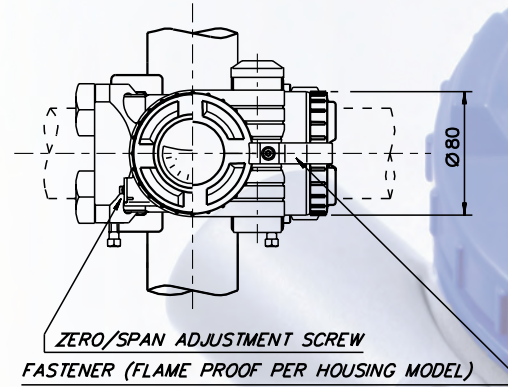
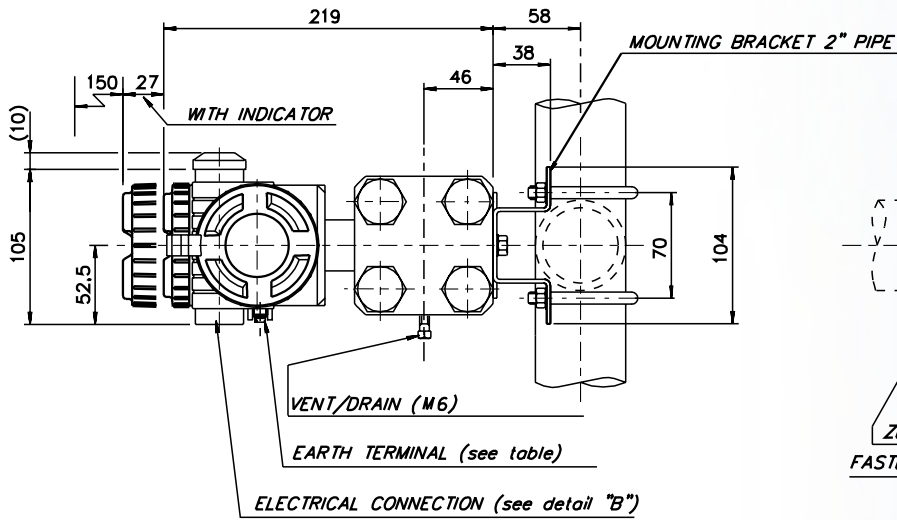

### PROCESS CONNECTIONS

13/16-16 UNF - 2B SF562 CX20 - for 9/16 MP AUTOCLAVE CONNECTIONS

9/16-18 UNF - 2B F 250C - for 1/4 HP AUTOCLAVE CONNECTIONS

9/16-18 UNF - 2B SF 375 CX20 - for 3/8 MP AUTOCLAVE CONNECTIONS

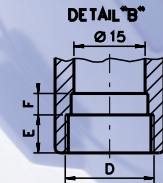
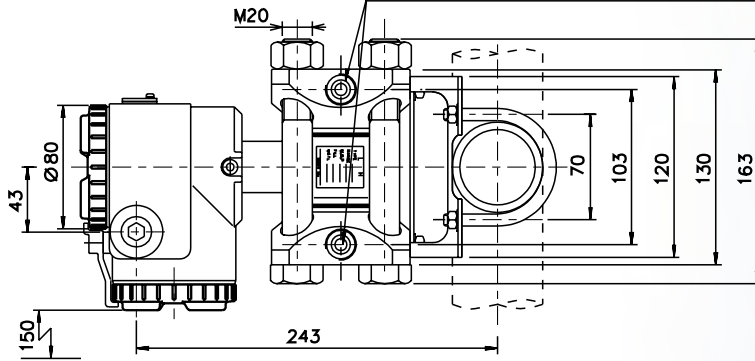

TABLE

CONDUIT CONN.			EARTH TERMINAL
D	E	F	
1/2-14NPT	16	5	N°8 - 32UNC
M20x1.5	16	5	M4



## Fuji Electric France S.A.S.

46 rue Georges Besse - Z.I du Brézet

63039 Clermont Ferrand cedex 2 - FRANCE

Tel. +33 4 73 98 26 98 - Fax +33 4 73 98 26 99

E-mail : sales.dpt@fujielectric.fr - Web : www.fujielectric.fr

Fuji Electric can accept no responsibility for possible errors in catalogues, brochures or other printed material. Fuji Electric reserves the right to alter its products without notice. This also applies to products already on order provided that such alterations can be made without subsequential changes being necessary in specifications already agreed. All trademarks in this material are property of the respective companies. All rights reserved.