



**FLOWRATE INDICATOR / TOTALIZER**

MS476
0615
0014

# ***Electronic Register (ERA)***

**METER MOUNT**

**REMOTE MOUNT**



**ERA-M  
GA110P**

**ERA-RMA  
ERA-RMP  
GB110P**

**Signal input flowmeter: NPN and Reed  
Signal outputs: (0)4-20mA ref. flowrate and pulse ref. total**





## SAFETY INSTRUCTIONS

- **Any responsibility is lapsed if the instructions and procedures as described in this manual are not followed.**
- **LIFE SUPPORT APPLICATIONS: The ERA is not designed for use in life support appliances, devices, or systems where malfunction of the product can reasonably be expected to result in a personal injury. Customers using or selling these products for use in such applications do so at their own risk and agree to fully indemnify the manufacturer and supplier for any damages resulting from such improper use or sale.**
- **Electro static discharge does inflict irreparable damage to electronics! Before installing or opening the unit, the installer has to discharge himself by touching a well-grounded object.**
- **This unit must be installed in accordance with the EMC guidelines (Electro Magnetic Compatibility).**
- **Do connect a proper grounding to the aluminum casing as indicated.**

## DISPOSAL - WEEE DIRECTIVE



- The WEEE Directive requires the recycling of waste electrical and electronic equipment in the European Union.
- Whilst the WEEE Directive does not apply to some of Macnaught's products, we support its policy and ask you to be aware of how to dispose of this product.
- The crossed out wheelee bin symbol illustrated and found on our products signifies that this product should not be disposed of in general waste or landfill.
- Please contact your local dealer national distributor or Macnaught Technical Services for information on product disposal..

## SAFETY RULES AND PRECAUTIONARY MEASURES

- The manufacturer accepts no responsibility whatsoever if the following safety rules and precautions instructions and the procedures as described in this manual are not followed.
- Modifications of the ERA implemented without preceding written consent from the manufacturer, will result in the immediate termination of product liability and warranty period.
- Installation, use, maintenance and servicing of this equipment must be carried out by authorized technicians.
- Check the mains voltage and information on the manufacturer's plate before installing the unit.
- Check all connections, settings and technical specifications of the various peripheral devices with the ERA supplied.
- Open the casing only if all leads are free of potential.
- Never touch the electronic components (ESD sensitivity).
- Never expose the system to heavier conditions than allowed according to the casing classification (see manufacture's plate and chapter 4.2.).
- If the operator detects errors or dangers, or disagrees with the safety precautions taken, then inform the owner or principal responsible.
- The local labor and safety laws and regulations must be adhered to.

## ABOUT THE OPERATION MANUAL

This operation manual is divided into two main sections:

- The daily use of the unit is described in chapter 2 "Operation". These instructions are meant for users.
- The following chapters and appendices are exclusively meant for electricians/technicians. These provide a detailed description of all software settings and hardware installation guidance.

This operation manual describes the standard unit as well as most of the options available. For additional information, please contact your supplier.

**A hazardous situation may occur if the ERA is not used for the purpose it was designed for or is used incorrectly. Please carefully note the information in this operating manual indicated by the pictograms:**



A "**warning**" indicates actions or procedures which, if not performed correctly, may lead to personal injury, a safety hazard or damage of the ERA or connected instruments.



Caution !

A "**caution**" indicates actions or procedures which, if not performed correctly, may lead to personal injury or incorrect functioning of the ERA or connected instruments.



Note !

A "**note**" indicates actions or procedures which, if not performed correctly, may indirectly affect operation or may lead to an instrument response which is not planned.

Hardware version:	03.01.xx
Software version:	03.01.xx
Manual :	MS476_0615_0014
© Copyright 2015	Macnaught Pty Ltd – All rights reserved

**Information in this manual is subject to change without prior notice. The manufacturer is not responsible for mistakes in this material or for incidental damage caused as a direct or indirect result of the delivery, performance or use of this material.**

**© All rights reserved. No parts of this publication may be reproduced or used in any form or by any means without written permission of your supplier.**

# CONTENTS MANUAL

Safety instructions .....	2
Disposal - WEEE Directive .....	2
Safety rules and precautionary measures .....	2
About the operation manual .....	3
Contents manual.....	4
1. Introduction.....	5
1.1. System description of the ERA .....	5
2. Operational.....	7
2.1. General .....	7
2.2. Control panel.....	7
2.3. Operator information and functions .....	8
3. Configuration .....	9
3.1. Introduction .....	9
3.2. Programming SETUP-level.....	9
3.2.1. General .....	9
3.2.2. Overview functions SETUP level .....	12
3.2.3. Explanation OF SETUP-functions .....	13
1 - Total.....	13
2 - Flowrate .....	14
3 - Display .....	15
4 – Power Management.....	15
5 - Flowmeter .....	15
6 - Analog output.....	16
6 - Analog output (continued) .....	17
7 - IMPULSE .....	17
8 - Others .....	18
4. Installation .....	19
4.1. General directions.....	19
4.2. Installation / surrounding conditions .....	19
4.3. Dimensions- Enclosure .....	20
4.4. Installing the hardware.....	22
4.4.1. Introduction .....	22
4.4.2. Voltage selection sensor supply .....	23
4.4.3. Terminal connectors .....	24
5. Maintenance.....	27
5.1. General directions.....	27
6.2. Repair .....	27
Appendix A: Technical specification .....	28
Appendix B: Problem solving.....	30
Index of this manual.....	31
List of figures in this manual .....	31

# 1. INTRODUCTION

## 1.1. SYSTEM DESCRIPTION OF THE ERA

### Functions and features

The flowrate / totalizer model ERA is a microprocessor driven instrument designed to display flowrate, total and accumulated total.

This product has been designed with a focus on:

- ultra-low power consumption to allow long-life battery powered applications,
- several mounting possibilities with aluminum or GRP enclosures for harsh industrial surroundings,
- ability to process all types of flowmeter signals,
- transmitting possibilities with analog / pulse outputs.

### Flowmeter input

This manual describes the unit with a pulse type input from the flowmeter "-P version". One flowmeter with a NPN or Reed switch output can be connected to the ERA. To power the sensor, several options are available.

### Standard outputs

- Configurable pulse output: a scaled pulse mirroring a certain totalized quantity. Maximum frequency 60Hz.; the pulse length can be set from 7,8msec up to 2 seconds.
- Configurable linear (0)4-20mA analog output with 10-bits resolution mirroring the actual flowrate. Flowrate levels as well as the minimum and maximum signal output can be tuned.

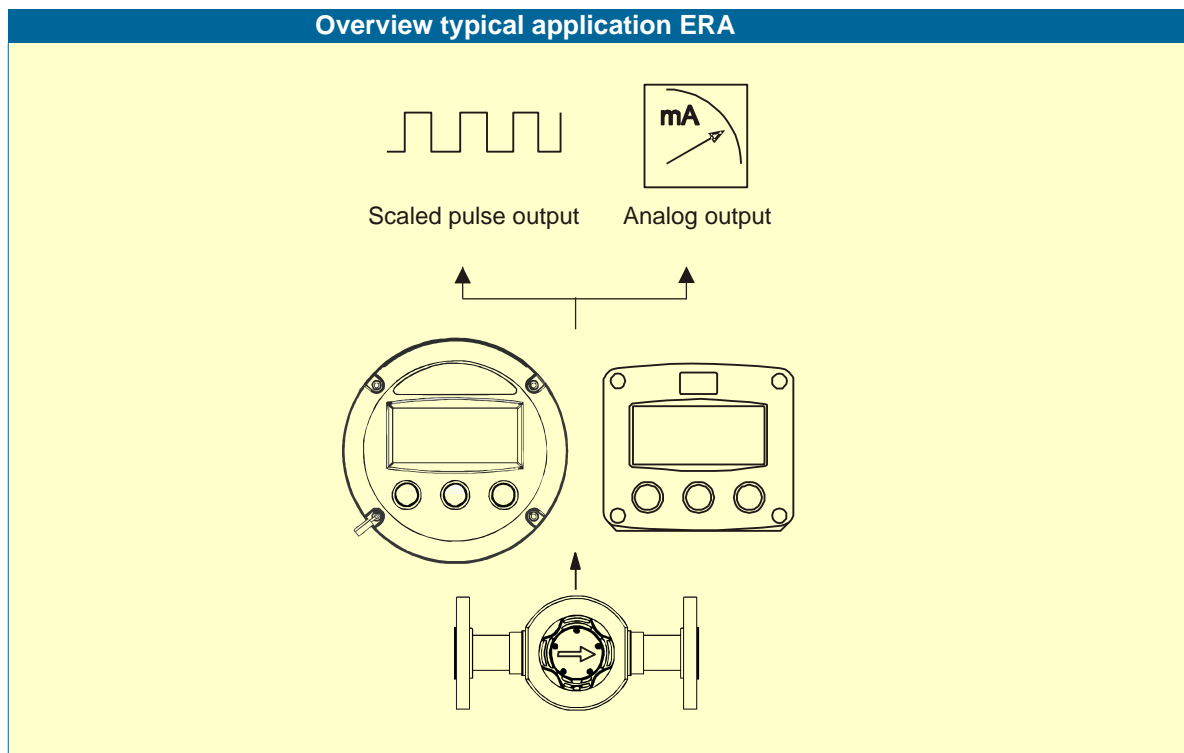

Fig. 1: Typical application for the ERA.

**Configuration of the unit**

The ERA was designed to be implemented in many types of applications. For that reason, a SETUP-level is available to configure your ERA according to your specific requirements.

SETUP includes several important features, such as K-factors, measurement units, signal selection etc. All settings are stored in EEPROM memory and will not be lost in the event of power failure or a drained battery.

To extend the battery-life time (option), please make use of the power-management functions as described in chapter 3.2.3.

**Display information**

The unit has a large transfective LCD with all kinds of symbols and digits to display measuring units, status information, trend-indication and key-word messages.

Flowrate and totals can be displayed either with the small 8mm digits or with the 17mm digits.

A backup of the total and accumulated total in EEPROM memory is made every minute.

## 2. OPERATIONAL

### 2.1. GENERAL



- The ERA may only be operated by personnel who are authorized and trained by the operator of the facility. All instructions in this manual are to be observed.
- Take careful notice of the " Safety rules, instructions and precautionary measures " in the front of this manual.

This chapter describes the daily use of the ERA. This instruction is meant for users / operators.

### 2.2. CONTROL PANEL

The following keys are available:

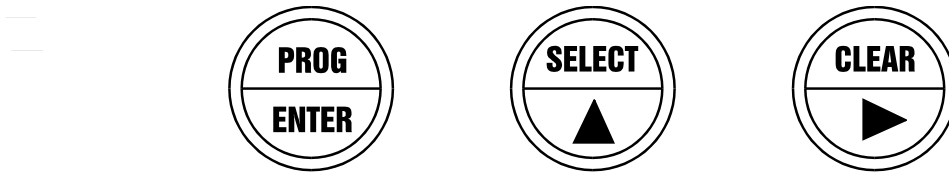

Fig. 2: Control Panel.

#### Functions of the keys



This key is used to program and save new values or settings.  
It is also used to gain access to SETUP-level; please read chapter 3.



This key is used to SELECT accumulated total.  
The arrow-key ▲ is used to increase a value after PROG has been pressed or to configure the unit; please read chapter 3.



Press this key twice to CLEAR the value for total.  
The arrow-key ► is used to select a digit after PROG has been pressed or to configure the unit; please read chapter 3.

### 2.3. OPERATOR INFORMATION AND FUNCTIONS

In general, the ERA will always act at Operator level. The information displayed is dependant upon the SETUP-settings. All pulses generated by the connected flowmeter are measured by the ERA in the background, whichever screen refresh rate setting is chosen. After pressing a key, the display will be updated very quickly during a 30 second period, after which it will slow-down again.



Fig. 3: Example of display information during process.

For the Operator, the following functions are available:

- **Display flowrate / total or flowrate**  
This is the main display information of the ERA. After selecting any other information, it will always return to this main display automatically.  
Total is displayed on the upper-line of the display and flowrate on the bottom line.  
It is possible to display flowrate only with the large 17mm digits; in this instance press the SELECT-key to read the total.  
When "-----" is shown, then the flowrate value is too high to be displayed. The arrows  $\blacklozenge$  indicate the increase/decrease of the flowrate trend.
- **Clear total**  
The value for total can be re-initialized. To do so, press CLEAR twice. After pressing CLEAR once, the flashing text "PUSH CLEAR" is displayed. To avoid re-initialization at this stage, press another key than CLEAR or wait for 20 seconds.  
Re-initialization of total DOES NOT influence the accumulated total.
- **Display accumulated total**  
When the SELECT-key is pressed, total and accumulated total are displayed. The accumulated total cannot be re-initialized. The value will count up to 99,999,999,999. The unit and number of decimals are displayed according to the configuration settings for total.
- **Low-battery alarm**  
When the battery voltage drops, it must be replaced. At first "low-battery" will flash, but as soon as it is displayed continuously, the battery MUST be replaced shortly after!  
Only original batteries supplied by the manufacturer may be used, else the guarantee and liability will be terminated. The remaining lifetime after the first moment of indication is generally several days up to some weeks.



Fig. 4: Example of low-battery alarm.

- **Alarm 01-03**  
When "alarm" is displayed, please consult Appendix B: problem solving.



## 3. CONFIGURATION

### 3.1. INTRODUCTION

This and the following chapters are exclusively meant for electricians and non-operators. In these, an extensive description of all software settings and hardware connections are provided.



Caution !

- Mounting, electrical installation, start-up and maintenance of the instrument may only be carried out by trained personnel authorized by the operator of the facility. Personnel must read and understand this Operating Manual before carrying out its instructions.
- The ERA may only be operated by personnel who are authorized and trained by the operator of the facility. All instructions in this manual are to be observed.
- Ensure that the measuring system is correctly wired up according to the wiring diagrams. The housing may only be opened by trained personnel.
- Take careful notice of the " Safety rules, instructions and precautionary measures " in the front of this manual.

### 3.2. PROGRAMMING SETUP-LEVEL

#### 3.2.1. GENERAL

Configuration of the ERA is done at SETUP-level. SETUP-level is reached by pressing the PROG/ENTER key for 7 seconds; at which time, both arrows  $\blacktriangleleft$  will be displayed. In order to return to the operator level, PROG will have to be pressed for three seconds. Alternatively, if no keys are pressed for 2 minutes, the unit will exit SETUP automatically. SETUP can be reached at all times while the ERA remains fully operational.



Note !

**Note:** A password may be required to enter SETUP. Without this password access to SETUP is denied.

To enter SETUP-level:

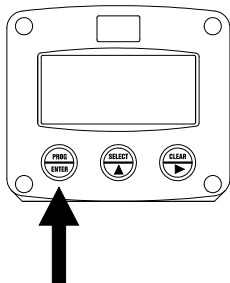

Press  for 7 seconds

Matrix structure SETUP-level:

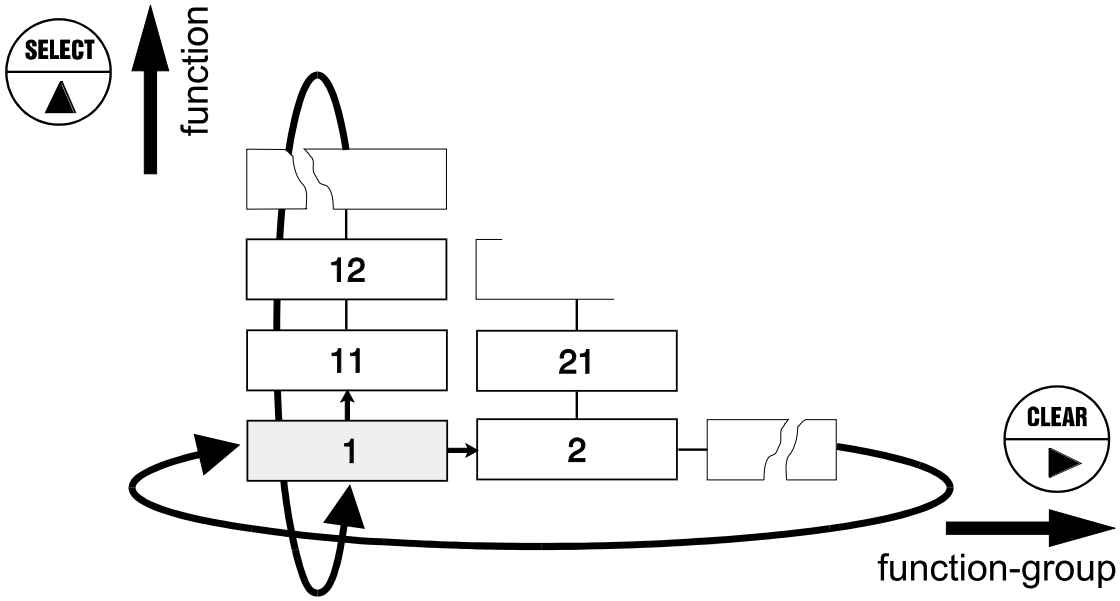

SCROLLING THROUGH SETUP-LEVEL

Selection of function-group and function:

SETUP is divided into several function groups and functions.

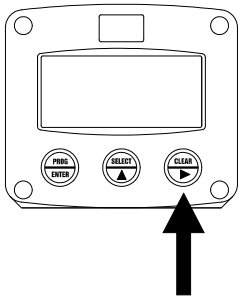

Select function-group with

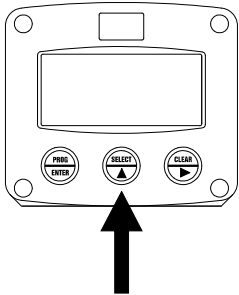

Select function with





Each function has a unique number, which is displayed below the word "SETUP" at the bottom of the display. The number is a combination of two figures. The first figure indicates the function-group and the second figure the sub-function. Additionally, each function is expressed with a keyword.

After selecting a sub-function, the next main function is selected by scrolling through all "active" sub-functions (e.g. 1<sup>▲</sup>, 11<sup>▲</sup>, 12<sup>▲</sup>, 13<sup>▲</sup>, 14<sup>▲</sup>, 1<sup>▶</sup>, 2<sup>▶</sup>, 3<sup>▲</sup>, 31 etc.).

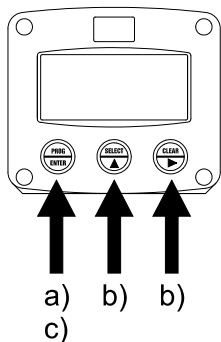

To change or select a value:







a) press  briefly; **PROGRAM** will start flash

b) select or enter value with  and / or 

c) press  to confirm the value / selection.

To change a value, use  to select the digits and  to increase that value.

To select a setting, both  and  can be used.

If the new value is invalid, the increase sign  or decrease-sign  will be displayed while you are programming.

When data is altered but ENTER is not pressed, then the alteration can still be cancelled by waiting for 20 seconds or by pressing ENTER for three seconds: the PROG-procedure will be left automatically and the former value reinstated.



Note !

**Note:** alterations will only be set after ENTER has been pressed!

To return to OPERATOR-level:

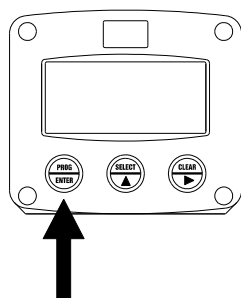

Press  for 3 seconds

In order to return to the operator level, PROG will have to be pressed for three seconds. Also, when no keys are pressed for 2 minutes, SETUP will be left automatically.

## 3.2.2. OVERVIEW FUNCTIONS SETUP LEVEL

<b>SETUP FUNCTIONS AND VARIABLES</b>			
<b>1</b>	<b>TOTAL</b>		
11	UNIT	L - m3 - kg - lb - GAL - USGAL - bbl - no unit	
12	DECIMALS	0 - 1 - 2 - 3 (Ref: displayed value)	
13	K-FACTOR:	0.000010 - 9,999,999	
14	DECIMALS K-FACTOR	0 - 6	
<b>2</b>	<b>FLOWRATE</b>		
21	UNIT	mL - L - m3 - mg - g - kg - ton - GAL - bbl - lb - cf - REV - no unit - scf - Nm3 - NL - P	
22	TIME UNIT	sec - min - hour - day	
23	DECIMALS	0 - 1 - 2 - 3 (Ref: displayed value)	
24	K-FACTOR	0.000010 - 9,999,999	
25	DECIMALS K-FACTOR	0 - 6	
26	CALCULATION	per 1 - 255 pulses	
27	CUT-OFF	0.1 - 999.9 seconds	
<b>3</b>	<b>DISPLAY</b>		
31	FUNCTION	total - flowrate	
32	LIGHT	(OFF) 0% - 20% - 40% - 60% - 80% - 100% (FULL BRIGHTNESS)	
<b>4</b>	<b>POWER MANAGEMENT</b>		
41	LCD NEW	fast - 1 sec - 3 sec - 15 sec - 30 sec - off	
42	BATTERY MODE	operational - shelf	
<b>5</b>	<b>FLOWMETER</b>		
51	SIGNAL	npn - npn_lp - reed - reed_lp	
<b>6</b>	<b>ANALOG</b>		
61	OUTPUT	disable - enable	
62	MINIMUM SIGNAL	0000.000 - 9,999,999 unit/time unit	
63	MAXIMUM SIGNAL	0000.000 - 9,999,999 unit/time unit	
64	CUT-OFF	0.0 - 9.9%	
65	TUNE MIN - (0)4mA	0 - 9,999	
66	TUNE MAX- 20mA	0 - 9,999	
67	FILTER	00 - 99	
<b>7</b>	<b>IMPULSE</b>		
71	WIDTH	0 - 255	
72	DECIMALS	0 - 1 - 2 - 3	
73	AMOUNT	X,XXX,XXX quantity	
<b>8</b>	<b>COMMUNICATION</b>		
81	SPEED	1200 - 2400 - 4800 - 9600	
82	ADDRESS	1 - 255	
83	MODE	ASCII - BUS-RTU - off	
<b>9</b>	<b>OTHERS</b>		
91	TYPE / MODEL	GB110P	
92	SOFTWARE VERSION	03.03.xx	
93	SERIAL NO.	xxxxxxx	
94	PASSWORD	0000 - 9999	
95	TAGNUMBER	0000000 - 9999999	

## 3.2.3. EXPLANATION OF SETUP-FUNCTIONS

<b>1 - TOTAL</b>	
<b>UNIT 11</b>	<p>SETUP - 11 determines the measurement unit for total, accumulated total and pulse output. The following units can be selected:</p> <p style="text-align: center;">L - m3 - kg - lb. - GAL - USGAL - bbl - _ (no unit).</p> <p>Alteration of the measurement unit will have consequences for operator and SETUP-level values. Please note that the K-factor has to be adapted as well; the calculation is not done automatically.</p>
<b>DECIMALS 12</b>	<p>The decimal point determines for total, accumulated total and pulse output the number of digits following the decimal point. The following can be selected:</p> <p style="text-align: center;">0000000 - 111111.1 - 22222.22 - 3333.333</p>
<b>K-FACTOR 13</b>	<p>With the K-factor, the flowmeter pulse signals are converted to a quantity. The K-factor is based on the number of pulses generated by the flowmeter per selected measurement unit (SETUP 11), for example per cubic meter. The more accurate the K-factor, the more accurate the functioning of the system will be.</p> <p><b>Example 1: Calculating the K-factor.</b> <i>Let us assume that the flowmeter generates 2.4813 pulses per liter and the selected unit is "cubic meters / m3". A cubic meter consists of 1000 parts of one liter which implies 2,481.3 pulses per m3. So, the K-factor is 2,481.3. Enter for SETUP - 13: "2481300" and for SETUP - 14 - decimals K-factor "3".</i></p> <p><b>Example 2: Calculating the K-factor.</b> <i>Let us assume that the flowmeter generates 6.5231 pulses per gallon and the selected measurement unit is gallons. So, the K-Factor is 6.5231. Enter for SETUP - 13: "6523100" and for SETUP - 14 decimals K-factor "6".</i></p>
<b>DECIMALS K-FACTOR 14</b>	<p>This setting determines the number of decimals for the K-factor entered. (SETUP 13). The following can be selected:</p> <p style="text-align: center;">0 - 1 - 2 - 3 - 4 - 5 - 6</p> <p>Please note that this setting influences the accuracy of the K-factor indirectly. (i.e. the position of the decimal point and thus the value given) This setting has NO influence on the displayed number of digits for total (SETUP 12)!</p>

## 2 - FLOWRATE

The settings for total and flowrate are entirely separate. In this way, different units of measurement can be used for each e.g. cubic meters for total and liters for flowrate.

The display update time for flowrate is one second or more.

**Note:** these settings also influence the analog output.

<b>UNIT</b> <b>21</b>	<p>SETUP - 21 determines the measurement unit for flowrate. The following units can be selected:</p> <p style="text-align: center;">mL - L - m3 - mg - g - kg - ton - GAL - bbl - lb - cf - REV - no unit - scf - Nm3 - NL - P.</p> <p>Alteration of the measurement unit will have consequences for operator and SETUP-level values. Please note that the K-factor has to be adapted as well; the calculation is not done automatically.</p>
<b>TIME UNIT</b> <b>22</b>	The flowrate can be calculated per second (SEC), minute (MIN), hour (HR) or day (DAY).
<b>DECIMALS</b> <b>23</b>	<p>This setting determines for flowrate the number of digits following the decimal point. The following can be selected:</p> <p style="text-align: center;">00000 - 1111.1 - 2222.22 - 3333.333</p>
<b>K-FACTOR</b> <b>24</b>	<p>With the K-factor, the flowmeter pulse signals are converted to a flowrate. The K-factor is based on the number of pulses generated by the flowmeter per selected measurement unit (SETUP 21), for example per liter. The more accurate the K-factor, the more accurate the functioning of the system will be. For examples read SETUP 13.</p>
<b>DECIMALS K-FACTOR</b> <b>25</b>	<p>This setting determines the number of decimals for the K-factor (SETUP 24). The following can be selected:</p> <p style="text-align: center;">0 - 1 - 2 - 3 - 4 - 5 - 6</p> <p>Please note that this SETUP - influences the accuracy of the K-factor indirectly. This setting has NO influence on the displayed number of digits for "flowrate" (SETUP 23)!</p>
<b>CALCULAT</b> <b>26</b>	<p>The flowrate is calculated by measuring the time between a number of pulses, for example 10 pulses. The more pulses the more accurate the flowrate will be. The maximum value is 255 pulses.</p> <p><b>Note:</b> this setting does influence the update time for the analog output directly (maximum update 10 times a second). If the output response is too slow, decrease the number of pulses.</p> <p><b>Note:</b> the lower the number of pulses, the higher the power consumption of the unit will be (important for battery powered applications).</p> <p><b>Note:</b> for low frequency applications (below 10Hz): do not program more than 10 pulses else the update time will be very slow.</p> <p><b>Note:</b> for high frequency application (above 1kHz) do program a value of 50 or more pulses.</p>
<b>CUT-OFF TIME</b> <b>27</b>	<p>With this setting, you determine a minimum flow requirement thresh-hold, if during this time less than XXX-pulses (SETUP 26) are generated, the flowrate will be displayed as zero.</p> <p>The cut-off time has to be entered in seconds - maximum time is 999 seconds (about 15 minutes).</p>



Note !

### 3 - DISPLAY

<b>FUNCTION</b> 31	The large 17mm digits can be set to display total or flowrate. When "total" is selected, both total and flowrate are displayed simultaneously. When "flowrate" is selected, only flowrate will be displayed with it's measuring unit while total will be displayed after pressing SELECT.
<b>LIGHT (BACKLIGHT BRIGHTNESS)</b> 32	The density of the backlight can be set in following range:  0% (OFF) – 20% - 40% - 60% - 80% - 100% (FULL BRIGHTNESS)

### 4 – POWER MANAGEMENT

<b>LCD NEW</b> 41	<p>The calculation of the display-information influences the power consumption significantly. When the application does not require a fast display update, it is <b>strongly advised</b> to select a slow refresh rate. Please understand that NO information will be lost; every pulse will be counted and the output signals will be generated in the normal way. The following can be selected:</p> <p style="text-align: center;">Fast - 1 sec - 3 sec - 15 sec - 30 sec - off.</p> <p><b>Example 3: Battery life-time</b>  <i>battery life-time with a coil pick-up, 1KHz. pulses and FAST update: about 2 years.</i>  <i>battery life-time with a coil pick-up, 1KHz. pulses and 1 sec update: about 5 years.</i></p> <p><b>Note:</b> after a button has been pressed by the operator - the display refresh rate will always switch to FAST for 30 seconds. When "OFF" is selected, the display will be switched off after 30 seconds and will be switched on as soon as a button has been pressed.</p>
<b>BATTERY-MODE</b> 42	<p>The unit has two modes: operational or shelf. After "shelf" has been selected, the unit can be stored for several years; it will not count pulses, the display is switched off but all settings and totals are stored. In this mode, power consumption is extremely low. To wake up the unit again, press the SELECT-key twice.</p>



Note !

### 5 - FLOWMETER

<b>SIGNAL</b> 51	The ERA is able to handle several types of input signal. The type of flowmeter pickup / signal is selected with SETUP 51. Read also par. 4.4.3. Flowmeter input terminal 09-11.			
TYPE OF SIGNAL	EXPLANATION	RESISTANCE	FREQ. / mV	REMARK
NPN	NPN input	100K pull-up	6 kHz.	(open collector)
NPN - LP	NPN input with low pass filter	100K pull-up	2.2 kHz.	(open collector) less sensitive
REED	Reed-switch input	1M pull-up	1.2 kHz.	
REED - LP	Reed-switch input with low pass filter	1M pull-up	120 Hz.	Less sensitive

## 6 - ANALOG OUTPUT

A linear analog (0)4-20mA or 0-10V signal is generated according to the flowrate with a 10 bits resolution. The settings for flowrate (SETUP - 2) influence the analog output directly. The relationship between rate and analog output is set with the following functions:

<b>DISABLE / ENABLE</b> <b>61</b>	The analog output can be disabled. 3.5mA will be generated if a power supply is available but the output is disabled.
<b>MINIMUM FLOWRATE</b> <b>62</b>	Enter here the flowrate at which the output should generate the minimum signal (0/4mA or 0V) - in most applications at flowrate "zero". The number of decimals displayed depend upon SETUP 23. The time and measuring units (L/min for example) are dependant upon SETUP 21 and 22 but are not displayed.
<b>MAXIMUM FLOWRATE</b> <b>63</b>	Enter here the flowrate at which the output should generate the maximum signal (20mA or 10V) - in most applications at maximum flow. The number of decimals displayed depend upon SETUP 23. The time and measuring units (L/min for example) are dependant upon SETUP 21 and 22 but can not be displayed.
<b>CUT-OFF</b> <b>64</b>	To ignore leakage of the flow for example, a low flow cut-off can be set as a percentage of the full range of 16mA, (or 20mA or 10V). When the flow is less than the required rate, the current will be the minimum signal (0/4mA or 10V). <b>Examples:</b>

4mA (SETUP 62)	20mA (SETUP 63)	CUT-OFF (SETUP 64)	REQUIRED RATE	OUTPUT
0 L/min	100 L/min	2%	$(100-0)*2\% = 2.0 \text{ L/min}$	$4+(16*2\%) = 4.32\text{mA}$
20 L/min	800 L/min	3.5%	$(800-20)*3.5\% = 27.3 \text{ L/min}$	$4+(16*3.5\%)=4.56\text{mA}$

<b>TUNE MIN / 4MA</b> <b>65</b>	<p>The initial minimum analog output value is 0/4mA or 0V. However, this value might differ slightly due to external influences such as temperature for example. The 0/4mA value can be tuned precisely with this setting.</p> <ul style="list-style-type: none"> <li>▪ Before tuning the signal, be sure that the analog signal is not being used for any application!</li> </ul> <p>After pressing PROG, the current will be about 4mA (or 0mA / 0V). The current can be increased / decreased with the arrow-keys and is <u>directly active</u>. Press ENTER to store the new value. Remark: the analog output value can be programmed "up-side-down" if desired, so 20mA at minimum flowrate for example!</p>
------------------------------------	---



<b>TUNE MAX / 20MA</b> <b>66</b>	<p>The initial maximum analog output value is 20mA (or 10V). However, this value might differ slightly due to external influences such as temperature for example. The 20mA value can be tuned precisely with this setting.</p> <ul style="list-style-type: none"> <li>▪ Before tuning the signal, be sure that the analog signal is not being used for any application!</li> </ul> <p>After pressing PROG, the current will be about 20mA. The current can be increased / decreased with the arrow-keys and is <u>directly active</u>. Press ENTER to store the new value. Remark: the analog output value can be programmed "up-side-down" if desired, so 4mA at maximum flowrate for example!</p>
-------------------------------------	--



Continued next page >>>



## 6 - ANALOG OUTPUT (CONTINUED)

<b>FILTER 67</b>	This function is used to stabilize the analog output signal. The output value is updated every 0.1 second. With the help of this digital filter a more stable but less precise reading can be obtained. The filter principal is based on three input values: the filter level (01-99), the last analog output value and the last average value. The higher the filter level, the longer the response time on a value change will be. Below, several filter levels with their response times are indicated:			
<b>FILTER VALUE</b>	<b>RESPONSE TIME ON STEP CHANGE OF ANALOG VALUE. TIME IN SECONDS</b>			
	<b>50% INFLUENCE</b>	<b>75% INFLUENCE</b>	<b>90% INFLUENCE</b>	<b>99% INFLUENCE</b>
<b>01</b>	filter disabled	filter disabled	filter disabled	filter disabled
<b>02</b>	0.1 second	0.2 second	0.4 second	0.7 second
<b>03</b>	0.2 second	0.4 second	0.6 second	1.2 seconds
<b>05</b>	0.4 second	0.7 second	1.1 seconds	2.1 seconds
<b>10</b>	0.7 second	1.4 seconds	2.2 seconds	4.4 seconds
<b>20</b>	1.4 seconds	2.8 seconds	4.5 seconds	9.0 seconds
<b>30</b>	2.1 seconds	4 seconds	7 seconds	14 seconds
<b>50</b>	3.5 seconds	7 seconds	11 seconds	23 seconds
<b>75</b>	5.2 seconds	10 seconds	17 seconds	34 seconds
<b>99</b>	6.9 seconds	14 seconds	23 seconds	45 seconds

## 7 - IMPULSE

One transistor or mechanic relay output is available as scaled pulse output according to the accumulated total.

<b>PULSE WIDTH PULSE OUTPUT 71</b>	<p>The pulse width determines the time that the transistor or relay will be switched; in other words the pulse length. The minimum time between the pulses is as long as the selected period time. One period is approx. 7.8 msec. If the value selected is "zero", the pulse output is disabled. The maximum value is 255 periods.</p> <p><b>Note:</b> <i>If the frequency should go out of range - when the flowrate increases for example - an internal buffer will be used to "store the missed pulses": As soon as the flowrate reduces again, the buffer will be "emptied".</i></p> <p><i>It might be that pulses will be missed due to a buffer-overflow, so it is advised to program this setting within it's range.</i></p> <p><i>If a mechanic relay is used for the pulse output, it is recommended to reduce the max. output frequency to 0.5Hz, else the life time will be reduced significantly.</i></p>		
	<b>NUMBER OF PERIODS</b>	<b>PERIOD TIME</b>	<b>MAX. FREQUENCY</b>
	0	disabled	disabled
	1	0,0078 seconds	64 Hz.
	2	0,0156 seconds	32 Hz.
	3	0,0234 seconds	21 Hz.
	64	0,5000 seconds	1 Hz.
	255	1,9922 seconds	0.25 Hz.
<b>DECIMALS 72</b>	This setting determines the decimal position for setting 73.		
	<b>Note:</b> the measuring unit is according to setting 11 (for total)		
<b>AMOUNT 73</b>	According to the measurement unit settings for total, a pulse will be generated every X-quantity. Enter this quantity here while taking the displayed decimal position and measuring unit into account.		



Note !



Note

## 8 - COMMUNICATION (OPTIONAL)

The functions described below deal with hardware that is not part of the standard delivery. Programming of these functions does not have any effect if this hardware has not been installed. Consult Appendix C and the Modbus communication protocol description for a detailed explanation.

<b>SPEED</b> 81	For external control, the following communication speeds can be selected:  1200 - 2400 - 4800 - 9600 baud
<b>BUS ADDRESS</b> 82	For communication purposes, a unique identity can be attributed to every F110-P. This address can vary from 1-255.
<b>MODE</b> 83	The communication protocol is Modbus ASCII or RTU mode. Select OFF, to disable this communication function.

## 9 - OTHERS

<b>TYPE OF MODEL</b> 91	For support and maintenance it is important to have information about the characteristics of the ERA. Your supplier will ask for this information in the case of a serious breakdown or to assess the suitability of your model for upgrade considerations.
<b>VERSION SOFTWARE</b> 92	For support and maintenance it is important to have information about the characteristics of the ERA. Your supplier will ask for this information in the case of a serious breakdown or to assess the suitability of your model for upgrade considerations.
<b>SERIAL NUMBER</b> 93	For support and maintenance it is important to have information about the characteristics of the ERA. Your supplier will ask for this information in the case of a serious breakdown or to assess the suitability of your model for upgrade considerations.
<b>PASSWORD</b> 94	All SETUP-values can be password protected. This protection is disabled with value 0000 (zero). Up to and including 4 digits can be programmed, for example 1234.
<b>TAGNUMBER</b> 95	For identification of the unit and communication purposes, a unique tag number of maximum 7 digits can be entered.

## 4. INSTALLATION

### 4.1. GENERAL DIRECTIONS



Caution !

- Mounting, electrical installation, start-up and maintenance of this instrument may only be carried out by trained personnel authorized by the operator of the facility. Personnel must read and understand this Operating Manual before carrying out its instructions.
- The ERA may only be operated by personnel who are authorized and trained by the operator of the facility. All instructions in this manual are to be observed.
- Ensure that the measuring system is correctly wired up according to the wiring diagrams. Protection against accidental contact is no longer assured when the housing cover is removed or the panel cabinet has been opened (danger from electrical shock). The housing may only be opened by trained personnel.
- Take careful notice of the " Safety rules, instructions and precautionary measures " at the front of this manual.

### 4.2. INSTALLATION / SURROUNDING CONDITIONS

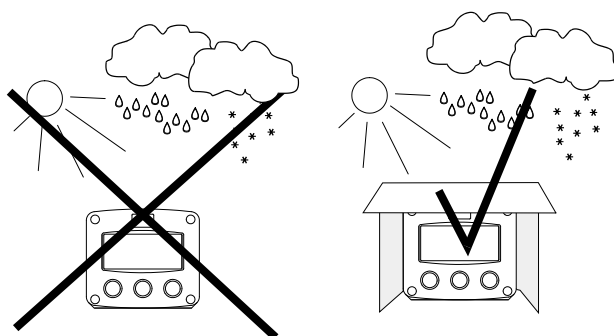

Take the relevant IP classification of the casing into account (see manufactures plate). Even an IP67 (NEMA 4X) casing should NEVER be exposed to strongly varying (weather) conditions.

When panel-mounted, the unit is IP65 (NEMA 4X)!

When used in very cold surroundings or varying climatic conditions, take the necessary precautions against moisture by placing a dry sachet of silica gel, for example, inside the instrument case.

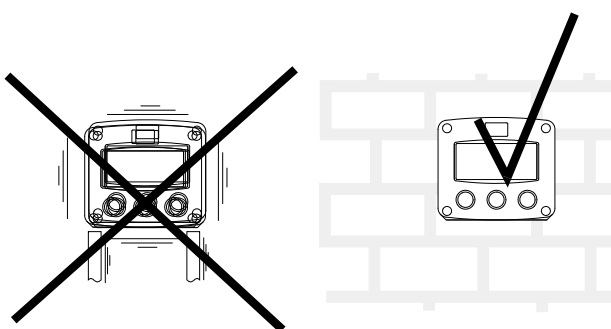

Mount the ERA on a solid structure to avoid vibrations.

### 4.3. DIMENSIONS- ENCLOSURE

#### Aluminum enclosure ERA-RMA

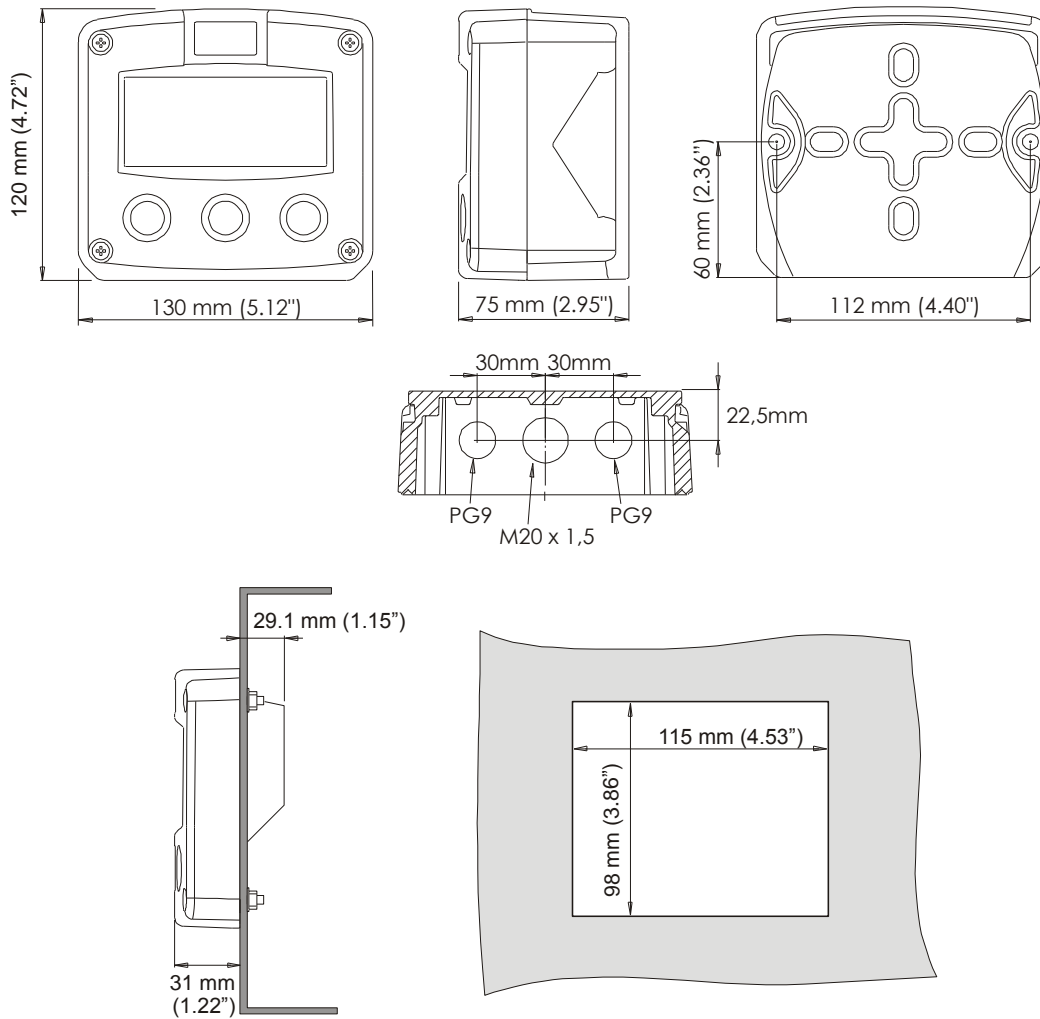

Fig. 5: Dimensions Aluminum enclosure ERA-RMA

**Plastic (GRP) enclosure ERA-RMP:**

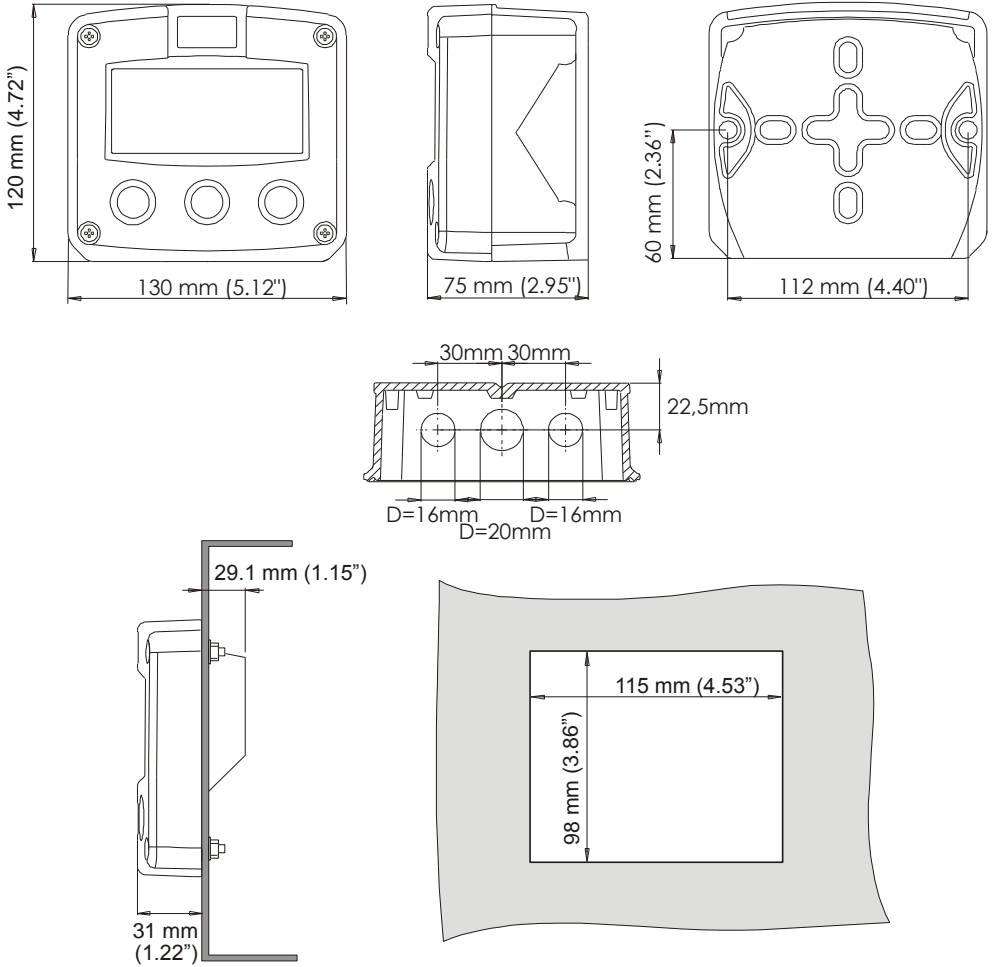

Fig. 6: Dimensions GRP enclosure ERA-RMP.

**Meter Mount enclosure ERA-M:**

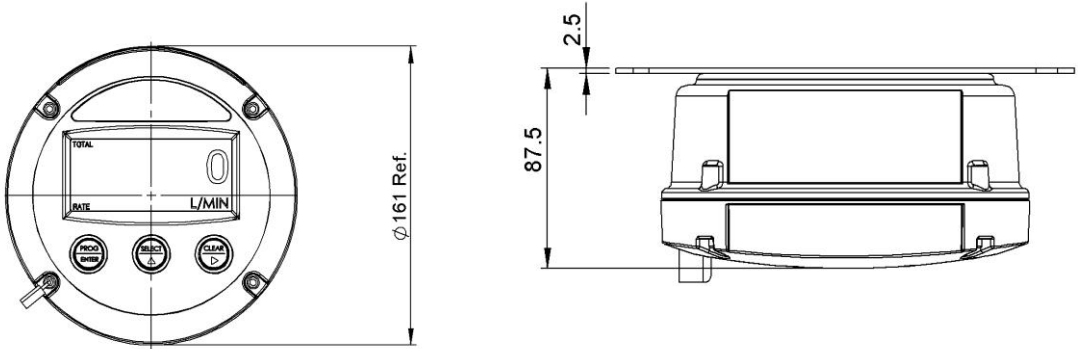

Fig. 7: Dimensions ERA-M series Meter mount enclosure

#### 4.4. INSTALLING THE HARDWARE

##### 4.4.1. INTRODUCTION



- Electro static discharge does inflict irreparable damage to electronics! Before installing or opening the unit, the installer has to discharge himself by touching a well-grounded object.
- This unit must be installed in accordance with the EMC guidelines (Electro Magnetic Compatibility).



##### **Aluminum enclosures**

- When installed in an aluminum enclosure and a potentially explosive atmosphere requiring apparatus of equipment protection level Ga and Da, the unit must be installed such that, even in the event of rare incidents, an ignition source due to impact or friction sparks between the enclosure and iron/steel is excluded.
- Do ground the aluminum enclosure properly as indicated.

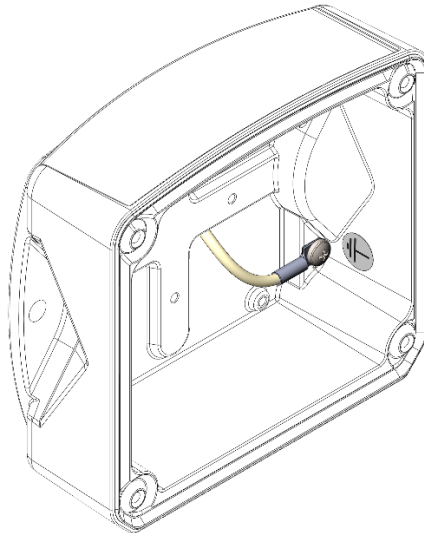

*Fig. 8: Grounding aluminum enclosure*

##### **FOR INSTALLATION, PAY EMPHATIC ATTENTION TO:**

- Separate cable glands with effective IP67 (NEMA4X) seals for all wires.
- Unused cable entries: ensure that you fit IP67 (NEMA4X) plugs to maintain rating.
- A reliable ground connection for both the sensor, and if applicable, for the metal casing.
- An effective screened cable for the input signal, and grounding of its screen to terminal 9 (GND) or at the sensor itself, whichever is appropriate to the application.

#### 4.4.2. VOLTAGE SELECTION SENSOR SUPPLY

##### Type PB / PX (AP) - battery powered and output loop-powered applications:

Terminal 11 provides a limited supply voltage of 3.2 V DC (coil signals 1.2V) for the signal output of the flowmeter.



Note !

**Note:** This voltage MAY NOT be used to power the flowmeters electronics, converters etc, as it will not provide adequate sustained power ! All energy used by the flowmeters pick-up will directly influence the battery life-time. It is strongly advised to use a "zero power" pickup such as a coil or reed-switch when operating without external power. It is possible to use some low power NPN or PNP output signals, but the battery life time will be significantly reduced (consult your distributor).

##### Type PD: Sensor supply: 1.2 / 3.2V / 8.2V / 12V or 24 V DC:

With this option, a real power supply for the sensor is available. The flowmeter can be powered with 8.2 / 12 or 24 V DC. Total power consumption PD: max. 50mA@24V.

The voltage is selected with the three switches inside the enclosure.



- **Warning:** be sure that all the leads to the terminals are disconnected from the unit when the internal plastic protection cover has been removed !

First, remove the terminal strip(s) after which the internal plastic cover can be removed. The switches are located in the top left corner (type PD) as indicated:

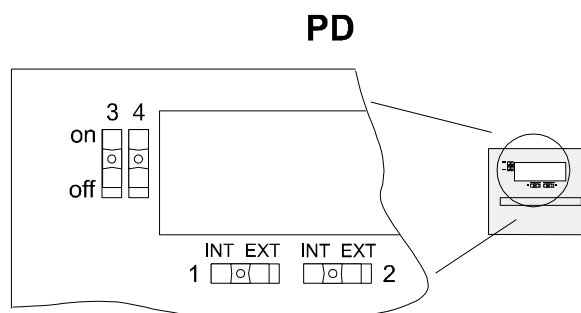

Fig. 9: Switch setting sensor supply voltage.

##### Switch positions

SENSOR A	
SWITCH 1	VOLTAGE
internal	3.2 V DC
external	switch 3+4

SENSOR B	
SWITCH 2	VOLTAGE

VOLTAGE SELECTION		
SWITCH 3	SWITCH 4	VOLTAGE
on	on	8.2 V DC
on	off	12 V DC
off	off	23 V DC

**Function switch 1:** voltage selection sensor A - terminal 11.

**Function switch 2:** not available for this model.

**Function switch 3+4:** the combination of these switches determine the voltage as indicated. Do move switch 1 and / or switch 2 to the OFF position to enable the selected voltage with switch 3+4.

### 4.4.3. TERMINAL CONNECTORS

The following terminal connectors are available:

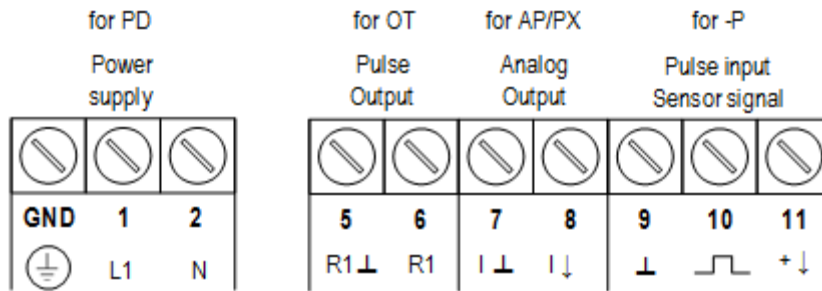

Fig. 10: Overview of terminal connectors standard configuration ERA and options.

#### REMARKS: TERMINAL CONNECTORS:

**Terminal GND- 01- 02: Power Supply - only available with type PD:**

TYPE	SENSOR SUPPLY	Terminal			backlight
		GND	01	02	
<b>PD</b> 8-30V DC	8,2 / 12 / 24V max. 50mA	DC -	DC +	-	

=option



**Note: for power supply type PX: please read Terminal 07-08 !**

#### Terminal 05-06; scaled pulse output R1:

Setup 7 (par. 3.4.4.) determines the pulse output function. The maximum pulse frequency of this output is 60Hz. If a relay output option has been supplied, be sure that the output frequency does not exceed 5Hz or else the life-time of the relay will be reduced significantly.

#### Type OT:

A passive transistor output is available with this option. Max. driving capacity 300mA@50V DC.

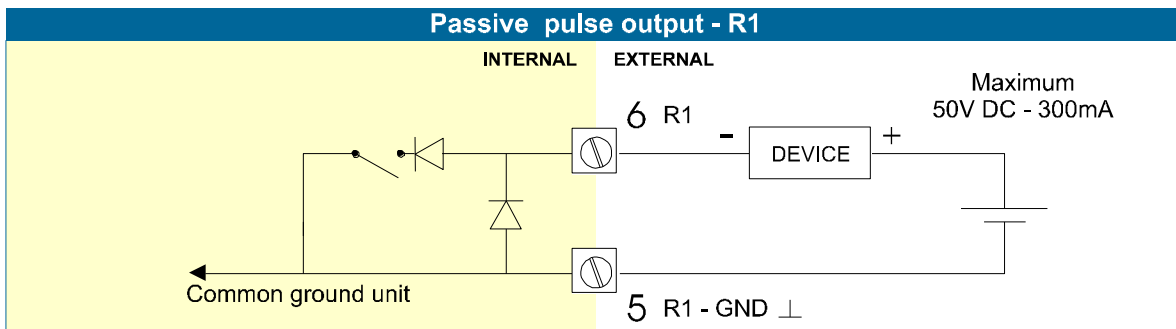



**Terminal 07-08; basic POWER SUPPLY - type PX - output loop powered:**

Connect an external power supply of 8-30VDC to these terminals or a 4-20mA loop.

Do connect the "-" to terminal 7 and the "+" to terminal 8. When power is applied to these terminals, the (optional) internal battery will be disabled / enabled automatically to extend the battery life time.



Caution !

Only valid for standard passive output type AP!

**Terminal 07-08 analog output (SETUP 7) :**

An analog output signal proportional to the flowrate is available as standard.

**Type AP:**

A passive 4-20mA signal proportional to the flowrate is available with this option. When a power supply is connected but the output is disabled, a 3.5mA signal will be generated.

Max. driving capacity 1000 Ohm. This output does loop power the unit as well (type PX).

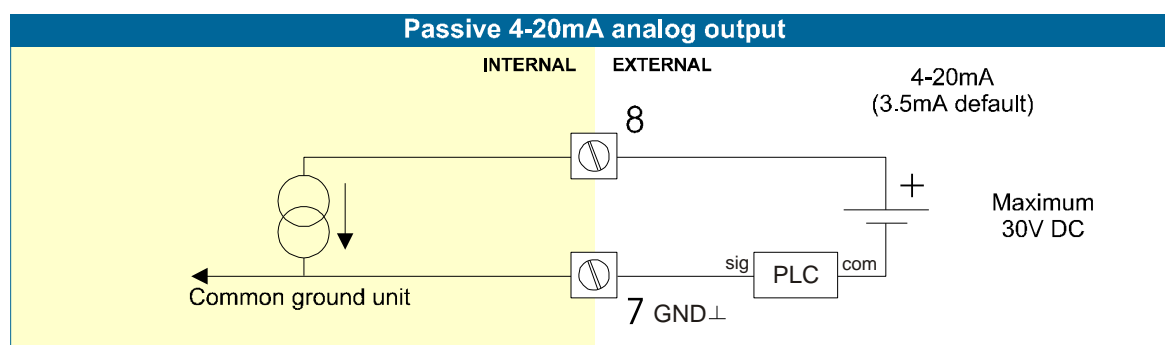
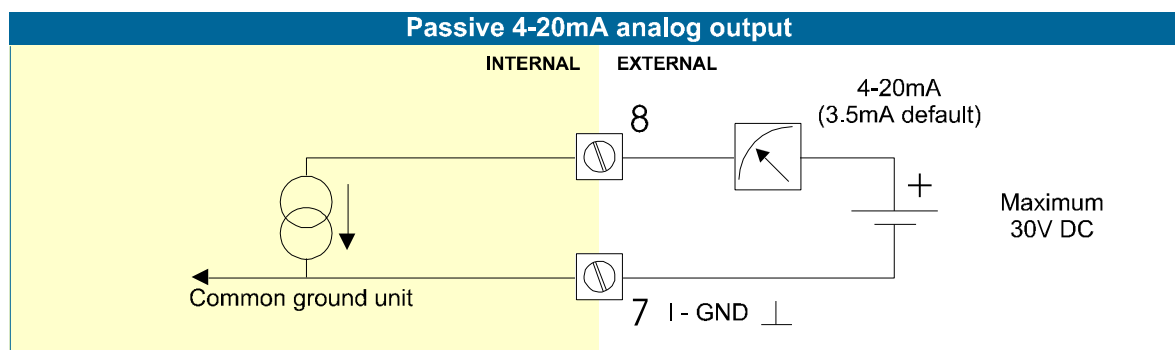
**Terminal 09-11; Flowmeter input :**

Two basic types of digital flowmeter signals can be connected to the unit: Reed or NPN. The screen of the signal wire must be connected to the common ground terminal 09 (unless earthed at the sensor itself).

The maximum input frequency is approximately 10 kHz (depending on the type of signal). The input signal type has to be selected with the correct SETUP-function (read par. 3.2.3.)

**Pulse-signal NPN / NPN-LP:**

The ERA is suitable for use with flowmeters which have a NPN output signal. For reliable pulse detection, the pulse amplitude has to go below 1.2V. Signal setting NPN-LP employs a low-pass signal noise filter, which limits the maximum input frequency - read par. 3.2.3.

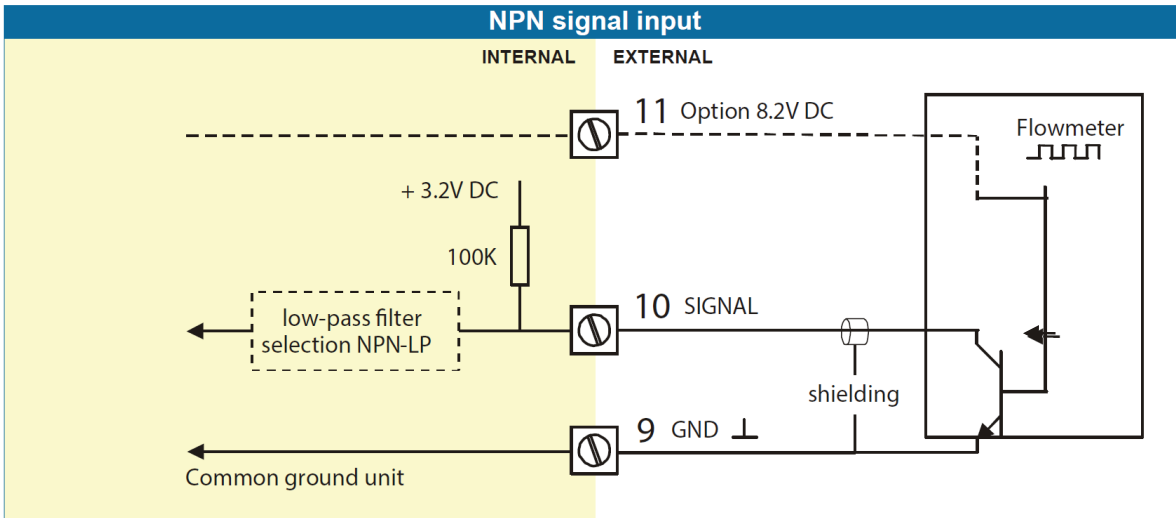

**Reed-switch:**

The ERA is suitable for use with flowmeters which have a reed-switch. To avoid pulse bounce from the reed-switch, it is advised to select REED LP - low-pass filter (read par. 3.2.3.)

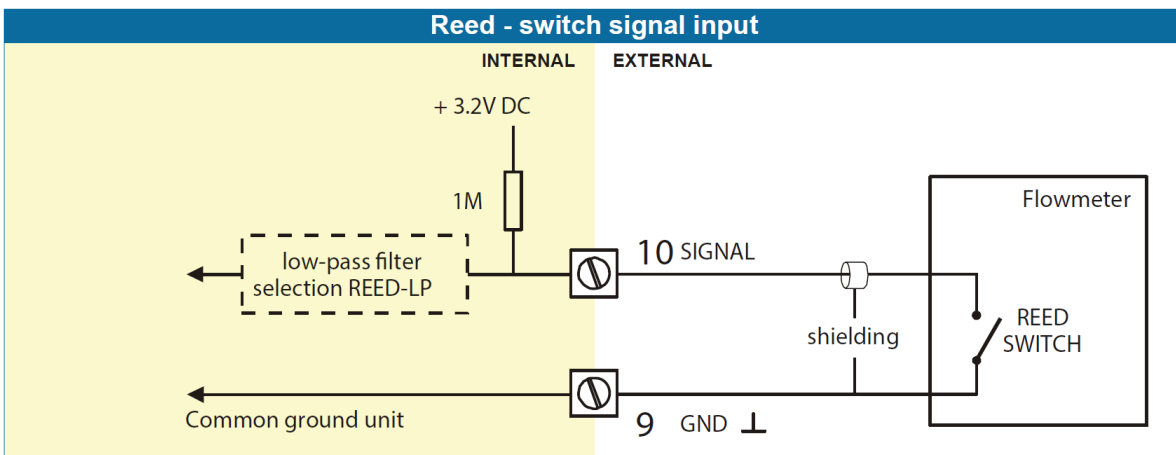

## 5. MAINTENANCE

### 5.1. GENERAL DIRECTIONS



Caution !

- Mounting, electrical installation, start-up and maintenance of the instrument may only be carried out by trained personnel authorized by the operator of the facility. Personnel must read and understand this Operating Manual before carrying out its instructions.
- The ERA may only be operated by personnel who are authorized and trained by the operator of the facility. All instructions in this manual are to be observed.
- Ensure that the measuring system is correctly wired up according to the wiring diagrams. Protection against accidental contact is no longer assured when the housing cover is removed or the panel cabinet has been opened (danger from electrical shock). The housing may only be opened by trained personnel.
- Take careful notice of the " Safety rules, instructions and precautionary measures " in the front of this manual.

The ERA does not require special maintenance unless it is used in low-temperature applications or surroundings with high humidity (above 90% annual mean). It is the users responsibility to take all precautions to dehumidify the internal atmosphere of the ERA in such a way that no condensation will occur, for example by placing dry silica-gel sachet in the casing just before closing it. Furthermore, it is required to replace or dry the silica gel periodically as advised by the silica gel supplier.

#### **Battery life-time:**

It is influenced by several issues:

- Type of sensor:
- Input frequency: the higher the frequency, the shorter the battery life-time.
- Flowrate calculation: the lower number of pulses (SETUP 26) the shorter the battery life-time.
- Analog output signal; be sure that an external power supply is connected or that the function is disabled if not in use; or else it will have a influence on the battery life-time (SETUP 61).
- Display update: fast display update uses significantly more power; SETUP 41.
- Pulse output and communications .
- Low temperatures; the available power will be less due to battery chemistry.



Note !

**Note:** *It is strongly advised to disable unused functions.*

#### **Check periodically:**

- The condition of the casing, cable glands and front panel.
- The input/output wiring for reliability and aging symptoms.
- The process accuracy. As a result of wear and tear, re-calibration of the flowmeter might be necessary. Do not forget to re-enter any subsequent K-factor alterations.
- The indication for low-battery.
- Clean the casing with soapy-water. Do not use any aggressive solvents as these might damage the coating.

### 6.2. REPAIR

This product cannot be repaired by the user and must be replaced with an equivalent certified product. Repairs should only be carried out by the manufacturer or his authorized agent.

## APPENDIX A: TECHNICAL SPECIFICATION

<b>GENERAL</b>	
<b>Display</b>	
Type	High intensity reflective numeric and alphanumeric LCD, UV-resistant.
Digits	Seven 17mm (0.67") and eleven 8mm (0.31"). Various symbols and measuring units.
Refresh rate	User definable: 8 times/sec - 30 secs.
Type ZB	Transflective LCD with green LED backlight. Good readings in full sunlight and darkness. Note: only available for safe area applications. Power requirements: 12-24V DC + 10% or type PD, PF, PM. Power consumption max. 1 Watt.
<b>Enclosures</b>	
General	Die-cast aluminum or GRP (Glassfibre Reinforced Polyamide) enclosure with Polycarbonate window, silicone and EPDM gaskets. UV stabilized and flame retardant material.
Control Keys	Three industrial micro-switch keys. UV-resistant silicone keypad.
Painting	Aluminum enclosure only: UV-resistant 2-component industrial painting.
Panel-mount enclosures	Dimensions: 130 x 120 x 60mm (5.10" x 4.72" x 2.38") – LxHxD.
Classification	IP65 / NEMA 4X
Panel cut-out	115 x 98mm (4.53" x 3.86") LxH.
Type ERA-RMP	GRP panel-mount enclosure
Type ERA-RMA	Aluminum panel-mount enclosure
Field/wall-mount enclosures	Dimensions: 130 x 120 x 75mm (5.10" x 4.72" x 2.95") – LxHxD.
Classification	IP67 / NEMA4X
Aluminum enclosures	
Type ERA-RMA	Drilling: 2x PG9 – 1x M20.
GRP enclosures	
Type ERA-RMP	Drilling: 2x 16mm (0.63") – 1x 20mm (0.78").
Round meter-mount enclosures	Dimensions: $\varnothing$ 161 x 87.5mm (5.10" x 2.38") – $\varnothing$ xD.
Classification	IP67 / NEMA 4X
Type ERA-M	Aluminum meter-mount enclosure
<b>Operating temperature</b>	
Operational	-40°C to +80°C (-40°F to +176°F)
Intrinsically Safe	-40°C to +70°C (-40°F to +158°F)
<b>Power supply</b>	
Type PB	Lithium battery - life-time depends upon settings - up to 5 years.
Type PD	8-24V AC / DC $\pm$ 10%. Power consumption max. 10 Watt. Intrinsically safe: 16-30V DC; power consumption max. 0.75 Watt.
Type PX	Output loop powered: 8-30V DC. Power consumption max. 0.5 Watt.
<b>Sensor excitation</b>	
Type PB / PX	3.2V DC for pulse signals and 1.2V DC for coil pick-up. Note: This is not a real sensor supply. Only suitable for pulse sensors with a very low power consumption like coils (sine wave) and reed-switches.
Type PD	1.2 / 3.2 / 8.2 / 12 and 24V DC - max. 50mA@24V DC
<b>Terminal connections</b>	
Type:	Removable plug-in terminal strip. Wire max. 1.5mm <sup>2</sup> and 2.5mm <sup>2</sup> (Type PM / PF)
<b>Data protection</b>	
Type	EEPROM backup of all setting. Backup of running totals every minute. Data retention at least 10 years.
Password	Configuration settings can be password protected.

Directives and standards	
EMC	EN 61326-1; FCC 47 CFR part 15
LVD	EN/IEC 61010-1
RoHS	EN 50581
IP & NEMA	EN 60529; NEMA 250

## INPUTS

Flowmeter	
Type P	NPN, Reed-switch.
Frequency	Minimum 0 Hz - maximum 7 kHz for total and flowrate. Maximum frequency depends on signal type and internal low-pass filter. E.g. Reed switch with low-pass filter: max. frequency 120 Hz.
K-Factor	0.000010 - 9,999,999 with variable decimal position.
Low-pass filter	Available for all pulse signals.

## OUTPUTS

Analog output	
Function	transmitting flowrate.
Accuracy	10 bit. Error < 0.05% - update 10 times a second. Software function to calibrate the 4.00mA and 20.00mA levels precisely within set-up.
Load	max. 1 kOhm
Type AP	Passive 4-20mA output - output loop powered (type PX).

Switch output(s)	
Function	One pulse output - transmitting accumulated total.
Pulse output	Max. frequency 60Hz. Pulse length user definable between 7,8msec up to 2 seconds.
Type OT	Passive transistor output - not isolated. Load max. 50V DC - 300mA.

## OPERATIONAL

Operator functions	
Displayed functions	<ul style="list-style-type: none"> <li>total and/or flowrate.</li> <li>total and accumulated total.</li> </ul> total can be reset to zero by pressing the CLEAR-key twice.

Total	
Digits	7 digits.
Units	L, m3, GAL, USGAL, KG, lb, bbl, no unit.
Decimals	0 - 1 - 2 or 3.
<b>Note</b>	total can be reset to zero.

Accumulated total	
Digits	11 digits.
Units / decimals	according to selection for total.

Flowrate	
Digits	7 digits.
Units	mL, L, m3, Gallons, KG, Ton, lb, bl, cf, RND, ft3, scf, Nm3, NI, igal - no units.
Decimals	0 - 1 - 2 or 3.
Time units	/sec - /min - /hr - /day.

## APPENDIX B: PROBLEM SOLVING

In this appendix, several problems are included that can occur when the ERA is going to be installed or while it is in operation.

### Flowmeter does not generate pulses:

Check:

- Signal selection SETUP - 41,
- Pulse amplitude (par. 4.4.3.),
- Flowmeter, wiring and connection of terminal connectors (par. 4.4.3.),
- Power supply of flowmeter (par. 4.4.2.).

### Flowmeter generates "too many pulses":

Check:

- Settings for total and Flowrate: SETUP 11-14 and 21-27,
- Type of signal selected with actual signal generated - SETUP - 41,
- Sensitivity of coil input - SETUP - 41 and par. 4.4.3.
- Proper grounding of the ERA - par. 4.4.1.
- Use screened wire for flowmeter signals and connect screen to terminal 9. (unless connected at sensor)

### Analog output does not function properly:

Check:

- SETUP 51 - is the function enabled?
- SETUP 52 / 53: are the flow-levels programmed correctly?
- connection of the external power-supply according to the specification.

### Pulse output does not function:

Check:

- SETUP 63 - pulse per "x" quantity; is the value programmed reasonable and will the maximum output be under 20Hz?
- SETUP 61 - impulse width; is the external device able to recognize the selected pulse width and frequency?

### Flowrate displays "0 / zero" while there is flow (total is counting):

Check:

- SETUP 22 / 25: are the K-factor and time unit correct?
- SETUP 26 / 27: The unit has to count the number of pulses according to SETUP 26 within the time according to SETUP 27. Make sure that 27 is set to 10.0 seconds for example : the result is that the unit has at least 10 seconds time to measure the number of pulses according to SETUP 26.

### The password is unknown:

If the password is not 1234, there is only one possibility left: call your supplier.

### ALARM

When the alarm flag starts to blink an internal alarm condition has occurred. Press the "select button" several times to display the 5-digit error code. The codes are:

- 0001: irrecoverable display-data error: data on the display might be corrupted.
- 0002: irrecoverable data-storage error: the programming cycle might have gone wrong: check programmed values.
- 0003: error 1 and error 2 occurred simultaneously

If the alarm occurs more often or stays active for a longer time, please contact your supplier.

## INDEX OF THIS MANUAL

accumulated Total .....	8	time unit .....	14
actual settings .....	32	Flowrate.....	8
alarm.....	8	Installation .....	19
analog		IP classification.....	19
cut-off value .....	16	keys .....	7
disable/enable.....	16	low-battery.....	8
filter .....	17	main-function.....	10
flowrate max.....	16	maintenance.....	27
flowrate min.....	16	model.....	18
<i>output loop powered.</i> .....	25	Operator level.....	8
tune / calibrate .....	16	password .....	18, 30
Analog output .....	25	power supply .....	24, 25
backlight		Problem solving.....	30
density.....	15	pulse output	
battery life time .....	27	pulse length / period time.....	17
Clear Total.....	8	pulse per quantity .....	17
Communication		Pulse output .....	24
address .....	18	Pulse-signal NPN .....	26
baudrate.....	18	Reed-switch:.....	26
mode .....	18	serial number.....	18
Configuration .....	9	SETUP-level.....	9
dimensions .....	20	shelf mode.....	15
display		subfunction .....	10
function .....	15	tagnumber .....	18
display update .....	15	Technical specification .....	28
flowmeter		terminal connectors .....	24
signal.....	15	total	
flowmeter input .....	25	decimals.....	13
flowrate		decimals k-factor.....	13
calculation .....	14	k-factor .....	13
cut-off time .....	14	measuring unit .....	13
decimals.....	14	Total.....	8
decimals k-factor.....	14	version software .....	18
k-factor .....	14	Voltage selection sensor .....	23
measuring unit .....	14		

## LIST OF FIGURES IN THIS MANUAL

Fig. 1: Typical application for the ERA .....	5
Fig. 2: Control Panel.....	7
Fig. 3: Example of display information during process. ....	8
Fig. 4: Example of low-battery alarm.....	8
Fig. 5: Dimensions Aluminum enclosure ERA-RMA .....	20
Fig. 6: Dimensions GRP enclosure ERA-RMP. ....	21
Fig. 7: Dimensions ERA-M series Meter mount enclosure .....	21
Fig. 8: Grounding aluminum enclosure .....	22
Fig. 9: Switch setting sensor supply voltage. ....	23
Fig. 10: Overview of terminal connectors standard configuration ERA and options.....	24

## LIST OF CONFIGURATION SETTINGS

SETTING	DEFAULT	DATE :	DATE :
<b>1 - TOTAL</b>	Enter your settings here		
11 unit	L		
12 decimals	0000000		
13 K-factor	0000001		
14 decimals K-factor	0		
<b>2 - FLOWRATE</b>			
21 unit	L		
22 time unit	/min		
23 decimals	0000000		
24 K-factor	0000001		
25 decimals K-factor	0		
26 calculation / pulses	10		
27 cut-off time	30.0 sec.		
<b>3 - DISPLAY</b>			
31 function	total		
32 light	100%		
<b>4 - POWER MANAGEMENT</b>			
41 LCD new	1 sec.		
42 Batt mode	operate		
<b>5 - FLOWMETER</b>			
51 signal	reed_lp		
<b>6- ANALOG OUTPUT</b>			
61 output	disable		
62 min. flowrate 4-mA	0000000		
63 max. flowrate 20mA	99999		
64 cut off percentage	0.0%		
65 tune min - 4mA	160		
66 tune max - 20mA	6656		
67 filter	0		
<b>7 IMPULSE</b>			
71 pulse width	0.000		
72 decimals	0		
73 amount	0001000		
<b>8 - COMMUNICATION</b>			
81 speed	9600		
82 address	1		
83 mode	BUS-RTU		
<b>9 - OTHERS</b>			
91 model	G_110-P		
92 software version	03.03.xx		
93 serial number	xxxxxxx		
94 password	0000		
95 tagnumber	0000000		