

PACSystems™ RSTi-EP

MODBUS® NETWORK ADAPTER MODULE (EPXMBE001)

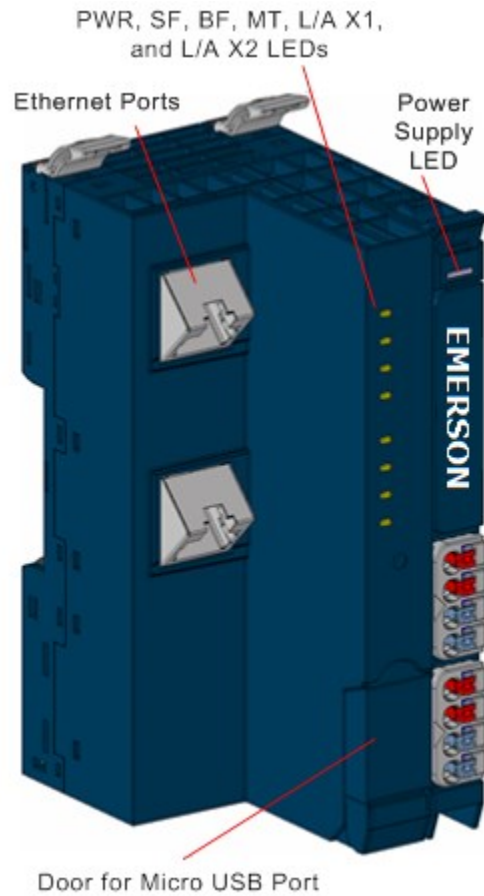

Warning Notes as Used in this Publication



Warning

Warning notices are used in this publication to emphasize that hazardous voltages, currents, temperatures, or other conditions that could cause personal injury exist in this equipment or may be associated with its use.

In situations where inattention could cause either personal injury or damage to equipment, a Warning notice is used.

Notes: *Notes merely call attention to information that is especially significant to understanding and operating the equipment.*

These instructions do not purport to cover all details or variations in equipment, nor to provide for every possible contingency to be met during installation, operation, and maintenance. The information is supplied for informational purposes only, and Emerson makes no warranty as to the accuracy of the information included herein. Changes, modifications, and/or improvements to equipment and specifications are made periodically and these changes may or may not be reflected herein. It is understood that Emerson may make changes, modifications, or improvements to the equipment referenced herein or to the document itself at any time. This document is intended for trained personnel familiar with the Emerson products referenced herein.

Emerson may have patents or pending patent applications covering subject matter in this document. The furnishing of this document does not provide any license whatsoever to any of these patents.

Emerson provides this document and the information included therein as-is and without warranty of any kind, expressed or implied, including but not limited to any implied statutory warranty of merchantability or fitness for particular purpose.

Product Description

The EPXMBE001 network adapter is a Modbus TCP participant developed according to IEC 61158. The network adapter is the head module for the RSTi-EP communication bus, to which up to 64 active RSTi-EP modules can be connected. The Modbus TCP network adapter has two Ethernet ports and an integrated switch.

The network adapter can be accessed with a system-independent web server application via the USB service interface or the Ethernet. Thus, all information, such as diagnostics, status values and parameters, can be read and all connected modules can be simulated or forced.

The station's main power supply is integrated in the network adapter. Power is supplied via two 4-pole connectors, separated into the input and output current paths.

Caution, the RSTi-EP station is usually installed on a horizontally positioned DIN rail. Installation on vertically positioned DIN rails is also possible. However, the heat dissipation is reduced such that the derating values change (refer to the section, Thermal Derating).

Modules should to be allowed to de-energize for a minimum 10 seconds after power down, prior to starting any maintenance activity. The network adapter cannot be hot-swapped.

Refer to the RSTi-EP Slice I/O User Manual (GFK-2958) for additional information.

Refer to the RSTi-EP Power Supply Reference Guide, a software utility available on PAC Machine Edition V9.00, for detailed power-feed requirements.

Module Features

- Supports up to 64 active RSTi-EP modules
- Spring-style technology for ease of wiring
- DIN rail mounted
- Double-click installation for positive indication of correct installation
- Built-in Web Server for diagnostic information and firmware update through Ethernet and micro USB port
- Option of fixed or DHCP IP address configuration
- Support for daisy-chain/line, star topologies

Ordering Information

Module	Description
EPXMBE001	RSTi-EP Slice I/O Modbus TCP Network Adapter

Specifications

Specification	EPXMBE001	
System data		
Connection	2 x RJ-45	
Fieldbus protocol	Modbus TCP	
Process image	Input data width	max. 8 kBytes
	Parameter data	max. 1024 kBytes
	Diagnostic data	max. 1024 kBytes
Number of modules	max. 64 active	
Configuration interface	Micro USB 2.0	
Transfer rate	Fieldbus	10 Mbps/100 Mbps
	RTSi-EP system bus	Max. 48 Mbps
Supply		
Supply voltage for system and inputs	20.4V – 28.8V	
Supply voltage for outputs	20.4V – 28.8V	
Max. feed-in current for input modules	10 A	
Max. feed-in current for output modules	10 A	
Current consumption from system current path I _{sys}	112 mA	
Connection data		
Type of connection	Spring style	
Conductor cross-section	Single-wired, fine-wired	0.14 – 1.5 mm ² (AWG 26 – 16)
General data		
Operating temperature	-20°C to +60°C (-4 °F to +140 °F)	
Storage temperature	-40°C to +85°C (-40 °F to +185 °F)	
Air humidity (operation/transport)	5% to 95%, noncondensing as per IEC 61131-2	
Width	52 mm (2.05 in)	
Depth	76 mm (2.99 in)	
Height	120 mm (4.72 in)	
Weight	223 g (7.87 oz)	

LED's

LED Status Indicators

LED	Indication	LED State/Description
PWR	Power LED	Green: Supply voltage connected
SF	System Fault	Red: Configuration error, or error in the network adapter, or error in a module, or there is a new diagnostic report Red flashing: Station in Force mode
BF	Bus fault	Red: No connection to the fieldbus Red flashing: Configuration error, no connection to the control unit, or error in the parameter set
MT	Maintenance Required	Yellow: Error on the system bus or fieldbus
L/A X1	Connection/Active	Green / Yellow[†]: Connection established between port 1 of the network adapter and another field device Green flashing / Yellow flashing[†]: Data being exchanged on port 1

LED	Indication	LED State/Description
L/A X2	Connection/Active	Green: Connection established between port 2 of the network adapter and another field device Green flashing: Data being exchanged on port 2
†Green: Transfer rate 100 MBit/s Yellow: Transfer rate 10 MBit/s		

LED Indicators

LED	EPXMBE001
Power Supply	Green: Supply voltage > 18 V DC Red: At least one current path < 18 V
3.1	Green: Input current path supply voltage > 18 V DC
3.2	Red: Input current path supply voltage < 18 V DC
3.3	
3.4	Red: Internal fuse defective
4.1	Green: Output current path supply voltage > 18 V DC
4.2	Red: Output current path supply voltage < 18 V DC
4.3	
4.4	Red: Internal fuse defective

Field Wiring

The connection frame has one connector, and two 24 V DC wires can be connected to each connector, along with two ground connections. Those four connectors are used as shown in the following figure. The Spring style technology allows either finely stranded or solid wire with crimped wire-end ferrules or ultrasonically welded wires, each with a maximum cross-section of 1.5 mm² (16 guage), to be inserted easily through the opening in the clamping terminal without having to use tools. To insert fine stranded wires without wire-end ferrules, the pusher must be pressed in with a screwdriver and released to latch the wire.

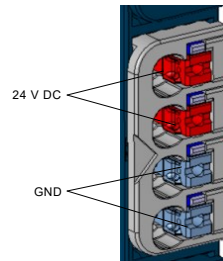

Connector Block

Connector Specifications:

- Conductor cross-section 0.14 to 1.5 mm² (26 – 16 guage)
- Maximum ampacity: 10 A
- 4-pole

The modules do not have a fused sensor/activator power supply. All cables to the connected sensors/actuators must be fused corresponding to their conductor cross-sections (as per Standard DIN EN 60204-1, section 12).

Refer to the *RSTi-EP Slice I/O User Manual* (GFK-2958) for additional information.

For technical assistance, go to <https://www.emerson.com/Industrial-Automation-Controls/support>

Connection Diagrams

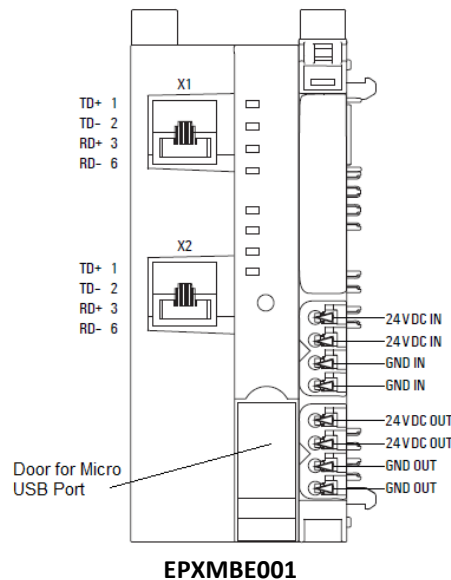

Connection Block Diagrams

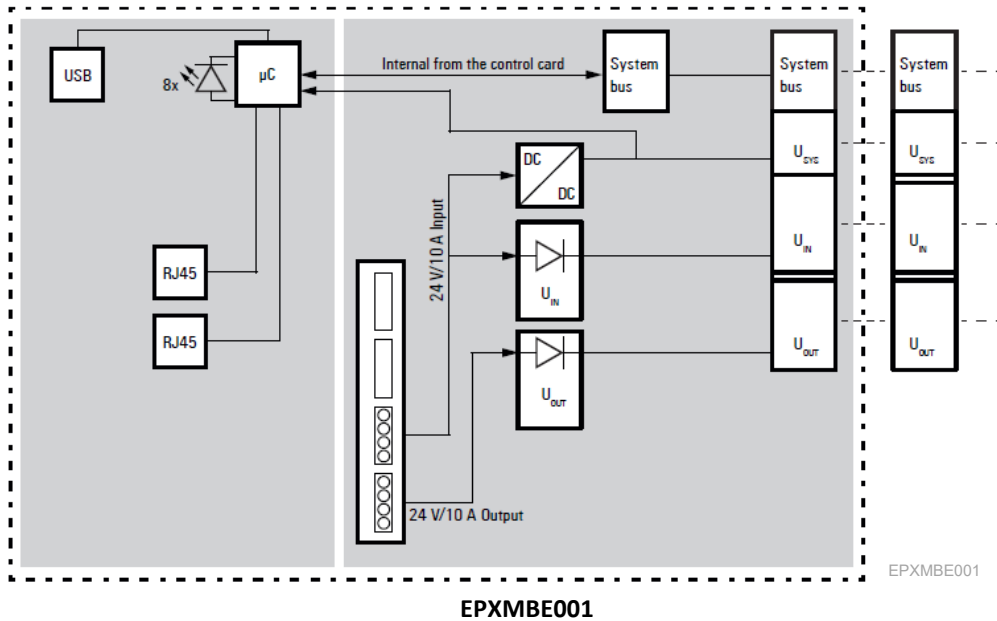

Installation in Hazardous Areas

⚠ WARNING

- EQUIPMENT LABELED WITH REFERENCE TO CLASS I, GROUPS A, B, C & D, DIV. 2 HAZARDOUS AREAS IS SUITABLE FOR USE IN CLASS I, DIVISION 2, GROUPS A, B, C, D OR NON-HAZARDOUS AREAS ONLY
- EXPLOSION HAZARD - SUBSTITUTION OF COMPONENTS MAY IMPAIR SUITABILITY FOR CLASS I, DIVISION 2;
- EXPLOSION HAZARD - WHEN IN HAZARDOUS AREAS, TURN OFF POWER BEFORE REPLACING OR WIRING MODULES; AND
- EXPLOSION HAZARD - DO NOT CONNECT OR DISCONNECT EQUIPMENT UNLESS POWER HAS BEEN SWITCHED OFF OR THE AREA IS KNOWN TO BE NONHAZARDOUS.

ATEX Marking

Ⓔ II 3 G Ex nA IIC T4 Gc

Ta: -20°C to +60°C (-4° F to +140 °F)

Thermal Derating

The power supply is restricted according to the temperature. The following values apply for the horizontal and vertical positioning of the RSTi-EP station:

Temperature-dependent Values for the Power Supply

Power Supply	Horizontal	Vertical
Network adapter power supply	60°C (140 °F) : 2 x 8 A	55°C (131 °F) : 2 x 6 A
	55°C (131 °F) : 2 x 10 A	50°C (122 °F) : 2 x 8 A
Power-feed module power supply	60°C (140 °F) : 1 x 10 A	55°C (131 °F) : 1 x 8 A

Refer to the RSTi-EP Slice I/O Module User Manual (GFK-2958) for additional information.

Supported Modules and Power Supplies

The following modules can be used with this release of the RSTi-EP Profibus Network Adaptor :

Catalog Number	Module Description
Digital Input Modules	
EP-1214	Digital Input, 4 Points, Positive Logic 24VDC, 2,3, or 4 Wire
EP-1218	Digital Input, 8 Points, Positive Logic, 24VDC 2 Wire
EP-1318	Digital Input, 8 Points, Positive Logic, 24VDC 3 Wire
EP-125F	Digital Input, 16 Points, Positive Logic, 24VDC, 1 Wire
EP-153F	Digital Input, 16 Points, Negative Logic, 24VDC, 1 Wire
EP-12F4	Digital Input, 4 Points, Positive Logic 24VDC, 2,3, or 4 Wire, Time stamp
EP-1804	Digital Input, 4 Points 110/230 VAC (65 – 277 VAC), 2 Wire, Isolated
Digital Output Modules	
EP-2214	Digital Output, 4 Points, Positive Logic 24VDC, 0.5A, 2,3, or 4 Wire
EP-2614	Digital Output, 4 Points, Positive Logic 24VDC, 2.0A, 2,3, or 4 Wire
EP-2634	Digital Output, 4 Points, Positive/Negative Logic 24VDC, 2.0A, 2,3, or 4 Wire
EP-2218	Digital Output, 8 Points, Positive Logic, 24VDC, 0.5A, 2 Wire
EP-225F	Digital Output, 16 Points, Positive Logic, 24VDC, 0.5A, 1 Wire
EP-291F	Digital Output, 16 Points, Negative Logic, 24VDC, 0.5A, 1 Wire
Digital Relay Output Modules	
EP-2714	Digital Relay Output, 4 Points, Positive Logic, 24 - 220 VDC/VAC, 6A, 2 Wire
EP-2814	Solid-state Relay Output Module
Analog Input Modules	
EP-3164	Analog Input, 4 Channels Voltage/Current 16 Bits 2, 3, or 4 Wire
EP-3264	Analog Input, 4 Channels Voltage/Current 16 Bits with Diagnostics 2, 3, or 4 Wire
EP-3124	Analog Input, 4 Channels Voltage/Current 12 Bits 2, 3, or 4 Wire
EP-3368	Analog Input, 8 Channels Current 16 Bits 2, 3, or 4 Wire
EP-3468	Analog Input, 8 Channels Current 16 Bits 2, 3, or 4 Wire, Channel Diagnostic
EP-3664	Analog Input, 4 Channels Voltage/Current 16 Bits with Diagnostics 2, 3, or 4 Wire, Differential Input
EP-3704	Analog Input, 4 Channels RTD 16 Bits with Diagnostics 2, 3, or 4 Wire
EP-3804	Analog Input, 4 Channels TC 16 Bits with Diagnostics 2, 3, or 4 Wire
EP-1813	Power Measurement Module, 8 Channels
Analog Output Modules	
EP-4164	Analog Output, 4 Channels Voltage/Current 16 Bits 2, 3, or 4 Wire
EP-4264	Analog Output, 4 Channels Voltage/Current 16 Bits with Diagnostics 2, 3, or 4 Wire
Speciality Modules	
EP-5111	1 Channel High Speed Counter, AB 100 kHz 1 DO 24VDC, 0.5A
EP-5112	2 Channel High Speed Counter, AB 100 kHz
EP-5212	2 Channel Frequency Measurement, 100 kHz
EP-5261	1 Channel Serial Communications, 232, 422, 485
EP-5311	1 Channel SSI Encoder, BCD or Gray-Code Format, 5/24 VDC
EP-5422	2 Channels PWM Output, Positive Logic, 24VDC, 2.0 A
EP-5442	2 Channels PWM Output, Positive Logic, 24VDC, 0.5 A
EP-5324	IO-Link Communication Module, 4 Channels
Power Feed Modules for Input Current Path	

Catalog Number	Module Description
EP-7631	Power Module, 1 Channel 24VDC Input Flow 10A
Power Feed Modules for Output Current Path	
EP-7641	Power Module, 1 Channel 24VDC Output Flow 10A
Safe Feed-input Modules	
EP-1901	1 Safe Feed-Input, 24 VDC
EP-1902	2 Safe Feed-Inputs, 24 VDC, Programmable Delay
EP-1922	2 Safe Feed-Inputs, 24 VDC
Potential Distribution Modules	
EP-711F	Power Module, 16 Channels 24VDC Potential Distribution +24 VDC from Input Current Path
EP-751F	Power Module, 16 Channels 24VDC Potential Distribution +24 VDC from Output Current Path
EP-700F	Power Module, 16 Channels 24VDC Potential Distribution Functional Earth
EP-710F	Power Module, 16 Channels 24VDC Potential Distribution +0VDC from Input Current Path
EP-750F	Power Module, 16 Channels 24VDC Potential Distribution +0VDC from Output Current Path

Release History

Catalog Number	Hardware Version	Firmware Version	Date	Comments
EPXMBE001-ACAE	02.00.00	02.03.00	Dec 19	Support for two newly introduced IO modules EP-1813 (Power Measurement module) and EP-5324 (IO-Link Communication Module) with only IPI update.
EPXMBE001-AAAE	01.00.00			
EPXMBE001-ACAE	02.00.00	02.03.00	Sep 19	<ul style="list-style-type: none"> - Following Emerson's acquisition of this product, changes have been made to apply appropriate branding and registration of the product with required certification agencies. No changes to material, process, form, fit or functionality. - Brand labeling Web Application to EMERSON. - Updates to webserver :- <ul style="list-style-type: none"> - 'Ordering data is removed from General information section of Emerson branded products. - Improved module parameter setting dialogue in web application. - Factory reset over a Modbus-Register possible.
EPXMBE001-AAAE	01.00.00			
EPXMBE001-ABAD	02.00.00	02.02.00	Oct 18	New features: <ul style="list-style-type: none"> - Reset button appears automatically when changes in parameter settings require a restart to take effect - Added display of slot numbers to list of compatible modules after selecting a firmware file in multi-update view. - Added HTTPS support and new coupler parameter 'HTTPS settings'. [Available with Hardware version "AB" & above only in combination with firmware version "AD" & above] - Added password policy and weak password check - default username and password will remain the same - New languages for Web Server available. Korean, French, Spanish, Portuguese and Italian - Support for EP-3664 Issue Fixes: <ul style="list-style-type: none"> - Fixed issue that live module unplug/replug sometimes corrupts I/O mapping
EPXMBE001-AAAD	01.00.00	02.02.00	Oct 18	

Catalog Number	Hardware Version	Firmware Version	Date	Comments
				- Fixed issue that re-installation attempt of language files sometimes causes an error message.
EPXMBE001-AAAC	01.00.00	02.01.00	Nov 17	Enhancements and updates to Web Application <ul style="list-style-type: none"> - Configuring an additional TCP Port doesn't require power cycle anymore & reconnection via additional TCP port is possible now - Web Application: <ul style="list-style-type: none"> a. Tooltips for Network Adaptor LEDs b. Improved arrangement of module parameters & general information c. Display of raw process data next to physical value d. Web application performance improved - Access of an illegal register address is causing a diagnostic - Serial number of coupler available via Modbus - Module black list detection - coupler rejects incompatible modules
EPXMBE001-AAAB	01.00.00	01.01.06	Sep 16	- Support for three new modules, EP-1804, EP-5261, and EP-5311 <ul style="list-style-type: none"> - Resolves a problem, see section <i>Problems Resolved by this Release</i> for more information
EPXMBE001-AAAA	01.00.00	01.01.06	Dec 15	Documentation update only, added known issues
EPXMBE001-AAAA	01.00.00	01.01.06	Nov 15	Initial Release

Important Product Information for this Release

Updates

This is to include support for 2 newly introduced IO modules namely EP-1813 (Power Measurement module) and EP-5324 (IO-Link Communication Module). Note that the below upgrade kit is put on web with only change in IPI document. The product may be upgraded in the field using the Web firmware upgrade kit, which can be downloaded from <https://www.emerson.com/Industrial-Automation-Controls/support>.

Modules	Hardware Version	Firmware Version	Upgrade Kit
EPXMBE001-AAAE	01.00.00	02.03.00	For HW version -AA[01.00.00], use EPXMBE001-0007669-02_03_00-1.zip which consists of <ol style="list-style-type: none"> 1) EPXMBE001-0007669-02_03_00-1.bsc 2) FW_upgrade_procedure 3) IPI-GFK-2966F
EPXMBE001-ACAE	02.00.00	02.03.00	For HW version -AB & above versions [02.00.00], use EPXMBE001-0007675-02_03_00-2.zip which consists of <ol style="list-style-type: none"> 1) EPXMBE001-0007675-02_03_00-2.bsc 2) FW_upgrade_procedure 3) IPI-GFK-2966F

Functional Compatibility

HW Index [Ver]	FW Index [Ver]				
	AA [01.01.06]	AB [02.00.00]	AC [02.01.00]	AD [02.02.00]	AE [02.03.00]
AA [01.00.00]	OK	OK	OK	OK	OK ¹⁾
AB [02.00.00]	NO	OK	OK	OK	OK ²⁾
AC [02.00.00]	NO	OK	OK	OK	OK ²⁾
1) For HW version AA[01.00.00], latest compatible FW file is EPXMBE001-0007669-02_03_00-1.bsc. This file cannot be used with Hardware version[02.00.00] 2) For HW version AB & AC [02.00.00], latest compatible FW file is EPXMBE001-0007675-02_03_00-2.bsc file. This file cannot be used with Hardware version[01.00.00]					

Problems Resolved by this Release

None - Documentation update only

New Features and Enhancements

Subject	Description
Enhancements	Support for two newly introduced IO modules EP-1813 (Power Measurement module) and EP-5324 (IO-Link Communication Module).

Known Restrictions and Open Issues

Subject	Description
Channel diagnostics faults are reported during hot-swap of the modules.	During hot-swap of an I/O module, the network adapter may report additional channel diagnostics messages in addition to the expected <i>Loss of Module</i> or <i>Addition of Module</i> fault.
Behavior during hot removal when similar modules are configured consecutively	Where similar modules are configured consecutively in the remote I/O node, a shift in input data occurs when one of the consecutive modules is pulled out from a node. For example, when there are 6 RTD modules EP-3704, configured consecutively in the node, slots 1 - 6, on hot-removal of the module from slot 4, data from modules 5 and 6 would be reflected on variables configured for slot 4 and 5, respectively, with <i>Loss of Module</i> reported for slot 6.

Operational Notes

Subject	Description
Output behavior during hotswap	During hot insertion or removal of IO modules, a transient Loss of Power up-to 500 ms may occur on the network adapter and IO modules, during which all of the outputs may drop to zero. This system behavior should be verified against the application requirements before hot insertion or removal of the IO module is done.

Product Documentation

RSTi-EP Slice I/O Module User Manual (GFK-2958)

RSTi-EP Slice I/O Functional Safety Module User Manual (GFK-2956)

Technical Support & Contact Information:

Home link: <http://www.Emerson.com/Industrial-Automation-Controls>

Knowledge Base: <https://www.emerson.com/Industrial-Automation-Controls/support>

Note: If the product is purchased through an Authorized Channel Partner, please contact the seller directly for any support.

Emerson reserves the right to modify or improve the designs or specifications of the products mentioned in this manual at any time without notice. Emerson does not assume responsibility for the selection, use or maintenance of any product. Responsibility for proper selection, use and maintenance of any Emerson product remains solely with the purchaser.

© 2019 Emerson. All rights reserved.

Emerson Terms and Conditions of Sale are available upon request. The Emerson logo is a trademark and service mark of Emerson Electric Co. All other marks are the property of their respective owners.

