

Operating Instructions

iTEMP TMT31

Temperature transmitter



Table of contents

1	About this document	4	9	Diagnostics and troubleshooting ...	23
1.1	Document function	4	9.1	General troubleshooting	23
1.2	Safety Instructions (XA)	4	9.2	Diagnostic information via communication interface	24
1.3	Symbols used	4	9.3	Active diagnostics	24
1.4	Tool symbols	6	9.4	Overview of diagnostic events	24
1.5	Documentation	6	9.5	Firmware history	25
2	Basic safety instructions	7	10	Maintenance	25
2.1	Requirements for the personnel	7	11	Repair	26
2.2	Intended use	7	11.1	General notes	26
2.3	Operational safety	7	11.2	Spare parts	26
3	Incoming acceptance and product identification	8	11.3	Return	26
3.1	Incoming acceptance	8	11.4	Disposal	26
3.2	Product identification	8	12	Accessories	26
3.3	Scope of delivery	9	12.1	Device-specific accessories	26
3.4	Certificates and approvals	9	12.2	Communication-specific accessories	27
3.5	Transport and storage	9	12.3	Service-specific accessories	27
4	Mounting	10	12.4	System components	28
4.1	Mounting requirements	10	13	Technical data	29
4.2	Mounting the device	10	13.1	Input	29
4.3	Post-mounting check	12	13.2	Output	29
5	Electrical connection	13	13.3	Power supply	30
5.1	Connecting requirements	13	13.4	Performance characteristics	30
5.2	Quick wiring guide	13	13.5	Environment	32
5.3	Connecting the sensor input	14	13.6	Mechanical construction	33
5.4	Connecting the transmitter	14	13.7	Certificates and approvals	33
5.5	Post-connection check	15	13.8	Documentation	34
6	Operation options	16			
6.1	Overview of operation options	16			
6.2	Structure and function of the operating menu	16			
6.3	Access to the operating menu via the operating tool	17			
7	System integration	20			
7.1	Overview of device description files	20			
8	Commissioning	21			
8.1	Post-installation check	21			
8.2	Switching on the transmitter	21			
8.3	Configuring the measuring device	21			
8.4	Protecting settings from unauthorized access .	22			

1 About this document

1.1 Document function

These Operating Instructions contain all the information that is required in various phases of the life cycle of the device: from product identification, incoming acceptance and storage, to mounting, connection, operation and commissioning through to troubleshooting, maintenance and disposal.

1.2 Safety Instructions (XA)

When using in hazardous areas, compliance with national regulations is mandatory. Separate Ex-specific documentation is provided for measuring systems that are used in hazardous areas. This documentation is an integral part of these Operating Instructions. The installation specifications, connection data and safety instructions it contains must be strictly observed! Make sure that you use the right Ex-specific documentation for the right device with approval for use in hazardous areas! The number of the specific Ex documentation (XA...) is provided on the nameplate. If the two numbers (on the Ex documentation and the nameplate) are identical, then you may use this Ex-specific documentation.

1.3 Symbols used

1.3.1 Safety symbols

DANGER

This symbol alerts you to a dangerous situation. Failure to avoid this situation will result in serious or fatal injury.

WARNING

This symbol alerts you to a dangerous situation. Failure to avoid this situation can result in serious or fatal injury.



CAUTION



This symbol alerts you to a dangerous situation. Failure to avoid this situation can result in minor or medium injury.

NOTICE













This symbol contains information on procedures and other facts which do not result in personal injury.

1.3.2 Electrical symbols



Symbol	Meaning
	Direct current
	Alternating current
	Direct current and alternating current

Symbol	Meaning
	Ground connection A grounded terminal which, as far as the operator is concerned, is grounded via a grounding system.
	Protective Earth (PE) A terminal which must be connected to ground prior to establishing any other connections. The ground terminals are situated inside and outside the device: <ul style="list-style-type: none"> ▪ Inner ground terminal: Connects the protective earth to the mains supply. ▪ Outer ground terminal: Connects the device to the plant grounding system.



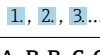

1.3.3 Symbols for certain types of information

Symbol	Meaning
	Permitted Procedures, processes or actions that are permitted.
	Preferred Procedures, processes or actions that are preferred.
	Forbidden Procedures, processes or actions that are forbidden.
	Tip Indicates additional information.
	Reference to documentation.
	Reference to page.
	Reference to graphic.
	Notice or individual step to be observed.
	Series of steps.
	Result of a step.
	Help in the event of a problem.
	Visual inspection.

1.3.4 Symbols in graphics

Symbol	Meaning	Symbol	Meaning
1, 2, 3,...	Item numbers		Series of steps
A, B, C, ...	Views	A-A, B-B, C-C, ...	Sections
	Hazardous area		Safe area (non-hazardous area)

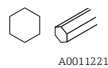
1.4 Tool symbols

Symbol	Meaning
 A0011220	Flat-blade screwdriver
 A0011219	Phillips head screwdriver
 A0011221	Allen key
 A0011222	Open-ended wrench
 A0013442	Torx screwdriver

1.5 Documentation

Document	Purpose and content of the document
Technical Information TI01613T	Planning aid for your device The document contains all the technical data on the device and provides an overview of the accessories and other products that can be ordered for the device.
Brief Operating Instructions KA01540T	Guide that takes you quickly to the 1st measured value The Brief Operating Instructions contain all the essential information from incoming acceptance to initial commissioning.
Description of Device Parameters GP01182T	The document serves as a reference for parameters: it provides a detailed explanation for each individual parameter in the operating menu.



The document types listed are available:

In the Download Area of the Endress+Hauser Internet site: www.endress.com → Download

2 Basic safety instructions

2.1 Requirements for the personnel

The personnel performing installation, commissioning, diagnostics and maintenance must satisfy the following requirements:

- ▶ Trained, qualified specialists must be suitably qualified to perform this function and task
- ▶ Are authorized by the plant owner/operator
- ▶ Are familiar with federal/national regulations
- ▶ They must have read and understood the instructions in the manual, supplementary documentation and certificates (depending on the application) prior to starting work
- ▶ They must follow instructions and comply with basic conditions

The operating personnel must satisfy the following requirements:

- ▶ They must be suitably trained and authorized by the plant operator to meet the requirements of the task
- ▶ They must follow the instructions in this manual

2.2 Intended use

The device is a universal and configurable temperature transmitter with a sensor input for resistance thermometers (RTD). The head transmitter version of the device is intended for mounting in a terminal head (flat face) as per DIN EN 50446. It is also possible to mount the device on a DIN rail using the optional DIN rail clip.

If the device is used in a manner not specified by the manufacturer, the protection provided by the device may be impaired.

The manufacturer is not liable for damage caused by using the device incorrectly or for purposes for which it was not intended.

2.3 Operational safety

- ▶ Operate the device only if it is in proper technical condition, free from errors and faults.
- ▶ The operator is responsible for interference-free operation of the device.

Hazardous area

To eliminate a danger for persons or for the facility when the device is used in the hazardous area (e.g. explosion protection or safety equipment):

- ▶ Based on the technical data on the nameplate, check whether the ordered device is permitted for the intended use in the hazardous area. The nameplate can be found on the side of the transmitter housing.
- ▶ Observe the specifications in the separate supplementary documentation that is an integral part of these instructions.

Electromagnetic compatibility

The measuring system complies with the general safety requirements as per EN 61010-1, the EMC requirements as per the IEC/EN 61326 series and the NAMUR recommendations NE 21.

NOTICE

- ▶ The device must be powered only by a power unit that operates using a limited-energy circuit in accordance with UL/EN/IEC 61010-1, Section 9.4 and the requirements in Table 18.

3 Incoming acceptance and product identification

3.1 Incoming acceptance

1. Unpack the temperature transmitter carefully. Is the packaging or content free from damage?
 - ↳ Damaged components must not be installed as the manufacturer can otherwise not guarantee compliance with the original safety requirements or the material resistance, and can therefore not be held responsible for any resulting damage.
2. Is the delivery complete or is anything missing? Check the scope of delivery against your order.
3. Does the nameplate match the ordering information on the delivery note?
4. Are the technical documentation and all other necessary documents provided? If applicable: are the Safety Instructions (e.g. XA) for hazardous areas provided?

 If one of these conditions is not satisfied, contact your Sales Center.

3.2 Product identification

The following options are available for identification of the device:

- Nameplate specifications
- Extended order code with breakdown of the device features on the delivery note
- Enter the serial number from the nameplate in the *W@M Device Viewer* (www.endress.com/deviceviewer): all data relating to the device and an overview of the Technical Documentation supplied with the device are displayed.
- Enter the serial number on the nameplate into the *Endress+Hauser Operations App* or scan the 2-D matrix code (QR code) on the nameplate with the *Endress+Hauser Operations App*: all the information about the device and the technical documentation pertaining to the device is displayed.

3.2.1 Nameplate

The right device?

Compare and check the data on the nameplate of the device against the requirements of the measuring point:

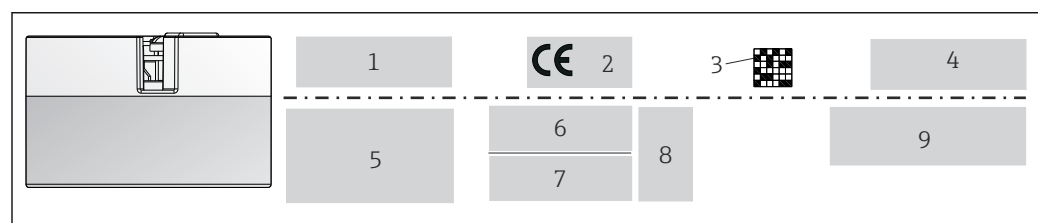

A0046937

 1 Nameplate of the head transmitter (example, Ex version)

- 1 Power supply, current consumption, ambient temperature
- 2 Firmware version, logos
- 3 Data Matrix 2D code
- 4 2 lines for the TAG name
- 5 Approval information in hazardous area with number of the relevant Ex documentation
- 6 Serial number and extended order code
- 7 Manufacturer identification
- 8 Optional approval symbols
- 9 Manufacturer name and order code

3.2.2 Name and address of manufacturer

Name of manufacturer:	Endress+Hauser Wetzler GmbH + Co. KG
Address of manufacturer:	Obere Wank 1, D-87484 Nesselwang or www.endress.com

3.3 Scope of delivery

The scope of delivery of the device comprises:

- Temperature transmitter
- Mounting material (head transmitter), optional
- Printed copy of Brief Operating Instructions in English
- Additional documentation for devices which are suitable for use in the hazardous area (ATEX, CSA) , such as Safety Instructions (XA...)

3.4 Certificates and approvals

The device left the factory in a safe operating condition. The device complies with the requirements of the standards EN 61010-1 "Safety Requirements for Electrical Equipment for Measurement, Control, and Laboratory Use" and with the EMC requirements as per the IEC/EN 61326 21 series + NAMUR recommendation NE 21.

3.5 Transport and storage

Carefully remove all the packaging material and protective covers that are part of the transported package.

 For dimensions and operating conditions, see "Mechanical construction" section.

When storing and transporting the device, pack it so that it is reliably protected against impact. The original packaging offers the best protection.

Storage temperature

Head transmitter: -50 to +100 °C (-58 to +212 °F)

4 Mounting

4.1 Mounting requirements

4.1.1 Dimensions

The dimensions of the device are provided in the "Technical data" section .

4.1.2 Mounting location

In the terminal head, flat face, as per DIN EN 50446, direct mounting on insert with cable entry (middle hole 7 mm).

i Make sure there is enough space in the terminal head!

i It is also possible to mount the head transmitter on a DIN rail as per IEC 60715 using the DIN rail clip accessory.

Information about the conditions (such as the ambient temperature, degree of protection, climate class etc.) that must be present at the installation point so that the device can be mounted correctly is provided in the "Technical data" section .

When using the device in hazardous areas, the limit values of the certificates and approvals must be observed (see Ex Safety Instructions).

4.2 Mounting the device

A Phillips head screwdriver is required to mount the head transmitter:

- Maximum torque for securing screws = 1 Nm (¾ foot-pound), screwdriver: Pozidriv Z2
- Maximum torque for screw terminals = 0.35 Nm (¼ foot-pound), screwdriver: Pozidriv Z1

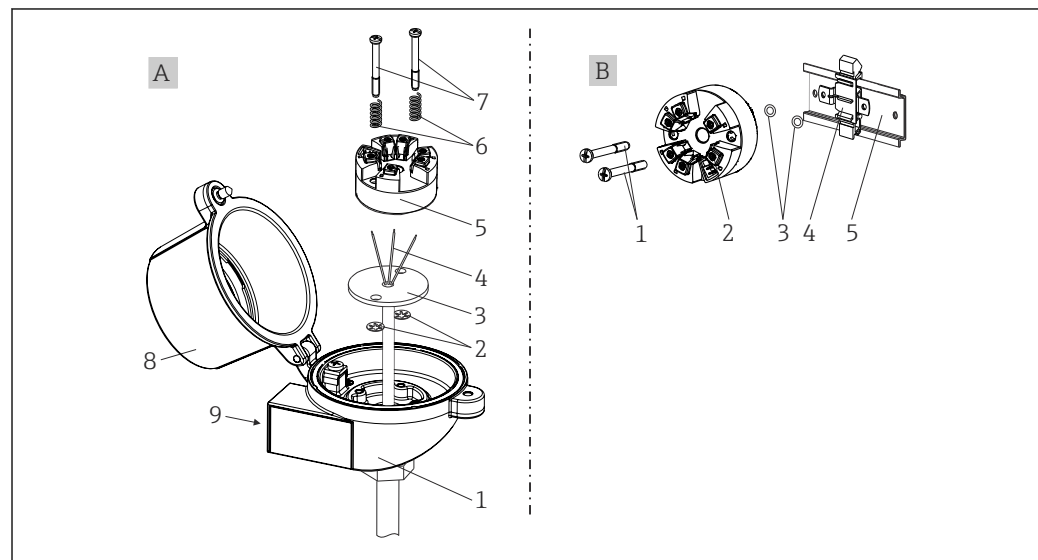

2 Head transmitter mounting

A	Mounting in a terminal head (terminal head flat face as per DIN 43729)
1	Terminal head
2	Circlips
3	Insert

A	Mounting in a terminal head (terminal head flat face as per DIN 43729)
4	Connection wires
5	Head transmitter
6	Mounting springs
7	Mounting screws
8	Terminal head cover
9	Cable entry

Procedure for mounting in a terminal head, Item A:

1. Open the terminal head cover (8) on the terminal head.
2. Guide the connection wires (4) of the insert (3) through the center hole in the head transmitter (5).
3. Fit the mounting springs (6) on the mounting screws (7).
4. Guide the mounting screws (7) through the side boreholes of the head transmitter and the insert (3). Then fix both mounting screws with the snap rings (2).
5. Then tighten the head transmitter (5) along with the insert (3) in the terminal head.
6. After wiring, close the terminal head cover (8) tightly again.

B	Mounting on DIN rail (DIN rail as per IEC 60715)
1	Mounting screws
2	Head transmitter
3	Circlips
4	DIN rail clip
5	DIN rail

4.2.1 Mounting typical of North America

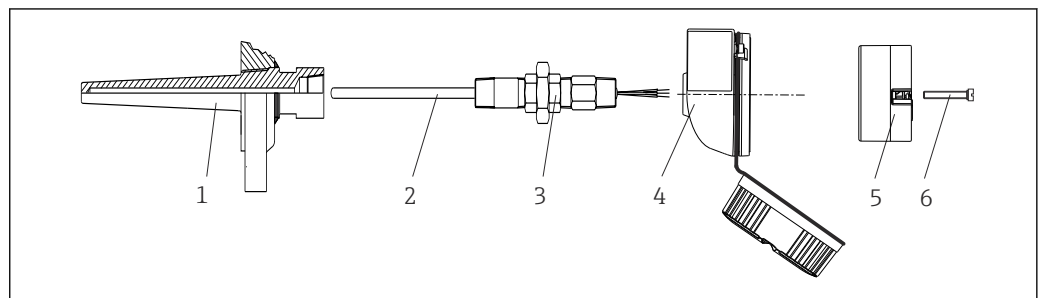

A0008520

3 Head transmitter mounting

- 1 Thermowell
- 2 Insert
- 3 Adapter, coupling
- 4 Terminal head
- 5 Head transmitter
- 6 Mounting screws

Structure of thermometer with RTD sensors and head transmitter:

1. Fit the thermowell (1) on the process pipe or the container wall. Secure the thermowell according to the instructions before the process pressure is applied.
2. Fit the necessary neck tube nipples and adapter (3) on the thermowell.

3. Make sure sealing rings are installed if such rings are needed for harsh environmental conditions or special regulations.
4. Guide the mounting screws (6) through the lateral bores of the head transmitter (5).
5. Position the head transmitter (5) in the terminal head (4) in such a way that the power supply lines (terminals 1 and 2) point to the cable entry.
6. Using a screwdriver, screw down the head transmitter (5) in the terminal head (4).
7. Guide the connection wires of the insert (3) through the lower cable entry of the terminal head (4) and through the middle hole in the head transmitter (5). Wire the connection wires up to the transmitter .
8. Screw the terminal head (4), with the integrated and wired head transmitter, onto the ready-mounted nipple and adapter (3).

NOTICE

The terminal head cover must be secured properly to meet the requirements for explosion protection.

- ▶ After wiring, securely screw the terminal head cover back on.

4.3 Post-mounting check

After installing the device, always perform the following final checks:

Device condition and specifications	Notes
Are the device, the connections and connecting cables free of damage (visual inspection)?	-
Do the ambient conditions match the device specification (e.g. ambient temperature, measuring range, etc.)?	See the 'Technical data' section
Have connections been established correctly and with the specified torque?	-

5 Electrical connection



⚠ CAUTION

- ▶ Switch off the power supply before installing or connecting the device. Non-compliance may result in the destruction of parts of the electronics.
- ▶ Do not occupy the CDI connection. An incorrect connection can destroy the electronics.

5.1 Connecting requirements

A Phillips head screwdriver is required to wire the head transmitter with screw terminals. The push-in terminal version can be wired without any tools.

Proceed as follows to wire a mounted head transmitter:

1. Open the cable gland and the housing cover on the terminal head or the field housing.
2. Feed the cables through the opening in the cable gland.
3. Connect the cables as shown in →  13. If the head transmitter is fitted with push-in terminals, pay particular attention to the information in the "Connecting to push-in terminals" section. →  14
4. Tighten the cable gland again and close the housing cover.

In order to avoid connection errors always follow the instructions in the post-connection check section before commissioning!

5.2 Quick wiring guide

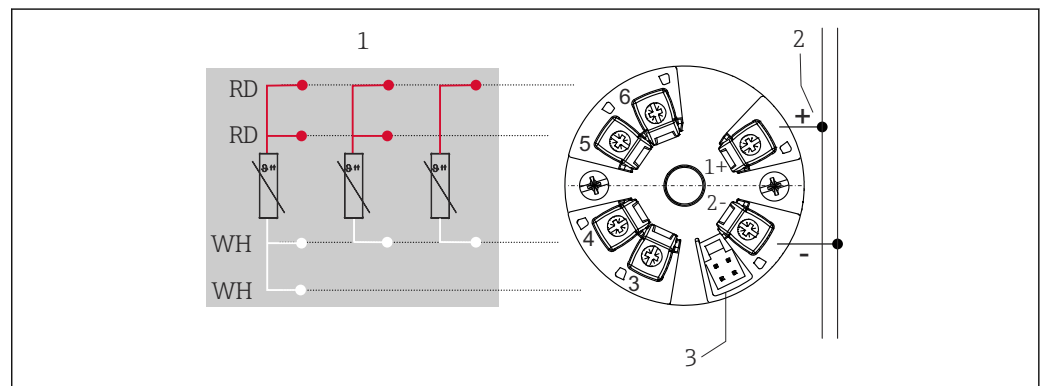

 4 Terminal assignment of head transmitter

- 1 RTD sensor input: 4-, 3- and 2-wire
- 2 Power supply
- 3 CDI interface

NOTICE

- ▶  ESD - Electrostatic discharge. Protect the terminals from electrostatic discharge. Non-compliance may result in the destruction or malfunction of parts of the electronics.

Maximum torque for screw terminals = 0.35 Nm ($\frac{1}{4}$ lbf ft), screwdriver: Pozidriv Z1

5.3 Connecting the sensor input

5.3.1 Connecting to push-in terminals

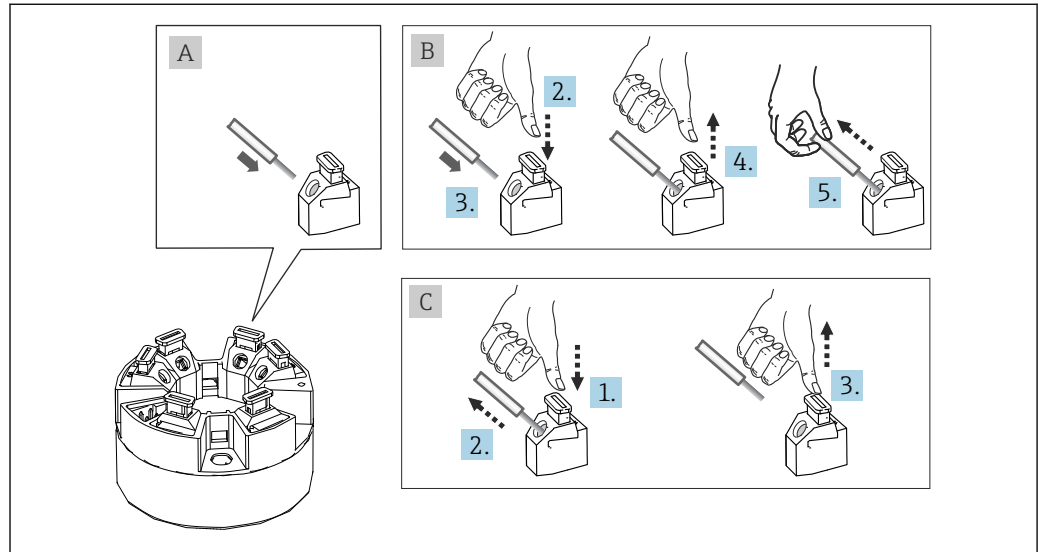

5 Push-in terminal connection, using the example of a head transmitter

Item A, solid wire:

1. Strip wire end. Min. stripping length 10 mm (0.39 in).
2. Insert the wire end into the terminal.
3. Pull the wire gently to ensure it is connected correctly. Repeat from step 1 if necessary.

Item B, fine-strand wire without ferrule:

1. Strip wire end. Min. stripping length 10 mm (0.39 in).
2. Press down on the lever opener.
3. Insert the wire end into the terminal.
4. Release lever opener.
5. Pull the wire gently to ensure it is connected correctly. Repeat from step 1 if necessary.

Item C, releasing the connection:

1. Press down on the lever opener.
2. Remove the wire from the terminal.
3. Release lever opener.

5.4 Connecting the transmitter

i Cable specification

The instrument cable is not subject to special requirements, such as shielding requirements for example.

Please also observe the general procedure on → 13.

- i** The terminals for the power supply (1+ and 2-) are protected against reverse polarity.
- Cable cross-section, see the "Technical data", → 30

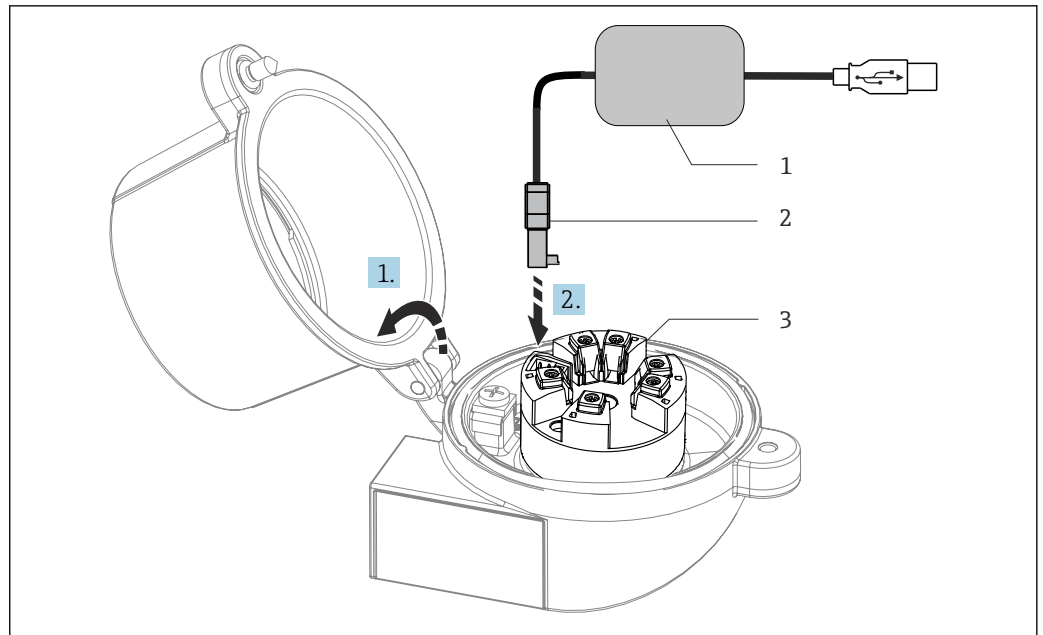

A0047087

6 Fitting the CDI connector of the configuration kit for configuration, visualization and maintenance of the head transmitter via PC and configuration software

- 1 Configuration kit with USB port
- 2 CDI connector
- 3 Installed head transmitter with CDI interface

5.5 Post-connection check

Device condition and specifications	Notes
Are the device or cables undamaged (visual check)?	--
Electrical connection	Notes
Does the supply voltage match the specifications on the nameplate?	Head transmitter: $U = \text{e.g. } 10 \text{ to } 36 \text{ V}_{\text{DC}}$
Do the mounted cables have adequate strain relief?	--
Are the power supply and signal cables correctly connected?	→ 13
Are all the screw terminals well tightened and have the connections of the push-in terminals been checked?	--
Are all cable entries mounted, firmly tightened and leak-tight?	--

6 Operation options

6.1 Overview of operation options

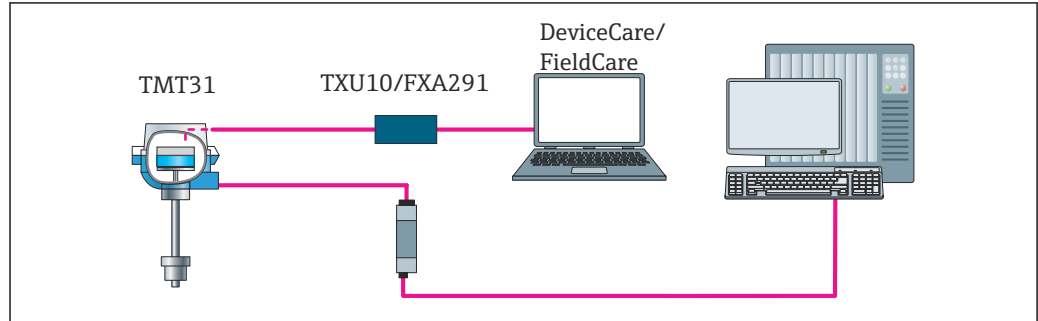

A0046628

7 Operation options for the transmitter via the CDI interface

6.2 Structure and function of the operating menu

6.2.1 Structure of the operating menu

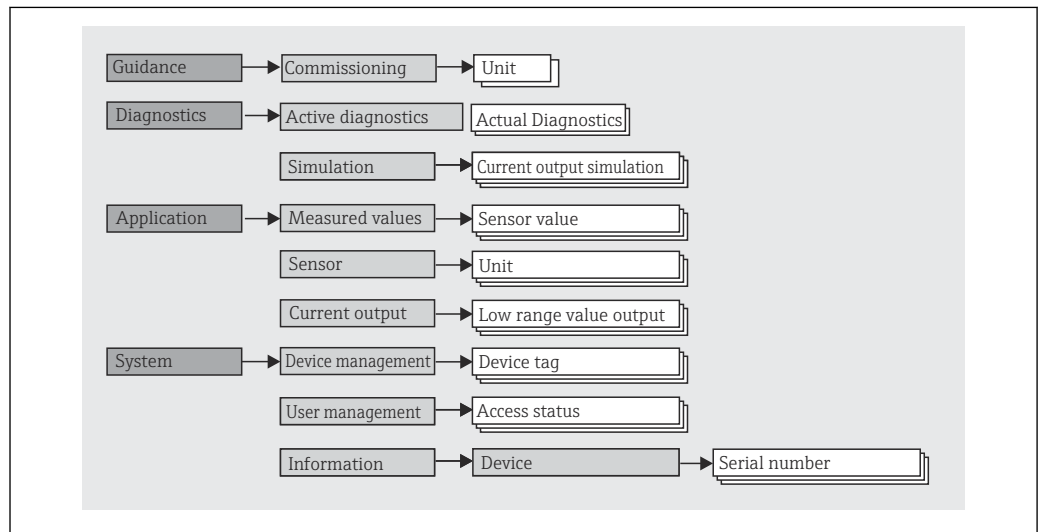

A0046999

User roles

Navigation System → User management

The role-based access concept consists of two hierarchical levels for the user and presents the various user roles with defined read/write authorizations derived from the NAMUR shell model.

- **Operator**
The plant operator can only change settings that do not affect the application - and particularly the measuring path - and simple, application-specific functions that are used during operation. The operator is able to read all the parameters, however.
- **Maintenance**
The **Maintenance** user role refers to configuration situations: commissioning and process adaptations as well as troubleshooting. It allows the user to configure and modify all available parameters. In contrast to the **Operator** user role, in the **Maintenance** role the user has read and write access to all the parameters.
- **Changing the user role**
A user role - and therefore existing read and write authorization - is changed by selecting the desired user role (already pre-selected depending on the operating tool) and entering the correct password when subsequently prompted. When a user logs out, system access always returns to the lowest level in the hierarchy. A user logs out by actively selecting the logout function when operating the device.
- **As-delivered state**
The **Operator** user role is not enabled when the device is delivered from the factory, i.e. the **Maintenance** role is the lowest level in the hierarchy ex-works. This state makes it possible to commission the device and make other process adaptations without having to enter a password. Afterwards, a password can be assigned for the **Maintenance** user role to protect this configuration. If the option *Configuration locked when delivered* was selected during device configuration, the device is set to the **Operator** user role when delivered. It is therefore not possible to change the configuration. The delivery password stored can be reset and reassigned.
- **Password**
The **Maintenance** user role can assign a password in order to restrict access to device functions. This activates the **Operator** user role, which is now the lowest hierarchy level where the user is not asked to enter a password. The password can only be changed or disabled in the **Maintenance** user role.

Submenus

Menu	Typical tasks	Content/meaning
"Diagnostics"	Troubleshooting: <ul style="list-style-type: none"> ▪ Diagnosing and eliminating process errors. ▪ Error diagnostics in difficult cases. ▪ Interpretation of device error messages and correcting associated errors. 	Contains all parameters for detecting and analyzing errors: <ul style="list-style-type: none"> ▪ Active diagnostics Displays the error message that is currently active ▪ "Current output simulation" submenu Used to simulate output values.
"Application"	Commissioning: <ul style="list-style-type: none"> ▪ Configuration of the measurement. ▪ Configuration of data processing (scaling, linearization, etc.). ▪ Configuration of the analog measured value output. Tasks during operation: Reading measured values.	Contains all the parameters for commissioning: <ul style="list-style-type: none"> ▪ "Measured values" submenu Contains all the current measured values ▪ "Sensor" submenu Contains all the parameters for configuring the measurement ▪ "Output" submenu Contains all the parameters for configuring the analog current output
"System"	Tasks that require detailed knowledge of the system administration of the device: <ul style="list-style-type: none"> ▪ Optimum adaptation of the measurement for system integration. ▪ User and access administration, password control ▪ Information for device identification 	Contains all higher-level device parameters that are assigned to system, device and user management. <ul style="list-style-type: none"> ▪ "Device management" submenu Contains parameters for general device management ▪ "User management" submenu Parameters for access authorization, password assignment, etc. ▪ "Information" submenu Contains all the parameters for the unique identification of the device

6.3 Access to the operating menu via the operating tool

The Endress+Hauser FieldCare and DeviceCare operating tools are available to download (<https://www.software-products.endress.com>) or can be found on the data storage medium, which you can obtain from your local Endress+Hauser Sales Center.

6.3.1 DeviceCare

Function scope

DeviceCare is a free configuration tool for Endress+Hauser devices. It supports devices with the following protocols, provided a suitable device driver (DTM) is installed: HART, PROFIBUS, FOUNDATION Fieldbus, Ethernet/IP, Modbus, CDI, ISS, IPC and PCP. The target group comprises customers without a digital network in plants and service centers as well as Endress+Hauser service technicians. The devices can be connected directly via a modem (point-to-point) or a bus system. DeviceCare is fast, easy and intuitive to use. It can run on a PC, laptop or tablet with a Windows operating system.

Source for device description files

See information in the "System integration" section →  20

Establishing a connection

Example: CDI communication kit TXU10 and FXA291 (USB)

1. Make sure that the DTM library is updated for all the connected devices (e.g. FXA29x, TMTxy).
2. Start DeviceCare and connect the device via the **Automatic** button.
 - ↳ The device is detected automatically.

 When transmitting the device parameters following offline parameter configuration, the password for **Maintenance** must first be entered in the **System -> User administration** menu, if specified.

6.3.2 FieldCare

Function scope

FDT/DTM-based plant asset management tool from Endress+Hauser. It can configure all smart field devices in a system and helps you manage them. By using the status information, it is also a simple but effective way of checking their status and condition. Access is via the HART® protocol, CDI (= Endress+Hauser Common Data Interface). It also supports devices with the following protocols, provided a suitable device driver (DTM) is installed: PROFIBUS, FOUNDATION Fieldbus.

Typical functions:

- Transmitter parameter configuration
- Loading and saving of device data (upload/download)
- Documentation of the measuring point
- Visualization of the measured value memory (line recorder) and event logbook

 For details, see Operating Instructions BA027S/04/xx and BA059AS/04/xx

Source for device description files

See information →  20

Establishing a connection

Example: CDI communication kit TXU10 or FXA291 (USB)

1. Make sure that the DTM library is updated for all the connected devices (e.g. FXA29x, TMTxy).
2. Start FieldCare and create a project.

3. Right-click **Host PC** Add device...
 - ↳ The **Add new device** window opens.
 4. Select the **CDI Communication FXA291** option from the list and press **OK** to confirm.
 5. Double-click **CDI Communication FXA291** DTM.
 - ↳ Check whether the correct modem is connected to the serial interface connection.
 6. Right-click **CDI Communication FXA291** and in the context menu select the **Create network** option.
 - ↳ The connection to the device is established.
-  When transmitting the device parameters following offline parameter configuration, the password for **Maintenance** must first be entered in the **System -> User administration** menu, if specified.

7 System integration

7.1 Overview of device description files

Version data for the device

Firmware version	01.01.zz	<ul style="list-style-type: none"> ▪ On the title page of the manual ▪ On the nameplate ▪ Firmware version parameter System → Information → Device
------------------	----------	--

The suitable device driver software (DD/DTM) for the individual operating tools can be acquired from various sources:



- www.endress.com → Downloads → Search field: Software → Software type: Device driver
- www.endress.com → Products: individual product page, e.g. TMTxy → Documents / Manuals / Software: Device Type Manager (DTM).

The Endress+Hauser FieldCare and DeviceCare operating tools are available to download (<https://www.software-products.endress.com>) or can be found on the data storage medium, which you can obtain from your local Endress+Hauser Sales Center.

8 Commissioning

8.1 Post-installation check

Before commissioning the measuring point make sure that all final checks have been carried out:

- "Post-installation check" checklist →  10
- "Post-connection check" checklist →  13

8.2 Switching on the transmitter

Once you have completed the post-connection checks, switch on the supply voltage. The transmitter performs a number of internal test functions after power-up.

The device works after approx. 5 seconds. Normal measuring mode commences as soon as the switch-on procedure is completed.

8.3 Configuring the measuring device

The starting point is in the **Guidance** menu. Parameter settings that require specific access permissions may be disabled (lock symbol). In order to use a device for the designated application, the first step is to commission the device.

Navigation  **Guidance → Commissioning**

The following parameters can be configured:

Unit
 Sensor type
 Connection type
 2-wire compensation
 Lower range value output
 Upper range value output
 Failure mode

In the final section, a password can be defined for the "Maintenance" user role. This is strongly recommended to protect the device against unauthorized access. The following steps describe how to configure a password for the "Maintenance" role for the first time.

Navigation  **System → User management**

Access status
 Logout
 Delete password

1. In the "Access status" field, the **Maintenance** role appears with the two entry fields **Logout** and **Delete password**.
2. **Logout** function:
 Enable the **Logout** entry field.
 - ↳ The **Operator** role appears in the "Access status" field. The **Enter access code** entry field is displayed.
3. To return to the **Maintenance** role, enter a four-digit access code, which you have already defined, in this entry field.
 - ↳ The **Maintenance** role appears in the "Access status" field.

4. **Delete password** function:
Enable the **Delete password** entry field.
5. In the **Define software write protection code** entry field, enter a user-defined password that meets the specifications in the online help.
 - ↳ The startup screen as described in Step 1 appears.

Once the password has been entered successfully, parameter changes, particularly those that are needed for commissioning, process adaptation/optimization and troubleshooting, can only be implemented in the **Maintenance** user role and if the password is entered successfully.

8.4 Protecting settings from unauthorized access

8.4.1 Software locking

By assigning a password for the **Maintenance** user role, it is possible to restrict access authorization and protect the device against unauthorized access.

The parameters are also protected against modification by logging out of the **Maintenance** user role and switching to the **Operator** role. A lock symbol appears.

To disable the write protection, the user must log on with the **Maintenance** user role via the relevant operating tool.



User role concept →  16

9 Diagnostics and troubleshooting

9.1 General troubleshooting

Always start troubleshooting with the checklists below if faults occur after startup or during operation. The checklists take you directly (via various queries) to the cause of the problem and the appropriate remedial measures.

 Due to its design, the device cannot be repaired. However, it is possible to send the device in for examination. See the information in the "Return" section.

General faults

Fault	Possible cause	Remedial action
Device does not respond.	Supply voltage does not match the voltage specified on the nameplate.	Check the voltage at the transmitter directly using a voltmeter and correct.
	Connecting cables are not in contact with the terminals.	Ensure electrical contact between the cable and the terminal.
	Electronics module is defective.	Replace the device.
Output current < 3.6 mA	Signal cable is not wired correctly.	Check wiring.
	Electronics module is defective.	Replace the device.
	'Low Alarm' failure current is set	Set the failure current to 'High Alarm'.

Error messages in the configuration software





→  24

Application errors without status messages for RTD sensor connection

Fault	Possible cause	Remedial action
Measured value is incorrect/ inaccurate	Incorrect sensor orientation.	Install the sensor correctly.
	Heat conducted by sensor.	Observe the installed length of the sensor.
	Device programming is incorrect (number of wires).	Change the Connection type device function.
	Device programming is incorrect (scaling).	Change scaling.
	Incorrect RTD configured.	Change the Sensor type device function.
	Sensor connection.	Check that the sensor is connected correctly.
	The cable resistance of the sensor (2-wire) was not compensated.	Compensate the cable resistance.
	Offset incorrectly set.	Check offset.
Failure current (≤ 3.6 mA or ≥ 21 mA)	Faulty sensor.	Check the sensor.
	RTD connected incorrectly.	Connect the connecting cables correctly (terminal diagram).
	Device programming is incorrect (e.g. number of wires).	Change the Connection type device function.
	Incorrect programming.	Incorrect sensor type set in the Sensor type device function. Set the correct sensor type.

9.2 Diagnostic information via communication interface

Status signals

Letter/ symbol ¹⁾	Event category	Meaning
F 	Operating error	An operating error has occurred.
C 	Service mode	The device is in the service mode (e.g. during a simulation).
S 	Out of specification	The device is being operated outside its technical specifications (e.g. during warm-up or cleaning processes).
M 	Maintenance required	Maintenance is required.
N -	Not categorized	

1) As per NAMUR NE107

Diagnostic behavior

Alarm	The measurement is interrupted. The signal outputs adopt the defined alarm condition. A diagnostic message is generated.
Warning	The device continues to measure. A diagnostic message is generated.
Disabled	The diagnosis is completely disabled even if the device is not recording a measured value.

9.3 Active diagnostics

If several diagnostic messages are pending at the same time, only the current diagnostic message is displayed. The status signal dictates the priority in which the diagnostic messages are displayed. The following order of priority applies: F, C, S, M.

9.4 Overview of diagnostic events

Each diagnostic event is assigned a certain event level at the factory.

Diagnostic number	Short text	Remedy instructions	Status signal [from the factory]	Diagnostic behavior [from the factory]
Diagnostic of sensor				
041	Sensor interrupted	1. Check electrical connection 2. Replace sensor 1 3. Check connection type	F	Alarm
043	Short circuit	1. Check electrical connection 2. Check sensor 3. Replace sensor or cable	F	Alarm
047	Sensor limit reached	1. Check sensor 2. Check process conditions	S	Warning
Diagnostic of electronic				
201	Electronics faulty	1. Restart device 2. Replace electronics	F	Alarm

Diagnostic number	Short text	Remedy instructions	Status signal [from the factory]	Diagnostic behavior [from the factory]
Diagnostic of configuration				
402	Initialization active	Initialization in progress, please wait	C	Warning
410	Data transfer failed	1. Check connection 2. Repeat data transfer	F	Alarm
411	Up-/download active	Up-/download in progress, please wait	C	Warning
435	Linearization faulty	Check linearization	F	Alarm
485	Process variable simulation active	Deactivate simulation	M	Warning
491	Output simulation	Deactivate simulation	C	Warning
531	Factory adjustment missing	1. Contact service organization 2. Replace device	F	Alarm
537	Configuration	1. Check device configuration 2. Up- and download new configuration	F	Alarm
537	Configuration	Check current output configuration	F	Alarm
Diagnostic of process				
801	Supply voltage too low	Increase supply voltage	S	Alarm
825	Operating temperature	1. Check ambient temperature 2. Check process temperature	S	Warning
844	Process value out of specification	1. Check process value 2. Check application 3. Check sensor	S	Warning

9.5 Firmware history

Revision history

The firmware version (FW) on the nameplate and in the Operating Instructions indicates the device release: XX.YY.ZZ (example 01.02.01).

XX Change to main version. No longer compatible. The device and Operating Instructions change.

YY Change to functions and operation. Compatible. The Operating Instructions change.

ZZ Fixes and internal changes. No changes to the Operating Instructions.

Date	Firmware version	Changes	Documentation
12/2021	01.01.zz	Original firmware	BA02157T/09/EN/01.21

10 Maintenance

No special maintenance work is required for the device.

Cleaning

A clean, dry cloth can be used to clean the device.

11 Repair

11.1 General notes

Due to the device's design and construction, it cannot be repaired.

11.2 Spare parts

Device spare parts that are currently available can be found online at: http://www.products.endress.com/spareparts_consumables. Always quote the serial number of the device when ordering spare parts!

Type	Order number
Standard - DIN mounting set (2 screws and springs, 4 lock washers, 1 CDI connector cover)	71044061
US - M4 mounting set (2 screws and 1 CDI connector cover)	71044062

11.3 Return

The requirements for safe device return can vary depending on the device type and national legislation.

1. Refer to the website for more information: <http://www.endress.com/support/return-material>
2. Return the device if repairs or a factory calibration are required, or if the wrong device was ordered or delivered.

11.4 Disposal



If required by the Directive 2012/19/EU on waste electrical and electronic equipment (WEEE), our products are marked with the depicted symbol in order to minimize the disposal of WEEE as unsorted municipal waste. Such products may not be disposed of as unsorted municipal waste and can be returned to Endress+Hauser for disposal at conditions stipulated in our General Terms and Conditions or as individually agreed.

12 Accessories

Various accessories, which can be ordered with the device or subsequently from Endress+Hauser, are available for the device. Detailed information on the order code in question is available from your local Endress+Hauser sales center or on the product page of the Endress+Hauser website: www.endress.com.



12.1 Device-specific accessories

Adapter for DIN rail mounting, DIN rail clip as per IEC 60715 (TH35) without securing screws
Standard - DIN mounting set (2 screws + springs, 4 lock washers and 1 CDI connector cover)
US - M4 securing screws (2 M4 screws and 1 CDI connector cover)



12.2 Communication-specific accessories

Accessories	Description
Commubox FXA291	Connects Endress+Hauser field devices with a CDI interface (= Endress+Hauser Common Data Interface) and the USB port of a computer or laptop.  For details, see Technical Information TI405C/07
Configuration kit TXU10	Configuration kit for PC-programmable transmitters – FDT/DTM-based plant asset management tool, FieldCare/DeviceCare and interface cable (4-pin plug-in connector) for PC with USB port.

12.3 Service-specific accessories

Accessories	Description
Applicator	Software for selecting and sizing Endress+Hauser measuring devices: <ul style="list-style-type: none"> Calculation of all the necessary data for identifying the optimum measuring device: e.g. pressure loss, accuracy or process connections. Graphic illustration of the calculation results Administration, documentation and access to all project-related data and parameters over the entire life cycle of a project. Applicator is available: Via the Internet: https://portal.endress.com/webapp/applicator
Configurator	Product Configurator - the tool for individual product configuration <ul style="list-style-type: none"> Up-to-the-minute configuration data Depending on the device: Direct input of measuring point-specific information such as measuring range or operating language Automatic verification of exclusion criteria Automatic creation of the order code and its breakdown in PDF or Excel output format Ability to order directly in the Endress+Hauser Online Shop The Configurator is available on the Endress+Hauser website at: www.endress.com -> Click "Corporate" -> Select your country -> Click "Products" -> Select the product using the filters and search field -> Open product page -> The "Configure" button to the right of the product image opens the Product Configurator.
DeviceCare SFE100	Configuration tool for devices via fieldbus protocols and Endress+Hauser service protocols. DeviceCare is the tool developed by Endress+Hauser for the configuration of Endress+Hauser devices. All smart devices in a plant can be configured via a point-to-point or point-to-bus connection. The user-friendly menus enable transparent and intuitive access to the field devices.  For details, see Operating Instructions BA00027S
FieldCare SFE500	FDT-based plant asset management tool from Endress+Hauser. It can configure all smart field units in your system and helps you manage them. By using the status information, it is also a simple but effective way of checking their status and condition.  For details, see Operating Instructions BA00027S and BA00065S

12.4 System components

Accessories	Description
RN22/RN42	RN22: 1- or 2-channel active barrier for the separation of 0/4 to 20 mA standard signal circuits, optionally available as a signal doubler, 24 V DC. HART-transparent RN42: 1-channel active barrier with wide range power supply for the safe separation of 0/4 to 20 mA standard signal circuits, HART-transparent  For details <ul style="list-style-type: none"> ■ Technical Information RN22 -> TI01515K ■ Technical Information RN42 -> TI01584K
RIA15	Process display, digital, loop-powered digital display unit for 4 to 20 mA circuits  For details, see Technical Information TI01043K
RNB22	System power supply with wide range input 100 to 240 V _{AC} / 110 to 250 V _{DC} Primary switched mode power supply, 1-phase, output 24 V _{DC} / 2.5 A  For details, see Technical Information TI01585K

13 Technical data

13.1 Input

Measured variable Temperature (temperature-linear transmission behavior)

Resistance thermometer (RTD) as per standard	Designation	α	Measuring range limits	Min. span
IEC 60751:2008	Pt100 (1) Pt1000 (4)	0.003851	-200 to +850 °C (-328 to +1562 °F) -200 to +250 °C (-328 to +482 °F)	10 K (18 °F)
JIS C1604:1984	Pt100 (5)	0.003916	-200 to +510 °C (-328 to +950 °F)	10 K (18 °F)
GOST 6651-94	Pt100 (9)	0.003910	-200 to +850 °C (-328 to +1562 °F)	10 K (18 °F)
-	Pt100 (Callendar van Dusen)	-	The measuring range limits are specified by entering the limit values that depend on the coefficients A to C and R0.	10 K (18 °F)
<ul style="list-style-type: none"> ▪ Type of connection: 2-wire, 3-wire or 4-wire connection, sensor current: ≤ 0.3 mA ▪ With 2-wire circuit, compensation of wire resistance possible (0 to 30 Ω) ▪ With 3-wire and 4-wire connection, sensor wire resistance up to max. 50 Ω per wire 				

13.2 Output

Output signal	Analog output	4 to 20 mA, 20 to 4 mA (can be inverted)
---------------	---------------	--

Failure information **Failure information as per NAMUR NE43:**
 Failure information is created if the measuring information is missing or not valid. The error with the highest priority is displayed.

Underranging	Linear drop from 4.0 to 3.8 mA
Overranging	Linear increase from 20.0 to 20.5 mA
Failure e.g. sensor failure; sensor short-circuit	≤ 3.6 mA ("Low") or ≥ 21 mA ("High"), can be selected

Linearization/transmission behavior Temperature-linear

Filter 1st order digital filter: 0 to 120 s
 Network frequency filter: 50/60 Hz (cannot be adjusted)

Protocol-specific data	DTM device description files	Information and files under: www.endress.com
------------------------	------------------------------	--

Switch-on delay ≤ 5 s, until the first valid measured value signal is present at the current output. While switch-on delay = $I_a \leq 3.8$ mA

13.3 Power supply

Supply voltage Values for non-hazardous areas, protected against polarity reversal:
 $10\text{ V} \leq V_{cc} \leq 36\text{ V}$ (standard)
 Values for hazardous areas, see Ex documentation.

Current consumption 3.5 to 22.5 mA

Electrical connection

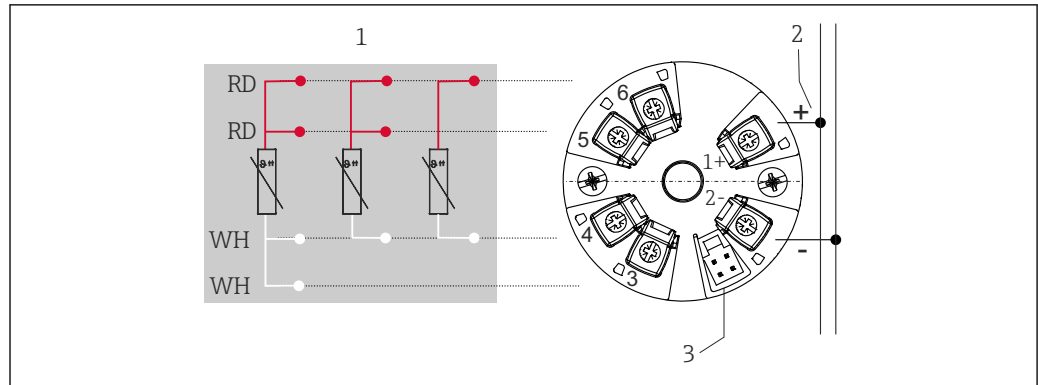

8 Terminal assignment of head transmitter

- 1 RTD sensor input: 4-, 3- and 2-wire
- 2 Power supply
- 3 CDI interface

Terminal

Choice of screw or push-in terminals for sensor and power supply cables:

Terminal design	Cable design	Cable cross-section
Screw terminals	Rigid or flexible	$\leq 1.5\text{ mm}^2$ (16 AWG)
Spring terminals ¹⁾ (Cable design, stripping length = min. 10 mm (0.39 in))	Rigid or flexible	0.2 to 1.5 mm ² (24 to 16 AWG)
	Flexible with wire end ferrules with/without plastic ferrule	0.25 to 1.5 mm ² (24 to 16 AWG)

1) Wire end ferrules must be used with spring terminals and when using flexible cables with a cable cross-section of $\leq 0.3\text{ mm}^2$.

13.4 Performance characteristics

Response time $\leq 0.5\text{ s}$

Reference operating conditions

- Calibration temperature: $+25\text{ °C} \pm 3\text{ K}$ ($77\text{ °F} \pm 5.4\text{ °F}$)
- Supply voltage: 24 V DC
- 4-wire circuit for resistance adjustment

Maximum measured error In accordance with DIN EN 60770 and the reference conditions specified above. The measured error data correspond to $\pm 2\sigma$ (Gaussian distribution). The data include non-linearities and repeatability.

MV = measured value

LRV = lower range value of sensor

Transmitter measured error

Version	Measured error (±)
In entire measuring range	0.15 K or 0.07 % of span ¹⁾
Increased accuracy in limited measuring range, -50 to +250 °C (-58 to +482 °F)	0.1 K or 0.07 % of span ¹⁾

1) whichever is higher

The measured error data correspond to 2 σ (Gaussian distribution)

Operating influences The measured error data correspond to 2 σ (Gaussian distribution).

Operating influences: ambient temperature and supply voltage for resistance temperature detector (RTD)

Designation	Standard	Ambient temperature: Influence (±) per 1 °C (1.8 °F) change		Supply voltage: Influence (±) per V change	
		0 to +200 °C (+32 to +392 °F)	Entire measuring range	0 to +200 °C (+32 to +392 °F)	Entire measuring range
Pt100 (1)	IEC 60751:2008	0.02 °C (0.04 °F)	0.04 °C (0.07 °F)	0.01 °C (0.014 °F)	0.02 °C (0.04 °F)
Pt1000 (4)		0.01 °C (0.02 °F)	0.02 °C (0.03 °F)	0.01 °C (0.009 °F)	0.01 °C (0.02 °F)
Pt100 (5)	JIS C1604:1984	0.01 °C (0.03 °F)	0.03 °C (0.05 °F)	0.01 °C (0.011 °F)	0.02 °C (0.03 °F)
Pt100 (9)	GOST 6651-94	0.02 °C (0.04 °F)	0.04 °C (0.07 °F)	0.01 °C (0.014 °F)	0.02 °C (0.04 °F)

Long-term drift (±) ¹⁾		
after 1 year	after 3 years	after 5 years
Based on measured value		
0.05 K or 0.03 % of span	0.06 K or 0.04 % of span	0.07 K or 0.05 % of span

1) whichever is higher

Calculation of the maximum measured error of the analog value (current output):
 $\sqrt{(\text{Measured error}^2 + \text{Influence of ambient temperature}^2 + \text{Influence of supply voltage}^2)}$

Sensor adjustment

Sensor-transmitter-matching

To significantly improve the temperature measurement accuracy of RTD sensors, the device enables the following method:

Callendar-Van-Dusen coefficients (Pt100 RTD assembly)

The Callendar-Van-Dusen equation is described as:

$$R_T = R_0 [1 + AT + BT^2 + C(T - 100)T^3]$$

The coefficients A, B and C are used to match the sensor (platinum) and transmitter in order to improve the accuracy of the measuring system. The coefficients for a standard sensor are specified in IEC 751. If no standard sensor is available or if greater accuracy is required, the coefficients for each sensor can be determined specifically with the aid of sensor calibration.

Sensor-transmitter-matching using the method explained above significantly improves the temperature measurement accuracy of the entire system. This is because the transmitter

uses the specific data pertaining to the connected sensor to calculate the measured temperature, instead of using the standardized sensor curve data.

1-point adjustment (offset)

Shifts the sensor value

Current output adjustment Correction of the 4 and/or 20 mA current output value.

13.5 Environment

Ambient temperature -40 to +85 °C (-40 to +185 °F),

Storage temperature -50 to +100 °C (-58 to +212 °F)

Operating altitude Up to 4000 m (4374.5 yards) above sea level.

Humidity

- Condensation:
Permitted
- Max. rel. humidity: 95 % as per IEC 60068-2-30

Climate class Climate class C1 according to IEC 60654-1

Degree of protection With screw terminals: IP 00, with spring terminals: IP 30. In the installed state, it depends on the terminal head or housing used for field mounting.

Shock and vibration resistance

Vibration resistance as per DNVGL-CG-0339 : 2015 and DIN EN 60068-2-27
8.6 to 150 Hz at 3g

Shock resistance as per KTA 3505 (section 5.8.4 Shock test)

Electromagnetic compatibility (EMC)

CE conformity

Electromagnetic compatibility in accordance with all the relevant requirements of the IEC/EN 61326 series and NAMUR Recommendation EMC (NE21). For details, refer to the Declaration of Conformity.

Maximum measured error <1% of measuring range.

Interference immunity as per IEC/EN 61326 series, industrial requirements

Interference emission as per IEC/EN 61326 series (CISPR 11), Class B, group 1 equipment

Measuring category Measuring category II as per IEC 61010-1. The measuring category is provided for measuring on power circuits that are directly connected electrically with the low-voltage network.

Pollution degree Pollution degree 2 as per IEC 61010-1

13.6 Mechanical construction

Design, dimensions

Dimensions in mm (in)

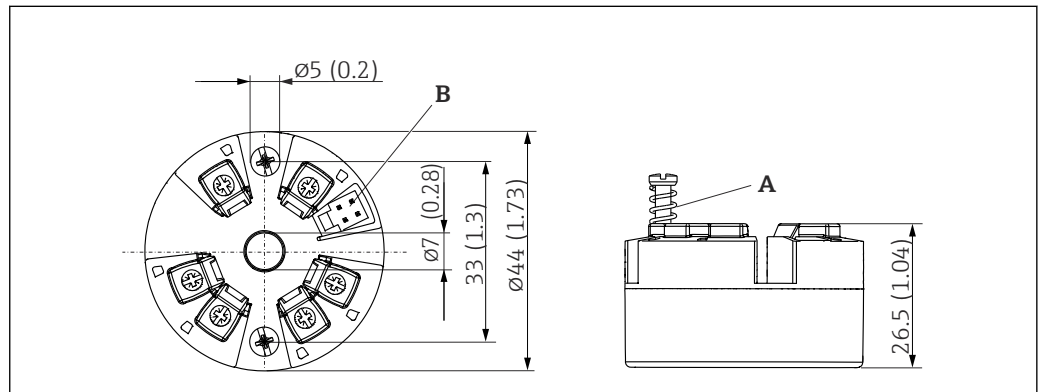

9 Version with screw terminals

A Spring travel $L \geq 5$ mm (not for US - M4 securing screws)

B CDI interface for connecting a configuration tool

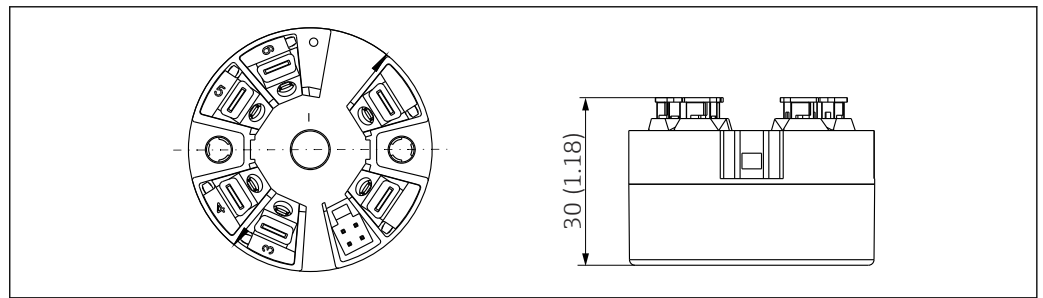

10 Version with spring terminals. Dimensions are identical to the version with screw terminals, apart from housing height.

Weight

40 to 50 g (1.4 to 1.8 oz)

Materials

All the materials used are RoHS-compliant.

- Housing: polycarbonate (PC)
- Terminals:
 - Screw terminals: nickel-plated brass
 - Push-in terminals: tin-plated brass, contact springs 1.4310, 301 (AISI)
- Potting compound: SIL gel

13.7 Certificates and approvals

Current certificates and approvals for the product are available via the Product Configurator at www.endress.com.

1. Select the product using the filters and search field.
2. Open the product page.

The **Configuration** button opens the Product Configurator.

MTTF

418 years

The mean time to failure (MTTF) denotes the theoretically expected time until the device fails during normal operation. The term MTTF is used for systems that cannot be repaired, e.g. temperature transmitters.

13.8 Documentation

- Technical Information 'iTEMP TMT31' with analog output 4 to 20 mA (TI01613T) and associated printed copy of Brief Operating Instructions 'iTEMP TMT31' (KA01540T)
- Description of Device Parameters (GP01182T)
- Supplementary ATEX (XA02682T) and CSA (XA02683T) documentation



71543167

www.addresses.endress.com
