

Operating Instructions

RLN42

Two-channel NAMUR isolating amplifier with universal power supply and relay signal output



Table of contents

1	About this document	3	11.2	Spare parts	16
1.1	Document function	3	11.3	Return	17
1.2	Symbols	3	11.4	Disposal	17
2	Basic safety instructions	5	12	Technical data	18
2.1	Requirements for the personnel	5	12.1	Function and system design	18
2.2	Intended use	5	12.2	Input	18
2.3	Workplace safety	5	12.3	Output	18
2.4	Operational safety	5	12.4	Power supply	19
2.5	Product safety	6	12.5	Performance characteristics	20
2.6	Installation instructions	6	12.6	Installation	20
3	Product descriptions	7	12.7	Environment	21
3.1	Product description RLN42	7	12.8	Mechanical construction	22
4	Incoming acceptance and product identification	7	12.9	Display and operating elements	23
4.1	Incoming acceptance	7	12.10	Ordering information	24
4.2	Product identification	7	12.11	Accessories	25
4.3	Scope of delivery	8	12.12	Certificates and approvals	25
4.4	Certificates and approvals	8	12.13	Documentation	26
4.5	Storage and transport	9	13	Appendix: system overview of RN Series	27
5	Mounting	9	13.1	Power supply of RN Series	27
5.1	Mounting requirements	9	13.2	Applications of the isolating amplifiers	27
5.2	Installing a DIN rail device	9	Index	31	
5.3	Disassembling the DIN rail device	10			
6	Electrical connection	11			
6.1	Connecting requirements	11			
6.2	Quick wiring guide	12			
6.3	Supply voltage	12			
6.4	Post-connection check	12			
7	Operating options	13			
7.1	Display and operating elements	13			
8	Commissioning	14			
8.1	Post-installation check	14			
8.2	Switching on the device	15			
9	Diagnostics and troubleshooting ...	16			
9.1	General troubleshooting	16			
10	Maintenance	16			
11	Repair	16			
11.1	General information	16			





1 About this document

1.1 Document function













These Operating Instructions contain all the information that is required in various phases of the life cycle of the device: from product identification, incoming acceptance and storage, to mounting, connection, operation and commissioning through to troubleshooting, maintenance and disposal.

1.2 Symbols





1.2.1 Safety symbols

 DANGER This symbol alerts you to a dangerous situation. Failure to avoid this situation will result in serious or fatal injury.	 WARNING This symbol alerts you to a dangerous situation. Failure to avoid this situation can result in serious or fatal injury.
 CAUTION This symbol alerts you to a dangerous situation. Failure to avoid this situation can result in minor or medium injury.	 NOTICE This symbol contains information on procedures and other facts which do not result in personal injury.

1.2.2 Symbols for certain types of information

Symbol	Meaning
	Permitted Procedures, processes or actions that are permitted.
	Preferred Procedures, processes or actions that are preferred.
	Forbidden Procedures, processes or actions that are forbidden.
	Tip Indicates additional information.
	Reference to documentation
	Reference to page
	Reference to graphic
	Notice or individual step to be observed
	Series of steps
	Result of a step
	Help in the event of a problem
	Visual inspection

1.2.3 Electrical symbols

	Direct current		Alternating current
	Direct current and alternating current		Ground connection A grounded terminal which, as far as the operator is concerned, is grounded via a grounding system.

1.2.4 Symbols in graphics

1, 2, 3,...	Item numbers	A, B, C, ...	Views
-------------	--------------	--------------	-------

1.2.5 Symbols at the device

	Warning Observe the safety instructions contained in the associated Operating Instructions
---	--

2 Basic safety instructions

2.1 Requirements for the personnel

The personnel for installation, commissioning, diagnostics and maintenance must fulfill the following requirements:

- ▶ Trained, qualified specialists must have a relevant qualification for this specific function and task.
- ▶ Are authorized by the plant owner/operator.
- ▶ Are familiar with federal/national regulations.
- ▶ Before starting work, read and understand the instructions in the manual and supplementary documentation as well as the certificates (depending on the application).
- ▶ Follow instructions and comply with basic conditions.

The operating personnel must fulfill the following requirements:

- ▶ Are instructed and authorized according to the requirements of the task by the facility's owner-operator.
- ▶ Follow the instructions in this manual.

2.2 Intended use

2.2.1 NAMUR isolating amplifier

The NAMUR isolating amplifier is designed for the operation of proximity switches, floating contacts and contacts with a resistive circuit. A relay is available per channel as the signal output. The device is designed for installation on DIN rails in accordance with IEC 60715.

2.2.2 Product liability

The manufacturer does not accept any responsibility for damage that results from non-designated use and from failure to comply with the instructions in this manual.

2.3 Workplace safety

For work on and with the device:

- ▶ Wear the required personal protective equipment according to federal/national regulations.

2.4 Operational safety

Risk of injury!

- ▶ Operate the device only if it is in proper technical condition, free from errors and faults.
- ▶ The operator is responsible for interference-free operation of the device.

Modifications to the device

Unauthorized modifications to the device are not permitted and can lead to unforeseeable dangers:

- ▶ If modifications are nevertheless required, consult with the manufacturer.

Repair

To ensure continued operational safety and reliability:

- ▶ Carry out repairs on the device only if they are expressly permitted.
- ▶ Observe federal/national regulations pertaining to the repair of an electrical device.

- ▶ Use only original spare parts and accessories from the manufacturer.

Hazardous area

To eliminate danger to persons or the facility when the device is used in the hazardous area (e.g. explosion protection):

- ▶ Check the nameplate to verify if the device ordered can be put to its intended use in the hazardous area.
- ▶ Observe the specifications in the separate supplementary documentation that is an integral part of these instructions.

2.5 Product safety

This device is designed in accordance with good engineering practice to meet state-of-the-art safety requirements, has been tested, and left the factory in a condition in which it is safe to operate.

2.6 Installation instructions

- The device's IP20 degree of protection is intended for a clean and dry environment.
- Do not expose the device to mechanical and/or thermal stress that exceeds the specified limits.
- The device is intended for installation in a cabinet or similar housing. The device may only be operated as an installed device.
The cabinet must meet the fire protection housing requirements according to safety standard UL/IEC 61010-1 and provide adequate protection against electric shock or burns.
- To protect against mechanical or electrical damage, the device must be installed in an appropriate housing with a suitable degree of protection according to IEC/EN 60529.
- The device fulfills the EMC regulations for the industrial sector (EMC Class A). It can cause electrical interference if used in residential environments.
- During installation, repair and maintenance work, the device must be disconnected from all effective power sources if the power sources are not SELV or PELV circuits.
- Only use copper cables with a permitted temperature range (60 °C / 75 °C) as the connection cable.

3 Product descriptions

3.1 Product description RLN42

3.1.1 Product design

NAMUR isolating amplifier

- The NAMUR isolating amplifier is designed for the operation of proximity switches (according to EN 60947-5-6 (NAMUR)) and open and mechanical contacts with resistive coupling elements. One relay (changeover) per channel is available as a signal output. The power supply is designed as a universal power supply (UP).
- The device is optionally available with Ex approvals for the intrinsically safe operation of proximity switches installed in the hazardous area. Separate Ex documentation (XA) is supplied with these devices. Compliance with the installation instructions and connection data in this documentation is mandatory!
- The device is optionally available for safety-oriented applications up to SIL 2 in accordance with IEC 61508.
- A resistive coupling element (1 k Ω / 10 k Ω) is available as an optional accessory and can be used to monitor line faults of sensors with mechanical contacts. The resistive coupling element is installed onsite directly at the contact to be monitored or in the sensor connection compartment.

4 Incoming acceptance and product identification

4.1 Incoming acceptance

Check the following during incoming acceptance:

- Are the order codes on the delivery note and the product sticker identical?
- Are the goods undamaged?
- Do the nameplate data match the ordering information on the delivery note?



If one of these conditions is not met, please contact the manufacturer's sales office.

4.2 Product identification

The following options are available for identification of the device:

- Nameplate specifications
- Extended order code with breakdown of the device features on the delivery note
- Enter the serial number from the nameplate in the *W@M Device Viewer* (www.endress.com/deviceviewer): all data relating to the device and an overview of the Technical Documentation supplied with the device are displayed.
- Enter the serial number on the nameplate into the *Endress+Hauser Operations App* or scan the 2-D matrix code (QR code) on the nameplate with the *Endress+Hauser Operations App*: all the information about the device and the technical documentation pertaining to the device is displayed.

4.2.1 Nameplate

The right device?

Compare and check the data on the nameplate of the device against the requirements of the measuring point:

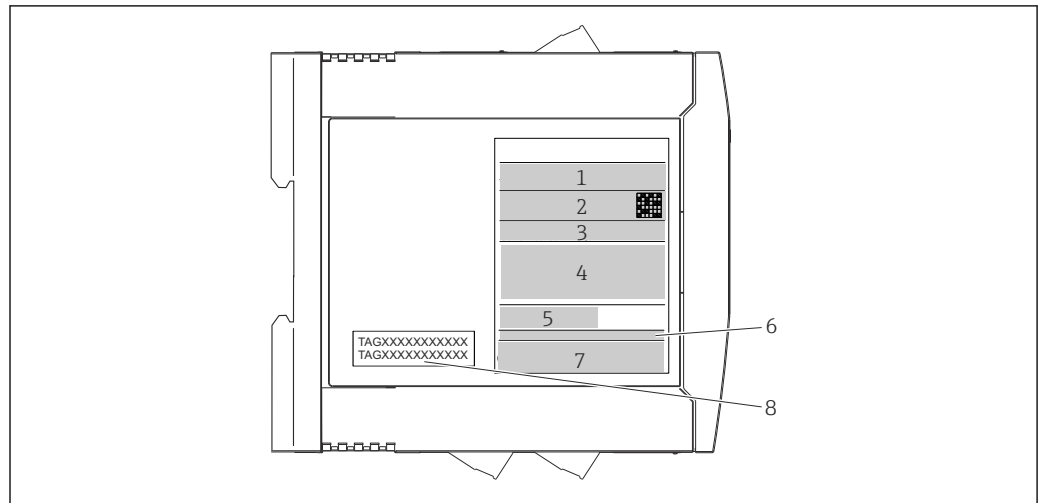

A0041996

1 Nameplate (example of Ex version)

- 1 Product name and manufacturer ID
- 2 Order code, extended order code and serial number, DataMatrix 2D code, FCC-ID (if applicable)
- 3 Power supply and current consumption, output
- 4 Approval in hazardous area with number of the relevant Ex documentation (XA...)
- 5 Fieldbus communication logo
- 6 Firmware version and device revision
- 7 Approval logos
- 8 2 lines for the TAG name

4.2.2 Name and address of manufacturer

Name of manufacturer:	Endress+Hauser Wetzer GmbH + Co. KG
Address of manufacturer:	Obere Wank 1, D-87484 Nesselwang
Model/type reference:	RLN42

4.3 Scope of delivery

The scope of delivery comprises:

- Device as per order
- Printed copy of the Brief Operating Instructions
- Optional: Functional safety manual (SIL mode)
- Additional documentation for devices which are suitable for use in the hazardous area (Ex, ATEX, IECEx), such as Safety Instructions (XA...), Control or Installation Drawings (ZD...).

4.4 Certificates and approvals

i For certificates and approvals valid for the device: see the data on the nameplate

i Approval-related data and documents: www.endress.com/deviceviewer → (enter the serial number)

4.4.1 Functional safety

A SIL version of the device is optionally available. It can be used in safety equipment in accordance with IEC 61508 up to SIL 2.



Please refer to Safety Manual FY01035K for the use of the device in safety instrumented systems according to IEC 61508.



Protection against modifications:

As it is not possible to disengage the operating elements (keys and DIP switches), a lockable control cabinet is required for use in SIL applications. The cabinet must be locked by key. A normal electrical cabinet key does not suffice for this purpose.

4.5 Storage and transport



When storing and transporting the device, pack it so that it is reliably protected against impact. The original packaging provides optimum protection.

5 Mounting

5.1 Mounting requirements

5.1.1 Dimensions

The device dimensions can be found in the "Technical data" section of the Operating Instructions.

5.1.2 Mounting location

The device is designed for installation on 35 mm (1.38 in) DIN rails in accordance with IEC 60715 (TH35).

The device's housing provides basic insulation from neighboring devices for 300 Veff. If several devices are installed side by side, this must be taken into consideration and additional insulation must be provided if necessary. If the adjacent device also offers basic insulation, no additional insulation is required.

NOTICE

- ▶ When using in hazardous areas, the limit values of the certificates and approvals must be observed.



For information on ambient conditions, see the "Technical data" section.

5.2 Installing a DIN rail device

The device can be installed in any position (horizontal or vertical) on the DIN rail without lateral clearance from neighboring devices. No tools are required for installation. The use of end brackets (type WEW "35/1" or similar) on the DIN rail is recommended as an end support for the device.

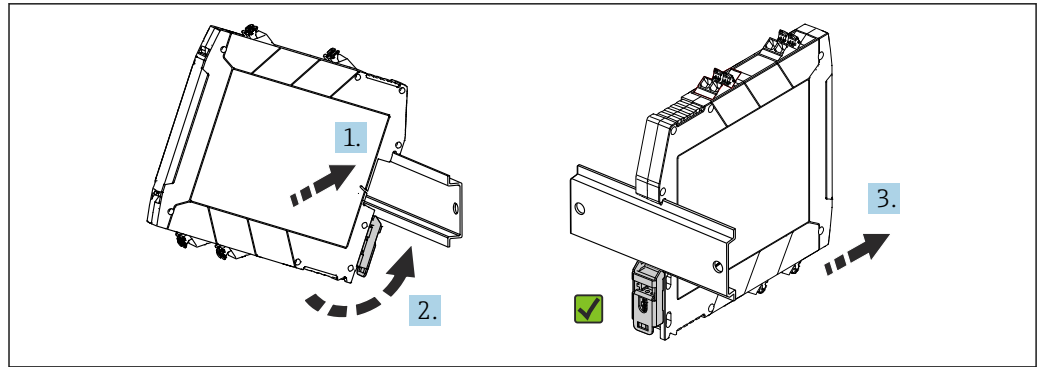

A0041736

 2 *Installing on DIN rail*

1. Position the top DIN rail groove at the top end of the DIN rail.
2. While holding the front of the device horizontally, lower it until you hear the locking clip of the device click into place on the DIN rail.
3. Pull gently on the device to check if it is correctly mounted on the DIN rail.

5.3 Disassembling the DIN rail device

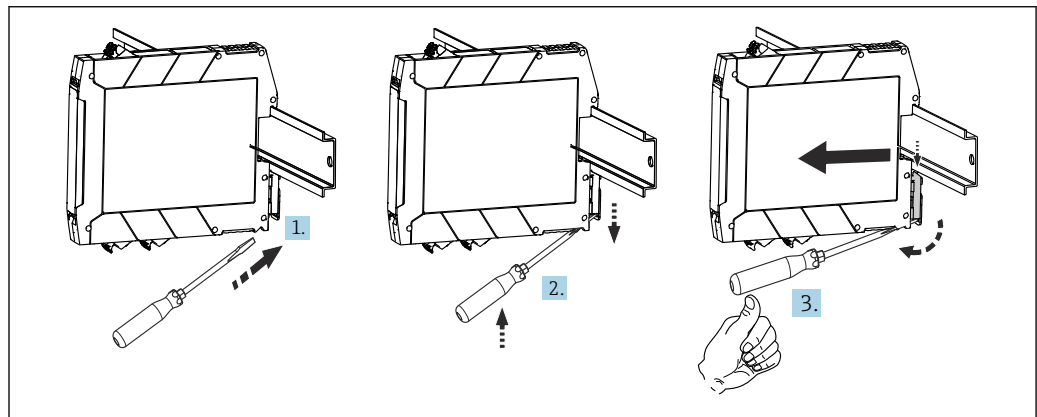

A0039696

 3 *Disassembling the DIN rail device*

1. Insert a screwdriver into the tab of the DIN rail clip.
2. Use the screwdriver to pull down on the DIN rail clip as shown in the diagram.
3. Hold down the screwdriver to remove the device from the DIN rail.

6 Electrical connection

6.1 Connecting requirements

A flat-blade screwdriver is required to establish an electrical connection to screw or push-in terminals.

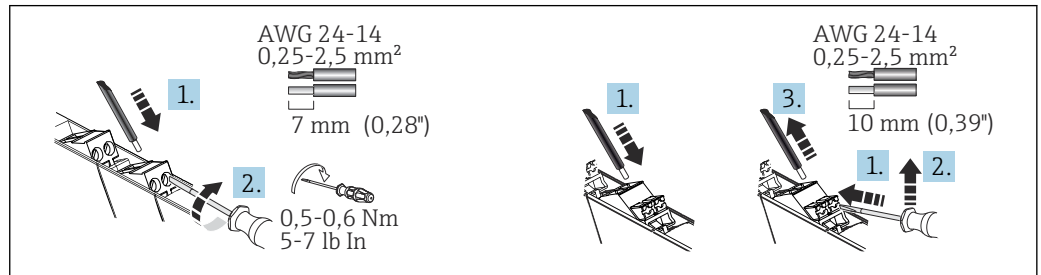

4 Electrical connection using screw terminals (left) and push-in terminals (right)

CAUTION

Destruction of parts of the electronics

- ▶ Switch off the power supply before installing or connecting the device.

NOTICE

Destruction or malfunction of parts of the electronics

- ▶  ESD - Electrostatic discharge. Protect the terminals from electrostatic discharge.

6.1.1 Special connection instructions

- Disconnecting units and auxiliary circuit protective systems with suitable AC or DC values must be provided in the building installation.
- A switch/power circuit breaker must be provided close to the device and clearly marked as a disconnecting unit for this device.
- An overcurrent protection unit ($I \leq 16$ A) must be provided in the installation.
- The voltages applied at the input are extra-low voltages (ELV). Depending on the application, the supply and switching voltage at the relay output can be a dangerous voltage (>30 V). Safe galvanic isolation to the other connections is provided for this scenario.



For information on the connection data, see the "Technical data" section.

6.2 Quick wiring guide

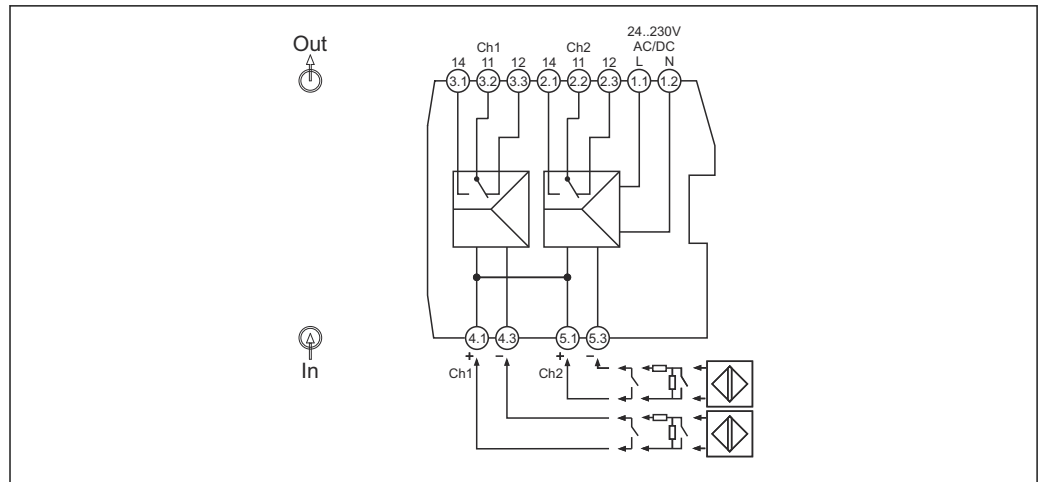

A0043438

5 Terminal assignment RLN42

6.3 Supply voltage

The modules are supplied with 24 to 230 V_{AC/DC} via terminals 1.1 and 1.2.

6.4 Post-connection check

Device health and specifications	Notes
Are the device and cables undamaged (visual check)?	--
Do the ambient conditions match the device specification (e.g. ambient temperature, measuring range, etc.)?	See "Technical data"
Electrical connection	Notes
Does the supply voltage match the information on the nameplate?	U = e.g. 24 to 230 V _{AC/DC}
Are the power supply and signal cables connected correctly?	--
Are all the screw terminals well tightened and have the connections of the push-in terminals been checked?	--

7 Operating options

7.1 Display and operating elements

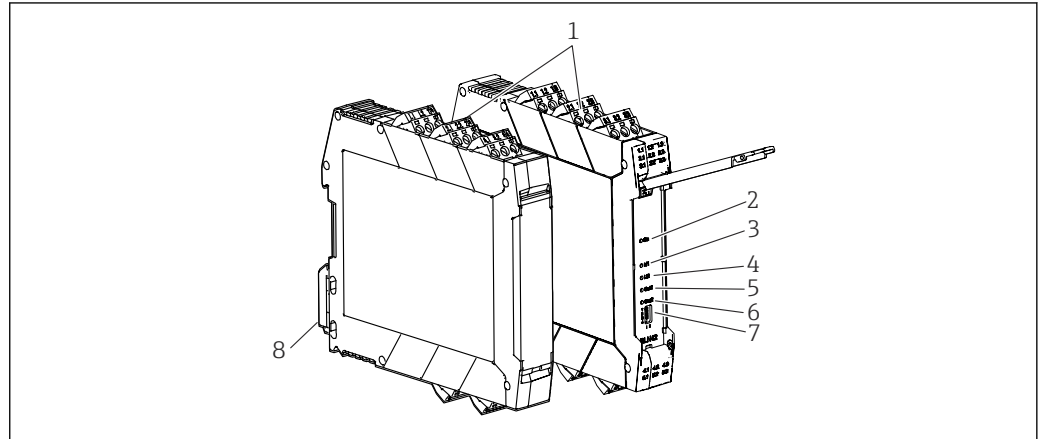

 6 Display and operating elements

- 1 Plug-in screw or push-in terminal
- 2 Green LED "On", power supply
- 3 Red LED "LF1", line fault of sensor cable 1
- 4 Red LED "LF2", line fault of sensor cable 2
- 5 Yellow LED "OUT1", status relay 1
- 6 Yellow LED "OUT2", status relay 2
- 7 DIP switches 1 to 4
- 8 DIN rail clip for DIN rail mounting

A0043446

7.1.1 Local operation

Hardware settings / configuration

 Any device settings using the DIP switch must be made when the device is de-energized.

Direction of action

At the device, the direction of action (operating or closed circuit current behavior) can be selected and line fault detection can be enabled or disabled via DIP switches.

DIP switch 1 = channel 1; DIP switch 3 = channel 2

All DIP switches are set to the "I" position when the device is delivered from the factory:

- I = normal phase (operating current behavior)
- II = inverse phase (closed circuit current behavior)

DIP switch 1:

- DIP switch position I = normal function: in the event of a 0-signal at the input, the relay output (changeover) switches to the "non-conducting" state (NO contact is open) or "conducting" state (NC contact is closed).
- DIP switch position II = inverse function: in the event of a 1-signal at the input, the relay output (changeover) switches to the "non-conducting" state (NO contact is open) or "conducting" state (NC contact is closed).

Line fault detection

DIP switch 2 = channel 1; DIP switch 4 = channel 2

I = line fault detection switched off - **not permitted for safety-oriented applications!**

II = line fault detection switched on

If a line fault occurs, the relay is de-energized and the red LED "LF" flashes (NE 44).

NOTICE

Error detection malfunctions

- For switch contacts with an open circuit, line fault detection (LF) must be disabled or the corresponding resistance circuit (1 kΩ/10 kΩ) must be provided directly at the contact. (See the "Quick wiring guide" and "Accessories" sections of the Operating Instructions)

7.1.2 Truth table, 2-channel

Sensor at input			Input circuit	DIP switch Channel 1		DIP switch Channel 2		Output Relay contact		LED		Permitted for safety-oriented applications
Switch	Contacts with resistive coupling elements	NAMUR		Status	1	2	3	4	NO contact	NC contact	OUT yellow	
Open	Open	Blocking	OK	I	I	I	I	Open	Closed			No
Closed	Closed	Conducting	OK	I	I	I	I	Closed	Open	X		No
Open	Open	Blocking	OK	II	I	II	I	Closed	Open	X		No
Closed	Closed	Conducting	OK	II	I	II	I	Open	Closed			No
	Open	Blocking	OK	I	II	I	II	Open	Closed			Yes
	Closed	Conducting	OK	I	II	I	II	Closed	Open	X		Yes
	Any state	Any state	Wire break	I	II	I	II	Open	Closed		X	Yes
	Any state	Any state	Short circuit	I	II	I	II	Open	Closed		X	Yes
	Open	Blocking	OK	II	II	II	II	Closed	Open	X		Yes
	Closed	Conducting	OK	II	II	II	II	Open	Closed			Yes
	Any state	Any state	Wire break	II	II	II	II	Open	Closed		X	Yes
	Any state	Any state	Short circuit	II	II	II	II	Open	Closed		X	Yes

8 Commissioning

8.1 Post-installation check

Before commissioning the device, ensure that all post-mounting and post-connection checks have been carried out.

NOTICE

- ▶ Before commissioning the device, make sure that the supply voltage matches the voltage specifications on the nameplate. Failure to perform these checks may result in damage to the device caused by the incorrect supply voltage.

8.2 Switching on the device

Switch on the supply voltage. The green LED display on the front of the device indicates that the device is operational.

9 Diagnostics and troubleshooting

9.1 General troubleshooting

Always start troubleshooting with the checklists below if faults occur after startup or during operation. The checklists take you directly (via various queries) to the cause of the problem and the appropriate remedial measures.

 Due to its design, the device cannot be repaired. However, it is possible to send the device in for examination. See the "Return" section.

General faults

Fault	Possible cause	Remedial action
Device does not respond.	Supply voltage does not match the voltage specified on the nameplate.	Check the voltage directly using a voltmeter and correct.
	Connecting cables are not in contact with the terminals.	Ensure electrical contact between the cable and the terminal.
	Electronics module is defective.	Replace the device.
The status LED on the DIN rail device is lit or flashing (red).	Diagnostics events as per NAMUR NE107.	Check diagnostics events: <ul style="list-style-type: none"> ▪ LED is lit: diagnostics display, category F ▪ LED is flashing: diagnostics display of categories C, S or M
The power LED on the DIN rail device is not lit (green).	Power failure or insufficient supply voltage.	Check the supply voltage and check if wiring is correct.

10 Maintenance

No special maintenance work is required for the device.

Cleaning

A clean, dry cloth can be used to clean the device.

11 Repair

11.1 General information

Due to its design, the device cannot be repaired.

11.2 Spare parts

Spare parts currently available for the device can be found online at: http://www.products.endress.com/spareparts_consumables. Always quote the serial number of the device when ordering spare parts!

Type	Order code
Plug-in terminal set, 3-pin, DIN rail interfaces - screw	71505345
Plug-in terminal set, 3-pin, DIN rail interfaces - push-in	71505346
Front cover 17.5 mm, DIN rail housing (5 pcs per pack)	71505348

11.3 Return

The requirements for safe device return can vary depending on the device type and national legislation.

1. Refer to the website for more information:
<http://www.endress.com/support/return-material>
2. Return the device if repairs or a factory calibration are required, or if the wrong device was ordered or delivered.

11.4 Disposal



If required by the Directive 2012/19/EU on waste electrical and electronic equipment (WEEE), the product is marked with the depicted symbol in order to minimize the disposal of WEEE as unsorted municipal waste. Do not dispose of products bearing this marking as unsorted municipal waste. Instead, return them to the manufacturer for disposal under the applicable conditions.

12 Technical data

12.1 Function and system design

Product description RLN42

Product design

NAMUR isolating amplifier

- The NAMUR isolating amplifier is designed for the operation of proximity switches (according to EN 60947-5-6 (NAMUR)) and open and mechanical contacts with resistive coupling elements. One relay (changeover) per channel is available as a signal output. The power supply is designed as a universal power supply (UP).
- The device is optionally available with Ex approvals for the intrinsically safe operation of proximity switches installed in the hazardous area. Separate Ex documentation (XA) is supplied with these devices. Compliance with the installation instructions and connection data in this documentation is mandatory!
- The device is optionally available for safety-oriented applications up to SIL 2 in accordance with IEC 61508.
- A resistive coupling element (1 kΩ / 10 kΩ) is available as an optional accessory and can be used to monitor line faults of sensors with mechanical contacts. The resistive coupling element is installed onsite directly at the contact to be monitored or in the sensor connection compartment.

Dependability

We only provide a warranty if the device is installed and used as described in the Operating Instructions.

12.2 Input

Version

The following version is available:
2-channel

Input data

(floating switch contacts with resistive coupling elements to connect NAMUR proximity switches (IEC/EN 60947-5-6))

Switch points	Blocking: < 1.2 mA Conducting: > 2.1 mA	Line fault detection	Line break: 0.05 mA < I _{IN} < 0.35 mA Short-circuit: 100 Ω < R _{sensor} < 360 Ω
Short-circuit current	~ 8 mA	Open-circuit voltage	~ 8 V _{DC}
Switching hysteresis	< 0.2 mA		

12.3 Output

Relay output data

Relay output data

Contact version	1 changeover per channel	Mechanical operating life	10 ⁷ switching cycles
Maximum switching voltage/current	250 V _{DC} (2 A) / 120 V _{DC} (0.2 A) / 30 V _{DC} (2 A)	Recommended minimum load	5 V / 10 mA

Maximum switching capacity	500 VA	Switching frequency (no load)	≤ 20 Hz
Contact material	AgSnO ₂ , hard gold plated	Direction of action	Operating current or closed circuit current

Signal on alarm	Output behavior in an alarm condition	If line fault detection is switched on and the line to the sensor is disconnected or short-circuits, the relay de-energizes in such a way that the output is set to the safe, non-conducting state.
	Line break in input	0.05 mA < I _{IN} < 0.35 mA
	Line short circuit in input	100 Ω < R _{sensor} < 380 Ω

Ex connection data See associated XA Safety Instructions

Galvanic isolation	Input / output	Peak value as per EN 60079-11 375 V
	Input / power supply	Peak value as per EN 60079-11 375 V

12.4 Power supply

Terminal assignment Quick wiring guide

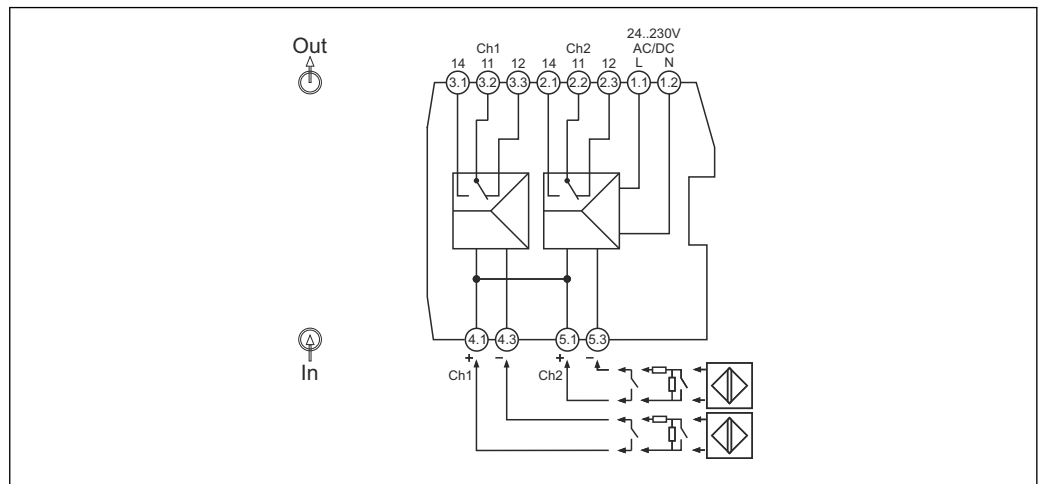

7 Terminal assignment RLN42

Supply voltage The modules are supplied with 24 to 230 V_{AC/DC} via terminals 1.1 and 1.2.

Important connection data **Power supply**

Supply voltage range	24 to 230 V _{AC/DC} (-20% / +10%, 0/50/60 Hz)	Maximum current consumption	≤ 80 mA (230 V _{AC}) ≤ 42 mA (24 V _{DC})
Power dissipation	≤ 1.3 W	Power consumption	≤ 1.1 W

Terminals A flat-blade screwdriver is required to establish an electrical connection to screw or push-in terminals.

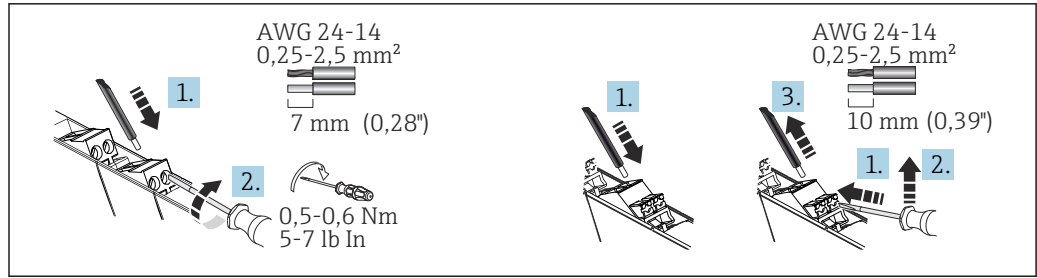

A0040201

8 Electrical connection using screw terminals (left) and push-in terminals (right)

Terminal design	Cable design	Cable cross-section
Screw terminals Tightening torque: minimum 0.5 Nm/maximum 0.6 Nm	Rigid or flexible (Stripping length = 7 mm (0.28 in))	0.2 to 2.5 mm ² (24 to 14 AWG)
	Flexible with wire end ferrules (with or without plastic ferrule)	0.25 to 2.5 mm ² (24 to 14 AWG)
Push-in spring terminals	Rigid or flexible (Stripping length = 10 mm (0.39 in))	0.2 to 2.5 mm ² (24 to 14 AWG)
	Flexible with wire end ferrules (with or without plastic ferrule)	0.25 to 2.5 mm ² (24 to 14 AWG)

12.5 Performance characteristics

Response time Following a change of state at the input, the output adopts the safe state in ≤ 40 ms.

12.6 Installation

Mounting location The device is designed for installation on 35 mm (1.38 in) DIN rails in accordance with IEC 60715 (TH35).

The device's housing provides basic insulation from neighboring devices for 300 Veff. If several devices are installed side by side, this must be taken into consideration and additional insulation must be provided if necessary. If the adjacent device also offers basic insulation, no additional insulation is required.

NOTICE

- ▶ When using in hazardous areas, the limit values of the certificates and approvals must be observed.

i For information on ambient conditions, see the "Technical data" section.

Installing a DIN rail device The device can be installed in any position (horizontal or vertical) on the DIN rail without lateral clearance from neighboring devices. No tools are required for installation. The use of end brackets (type "WEW 35/1" or similar) on the DIN rail is recommended to fix the device.

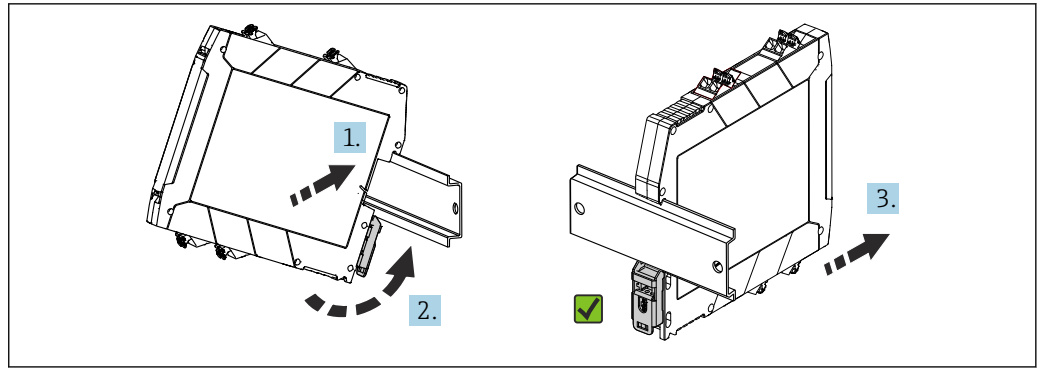

9 Installing on DIN rail

1. Position the top DIN rail groove at the top end of the DIN rail.
2. While holding the front of the device horizontally, lower it until you hear the locking clip of the device click into place on the DIN rail.
3. Pull gently on the device to check if it is correctly mounted on the DIN rail.

12.7 Environment

Important ambient conditions	Ambient temperature range	-40 to 60 °C (-40 to 140 °F)	Storage temperature	-40 to 80 °C (-40 to 176 °F)
	Degree of protection	IP 20	Overvoltage category	III
	Pollution degree	2	Humidity	10 to 95 % No condensation
	Altitude	≤ 2 000 m (6 562 ft)		

Shock and vibration resistance

Vibration resistance as per DNVGL-CG-0339 : 2015 and DIN EN 60068-2-27
 DIN rail device: 2 to 100 Hz at 0.7g (general vibration stress)
 Shock resistance as per KTA 3505 (section 5.8.4 Shock test)

Electromagnetic compatibility (EMC)

Interference immunity as per EN 61000-6-2
 Interference emission as per EN 61000-6-4

12.8 Mechanical construction

Design, dimensions

Dimensions in mm (in)

Terminal housing for mounting on DIN rail

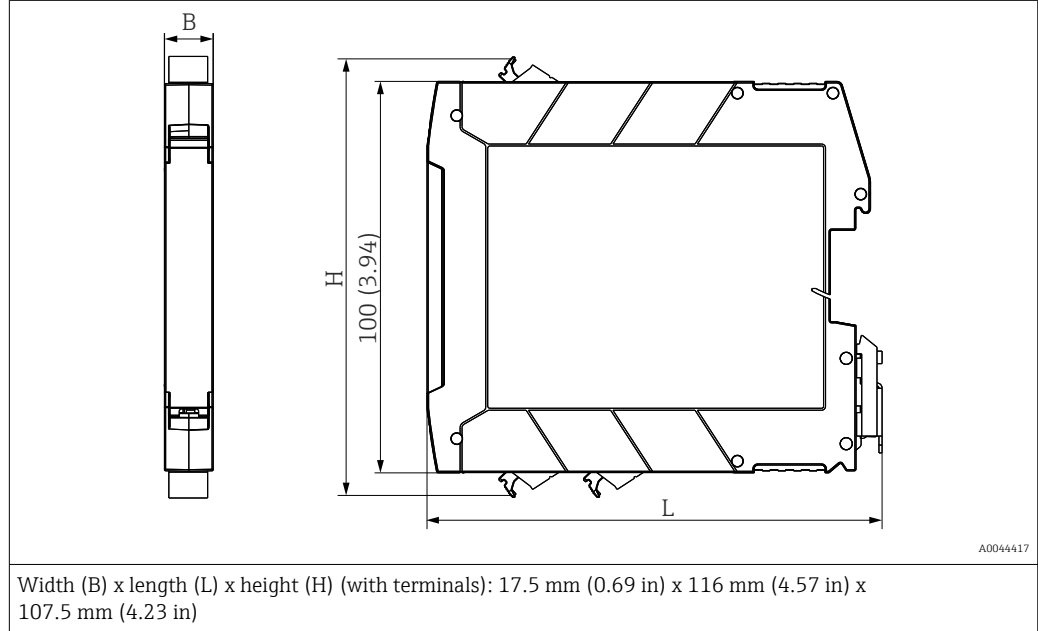

Weight

Device with terminals (values rounded up):
Approx. 140 g (4.94 oz)

Color

Light gray

Materials

All the materials used are RoHS-compliant.
Housing: polycarbonate (PC); flammability rating according to UL94: V-0

12.9 Display and operating elements

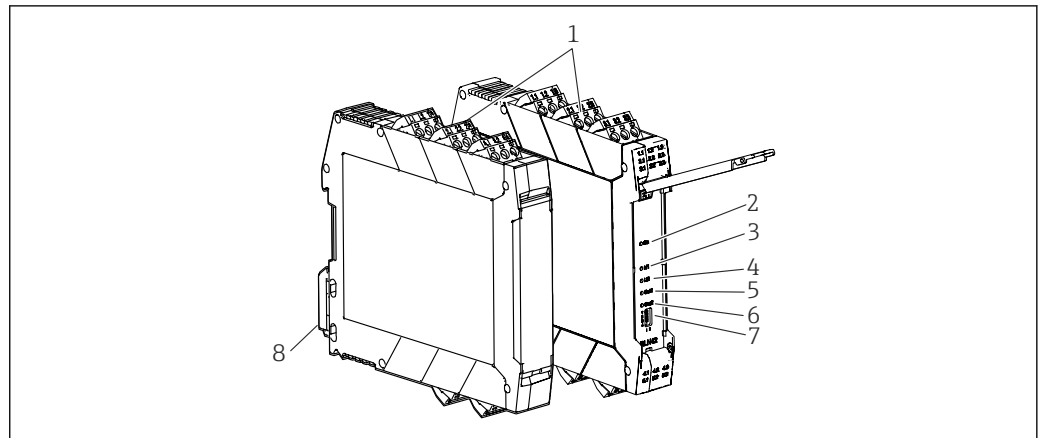

A0043446

10 Display and operating elements

- 1 Plug-in screw or push-in terminal
- 2 Green LED "On", power supply
- 3 Red LED "LF1", line fault of sensor cable 1
- 4 Red LED "LF2", line fault of sensor cable 2
- 5 Yellow LED "OUT1", status relay 1
- 6 Yellow LED "OUT2", status relay 2
- 7 DIP switches 1 to 4
- 8 DIN rail clip for DIN rail mounting

Local operation

Hardware settings / configuration

 Any device settings using the DIP switch must be made when the device is de-energized.

Direction of action

At the device, the direction of action (operating or closed circuit current behavior) can be selected and line fault detection can be enabled or disabled via DIP switches.

DIP switch 1 = channel 1; DIP switch 3 = channel 2

All DIP switches are set to the "I" position when the device is delivered from the factory:

- I = normal phase (operating current behavior)
- II = inverse phase (closed circuit current behavior)

DIP switch 1:

- DIP switch position I = normal function: in the event of a 0-signal at the input, the relay output (changeover) switches to the "non-conducting" state (NO contact is open) or "conducting" state (NC contact is closed).
- DIP switch position II = inverse function: in the event of a 1-signal at the input, the relay output (changeover) switches to the "non-conducting" state (NO contact is open) or "conducting" state (NC contact is closed).

Line fault detection

DIP switch 2 = channel 1; DIP switch 4 = channel 2

I = line fault detection switched off - **not permitted for safety-oriented applications!**

II = line fault detection switched on

If a line fault occurs, the relay is de-energized and the red LED "LF" flashes (NE 44).

NOTICE

Error detection malfunctions

- For switch contacts with an open circuit, line fault detection (LF) must be disabled or the corresponding resistance circuit (1 kΩ/10 kΩ) must be provided directly at the contact. (See the "Quick wiring guide" and "Accessories" sections of the Operating Instructions)

Truth table, 2-channel

Sensor at input			Input circuit	DIP switch Channel 1		DIP switch Channel 2		Output Relay contact	NC contact	LED		Permitted for safety-oriented applications
Switch	Contacts with resistive coupling elements	NAMUR		Status	1	2	3			4	OUT yellow	
Open	Open	Blocking	OK	I	I	I	I	Open	Closed			No
Closed	Closed	Conducting	OK	I	I	I	I	Closed	Open	X		No
Open	Open	Blocking	OK	II	I	II	I	Closed	Open	X		No
Closed	Closed	Conducting	OK	II	I	II	I	Open	Closed			No
	Open	Blocking	OK	I	II	I	II	Open	Closed			Yes
	Closed	Conducting	OK	I	II	I	II	Closed	Open	X		Yes
	Any state	Any state	Wire break	I	II	I	II	Open	Closed		X	Yes
	Any state	Any state	Short circuit	I	II	I	II	Open	Closed		X	Yes
	Open	Blocking	OK	II	II	II	II	Closed	Open	X		Yes
	Closed	Conducting	OK	II	II	II	II	Open	Closed			Yes
	Any state	Any state	Wire break	II	II	II	II	Open	Closed		X	Yes
	Any state	Any state	Short circuit	II	II	II	II	Open	Closed		X	Yes

12.10 Ordering information

Detailed ordering information is available for your nearest sales organization www.addresses.endress.com or in the Product Configurator under www.endress.com :

1. Click Corporate
2. Select the country
3. Click Products
4. Select the product using the filters and search field
5. Open the product page

The Configuration button to the right of the product image opens the Product Configurator.

Product Configurator - the tool for individual product configuration

- Up-to-the-minute configuration data
- Depending on the device: Direct input of measuring point-specific information such as measuring range or operating language
- Automatic verification of exclusion criteria
- Automatic creation of the order code and its breakdown in PDF or Excel output format
- Ability to order directly in the Endress+Hauser Online Shop

12.11 Accessories

Various accessories, which can be ordered with the device or subsequently from Endress+Hauser, are available for the device. Detailed information on the order code in question is available from your local Endress+Hauser sales center or on the product page of the Endress+Hauser website: www.endress.com.

Device-specific accessories

Type	Order code
Resistive coupling element, 1K/10K Ohm (x 1)	71505353



Service-specific accessories

Accessories	Description
Configurator	<p>Product Configurator - the tool for individual product configuration</p> <ul style="list-style-type: none"> ▪ Up-to-the-minute configuration data ▪ Depending on the device: Direct input of measuring point-specific information such as measuring range or operating language ▪ Automatic verification of exclusion criteria ▪ Automatic creation of the order code and its breakdown in PDF or Excel output format ▪ Ability to order directly in the Endress+Hauser Online Shop <p>The Configurator is available on the Endress+Hauser website at: www.endress.com -> Click "Corporate" -> Select your country -> Click "Products" -> Select the product using the filters and search field -> Open product page -> The "Configure" button to the right of the product image opens the Product Configurator.</p>
Accessories	Description
W@M	<p>Life cycle management for your plant</p> <p>W@M offers assistance with a wide range of software applications over the entire process: from planning and procurement to the installation, commissioning and operation of the measuring devices. All the relevant information is available for every measuring device over the entire life cycle, such as the device status, device-specific documentation, spare parts etc.</p> <p>The application already contains the data of your Endress+Hauser device. Endress+Hauser also takes care of maintaining and updating the data records.</p> <p>W@M is available: Via the Internet: www.endress.com/lifecyclemanagement</p>

12.12 Certificates and approvals

 For certificates and approvals valid for the device: see the data on the nameplate

 Approval-related data and documents: www.endress.com/deviceviewer → (enter the serial number)

Functional safety	<p>A SIL version of the device is optionally available. It can be used in safety equipment in accordance with IEC 61508 up to SIL 2.</p> <p> Please refer to Safety Manual FY01035K for the use of the device in safety instrumented systems according to IEC 61508.</p> <p> Protection against modifications:</p> <p>As it is not possible to disengage the operating elements (keys and DIP switches), a lockable control cabinet is required for use in SIL applications. The cabinet must be locked by key. A normal electrical cabinet key does not suffice for this purpose.</p>
-------------------	---

12.13 Documentation

The following document types are available in the Downloads section of the Endress+Hauser website (www.endress.com/downloads):

-  For an overview of the scope of the associated Technical Documentation, refer to the following:
- *W@M Device Viewer* (www.endress.com/deviceviewer): Enter the serial number from the nameplate
 - *Endress+Hauser Operations App*: Enter the serial number from the nameplate or scan the matrix code on the nameplate

Brief Operating Instructions (KA)	<p>Guide that takes you quickly to the 1st measured value</p> <p>The Brief Operating Instructions contain all the essential information from incoming acceptance to initial commissioning.</p>
-----------------------------------	---

Operating Instructions (BA)	<p>Your reference guide</p> <p>These Operating Instructions contain all the information that is required in various phases of the life cycle of the device: from product identification, incoming acceptance and storage, to mounting, connection, operation and commissioning through to troubleshooting, maintenance and disposal.</p>
-----------------------------	---

Safety Instructions (XA)	<p>Depending on the approval, the following Safety Instructions (XA) are supplied with the device. They are an integral part of the Operating Instructions.</p> <p> The nameplate indicates the Safety Instructions (XA) that are relevant to the device.</p>
--------------------------	--

Supplementary device-dependent documentation	<p>Additional documents are supplied depending on the device version ordered: Always comply strictly with the instructions in the supplementary documentation. The supplementary documentation is an integral part of the device documentation.</p>
--	---

13 Appendix: system overview of RN Series

13.1 Power supply of RN Series

13.1.1 General information on the power supply of Endress+Hauser isolating amplifiers

 Read the information leaflet enclosed in the package of the individual products.

13.1.2 Power supply options of RN4x Series (24 to 230 V)

The RN42 active barrier and RLN42 NAMUR isolating amplifier are available with an extended supply voltage range of 24 to 230 V_{AC/DC}. These modules are powered individually and exclusively via the terminals on the device and are **not** suitable for power supply via the DIN rail bus connector.

13.2 Applications of the isolating amplifiers

This section describes the typical applications of the devices.

These devices perform various functions during signal conditioning:

- Amplification
- Normalization
- Filtering
- Galvanic isolation
- Supply of electrical power to connected sensors
- Line monitoring

The devices for these tasks are collectively known as isolating amplifiers or signal isolators and are available with different functions in the Endress+Hauser RN Series. Different types of signals are conditioned in this context.

13.2.1 Types of signals

Signals are referred to as **analog** signals if they can continuously assume every value between a minimum and maximum value (e.g. 0/4-20 mA) and are therefore also known as "value-continuous" signals. The value range in this interval is huge and is practically infinite in terms of measuring accuracy.

Electrical analog signals are generated with the help of a sensor, for example, which records the states, or changes of state, of physical variables and converts them to an electrical signal.

The following variables are typically measured in system and process engineering using Endress+Hauser measuring devices:

- Temperature
- Pressure
- Level
- Total flow
- Analysis values (e.g. turbidity, conductivity, pH etc.)

These analog signals are evaluated in the controller (PLC) and the signals can be used in a "target device": e.g. for

- Display devices, e.g. level indication via RIA15
- Control unit, e.g. level control
- Actuators, e.g. to fill a tank

A transmitter can also be connected downstream of the sensor. This transmitter converts the analog measured value signal to a standard signal and thereby enables the further processing of the signal with additional standardized, electrical modules. The transmitter can also be integrated in the sensor housing.

Binary signals only assume two values and signal the states "on" or "off" / "1" or "0" with these values. Binary signals are often equated with "digital" signals because digital signals are generally binary encoded.

HART (Highway Addressable Remote Transducer) signals are essentially characterized by the fact that they are operated and used as a complement to classic analog standard signals, in contrast to other digital fieldbus systems. HART therefore does not replace point-to-point wiring but rather enables the integration of smart field devices. The digital signals are modulated onto an analog 4 to 20 mA standard current signal by means of HART modulation in order to transmit digital information in addition to the analog information of the process value.

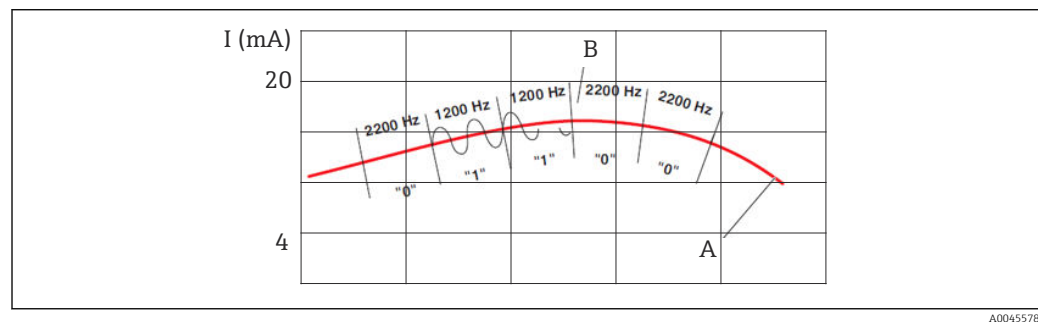

11 Modulated HART signal

A Analog signal

B Digital signal

NAMUR sensors are operated with a transmitted current and have four states so that sensor errors can also be detected by an analog evaluation unit. This is sometimes referred to as the "closed circuit current principle".

NAMUR sensors can adopt four states at the output:

- Current 0 mA: wire break; circuit open
- Current <1.2 mA: sensor ready, undamped
- Current >2.1 mA: sensor ready, dampened
- Current maximum value >6 mA: short-circuit, maximum current

The portfolio of the RN Series offers the following function modules:

- RN22, RN42 active barrier
- RN22 signal doubler
- RLN22, RLN42 NAMUR isolating amplifier
- RNO22 output isolating amplifier

13.2.2 RLN42 NAMUR isolating amplifier

The NAMUR isolating amplifiers isolate and convert the analog NAMUR signal of connected proximity or limit switches to binary relay output states.

The abbreviation "NAMUR" is based on the former association name "Normen Arbeitsgemeinschaft für Mess- und Regeltechnik in der chemischen Industrie (Standardization Association for Measurement and Control in Chemical Industries)". While NAMUR's subtitle has since changed, the abbreviation has been kept. NAMUR sensors are proximity sensors or limit switches that are widely used in process automation. Endress+Hauser offers capacitance, conductive and vibronic sensors for the various applications. The electrical properties of sensors according to the NAMUR standard and their measuring characteristics are standardized. Therefore, they are vendor-independent and replacement is not restricted to the products of a specific vendor. NAMUR sensors are short-circuit

proof. A short-circuit and line break in the sensor line can be detected by the RLN42 evaluating unit. A NAMUR sensor does not need a separate power supply: its power is supplied via the measuring circuit.

The operating voltage of the field loop in the "NAMUR measuring circuit" should be at 8 ± 1 volt, the load on short-circuit should be between 100 to 360 Ω .

NAMUR sensors are operated with a transmitted current and have four states so that sensor errors can also be detected by an analog evaluation unit. This is sometimes referred to as the "closed circuit current principle".

NAMUR sensors can adopt four states at the output:

- Current 0 mA: wire break; circuit open
- Current <1.2 mA: sensor ready, undamped
- Current >2.1 mA: sensor ready, dampened
- Current maximum value >6 mA: short-circuit, maximum current

A common application of NAMUR sensors is limit value monitoring in process automation. For this, analog signals are often only evaluated in a binary manner for a controller, e.g. if the application involves monitoring the level in a tank or monitoring a temperature, whereby a counteraction should be triggered if a limit value is exceeded. Here, the temperature currently measured can only be used to determine whether the temperature is above or below the limit value, for example.

The following are examples of typical applications of the RLN42 NAMUR isolating amplifier. Each application is explained briefly and described in a schematic diagram.

Example: digital isolating amplification of NAMUR sensor signals from a hazardous area

- The passive Liquiphant FTL41 sensor with FEL48 evaluation unit supplies a NAMUR signal value of 1.2 mA or 2.1 mA to the active input of the isolating amplifier
- The RLN42 NAMUR isolating amplifier supplies a binary output signal (relay contact), which depends on the input signal, to a digital input of the controller
- Line breaks or short-circuits of the 2-wire sensor line are indicated by LEDs on the RLN42

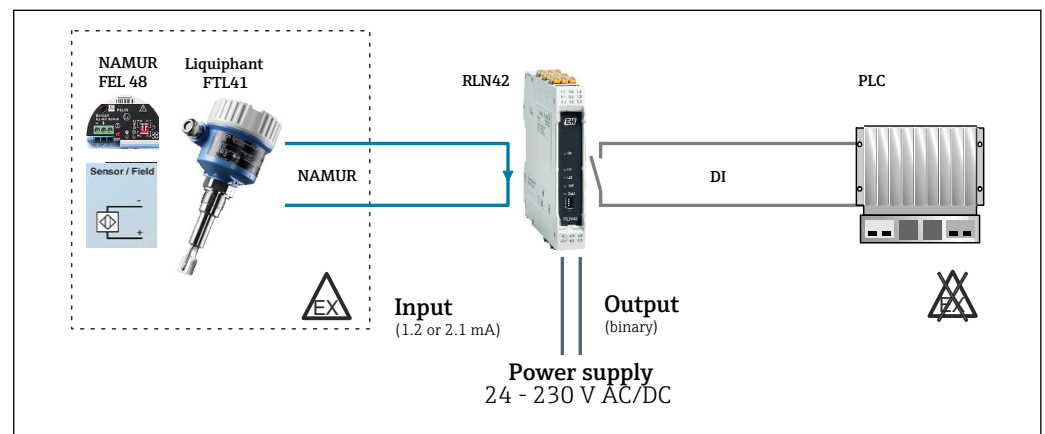

12 NAMUR limit detection, Liquiphant FTL41 with FEL48 NAMUR evaluation in the hazardous area

Example: digital isolating amplification of sensors with mechanical contacts from a hazardous area

- The FTE20 rotary paddle switch reports the state via a mechanical switching contact
- The sensor and the connecting cables are monitored for line breaks and short-circuiting via the resistive coupling element, which is available as an accessory for the RLN42
- The RLN42 NAMUR isolating amplifier supplies a binary output signal, which depends on the input signal, to a digital input of the controller
- Line breaks or short-circuits of the 2-wire sensor line are indicated by LEDs on the RLN42

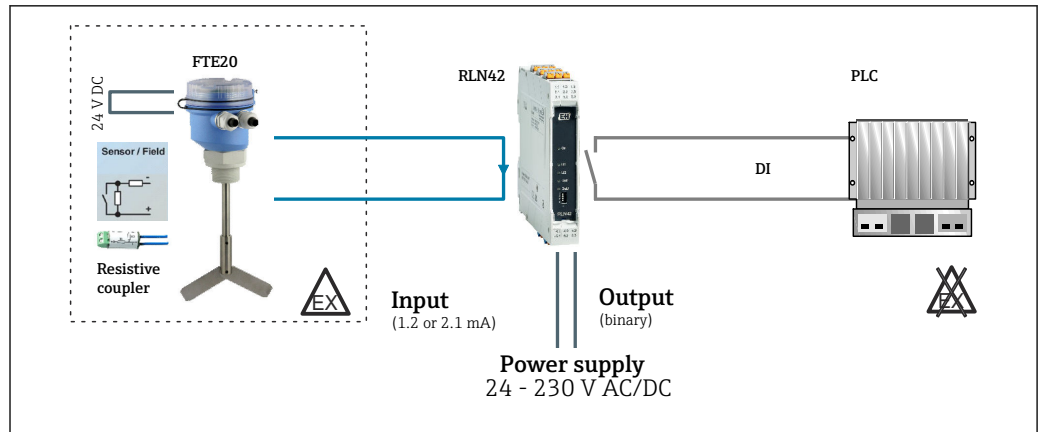

A0045924

13 NAMUR limit detection with FTE20 paddle switch with line monitoring in the hazardous area

Line monitoring for line breaks and short-circuiting can be implemented with the resistive coupling element (can be optionally ordered for the RLN42 NAMUR isolating amplifier), which is looped into the connection compartment of the FTE20 on the sensor side. This monitoring function is described in greater detail in the NE21 Recommendations (User Association of Automation Technology in Process Industries (NAMUR)).

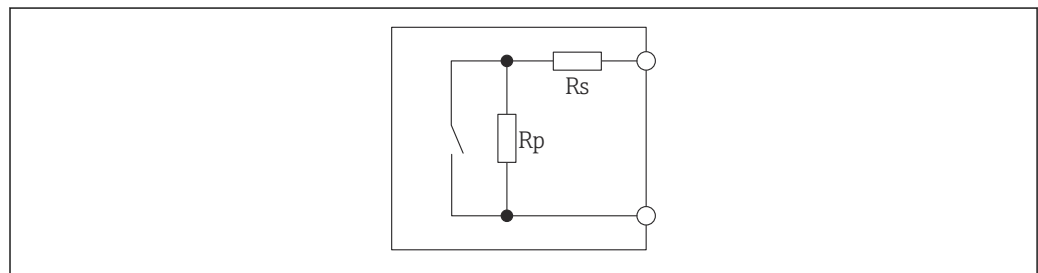

A0045584

14 Resistance circuit for line monitoring (short-circuit and line break)

R_s 1 k Ω
 R_p 10 k Ω

Index

A

- Accessories
 - Device-specific 25

C

- CE mark 6

D

- Declaration of Conformity 6
- Device documentation
 - Supplementary documentation 26
- DIP switches 13, 23
- Display and operating elements
 - Overview 13, 23
- Document
 - Function 3
- Document function 3

H

- Hardware settings
 - Configuration 13, 23

L

- Line fault detection 13, 23

N

- Nameplate 7

O

- Operation options
 - Local operation 13, 23
- Operational safety 5

P

- Product safety 6

R

- Requirements for personnel 5
- Return 17

S

- Safety Instructions (XA) 26

T

- Terminal assignment 12, 19
- Troubleshooting
 - General faults 16

W

- Workplace safety 5



71543133

www.addresses.endress.com
