



Proline
simply clever

Tap to navigate

Proline in industries

Innovative products for your business

Proline Added Values

Simply clever

Netilion

The multi-brand ecosystem

Proline simply clever

Endress+Hauser 

Proline in Life Sciences

Proline 100



Promass P 100

Promass P 100

The specialist for sterile processes with an ultra-compact transmitter

For biotech applications requiring highest compliance and for modular, skid-mounted process facilities

- Optimized calibration due to Heartbeat Technology
- Full audit safety – industry-compliant design (ASME BPE), documentation and approvals
- Fully self-drainable, even in horizontal installations
- Highest process safety – all stainless steel wetted parts with electropolished surface finish
- Multivariable measurement through Ethernet connectivity
- Quality by design – fully compliant self-verification at any time

Available Added Values with Promass P 100



Proline 100

Proline 100

Transmitter versions

The ultra-compact transmitter delivers full performance on the smallest footprint and enables seamless system integration, making it the preferred choice for skid builders, equipment manufacturers and system integrators. Heartbeat Technology enables compliance and process safety at all times.

Additional information



Compact housing



Ultra-compact housing with plug connectors



Optional with local display

Promass P

Promass P

Sensor

Promass P is the specialist for sterile processes and dedicated to biotech applications requiring highest compliance with guidelines and regulations. The Coriolis flowmeter is fully self-drainable even in horizontal installation.

Approvals

EHEDG

EHEDG-certified devices enable a safe, hygienic production

ASME BPE

Full documentation ensuring traceability and compliance

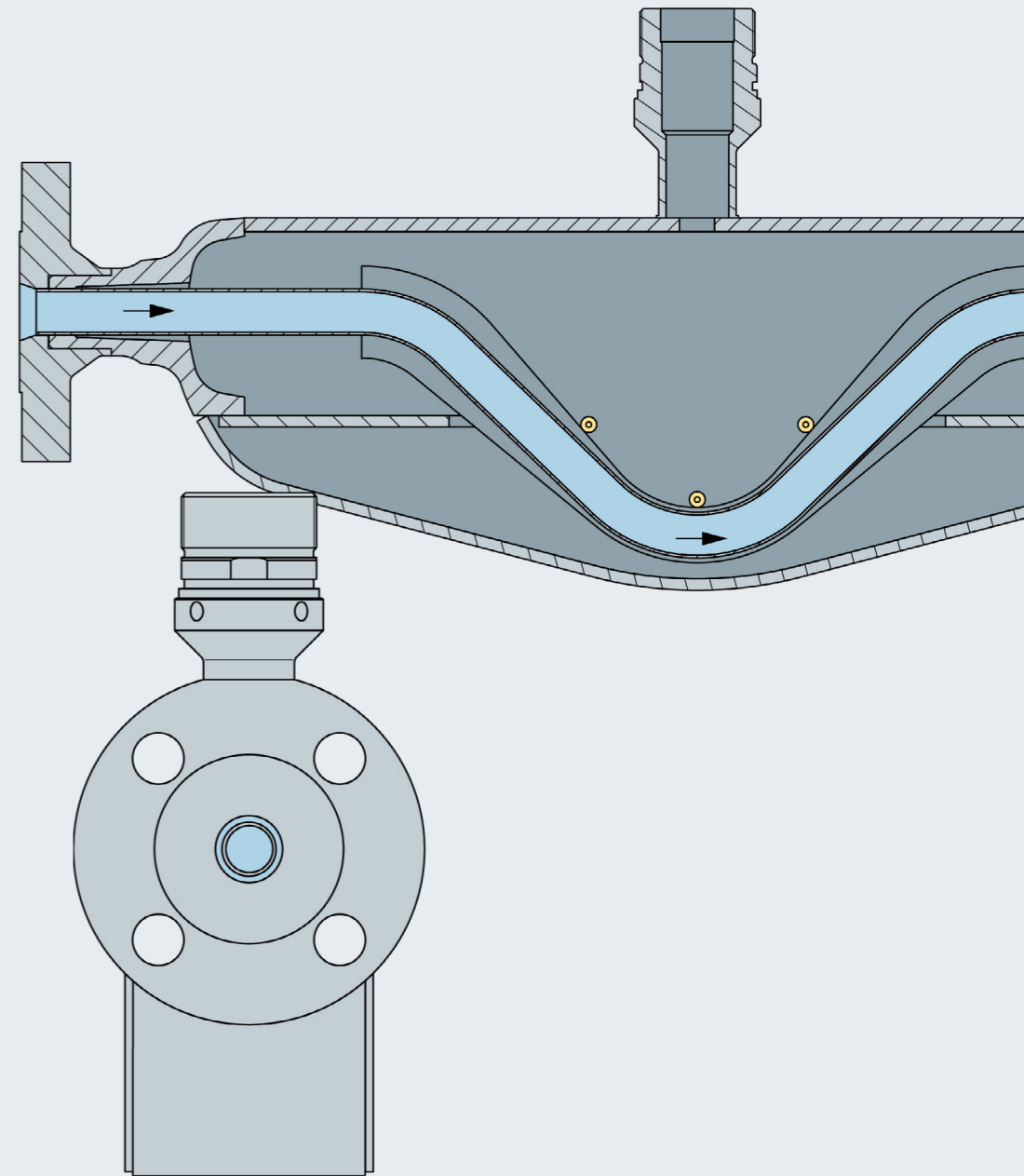

Promag H 100

Promag H 100

Cost-effective volumetric flowmeter with an ultra-compact transmitter

For a broad range of standard applications with conductive fluids and modular, skid-mounted process facilities

- Optimized calibration due to Heartbeat Technology
- Flexible – numerous hygienic process connections
- Multivariable measurement: volume flow, temperature, conductivity
- Fulfills internal and external regulatory requirements: FDA compatibility (USP Class VI)
- Multivariable measurement through Ethernet connectivity
- Quality by design – fully compliant self-verification at any time

Available Added Values with Promag H 100



Proline 100

Proline 100

Transmitter versions

The ultra-compact transmitter delivers full performance on the smallest footprint and enables seamless system integration, making it the preferred choice for skid builders, equipment manufacturers and system integrators. Heartbeat Technology enables compliance and process safety at all times.

Additional information



Compact housing



Ultra-compact housing with plug connectors



Optional with local display

Promag H

Promag H

Sensor

This magmeter is the cost-effective solution for standard applications with conductive fluids. With its numerous process connections, Promag H provides a flexible installation concept.

Approvals

Hygienic approvals

3-A, EHEDG, liner and seals according to FDA

Hazardous area approvals

ATEX, IECEx, cCSAus, INMETRO

Various process connections are available with Promag H:

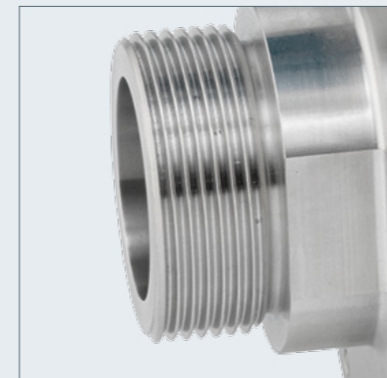

Threads



Tri-Clamps

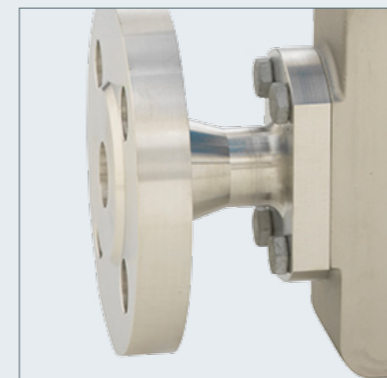

Flanges



Welding nipples

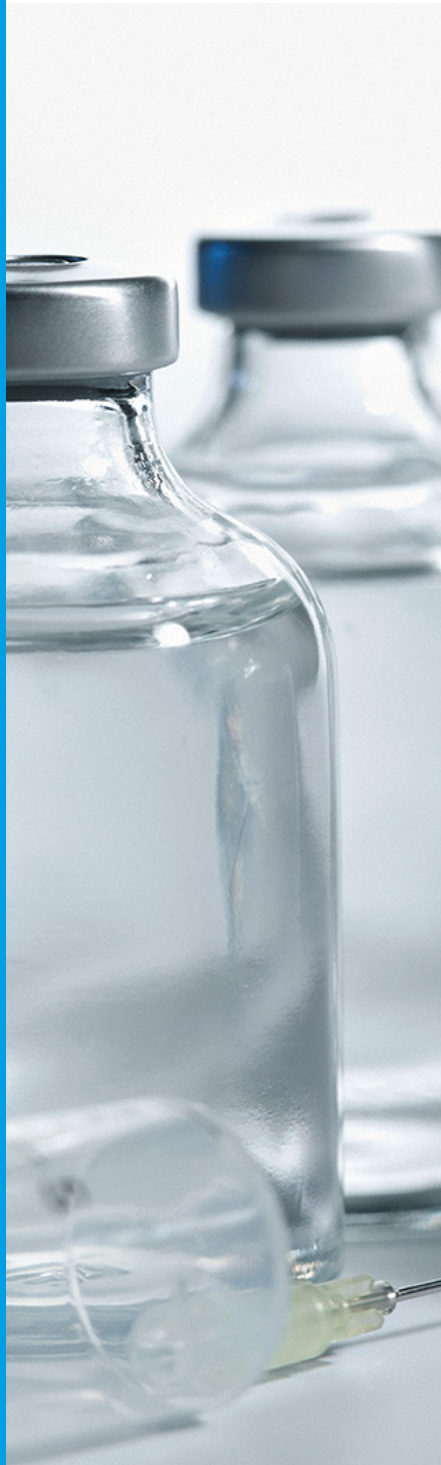

Industry needs **Compliance**

Compliance

ASME BPE standard

In order to fulfill regulatory compliance and ensure product quality, users are forced to perform regular, traceable device calibrations. Calibrations, however, are costly, time-consuming, cause process downtime and additionally pose an increased risk of contamination due to broken process seals.

Our solution Only devices specifically designed for the life science industries provide full regulatory (GMP) compliance. A comprehensive set of documents and certificates enables that all the paperwork required for a successful audit is readily available.

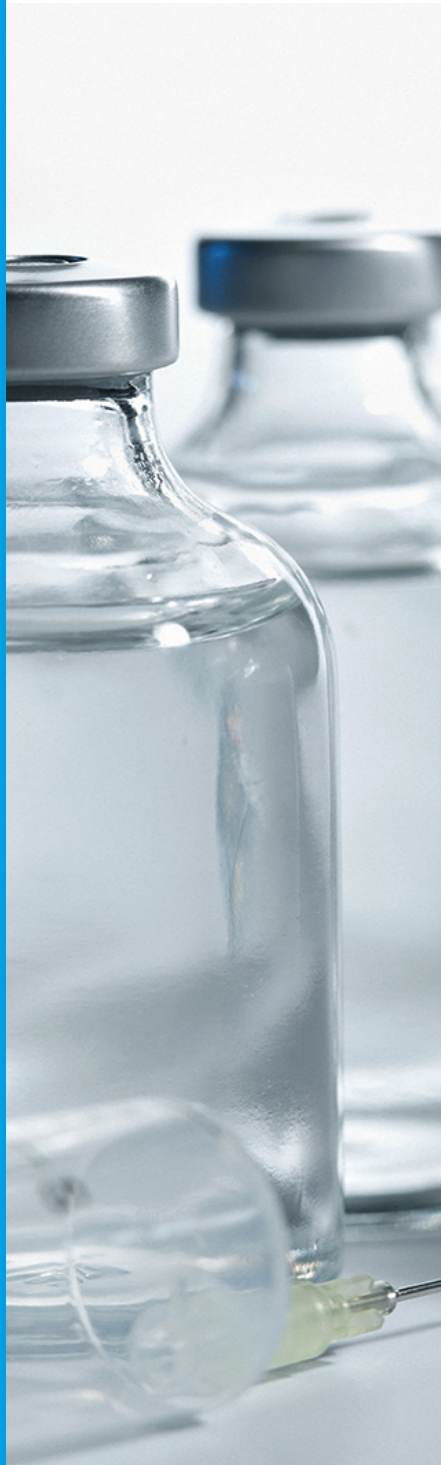

Industry needs

Quality by design

Quality by design

Calibration and verification

Validation and qualification are important steps in the life cycle of any piece of processing equipment. When deciding on a specific supplier, equipment qualification in the context of quality management or validation is an essential requirement for a large number of companies.

Our solution Integrated functionalities such as Heartbeat Technology facilitate the implementation of "Quality by Design" (QbD) and provide full regulatory compliance. They offer the possibility of reducing or even eliminating wet calibrations without putting product quality at risk.

Additional information



**Proline in
Food & Beverage**
Proline 100



Promag H 100

Promag H 100

Proven specialist for the food and beverage industry

For demanding hygienic applications and for modular, skid-mounted process facilities

- Meets all industry requirements (3-A, EHEDG)
- Multivariable measurement: volume flow, temperature, conductivity
- Fulfills process connection standards – numerous hygienic process connections
- Space-saving installation, IP69 ingress protection
- Time-saving commissioning via integrated web server
- Multivariable measurement through Ethernet connectivity
- Optimized calibration intervals – integrated Heartbeat Technology

Available Added Values with Promag H 100



Proline 100

Proline 100

Transmitter versions

The ultra-compact transmitter provides full performance and compliance on the smallest footprint and enables seamless system integration, making it the preferred choice for skid builders, equipment manufacturers and system integrators. Heartbeat Technology enables process safety at all times.

Additional information



Compact housing



Ultra-compact housing with plug connectors



Optional with local display



Promag H

Promag H

Sensor

The fully industry-compliant Promag H is the specialist for all demanding hygienic applications. With its numerous process connections, the magmeter meets a wide variety of customer requirements.

Approvals

Hygienic approvals
3-A, EHEDG

Various process connections are available with Promag H:

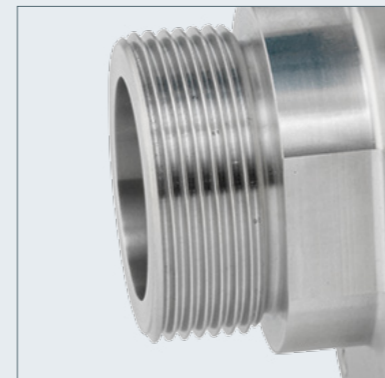

Threads



Tri-Clamps

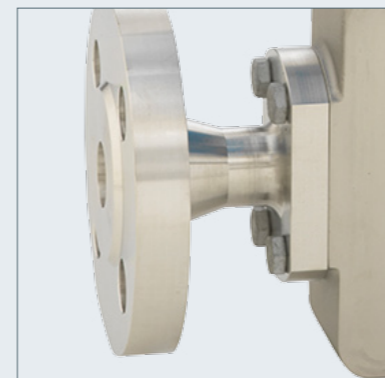

Flanges



Welding nipples



Promass S 100



Promass S 100

Hygienic single-tube flowmeter with an ultra-compact transmitter

Dedicated to applications requiring optimal cleanability and gentle fluid treatment under hygienic conditions

- Meets all industry requirements (3-A, EHEDG)
- Multivariable measurement through Ethernet connectivity
- Improved product quality – careful treatment of fluids due to single-tube design
- Large range of hygienic process connections
- Less downtime – immediate availability after CIP/SIP
- Space-saving installation, degree of protection IP69
- Time-saving commissioning via integrated web server
- Optimized calibration intervals – integrated Heartbeat Technology

Available Added Values with Promass S 100



Proline 100

Proline 100

Transmitter versions

The ultra-compact transmitter provides full performance and compliance on the smallest footprint and enables seamless system integration, making it the preferred choice for skid builders, equipment manufacturers and system integrators. Heartbeat Technology enables process safety at all times.

Additional information



Compact housing



Ultra-compact housing with plug connectors



Optional with local display



Promass S



Promass S

Sensor

The Promass S Coriolis sensor is at the forefront in hygienic design and dedicated to applications requiring optimal cleanability. The self-drainable single-tube system ensures careful treatment of fluids.

Approvals

Hygienic approvals

3-A, EHEDG

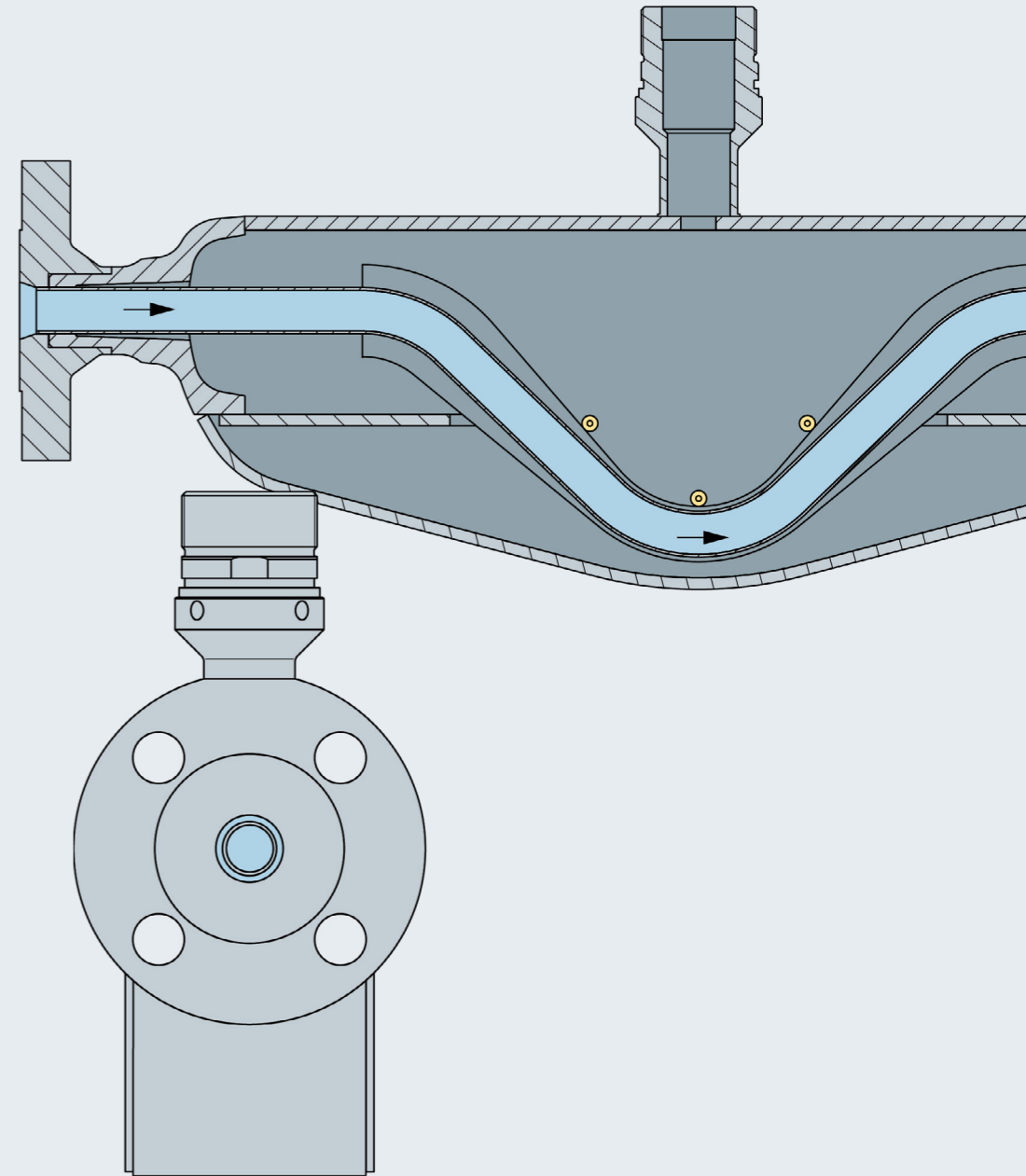

Industry needs **Compliance**

Compliance

Best-fit products and documentation

Users have to fulfill the legal requirements of the food and beverage industry, and need all food-relevant sensor certifications, e.g., 3-A, EHEDG, FDA, EC 1935/2004, GB 4806 and PMO (Pasteurized Milk Ordinance). Complete and correct documentation is essential for audits.

Our solution Our basket of industry-optimized, 3-A and EHEDG approved measuring solutions reduces work for risk assessment. Application- or device-related documentation such as certificates and calibration protocols are available, saving resources and time.



Industry needs

Proven reliability

Proven reliability

Calibration and verification

In order to fulfill the industry requirements of quality and traceability, the user is forced to perform periodic verifications and calibrations of his plant equipment. This has to be done at minimum cost and in the minimum of time.

Our solution Each device is tested on accredited calibration rigs. We offer traceable calibration of measuring equipment according to ISO 17025 on site or in Endress+Hauser facilities. In-situ verification (ISO 9001) is possible at any time without time-consuming process interruption, ensuring constant food quality.

Additional information

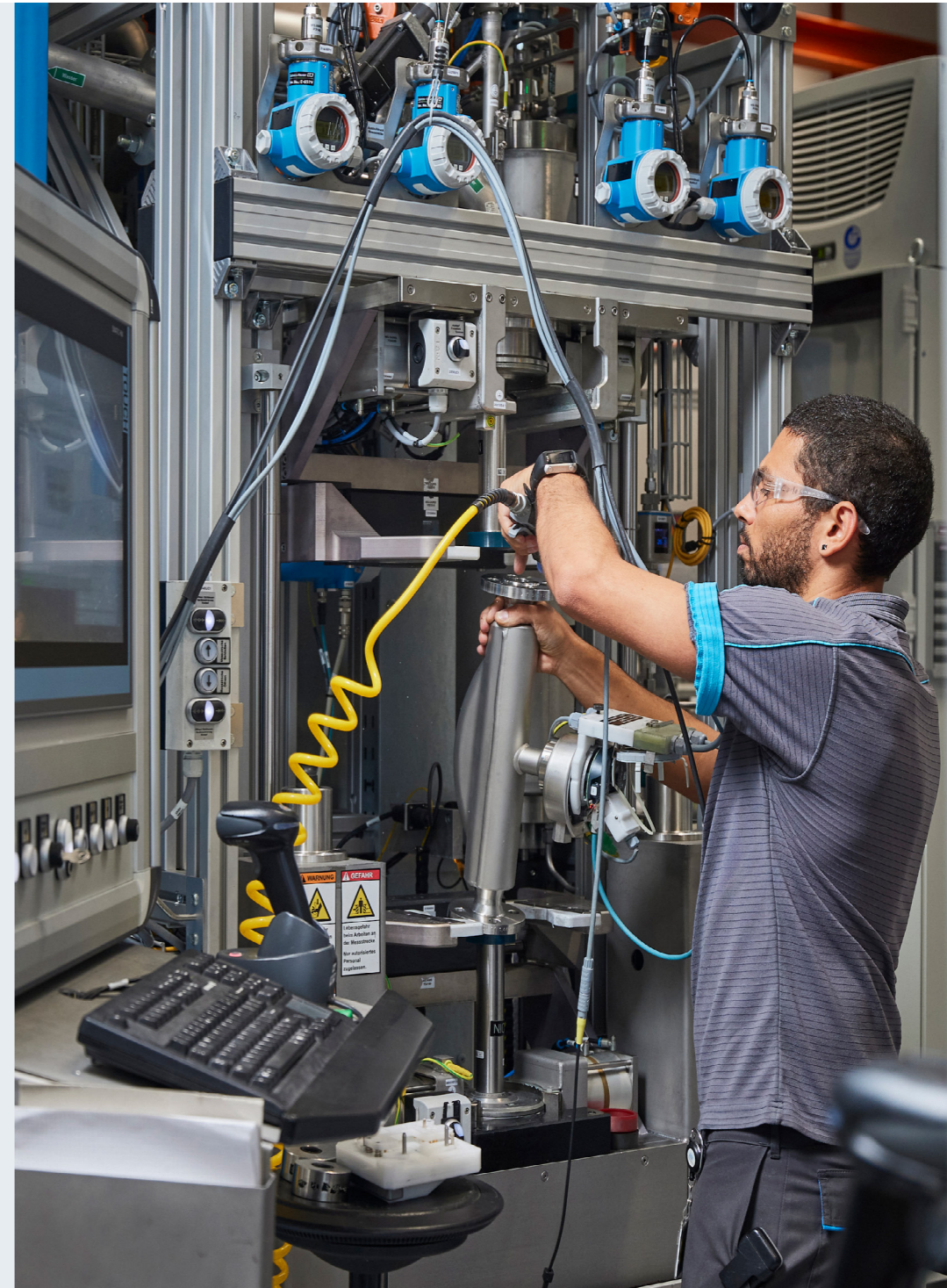

Proline simply clever

Endress+Hauser 

Proline in Chemical

Proline 200



Promass F 200

Promass F 200

Genuine loop-powered, robust and proven Coriolis flowmeter

Highest measuring performance for liquids and gases in a wide range of applications

- Highest process safety – pressure-rated sensor housing, purge connections and rupture disks
- Optimal process safety – dedicated wetted parts for chemical and process applications
- Space-saving installation – no inlet/outlet run requirements
- Reliable data – developed as per IEC 61508, with NAMUR NE107 clear text diagnostics
- Safe operation – simplified access and maintenance in hazardous areas due to intrinsically safe design

Available Added Values with Promass F 200



Proline 200

Proline 200 Transmitter

With genuine loop-powered technology, Proline 200 enables cost-effective and seamless integration into existing infrastructures. It offers highest operational safety in hazardous areas thanks to its intrinsically safe design (Ex ia). In addition, process safety is enhanced by Heart-beat Technology.



Promass F

Promass F

Sensor

Promass F has a long-standing reputation as a highly accurate Coriolis sensor for universal flow measurement of liquids and gases in a wide range of applications.

Approvals

Hazardous area approvals

ATEX, IECEx, cCSAus, INMETRO, NEPSI, TIIS

Functional safety

Developed according to IEC 61508 (SIL 2/3)

Safety by design

- Pressure-rated sensor housing for increased safety
- Wetted parts in 904L (1.4539) or Alloy C22

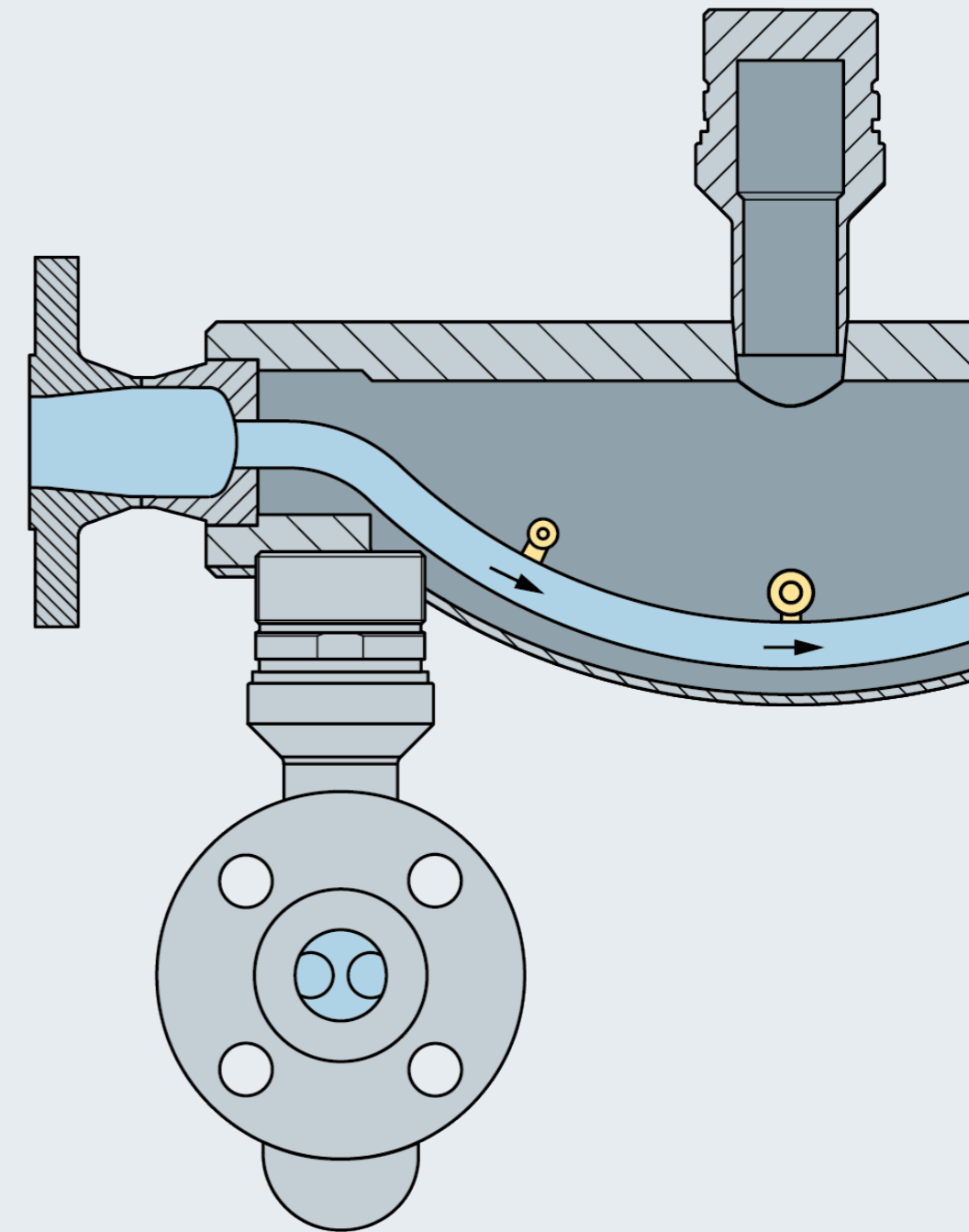

Prowirl F 200

Prowirl F 200

Vortex flowmeter with mass flow output, available as compact or remote version

Suitable for a wide range of applications; optimized for steam measurement (including wet steam)

- Multivariable measurement – optionally available with integrated pressure cell and temperature sensor
- Optimal availability – robust, resistance to vibrations, temperature shocks and water hammer
- Accurate values in critical applications – dualsensors version enabling redundant measurement, suitable for SIL 3
- Simple system integration via PROFINET with Ethernet-APL
- Safe operation – simplified access and maintenance in hazardous areas due to intrinsically safe design

Available Added Values with Prowirl F 200



Proline 200

Proline 200 Transmitter

With genuine loop-powered technology, Proline 200 enables cost-effective and seamless integration into existing infrastructures. It offers highest operational safety in hazardous areas thanks to its intrinsically safe design. In addition, process safety is enhanced by Heartbeat Technology.



Prowirl F

Prowirl F Sensor

Prowirl F is the multivariable flowmeter with in-line wet steam measurement. Its calibration option "PremiumCal" guarantees excellent measuring accuracy and highest plant availability at low flow rates of gas, steam and liquids.

Approvals

Hazardous area approvals

ATEX, IECEx, cCSAus, INMETRO, NEPSI, JPN

Functional safety

According to IEC 61508, applicable in safety-relevant applications in accordance with IEC 61511



Industry needs **Unbeatable**

Unbeatable

SIL and Heartbeat Technology

In the chemical industry, safety devices must be regularly tested to ensure their safety function (SIL). Such proof tests are often time-consuming and costly, particularly for continuously measuring systems.

Our solution Our current Proline flowmeter generation is equipped with Heartbeat Technology, allowing you to extend proof-test intervals. The embedded self-monitoring functionality, featuring secure verification reports according to IEC 61511-1, enables partial proof-testing without interrupting operation.

Additional information



Industry needs

Efficient

Efficient

Loop-powered technology

Round-the-clock operational safety and plant availability are particularly important in the chemical industry. In addition, plant operators face increasing complexity due to the numerous measuring tasks.

Our solution By using our uniform 4–20 mA loop-power concept for all measuring technologies, you can increase operational reliability and reduce costs for planning, purchasing and operation. Developed according to IEC 61508 (SIL) and intrinsically safe. Designed with safety as first priority.

Additional information



Proline simply clever

Endress+Hauser 

Proline in
Water & Wastewater



Promag W 400



Promag W 400

Versatile standard device with lap-joint or welded flanges and highest industry compliance

Widely applicable, e.g., in water networks, wastewater treatment, desalination

- Certified for direct underground installation or permanent underwater use
- Reliable long-term operation – robust and completely welded sensor
- Legal compliance – worldwide accepted drinking water approvals
- Flexible engineering – sensor with 0 x DN inlet and outlet runs
- Safe operation – no need to open the device due to display with touch control and background lighting
- Time-saving local operation without additional software and hardware via WLAN – integrated web server

Available Added Values with Promag W 400



Additional information

Proline 400

Proline 400 Transmitter

Promag 400 saves time and costs thanks to the broad functionality of its transmitter optimized for Water & Wastewater. In addition, Heartbeat Technology enables compliance and process safety at all times.

Additional information



Promag W

Promag W

Sensor

Promag W is the preferred flowmeter for all water and wastewater applications. Due to its liner variety and drinking water approvals, Promag W offers highest compliance to the water and wastewater industry.

Approvals

Drinking water approvals

ACS, KTW/W270, NSF 61, WRAS BS 6920

Custody transfer approvals

OIML Class 1 / OIML Class 2, MI-001

Promag W is available with lap-joint flanges and welded flanges as well as with certified corrosion protection.



Prosonic Flow B 200

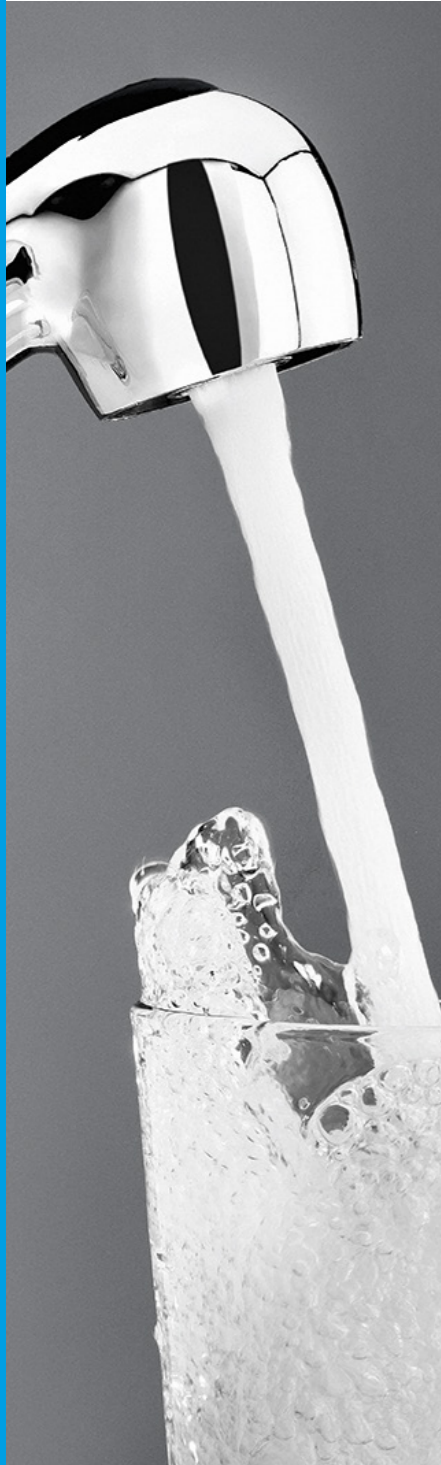

Prosonic Flow B 200

For accurate, reliable biogas measurement

Inline flowmeter designed for digester gas, wet biogas and landfill gas under fluctuating process conditions

- Easy and transparent energy balancing:
 - Direct measurement of the methane content in the pipe
 - Calculation of additional characteristic values such as corrected volume, calorific value or Wobbe index
- Specialized sensor design for low pressure gases
- No pressure loss – full-bore design
- Highly reliable due to Heartbeat Diagnostics and Verification function
- Optimized calibration cycles – integrated Heartbeat Technology
- Convenient device wiring – separate connection compartment

Available Added Values with Prosonic Flow B 200



Additional information

Proline 200

Proline 200

Transmitter

With genuine loop-powered technology, Proline 200 enables cost-effective and seamless integration into existing infrastructures. It offers highest operational safety in hazardous areas thanks to its intrinsically safe design (Ex ia). Furthermore, process safety is enhanced by Heart-beat Technology.



Prosonic Flow B

Prosonic Flow B

Sensor

The ultrasonic device is the specialist for accurate, reliable measurement of digester gas and wet biogas, even under fluctuating process conditions. With its unique integrated methane concentration measurement, Prosonic Flow B enables continuous measurement of gas flow as well as gas quality.



Industry needs [Web server](#)



Intuitive, time-saving operation

Web server

A common requirement in water and wastewater applications is that operation should be as simple as possible. Similarly, non-specialist technicians should be able to commission and replace devices.

Our solution Proline web server gives quick access to device, diagnostics and process information. A standardized, user-intuitive "human-machine interface" with guided parameterization reduces complexity of operation.

Additional information



Industry needs

Guaranteed lifetime

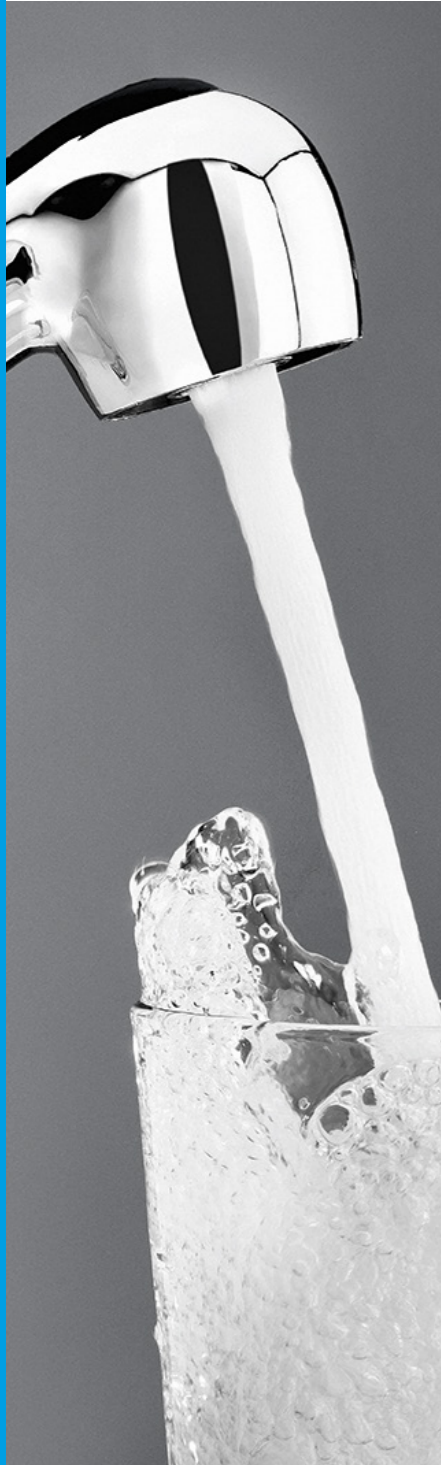

Guaranteed lifetime

Reliable long-term operation

For outdoor installations, devices must be able to withstand heat, dust or extreme climatic fluctuation. For continuous underwater or underground use, they must be corrosion-resistant and watertight. Where water quality is involved, high accuracy and reliability are absolutely essential.

Our solution Certified Proline devices are designed to be the best fit for your application. In addition, Heartbeat Technology enables continuous diagnostics and comprehensive device verification (e.g., for predictive maintenance), extends in-line calibration intervals and fulfills ISO 9001 traceability requirements.

Additional information



Proline simply clever

Endress+Hauser 

Proline in
Oil & Gas



Promass Q 300

Promass Q 300

Specialist for challenging applications with unmatched accuracy and compact transmitter

Highest measuring performance for custody transfer, mass, volume flow and density in challenging applications

- Optimized performance for liquids with entrained gas – MFT (Multi-Frequency Technology)
- Multivariable measurement – mass and volume flow, density, temperature, entrained gas detection
- Space-saving installation – no inlet/outlet run requirements
- Flexibility in terms of operation – compact, robust design, freely combinable I/Os, Ethernet and fieldbuses
- Easy and fast commissioning and maintenance – WLAN communication
- Best-in-class diagnostics coverage – developed according to IEC 61508

Available Added Values with Promass Q 300



Proline 300

Proline 300

Transmitter

The compact transmitter offers high flexibility in terms of operation and system integration: access from one side, remote display and improved connectivity options. Heartbeat Technology enables compliance and process safety at all times.

Additional information



Promass Q

Promass Q

Sensor

Promass Q provides the highest measuring accuracy for mass flow, volume flow and density. Being the preferred choice for custody transfer applications, it has also been optimized for liquid applications where entrained gas is known to be present.

Approvals

Custody transfer approvals

OIML-R117, MI-005, etc.

Pressure-temperature rating

Group 1.1 acc. to ASME B16.5-2017

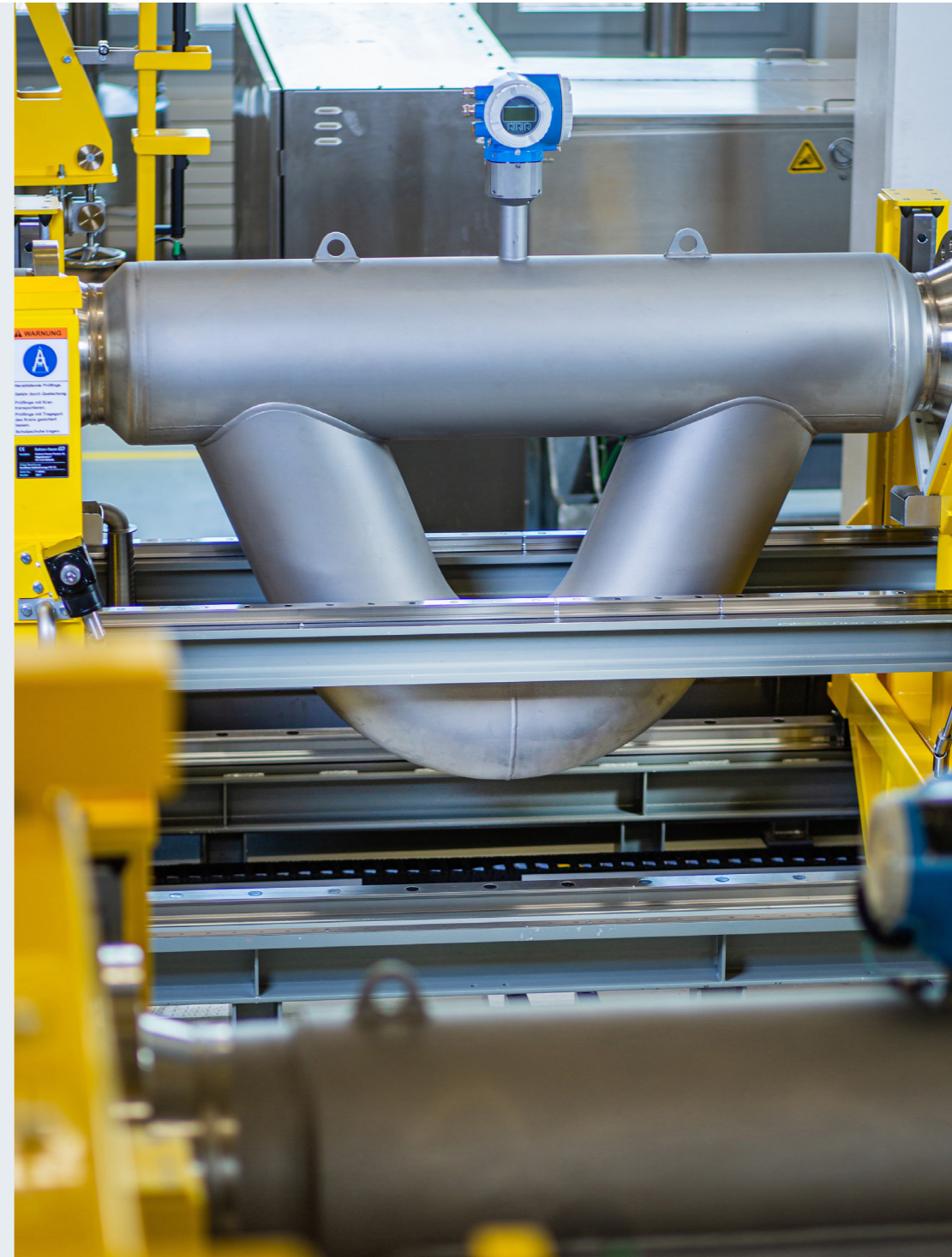

Prowirl O 200

Prowirl O 200

Robust, high-pressure flowmeter as compact or remote version

The specialist for liquids, natural gas and steam in applications with very high process pressure

- Reduced operating costs – Heartbeat Technology
- Highest mechanical integrity even at highest process pressures – special measuring tube material
- High availability – proven robustness, resistance to vibrations, temperature shocks and water hammer
- No maintenance – lifetime calibration
- Safe operation – no gas testing due to intrinsically safe design
- Fast commissioning – uniform HMI concept
- Best-in-class diagnostic coverage (IEC 61508)

Available Added Values with Prowirl O 200



Additional information



Proline 200

Proline 200 Transmitter

With genuine loop-powered technology, Proline 200 enables cost-effective and seamless integration into existing infrastructures. It offers highest operational safety in hazardous areas thanks to its intrinsically safe design (Ex ia). Furthermore, process safety is enhanced by Heart-beat Technology.



Prowirl O

Prowirl O

Sensor

Prowirl O is ideally suited for gas and steam applications with very high process pressure. Its immunity to vibrations, temperature shocks and water hammer allows a reliable vortex flow measurement even under challenging process conditions.



Industry needs **Safe plant operation**

Safe plant operation Heartbeat Technology

Safety in the oil and gas industry prevents damage to your infrastructure and even the environment. Therefore, qualified partners who understand far more than the basics are absolutely essential for the success and safety of operations.

Our solution Our devices are equipped with the application-proven Heartbeat Technology. Its integrated diagnostic, verification and monitoring functionalities detect irregularities by use of redundant internal references, providing reliable and safe operations.

Additional information



Industry needs

Improved ROI

Improved ROI

Production optimization

Users strive to get the most out of production equipment. Whether it is operating offshore or onshore – production control, energy costs and maintenance create daily challenges that must be considered when optimizing production.

Our solution Endress+Hauser's dedicated product portfolio helps maintain the safe and efficient operation that is essential to the industry. Devices compliant to standards such as ASME, NACE, CRN and NORSOK reduce operational costs and optimize production.

Additional information



Industry needs

Best-fit products

Best-fit products

For clean energy

Global demand for clean and green energy continues to rise. Oil and gas companies strive to achieve net-zero emission by 2050. An optimum process control is key, e.g., for accounting, fiscal metering or precise, industry-compliant monitoring of mass and volume flows.

Our solution We support our customers with state-of-the-art measuring technology for clean energy (e.g., LNG, hydrogen) and for monitoring CO₂ in carbon capture, utilization and storage (CCUS) to reduce CO₂ emission.

Additional information



Proline simply clever

Endress+Hauser 

Proline in Mining, Minerals & Metals
Proline 300



Promag P 300

Promag P 300

Magmeter with highest accuracy and a compact, easily accessible transmitter

Fit for demanding industrial applications, e.g., in mineral processing, steel works, for highest safety as well as chemically aggressive fluids at high medium temperatures

- Long product life cycle – robust sensor for challenging environments
- High-performance wetted materials – corrosion-resistant PTFE or PFA liners available
- Minimum costs for maintenance and repair – designed without moving parts
- Energy-saving flow measurement – no pressure loss
- System integration compatibility – automatic restoration of the original firmware in service cases
- Increased plant accessibility – flexible, quick commissioning and servicing due to web server and WLAN

Available Added Values with Promag P 300



Proline 300

Proline 300

Transmitter

The compact transmitter offers high flexibility in terms of operation and system integration: access from one side, remote display and improved connectivity options. Heartbeat Technology enables compliance and process safety at all times.

Additional information



Promag P

Promag P

Sensor

Promag P is dedicated to chemical and process applications with corrosive liquids and highest fluid temperatures.

Approvals

Hazardous area approvals

ATEX, IECEx, CSA, NEPSI, INMETRO, KC

Functional approvals and test certificates

- Drinking water approvals
- CRN
- PED Cat. II/III
- 3.1 material certificate



Promag W 300

Promag W 300

EN ISO 12944 corrosion-protected electromagnetic sensor with a compact, easily accessible transmitter

- Long product life cycle – robust sensor for challenging environments
- Reliable long-term operation – completely welded sensor in IP68 (Type 6P enclosure)
- Flexible engineering – space-saving due to sensor option without inlet and outlet runs
- Energy-saving flow measurement – no pressure loss
- System integration compatibility – automatic restoration of the original firmware in service cases
- Increased plant accessibility – flexible, quick commissioning and servicing due to web server and WLAN

Available Added Values with Promag W 300



Proline 300

Proline 300

Transmitter

The compact transmitter offers high flexibility in terms of operation and system integration: access from one side, remote display and improved connectivity options. Heartbeat Technology enables compliance and process safety at all times.

Additional information



Promag W

Promag W

Sensor

Promag W is the robust sensor for all water applications in the mining, minerals and metals industry. Its rugged design features certified corrosion protection and various liner options.

Approvals

Custody transfer approvals

OIML Class 1 / OIML Class 2, MI-001

Promag W is available with lap-joint flanges and welded flanges as well as with certified corrosion protection (EN ISO 12944).



Industry needs [Measurement control](#)



Keep your measurement under perfect control

Extreme temperatures, potentially hazardous fluids and high energy consumption are common in the industry. They demand both great diligence and strict environmental regulations. Safety and sustainability have to be assured by infallible process monitoring, verification and measurement.

Our solution Heartbeat Technology – the outstanding integrated diagnostics, verification and monitoring concept – allows comprehensive,

reliable process monitoring and predictive maintenance. It boosts your competitiveness by maximizing your plant performance and minimizing unplanned operating failures.

Additional information

Industry needs

Environmental responsibility

Environmental responsibility under harsh conditions

The production of minerals and metals requires chemicals and large capacities of water and energy. Measuring devices have to withstand harsh environments and aggressive processes while emission regulations for air and water are to be met.

Our solution Our robust, tried and tested, reliable measuring devices with industry-specific approvals provide accurate measurement and diagnostics for resource-friendly process optimization. Thus, you

can reduce your environmental impact in compliance with legal regulations, be it water, air or chemicals, while simultaneously increasing your plant efficiency.

Additional information



Proline simply clever

Endress+Hauser 

Proline in
Power & Energy



t-mass F 300

t-mass F 300

High-performing, intelligent inline flowmeter with a compact transmitter

Versatile scope of application for both process and utility gases

- Application-specific process control – high measuring accuracy and freely definable gas mixtures
- Process monitoring – alerts to common process disturbances, e.g., droplets or pulsating flow
- Cost-savings – negligible pressure loss, low maintenance due to drift-free, easily removable sensor
- Full access to process and diagnostic information – numerous, freely combinable I/Os and fieldbuses
- Device verification without removal or process interruption – integrated Heartbeat Technology
- Optimized safety – compliant with industry requirements, e.g., SIL, hazardous area, pressure equipment standards, etc.

Available Added Values with t-mass F 300



Proline 300

Proline 300

Transmitter

The compact transmitter offers high flexibility in terms of operation and system integration: access from one side, remote display and improved connectivity options. Heartbeat Technology enables compliance and process safety at all times.

Additional information



t-mass F

t-mass F

Sensor

t-mass F is made of a casted body with welded forged flanges, a patented robust, drift-free and removable sensor, available in stainless steel or Alloy C22, and uses no synthetic seals. In line sizes up to DN 100 (4").

- Optionally available with integrated flow conditioner reducing inlet runs down to $0 \times DN$.
- Optionally available with bidirectional flow measurement or reverse flow detection.
- Insertion version available for larger line sizes.

Approvals

Hazardous area approvals

ATEX, IECEx, CSA/US, EAC, JPN, INMETRO, NEPSI

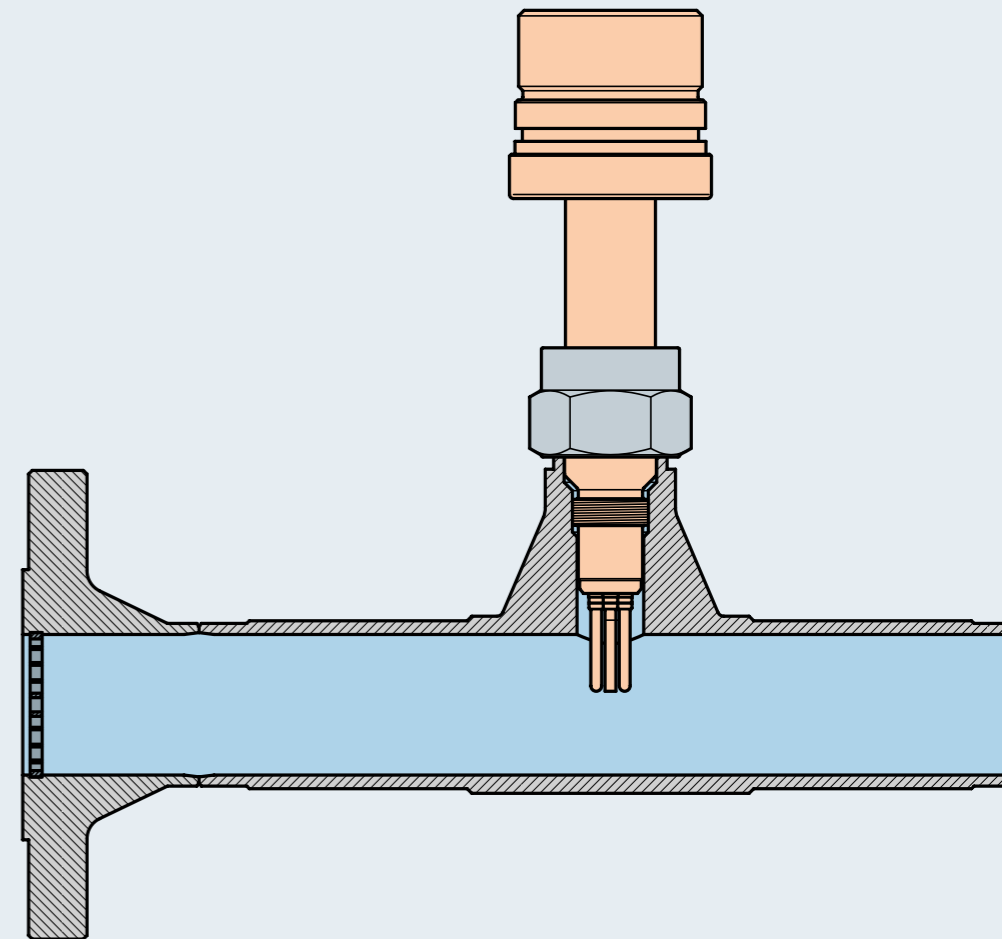

Promag W 400

Promag W 400

Cost-effective standard magmeter with integrated web server

Optimal solution for the accurate measurement of raw and cooling water

- Fewer downtimes – first-class, reliable flowmeter
- Rugged design for demanding environments – corrosion-resistant sensor housing
- Highest accuracy without pressure drop and without inlet runs (0 x DN full-bore option) – compact sensor
- Integrated conductivity trend to increase availability (option)
- Safe operation – no need to open the device due to display with touch control and background lighting
- Increased productivity – automatic data logging enables fast exchange of spare parts (HistoROM)
- Easy operation via WLAN

Available Added Values with Promag W 400

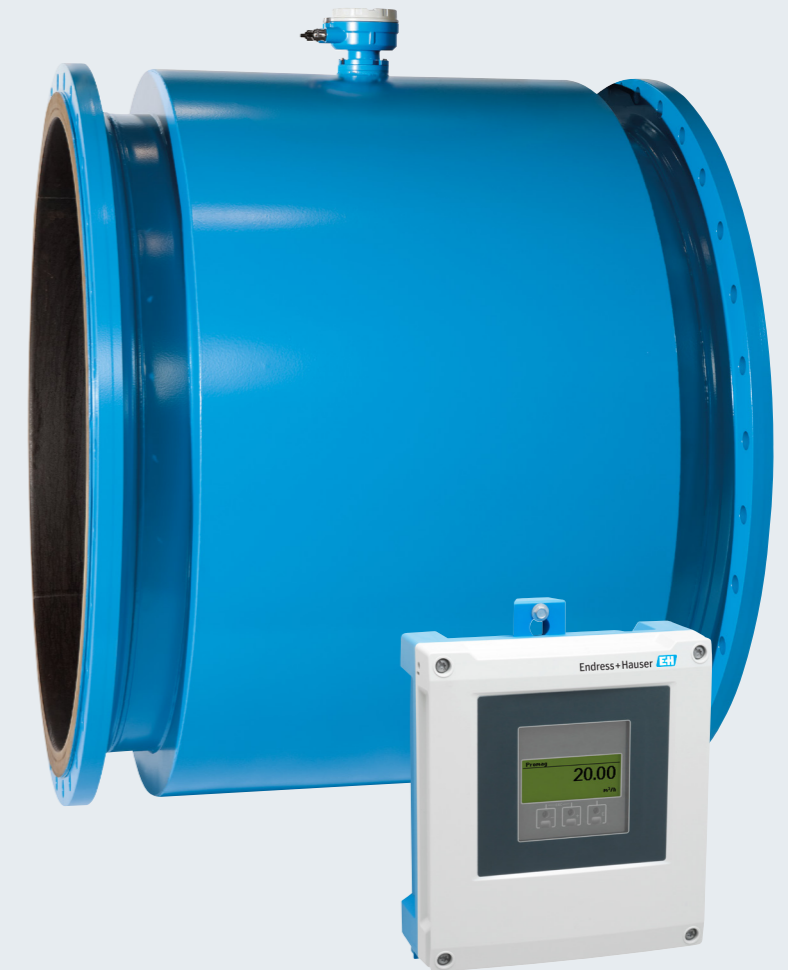

Proline 400

Proline 400

Transmitter

Proline 400 with its broad functionality is the cost- and time-saving transmitter ideal for industrial water applications in Power & Energy. In addition, Heartbeat Technology enables compliance and process safety at all times.

Additional information



Promag W

Promag W

Sensor

Promag W combines accuracy and reliability for industrial water applications in Power & Energy. Its wide range of nominal diameters, liners and process connections allows diverse application possibilities.

Promag W is available with lap-joint flanges and welded flanges as well as with certified corrosion protection (EN ISO 12944). Promag W sensors don't require any inlet/outlet runs thanks to the innovative 0 x DN full-bore option. An integrated conductivity measurement can be ordered on request.

Approvals

Custody transfer approvals

OIML Class 1 / OIML Class 2, MI-001



Proline Added Values

Simply clever



Tap to navigate

Proline – simply clever

Proline – simply clever

Reliable flow measuring technology without compromises

Proline exceeds all industry-relevant regulations with regard to process safety (SIL), approvals, custody transfer, product quality, and system availability

Proline guarantees significantly lower operating costs over the entire life cycle of field measuring devices

Proline is ready for digital networking and its opportunities in process automation through the “Internet of Things”

Proline makes it easier to fully access device and configuration data using all interfaces, and therefore increases system availability

Proline offers more than just flow measurement and, with Heartbeat Technology, also gives an insight into the process



Operation concept (HMI)



Operation concept (HMI)

Simplicity through uniformity

- Reduced complexity of operation – time-saving, standardized operating concept with uniform user interfaces, menu structures and parameter names
- Quick and safe commissioning – faultless operation due to guided parameterization for applications and brief explanations of the parameter functions
- Optimum usability – operator-oriented menu structure for user-specific tasks and multi-language support for worldwide use



Seamless system integration

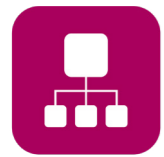

Seamless system integration

Device integration independent of fieldbus technology

- Direct and transparent integration of devices – flowmeters available with all state-of-the-art fieldbuses
- Perfect interaction between device and host – risk-free integration through extended host testing and certification
- Simple device replacement without expert know-how: guaranteed compatibility between devices and process control systems at all times

Additional information

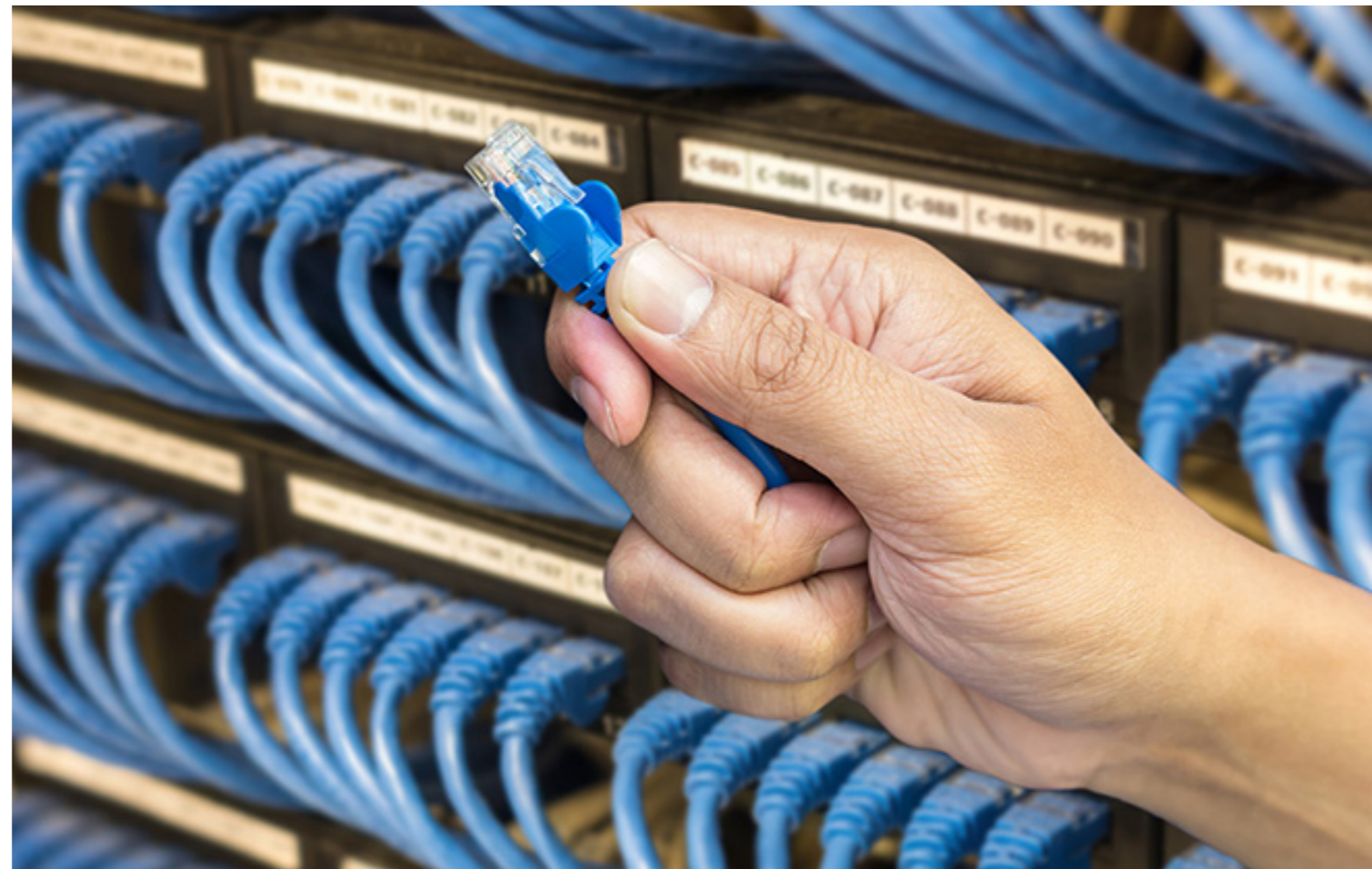

Web server



Web server

Device operation and data access made easy

- No wasting of time due to complex systems – no special equipment, software or additional interfaces required
- Increased plant accessibility – time-saving local operation and comprehensive access to device, diagnostic and process information
- No unnecessary plant downtime – fast data up-/download during maintenance or service, e.g., for data storage

Additional information





Data storage concept (HistoROM)

Simply unforgettable

- Maximum plant safety – automatic storage of all device and configuration data
- Quick, easy and safe exchange of components without need for parameterization or special user know-how – automatic restoration of data and settings
- Optimized operation and maintenance – safe monitoring of data series and quick failure analysis by integrated event logbook and data logger

Additional information

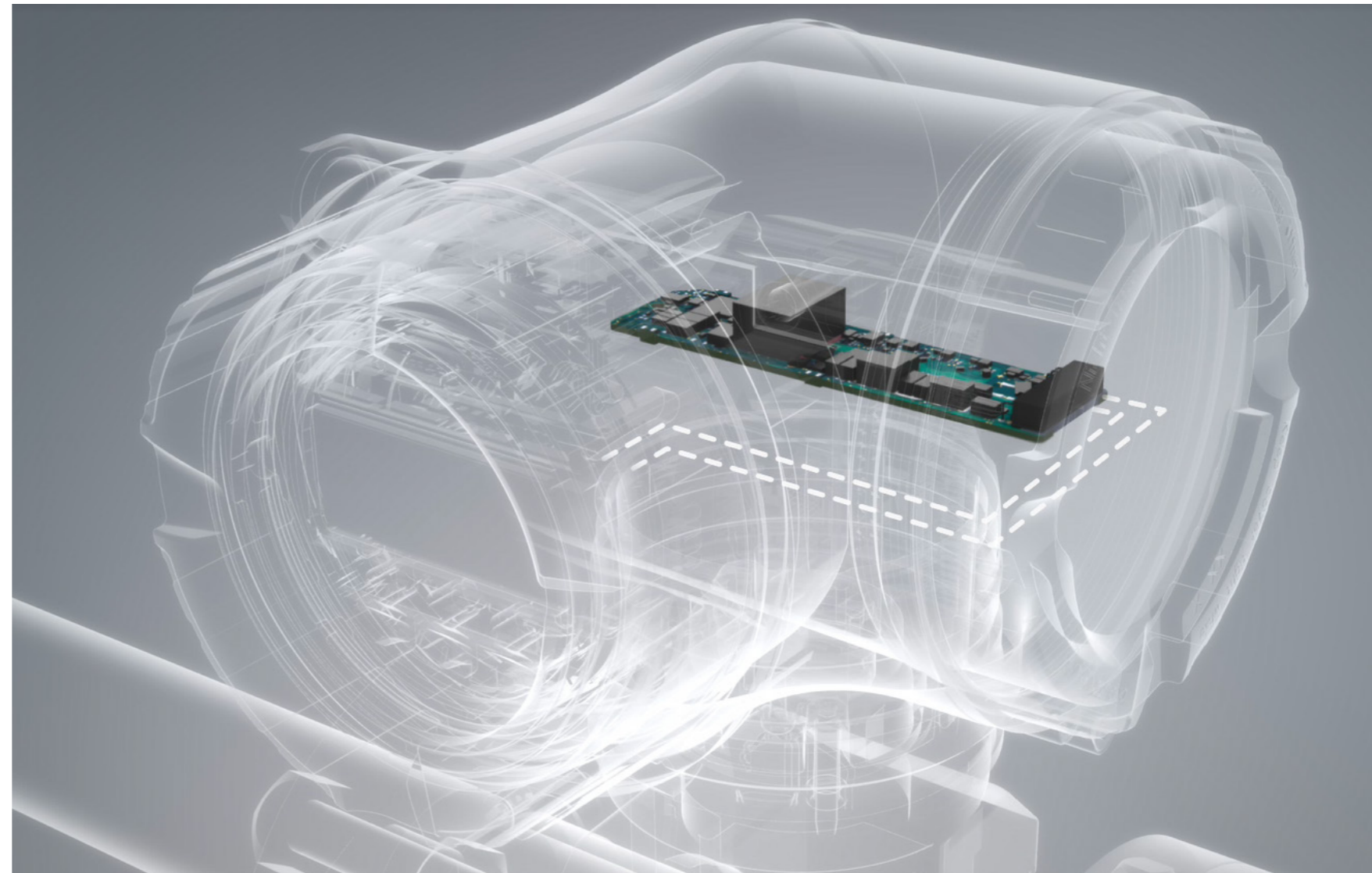



Heartbeat Technology

Takes the pulse of your measurement and provides in-depth insights

- Increase reliability and confidence in your measurements with **Heartbeat Diagnostics**
- Be efficient in your testing efforts while enabling compliance thanks to **Heartbeat Verification**
- Obtain insights to optimize your processes and predict maintenance needs through **Heartbeat Monitoring**

Additional information



Your benefits close-up

Proline 300/500 – for permanently increased safety, quality and availability in your plant

Safe all-around – you can count on that

The current Proline generation is based on decades of experience in safety-related applications

High-quality – for smooth processes

Proline 300/500 has been developed for the highest levels of process and product quality coupled with low maintenance effort and low total cost of ownership thanks to Heartbeat Technology

Available at any time – process and device information

Proline 300/500, with its numerous fieldbus interfaces, makes it possible to access all device and process data directly, thus ensuring optimal operation



Netilion – the multi-brand ecosystem

Improved efficiency – empowered to drive innovation

- For maximum plant transparency
- Compliant to internationally recognized standards of cloud-platform security
- Decentralized processes monitored efficiently through comprehensive visualization of essential process variables. Low operating costs through fast reaction in case of failure.
- Legal compliance thanks to automation of measurement and to integrated reporting systems
- Data access independent of time and place thanks to web-based visualization of networks

Additional information

