

Operating Instructions

Deltabar PMD75B

Differential pressure measurement
HART

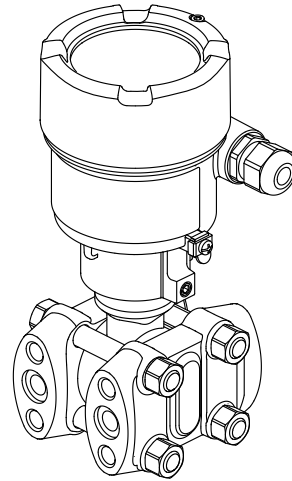



A0023555

- Make sure the document is stored in a safe place such that it is always available when working on or with the device
- Avoid danger to individuals or the facility: read the "Basic safety instructions" section carefully, as well as all other safety instructions in the document that are specific to working procedures

The manufacturer reserves the right to modify technical data without prior notice. The Endress+Hauser sales organization will supply you with current information and updates to these instructions.

Table of contents

1	About this document	5	8	System integration	35
1.1	Document function	5	8.1	Overview of device description files	35
1.2	Symbols	5	8.2	Measured variables via HART protocol	35
1.3	List of abbreviations	7	9	Commissioning	37
1.4	Turn down calculation	7	9.1	Preparatory steps	37
1.5	Documentation	8	9.2	Function check	37
1.6	Registered trademarks	8	9.3	Switching on the measuring device	38
2	Basic safety instructions	9	9.4	Establishing a connection via FieldCare and DeviceCare	38
2.1	Requirements for the personnel	9	9.5	Configuring the device address via software ..	38
2.2	Designated use	9	9.6	Setting the operating language	39
2.3	Workplace safety	9	9.7	Configuring the measuring device	40
2.4	Operational safety	9	9.8	"Simulation" submenu	51
2.5	Product safety	10	9.9	Protecting settings from unauthorized access	51
2.6	Functional Safety SIL (optional)	10	10	Operation	53
2.7	IT security	10	10.1	Reading the device locking status	53
2.8	Device-specific IT security	10	10.2	Reading measured values	53
3	Product description	11	10.3	Adapting the measuring device to the process conditions	53
3.1	Product design	11	11	Diagnostic and troubleshooting	55
4	Incoming acceptance and product identification	12	11.1	General troubleshooting	55
4.1	Incoming acceptance	12	11.2	Diagnostic information on local display	59
4.2	Product identification	12	11.3	Diagnostic event in the operating tool	61
4.3	Storage and transport	13	11.4	Adapting the diagnostic information	61
5	Installation	14	11.5	Queued diagnostic messages	61
5.1	Installation conditions	14	11.6	Diagnostic list	61
5.2	Mounting the measuring device	16	11.7	Event logbook	64
5.3	Post-installation check	24	11.8	Resetting the measuring device	65
6	Electrical connection	25	11.9	Device information	65
6.1	Connection conditions	25	11.10	Firmware history	66
6.2	Connecting the measuring device	25	12	Maintenance	67
6.3	Ensuring the degree of protection	29	12.1	Maintenance tasks	67
6.4	Post-connection check	30	13	Repair	68
7	Operation options	31	13.1	General notes	68
7.1	Overview of operation options	31	13.2	Spare parts	68
7.2	Operating keys and DIP switches on the electronic insert	31	13.3	Replacement	68
7.3	Structure and function of the operating menu	31	13.4	Return	70
7.4	Access to the operating menu via the local display	32	13.5	Disposal	70
7.5	Access to the operating menu via the operating tool	34	14	Accessories	71
7.6	HistoROM	34	14.1	Device-specific accessories	71
			14.2	Device Viewer	71
			15	Technical data	72
			15.1	Output	72

15.2 Environment	75
15.3 Process	78
Index	82

1 About this document

1.1 Document function

These Operating Instructions contain all the information that is required in various phases of the life cycle of the device: from product identification, incoming acceptance and storage, to mounting, connection, operation and commissioning through to troubleshooting, maintenance and disposal.

1.2 Symbols

1.2.1 Safety symbols

 DANGER

This symbol alerts you to a dangerous situation. Failure to avoid this situation will result in serious or fatal injury.

 WARNING

This symbol alerts you to a dangerous situation. Failure to avoid this situation can result in serious or fatal injury.

 CAUTION

This symbol alerts you to a dangerous situation. Failure to avoid this situation can result in minor or medium injury.

NOTICE

This symbol contains information on procedures and other facts which do not result in personal injury.

1.2.2 Electrical symbols

Ground connection: 

Terminal for connection to the grounding system.

1.2.3 Symbols for certain types of information

Permitted: 

Procedures, processes or actions that are permitted.

Forbidden: 

Procedures, processes or actions that are forbidden.

Additional information: 

Reference to documentation: 

Reference to page: 

Series of steps: [1](#), [2](#), [3](#).

Result of an individual step: 



1.2.4 Symbols in graphics

Item numbers: 1, 2, 3 ...

Series of steps: [1](#), [2](#), [3](#).

Views: A, B, C, ...

1.2.5 Symbols on the device

Safety instructions:  → 

Observe the safety instructions contained in the associated Operating Instructions.

1.3 List of abbreviations

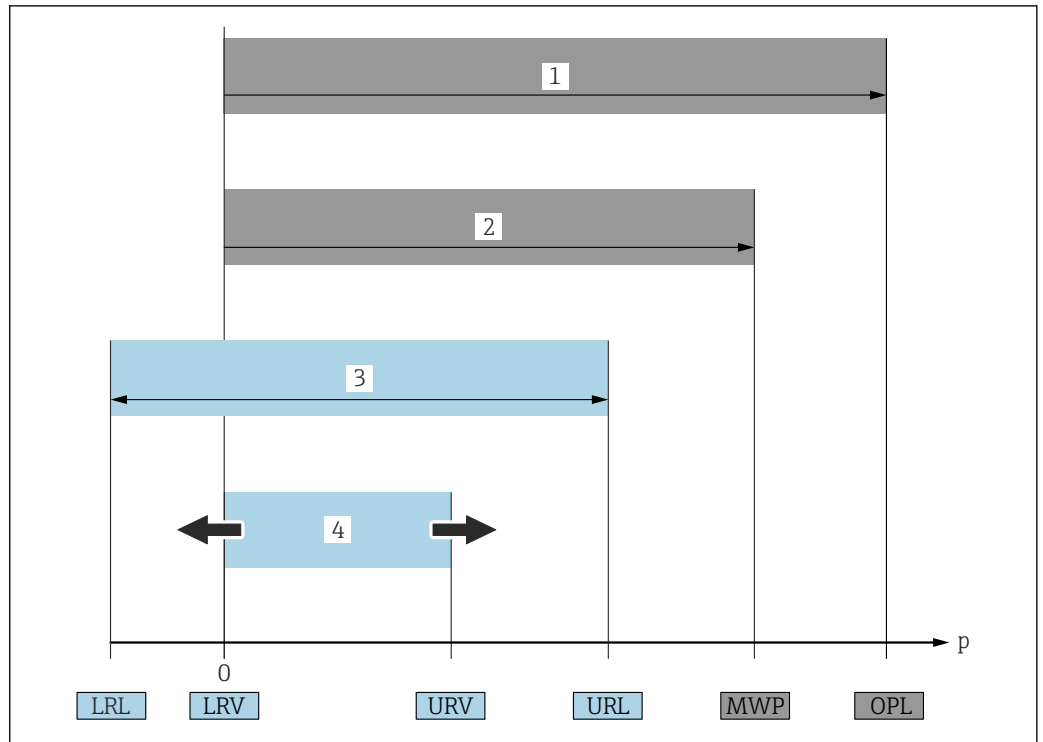

A0029505

- 1 OPL: The OPL (over pressure limit = sensor overload limit) for the measuring device depends on the lowest-rated element, with regard to pressure, of the selected components, i.e. the process connection has to be taken into consideration in addition to the measuring cell. Pay attention to the pressure/temperature dependency.
 - 2 MWP: The MWP (maximum working pressure) for the sensors depends on the lowest-rated element, with regard to pressure, of the selected components, i.e. the process connection has to be taken into consideration in addition to the measuring cell. Pay attention to the pressure/temperature dependency. The MWP may be applied at the device for an unlimited period of time. The MWP can be found on the nameplate.
 - 3 The maximum sensor measuring range corresponds to the span between the LRL and URL. This sensor measuring range is equivalent to the maximum calibratable/adjustable span.
 - 4 The calibrated/adjusted span corresponds to the span between the LRV and URV. Factory setting: 0 to URL. Other calibrated spans can be ordered as customized spans.
- p Pressure
 LRL Lower range limit
 URL Upper range limit
 LRV Lower range value
 URV Upper range value
 TD Turn down. Example - see the following section.

1.4 Turn down calculation

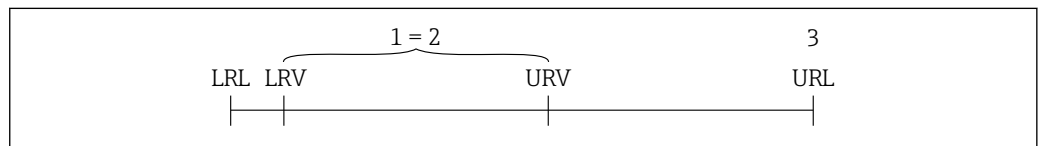

A0029545

- 1 Calibrated/adjusted span
- 2 Zero point-based span
- 3 Upper range limit (URL)

Example:

- Sensor: 16 bar (240 psi)
- Upper range limit (URL) = 16 bar (240 psi)
- Calibrated/adjusted span: 0 to 8 bar (0 to 120 psi)
- Lower range value (LRV) = 0 bar (0 psi)
- Upper range value (URV) = 8 bar (120 psi)

$$\text{TD} = \frac{\text{URL}}{|\text{URV} - \text{LRV}|}$$

In this example, the TD is 2:1. This span is based on the zero point.

1.5 Documentation

All available documents can be downloaded using:

- the serial number of the device (see cover page for description) or
- the data matrix code of the device (see cover page for description) or
- the "Downloads" area of the website www.endress.com

1.5.1 Supplementary device-dependent documentation

Additional documents are supplied depending on the device version ordered: Always comply strictly with the instructions in the supplementary documentation. The supplementary documentation is an integral part of the device documentation.

1.6 Registered trademarks

HART®

Registered trademark of the FieldComm Group, Austin, Texas, USA

Bluetooth®

The Bluetooth® wordmark and logos are registered trademarks of Bluetooth SIG, Inc. and any use of these trademarks by Endress+Hauser is licensed. Other trademarks and trade names are those of their respective owners.

Apple®

Apple, the Apple logo, iPhone, and iPod touch are trademarks of Apple Inc., registered in the U.S. and other countries. App Store is a service mark of Apple Inc.

Android®

Android, Google Play and the Google Play logo are trademarks of Google Inc.

2 Basic safety instructions

2.1 Requirements for the personnel

The personnel for installation, commissioning, diagnostics and maintenance must fulfill the following requirements:

- ▶ Trained, qualified specialists must have a relevant qualification for this specific function and task
- ▶ Are authorized by the plant owner/operator
- ▶ Are familiar with federal/national regulations
- ▶ Before beginning work, the specialist staff must have read and understood the instructions in the Operating Instructions and supplementary documentation as well as in the certificates (depending on the application)
- ▶ Follow instructions and comply with conditions

The operating personnel must fulfill the following requirements:

- ▶ Being instructed and authorized according to the requirements of the task by the facility's owner-operator
- ▶ Following the instructions in these Operating Instructions

2.2 Designated use

The Deltabar is a differential pressure transmitter for measuring pressure, flow, level and differential pressure.

2.2.1 Incorrect use

The manufacturer is not liable for damage caused by improper or non-designated use.

Verification for borderline cases:

- ▶ For special fluids and fluids for cleaning, Endress+Hauser is glad to provide assistance in verifying the corrosion resistance of fluid-wetted materials, but does not accept any warranty or liability.

2.3 Workplace safety

When working on and with the device:

- ▶ Wear the required personal protective equipment according to federal/national regulations.
- ▶ Switch off the supply voltage before connecting the device.

2.4 Operational safety

Risk of injury!

- ▶ Operate the device only if it is in proper technical condition, free from errors and faults.
- ▶ The operator is responsible for the interference-free operation of the device.

Modifications to the device

Unauthorized modifications to the device are not permitted and can lead to unforeseeable dangers:

- ▶ If, despite this, modifications are required, consult with Endress+Hauser.

Repair

To ensure continued operational safety and reliability:

- ▶ Carry out repairs on the device only if they are expressly permitted.
- ▶ Observe federal/national regulations pertaining to the repair of an electrical device.

- ▶ Use original spare parts and accessories from Endress+Hauser only.

Hazardous area

To eliminate the risk of danger to persons or the facility when the device is used in the approval-related area (e.g. explosion protection, pressure equipment safety):

- ▶ Check the nameplate to verify if the device ordered can be put to its intended use in the approval-related area.
- ▶ Observe the specifications in the separate supplementary documentation that is an integral part of these Instructions.

2.5 Product safety

This measuring device is designed in accordance with good engineering practice to meet state-of-the-art safety requirements, has been tested, and left the factory in a condition in which it is safe to operate.

It meets general safety standards and legal requirements. It also complies with the EC directives listed in the device-specific EC Declaration of Conformity. Endress+Hauser confirms this by affixing the CE mark to the device.

2.6 Functional Safety SIL (optional)

The Functional Safety Manual must be strictly observed for devices that are used in functional safety applications.

2.7 IT security

Endress+Hauser can only provide a warranty if the device is installed and used as described in the Operating Instructions. The device is equipped with security mechanisms to protect it against any inadvertent changes to the device settings. IT security measures in line with operators' security standards and designed to provide additional protection for the device and device data transfer must be implemented by the operators themselves.

2.8 Device-specific IT security

The device offers specific functions to support protective measures by the operator. These functions can be configured by the user and guarantee greater in-operation safety if used correctly. An overview of the most important functions is provided in the following section:

- Write protection via hardware write protection switch
- Access code (applies for operation via display, Bluetooth or FieldCare, DeviceCare, ASM, PDM)

3 Product description

3.1 Product design

3.1.1 Measuring cell for differential pressure with metal process isolating diaphragm

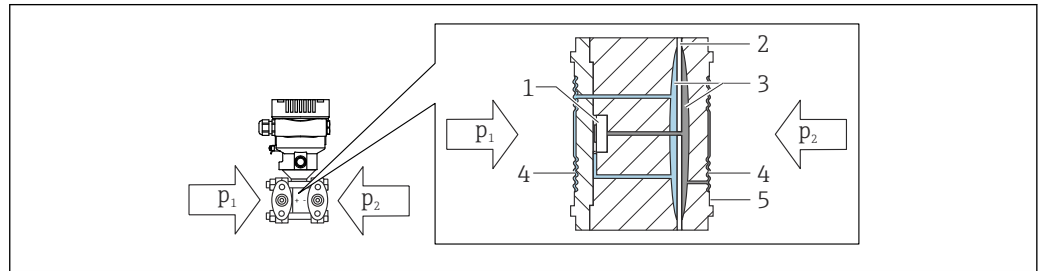

A0043083

- 1 Measuring element
- 2 Middle diaphragm
- 3 Fill fluid
- 4 Process isolating diaphragm
- 5 Seal
- p_1 Pressure 1
- p_2 Pressure 2

The process isolating diaphragms are deflected on both sides by the acting pressures. A fill fluid transfers the pressure to a side of the measuring element where a resistance bridge is located (semiconductor technology). The change in the bridge output voltage, which depends on the differential pressure, is measured and processed further.

3.1.2 Flow measurement

Flow measurement with Deltabar and differential pressure sensor:

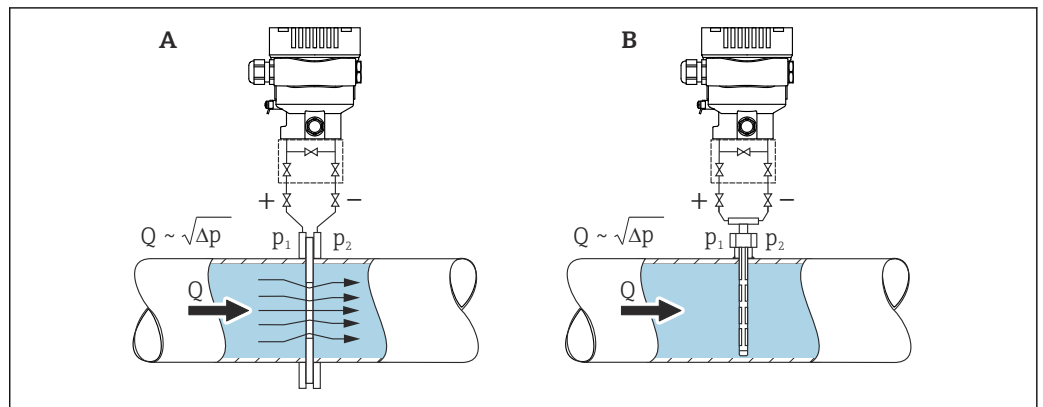

A0038340

- A Orifice plate
- B Pitot tube
- Q Flow
- Δp Differential pressure, $\Delta p = p_1 - p_2$

Advantages:

- A customized unit can be specified
- Measured value suppression can be set in the lower measuring range with the **Low flow cut off** parameter.

4 Incoming acceptance and product identification

4.1 Incoming acceptance

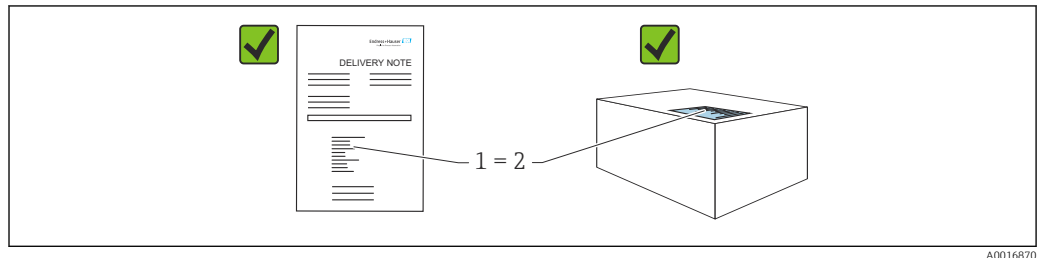

- Is the order code on the delivery note (1) identical to the order code on the product sticker (2)?
- Are the goods undamaged?
- Do the data on the nameplate correspond to the order specifications and the delivery note?
- Is the documentation provided?
- If required (see nameplate): are the Safety Instructions (XA) provided?

i If you can answer "no" to any of these questions, please contact Endress+Hauser.

4.1.1 Scope of delivery

The scope of delivery comprises:

- Measuring device
- Optional accessories

Documentation supplied:

- Brief Operating Instructions
- Final inspection report
- Additional safety instructions for devices with approvals (e.g. ATEX, IECEx, NEPSI, etc.)
- Optional: factory calibration form, test certificates

i The Operating Instructions are available on the Internet at:

www.endress.com → Download

4.2 Product identification

The following options are available for the identification of the measuring device:

- Nameplate specifications
- Order code with breakdown of the device features on the delivery note
- Enter the serial numbers from the nameplates in *Device Viewer* (www.endress.com/deviceviewer): all the information about the measuring device is displayed.

4.2.1 Manufacturer address

Endress+Hauser SE+Co. KG
Hauptstraße 1
79689 Maulburg, Germany

Place of manufacture: See nameplate.

4.2.2 Nameplates

Different nameplates are used depending on the device version.

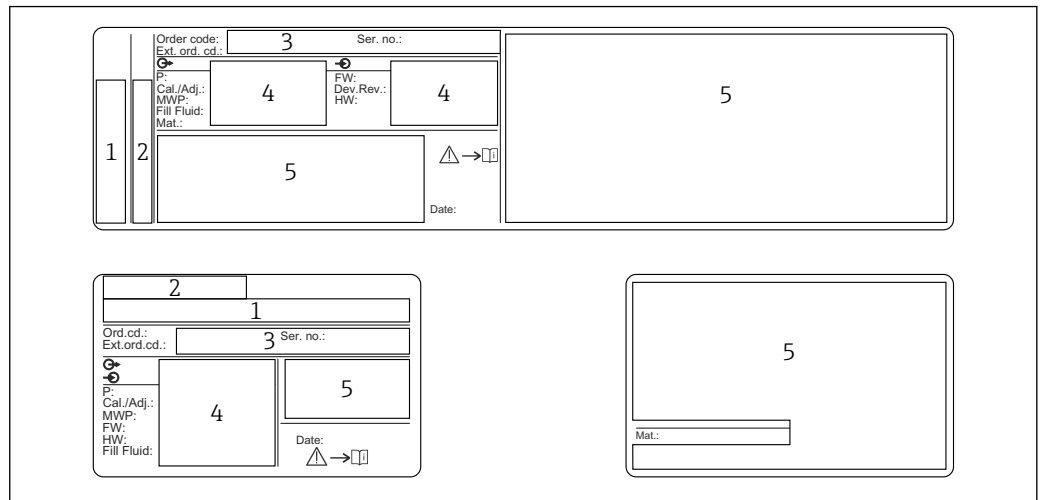

A0038163

- 1 Manufacturer name and device name
- 2 Address of the certificate holder and country of manufacture
- 3 Order code and serial number
- 4 Technical data
- 5 Approval-specific information

4.3 Storage and transport

4.3.1 Storage conditions

- Use the original packaging
- Store the measuring device in clean and dry conditions and protect from damage caused by shocks

Storage temperature range

See Technical Information.

4.3.2 Transporting the product to the measuring point

⚠ WARNING

Incorrect transport!

Housing and membrane may become damaged, and there is a risk of injury!

- ▶ Transport the measuring device to the measuring point in the original packaging.

5 Installation

NOTICE

The measuring device may be damaged if handled incorrectly!

- ▶ Disassembly of the screws with item number (1) is not permissible under any circumstances and will result in loss of warranty.

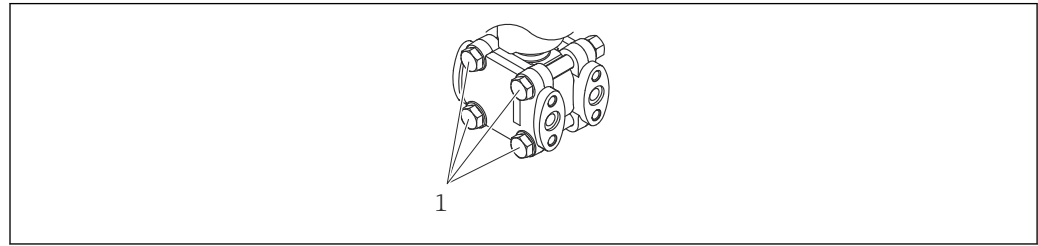

5.1 Installation conditions

5.1.1 General instructions

- Do not clean or touch process membrane with hard and/or pointed objects
- Do not remove process membrane protection until shortly before installation

Always firmly tighten the housing cover and the cable entries.

1. Counter-tighten the cable entries.
2. Tighten the coupling nut.

5.1.2 Installation instructions

- To ensure optimum readability of the onsite display, align the housing and onsite display
- Endress+Hauser offers a mounting bracket for installing the measuring device on pipes or walls
- When measuring in media containing solids (e.g. dirty liquids), installing separators and drain valves is useful for capturing and removing sediment
- Using a valve manifold allows for easy commissioning, installation and maintenance without interrupting the process
- When mounting the device, establishing the electrical connection and during operation: prevent the penetration of moisture into the housing
- Point the cable and connector downwards as much as possible to prevent the penetration of moisture (e.g. rain water or condensation)

5.1.3 Installing pressure piping

- For recommendations for routing pressure piping, refer to DIN 19210 "Differential pressure piping for flow measurement devices" or the corresponding national or international standards
- When routing the pressure piping outdoors, ensure sufficient anti-freeze protection, e.g. by using pipe heat tracing
- Install the pressure piping with a monotonic gradient of at least 10%

5.1.4 Orientation

The installation depends on how the impulse lines are connected.

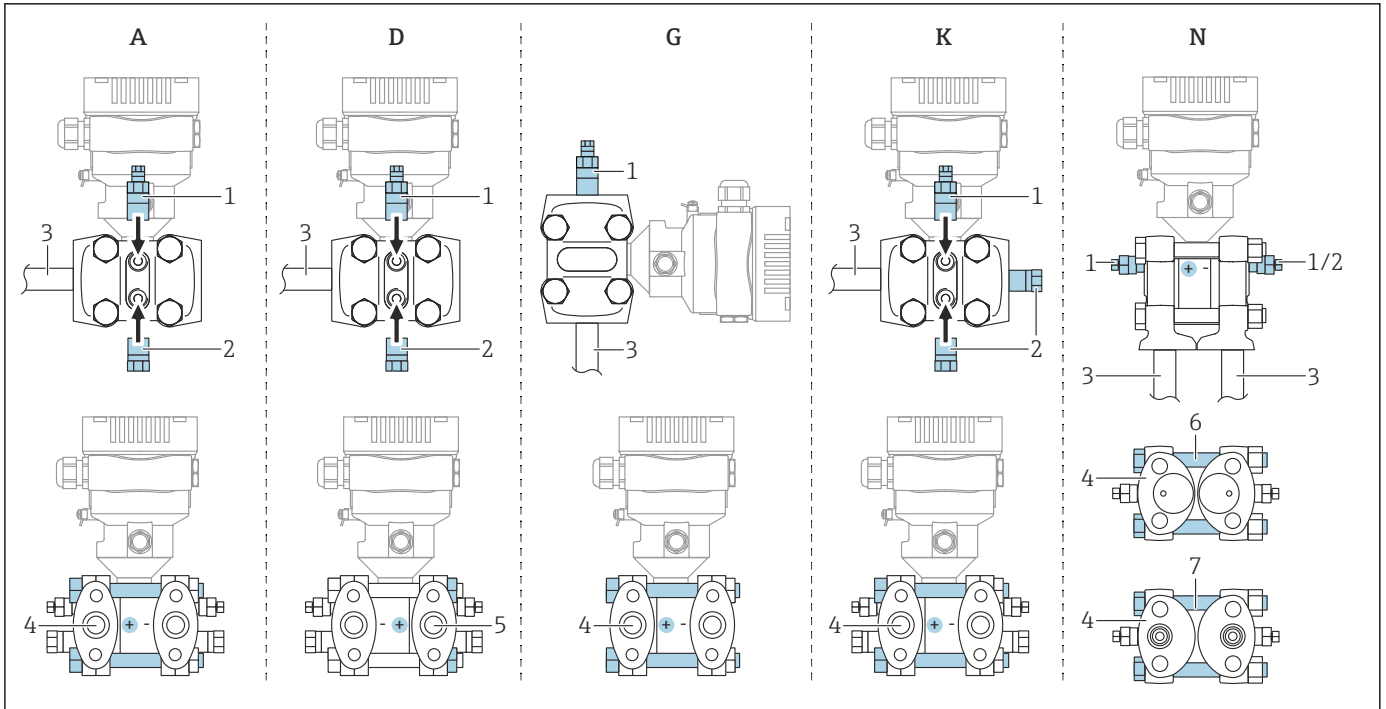

A0038688

1 A, D, G, K, N: order options

- A Horizontal impulse line, left side HP (screw head side), with side vent. Thread on one side and side thread for horizontal impulse line.
- D Horizontal impulse line, right side HP (nut side), with side vent. Thread on one side and side thread for horizontal impulse line.
- G Vertical impulse line, left or right side HP (screw head side), with vent. Thread on each side for vertical impulse line.
- K Universal side flange, left or right side HP (screw head side), with vent. Thread on each side and side thread for universal mounting.
- N Bottom process connection, left side HP (screw head side), vent. Thread on each side and side thread for mounting on existing manifolds.
- 1 Vent valve
- 2 Sealing plug
- 3 Impulse line
- 4 High-pressure (HP) side (screw head side)
- 5 High-pressure (HP) side (nut side)
- 6 Coplanar compatible, view from below
- 7 IEC upright, view from below

5.2 Mounting the measuring device

5.2.1 Flow measurement

Flow measurement in gases

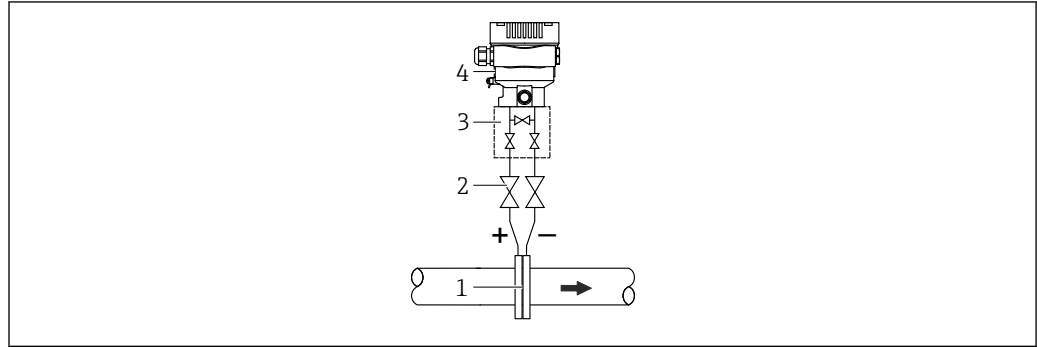

A0038211

- 1 Orifice plate or pitot tube
- 2 Shutoff valves
- 3 Three-valve manifold
- 4 Measuring device

Mount the measuring device above the measuring point so that condensate can flow into the process piping.

Flow measurement in vapors

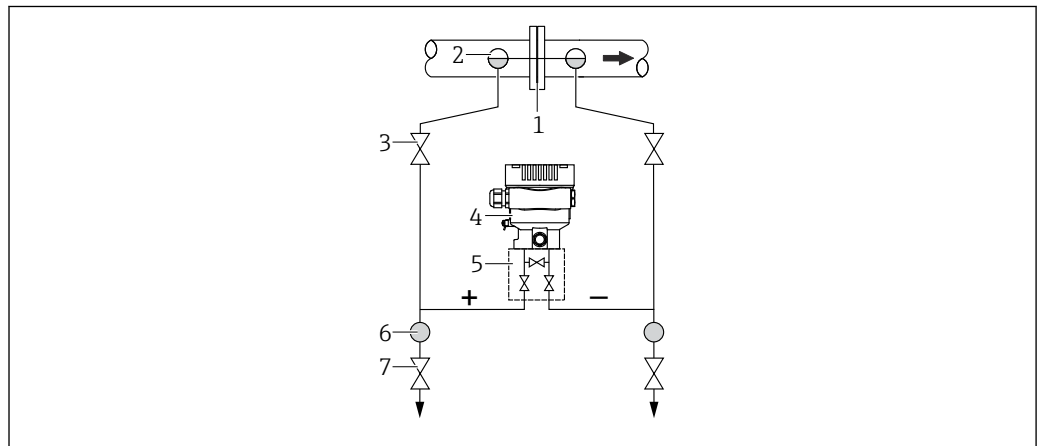

A0038212

- 1 Orifice plate or pitot tube
- 2 Condensate traps
- 3 Shutoff valves
- 4 Measuring device
- 5 Three-valve manifold
- 6 Separator
- 7 Drain valves

- Mount the measuring device below the measuring point
- Mount the condensate traps at the same level as the tapping points and at the same distance to the measuring device
- Prior to commissioning, fill the impulse lines to the height of the condensate traps

Flow measurement in liquids

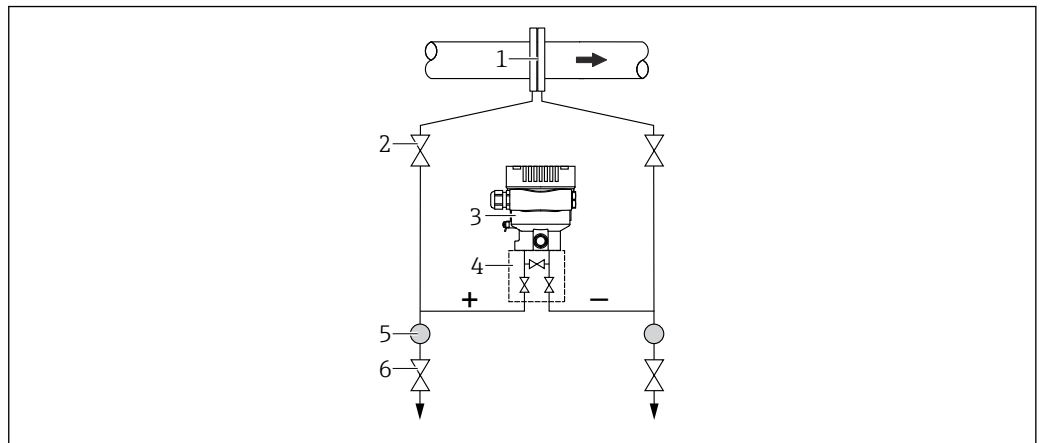

A0038213

- 1 Orifice plate or pitot tube
- 2 Shutoff valves
- 3 Measuring device
- 4 Three-valve manifold
- 5 Separator
- 6 Drain valves

- Mount the measuring device below the measuring point so that the pulse lines are always filled with liquid and gas bubbles can run back into the process piping
- When measuring in media with solid parts, such as dirty liquids, installing separators and drain valves is useful for capturing and removing sediment

5.2.2 Level measurement

Level measurement in open vessels

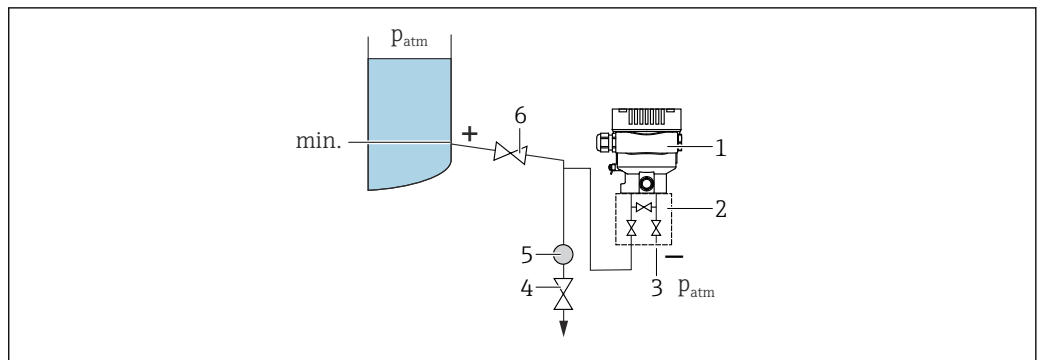

A0038215

- 1 Measuring device
- 2 Three-valve manifold
- 3 The low-pressure side is open to atmospheric pressure
- 4 Drain valve
- 5 Separator
- 6 Shutoff valve

- Mount the measuring device below the lower measuring connection so that the impulse lines are always filled with liquid
- The low-pressure side is open to atmospheric pressure
- When measuring in media with solid parts, such as dirty liquids, installing separators and drain valves is useful for capturing and removing sediment

Level measurement in a closed vessel

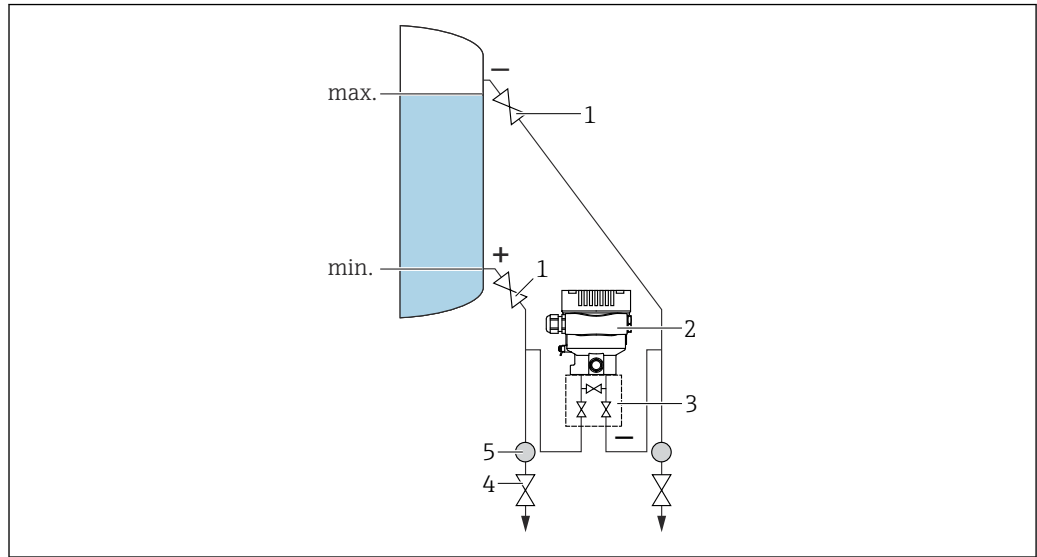

A0038217

- 1 Shutoff valves
- 2 Measuring device
- 3 Three-valve manifold
- 4 Drain valves
- 5 Separator

- Mount the measuring device below the lower measuring connection so that the impulse lines are always filled with liquid
- Always connect the low-pressure side above the maximum level
- When measuring in media with solid parts, such as dirty liquids, installing separators and drain valves is useful for capturing and removing sediment

Level measurement in a closed vessel with superimposed vapor

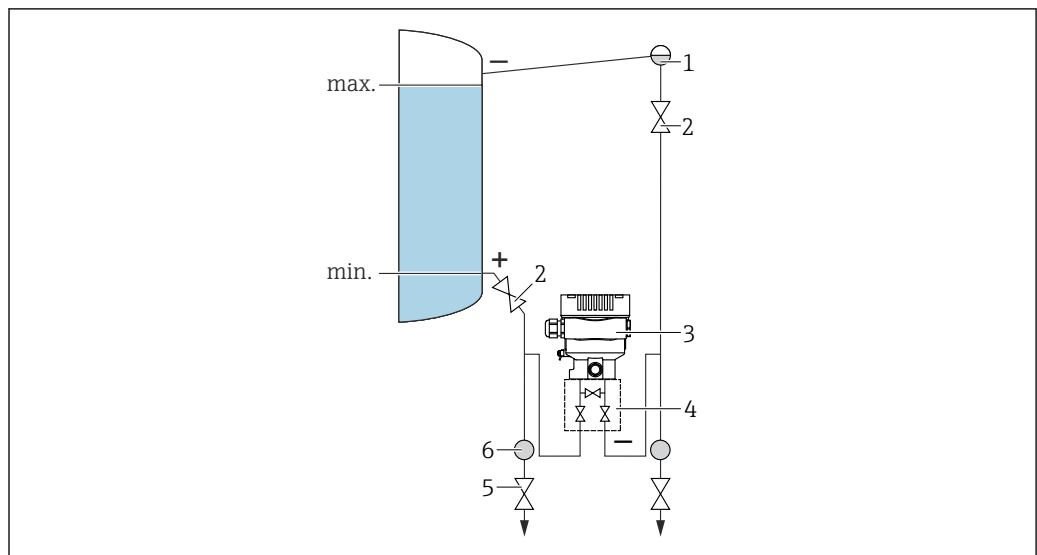

A0038216

- 1 Condensate trap
- 2 Shutoff valves
- 3 Measuring device
- 4 Three-valve manifold
- 5 Drain valves
- 6 Separator

- Mount the measuring device below the lower measuring connection so that the impulse lines are always filled with liquid
- Always connect the low-pressure side above the maximum level
- The condensate trap ensures constant pressure on the low-pressure side
- When measuring in media with solid parts, such as dirty liquids, installing separators and drain valves is useful for capturing and removing sediment

5.2.3 Pressure measurement

Pressure measurement with 160 bar (2 400 psi) and 250 bar (3 750 psi) measuring cell

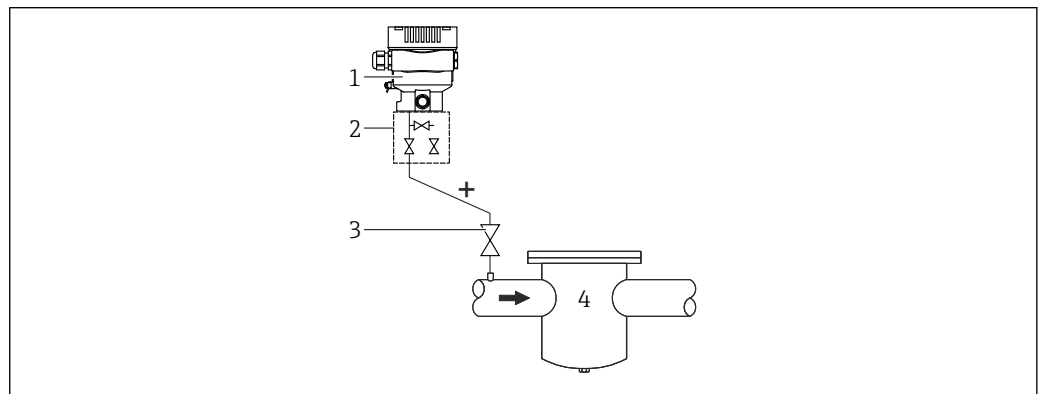

A0038218

- 1 Measuring device with blind flange on LP side
- 2 Three-valve manifold
- 3 Shutoff valves
- 4 Pressurized container

- Mount the measuring device above the measuring point so that the condensate can flow into the process piping
- The negative side is open to atmospheric pressure via the reference air filters screwed into the LP side flange

5.2.4 Differential pressure measurement

Differential pressure measurement in gases and vapors

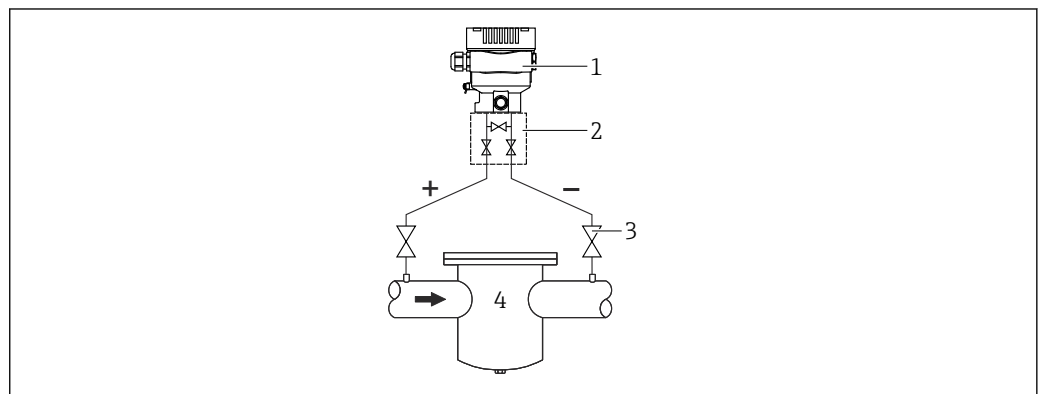

A0043423

- 1 Measuring device
- 2 Three-valve manifold
- 3 Shutoff valves
- 4 e.g. filter

Mount the measuring device above the measuring point so that condensate can flow into the process piping.

Differential pressure measurement in liquids

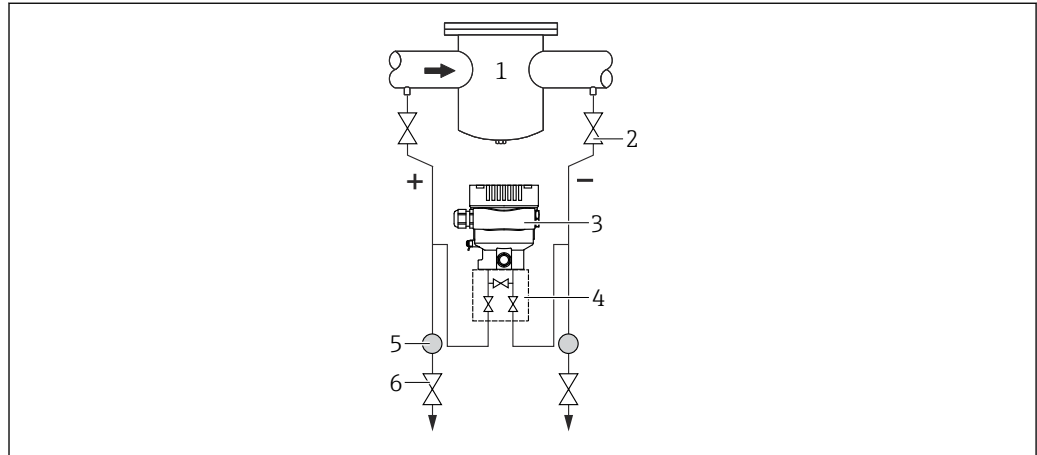

- 1 e.g. filter
 2 Shutoff valves
 3 Measuring device
 4 Three-valve manifold
 5 Separator
 6 Drain valves

- Mount the measuring device below the measuring point so that the pulse lines are always filled with liquid and gas bubbles can run back into the process piping
- When measuring in media with solid parts, such as dirty liquids, installing separators and drain valves is useful for capturing and removing sediment

5.2.5 Oxygen applications (gaseous)

Oxygen and other gases can react explosively to oils, grease and plastics. The following precautions must be taken:

- All components of the plant, such as the measuring devices, must be cleaned according to national requirements.
- Depending on the materials used, a certain maximum temperature and a maximum pressure must not be exceeded for oxygen applications.

Cleaning of the measuring device (not device accessories) is offered as an optional service.

- p_{\max} : 80 bar (1 200 psi)
- T_{\max} environment: 60 °C (140 °F)

5.2.6 Seal for flange mounting

NOTICE

Seal pressing against the process isolating diaphragm!

Incorrect measurement results!

- ▶ Ensure that the seal is not touching the process isolating diaphragm.

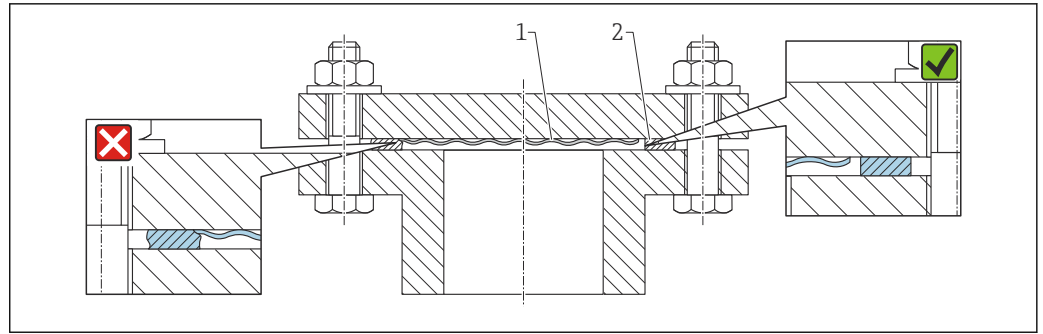

A0017743

- 1 Process isolating diaphragm
2 Seal

5.2.7 Wall and pipe mounting

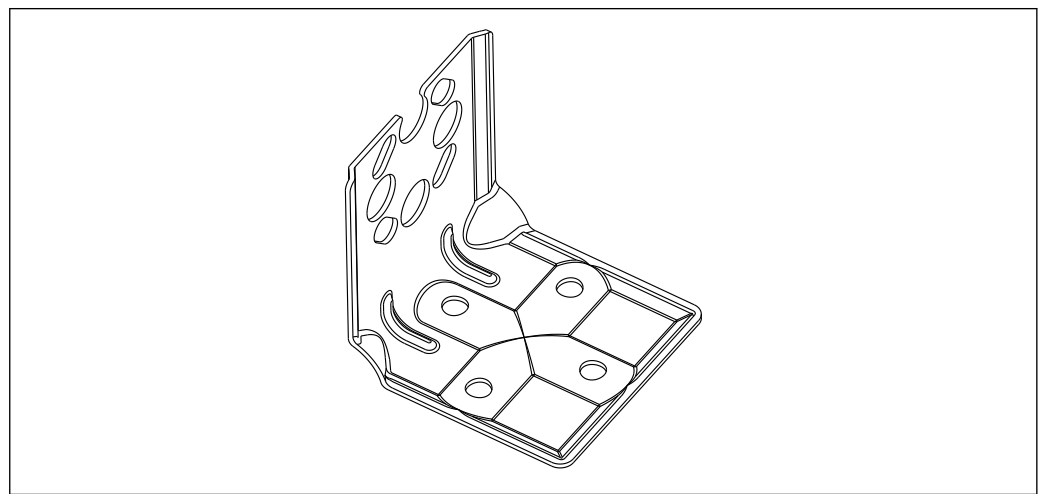

A0031326

- If a valve manifold is used, its dimensions should also be taken into consideration
- Bracket for wall and pipe mounting including retaining bracket for pipe mounting and two nuts
- The material of the screws used to secure the device depends on the order code

 For technical data (e.g. materials, dimensions or order numbers), see the accessory document SD01553P.

5.2.8 Wall and pipe mounting with a manifold (optional)

- Mount the measuring device on a shut-off device, e.g. manifold or shutoff valve
- Use the bracket provided; this makes device disassembly easier

 For technical data (e.g. materials, dimensions or order numbers), see the accessory document SD01553P.

5.2.9 Assembling and mounting the separate housing

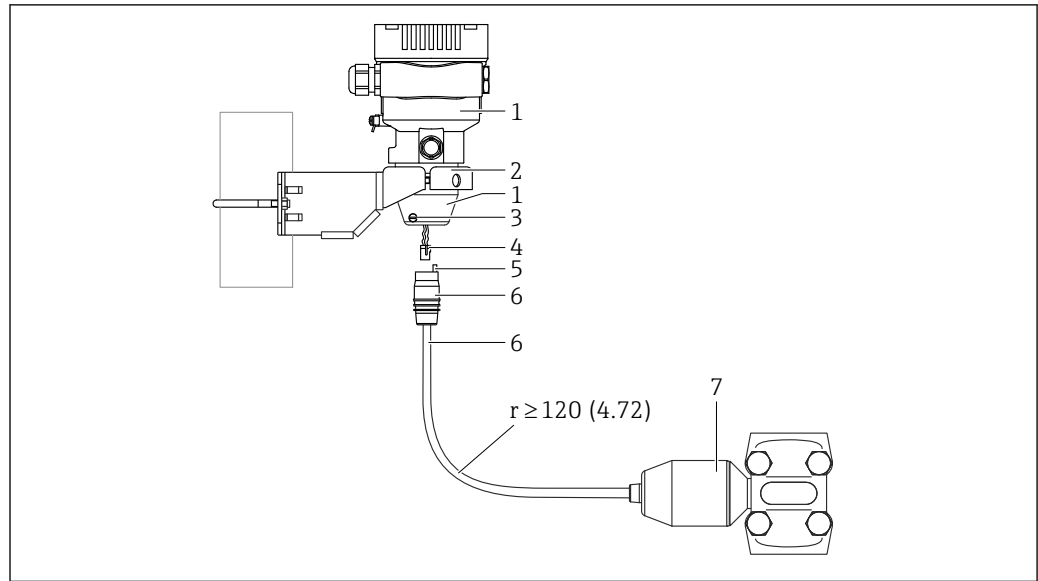

A0038725

Unit of measurement mm (in)

- 1 Housing mounted with housing adapter, included
- 2 Mounting bracket provided, suitable for pipe and wall mounting (for pipe diameters from 1 ¼" up to 2")
- 3 Locking screw
- 4 Plug
- 5 Pressure compensation
- 6 Cable with connection jack
- 7 In the separate housing version, the sensor is delivered with the process connection and cable already mounted.

Assembly and mounting

1. Insert the connector (item 4) into the corresponding connection jack of the cable (item 6).
2. Insert the cable with the socket (item 6) into the housing adapter (item 1) to the end stop.
3. Tighten the locking screw (item 3).
4. Mount the housing on a wall or pipe with the mounting bracket (item 2). When mounting on a pipe, tighten the nuts on the bracket uniformly with a torque of at least 5 Nm (3.69 lbf ft). Mount the cable with a bending radius (r) ≥ 120 mm (4.72 in).

5.2.10 Turning the display module

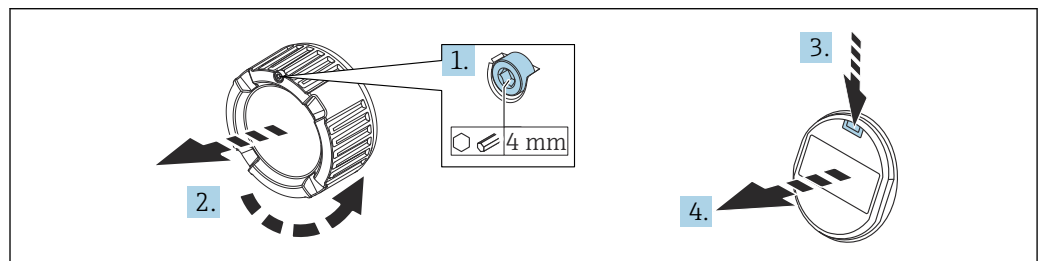

A0038224

⚠ WARNING**Supply voltage switched on!**

Risk of electric shock and/or explosion!

- ▶ Switch off the supply voltage before opening the measuring device.

⚠ CAUTION

When opening the terminal compartment cover of the dual compartment housing, your finger can get caught between the cover and pressure compensation filter.

- ▶ Open the cover slowly.

1. If fitted: release the screw of the cover lock for the electronics compartment cover using the Allen key.
2. Unscrew the electronics compartment cover from the transmitter housing and check the cover seal.
3. Press the release mechanism and remove the display module.
4. Turn the display module to the desired position: maximum $4 \times 90^\circ$ in each direction. Fit the display module on the electronics compartment in the desired position until it clicks into place. Screw the electronics compartment cover back onto the transmitter housing. If fitted: tighten the screw of the cover lock using the Allen key $0.7 \text{ Nm (0.52 lbf ft)} \pm 0.2 \text{ Nm (0.15 lbf ft)}$.

5.2.11 Closing the housing cover**NOTICE****Thread and housing cover damaged from dirt and fouling!**

- ▶ Remove fouling (e.g. sand.) on the thread of the cover and housing.
- ▶ If you continue to encounter resistance when closing the cover, check the thread again for fouling.

i Housing thread

The thread of the electronics and connection compartment is coated with lubricant varnish.

- ✘ Avoid additional lubrication.

5.2.12 Turning the housing

The housing can be rotated up to 360° by loosening the locking screw.

Your benefits

- Easy mounting due to optimum alignment of housing
- Easily accessible device operation
- Optimum readability of the onsite display (optional)

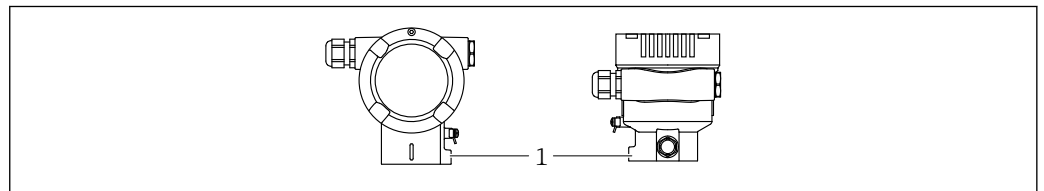

1 Locking screw

A0043807

NOTICE**The housing cannot be unscrewed fully.**

- ▶ Loosen the external locking screw by a maximum of 1.5 turns. If the screw is unscrewed too much or completely (beyond the screw anchor point), small parts (counter disk) can become loose and fall out.
- ▶ Tighten the securing screw (hex socket 4 mm (0.16 in)) with maximum 3.5 Nm (2.58 lbf ft) \pm 0.3 Nm (0.22 lbf ft).

5.3 Post-installation check

- Is the measuring device undamaged (visual inspection)?
- Are the measuring point identification and labeling correct (visual inspection)?
- Is the measuring device protected against precipitation and sunlight?
- Are the securing screws and cover lock tightened securely?
- Does the measuring device meet the measuring point specifications?
For example:
 - process temperature
 - process pressure
 - ambient temperature
 - measuring range

6 Electrical connection

6.1 Connection conditions

6.1.1 Potential equalization

The protective ground on the device must not be connected. If necessary, the potential matching line can be connected to the outer ground terminal of the transmitter before the device is connected.

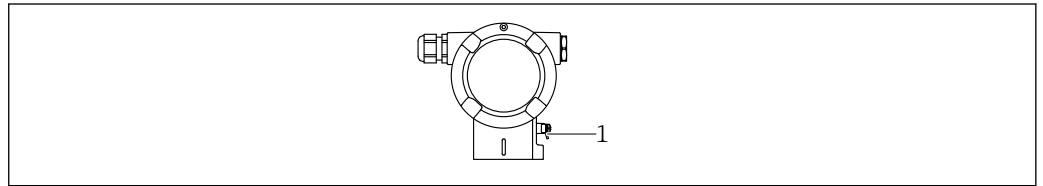

A0045412

1 Ground terminal for connecting the potential matching line

⚠ WARNING

Risk of explosion!

► Please refer to the separate documentation on applications in hazardous areas for the safety instructions.

- i** For optimum electromagnetic compatibility:
- Keep the potential matching line as short as possible
 - Maintain a cross-section of at least 2.5 mm^2 (14 AWG)

6.2 Connecting the measuring device

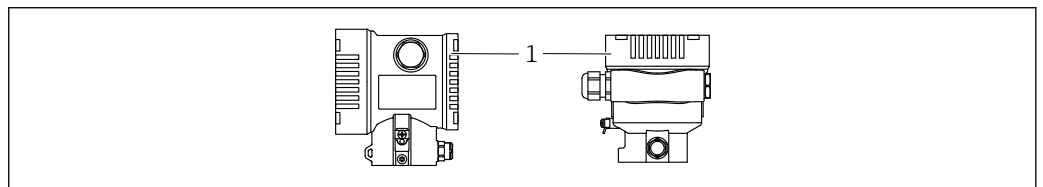

A0043806

1 Connection compartment cover

i **Housing thread**

The thread of the electronics and connection compartment is coated with lubricant varnish.

⊗ Avoid additional lubrication.

6.2.1 Supply voltage

- Ex d, Ex e, non-Ex: supply voltage: 10.5 to 35 VDC
- Ex i: supply voltage: 10.5 to 30 VDC
- Nominal current: 4 to 20 mA HART

i The power unit must be tested to ensure it meets safety requirements (e.g. PELV, SELV, Class 2).

6.2.2 Terminals

- Supply voltage and internal ground terminal: 0.5 to 2.5 mm² (20 to 14 AWG)
- External ground terminal: 0.5 to 4 mm² (20 to 12 AWG)

6.2.3 Cable specification

- Protective ground or grounding of the cable shield: rated cross-section > 1 mm² (17 AWG)
Rated cross-section of 0.5 mm² (20 AWG) to 2.5 mm² (13 AWG)
- Cable outer diameter: Ø5 to 12 mm (0.2 to 0.47 in) depends on the cable gland used (see the Technical Information)

6.2.4 4-20 mA HART

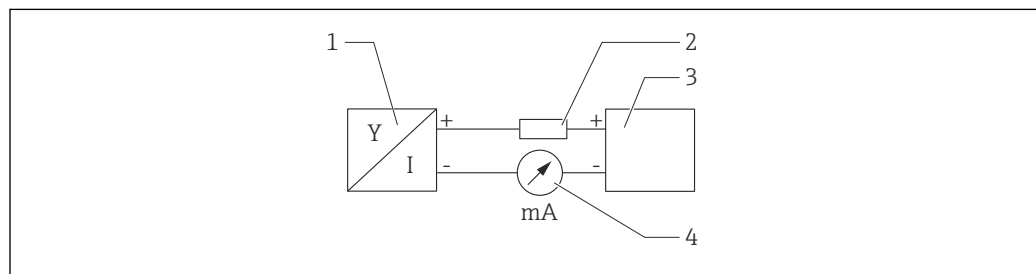

 2 Block diagram of HART connection

- 1 Measuring device with HART communication
- 2 HART communication resistor
- 3 Power supply
- 4 Manometer

 The HART communication resistor of 250 Ω in the signal line is always necessary in the case of a low-impedance power supply.

Take the voltage drop into consideration:

Maximum 6 V for a 250 Ω communication resistor

6.2.5 Overvoltage protection

Devices without optional overvoltage protection

Equipment from Endress+Hauser fulfills the requirements of the product standard IEC / DIN EN 61326-1 (Table 2 Industrial Environment).

Depending on the type of port (DC power supply, input/output port) different testing levels according to IEC / DIN EN 61326-1 against transient overvoltages (Surge) are applied (IEC / DIN EN 61000-4-5 Surge):

Test level on DC power ports and input / output ports is 1000 V line to earth

Devices with optional overvoltage protection

- Spark-over voltage: min. 400 V DC
- Tested according to IEC / DIN EN 60079-14 sub chapter 12.3 (IEC / DIN EN 60060-1 chapter 7)
- Nominal discharge current: 10 kA

Overvoltage category

Overvoltage category II

6.2.6 Wiring

⚠ WARNING

Supply voltage might be connected!

Risk of electric shock and/or explosion!

- ▶ If the device is used in hazardous areas, make sure to comply with national standards and the specifications in the Safety Instructions (XAs). The specified cable gland must be used.
- ▶ The supply voltage must match the specifications on the nameplate.
- ▶ Switch off the supply voltage before connecting the device.
- ▶ If necessary, the potential matching line can be connected to the outer ground terminal of the transmitter before the device is connected.
- ▶ A suitable circuit breaker should be provided for the device in accordance with IEC/EN 61010.
- ▶ The cables must be adequately insulated, with due consideration given to the supply voltage and the overvoltage category.
- ▶ The connecting cables must offer adequate temperature stability, with due consideration given to the ambient temperature.
- ▶ Only operate the measuring device with the covers closed.

Connect the device in the following order:

1. Release the cover lock (if provided).
2. Unscrew the cover.
3. Guide the cables into the cable glands or cable entries.
4. Connect the cables.
5. Tighten the cable glands or cable entries so that they are leak-tight. Counter-tighten the housing entry.
6. Screw the cover securely back onto the connection compartment.
7. If fitted: tighten the screw of the cover lock using the Allen key 0.7 Nm (0.52 lbf ft) \pm 0.2 Nm (0.15 lbf ft).

6.2.7 Terminal assignment

Single compartment housing

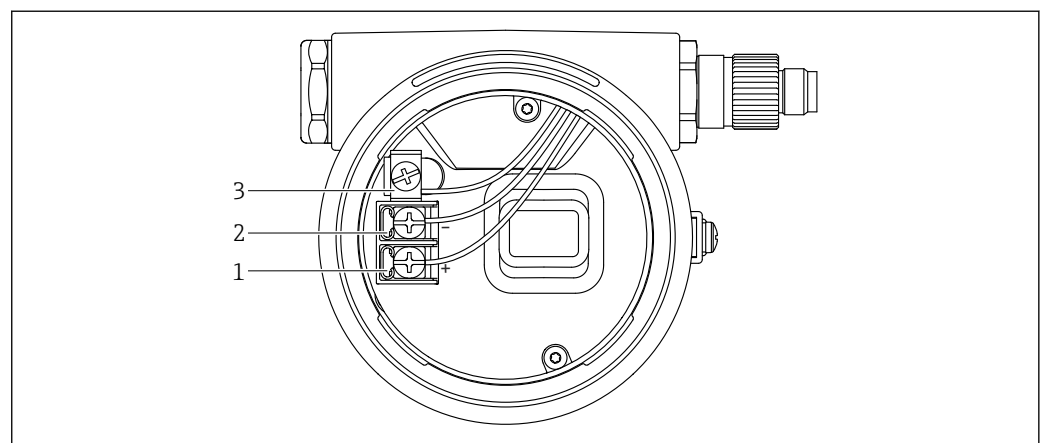

3 Connection terminals and ground terminal in the connection compartment

- 1 Positive terminal
- 2 Negative terminal
- 3 Internal ground terminal

A0042594

Dual compartment housing

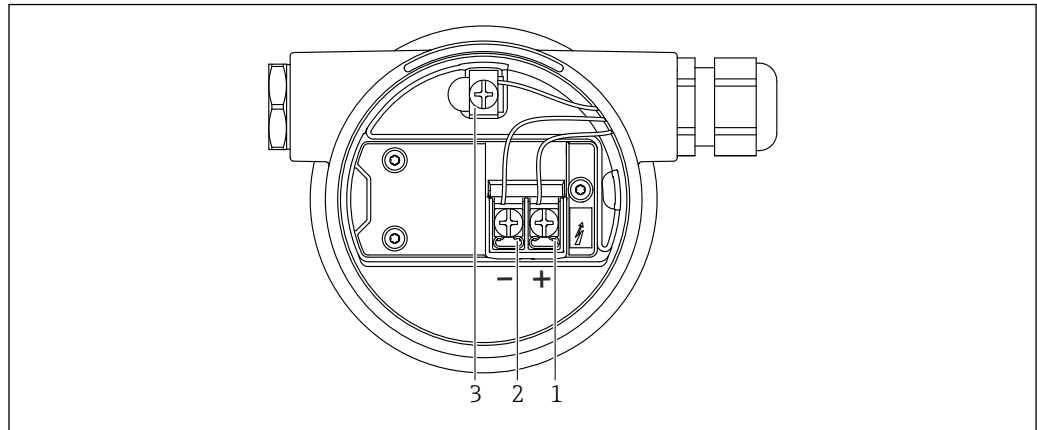

A0042803

 4 Connection terminals and ground terminal in the connection compartment

- 1 Positive terminal
- 2 Negative terminal
- 3 Internal ground terminal

6.2.8 Cable entries

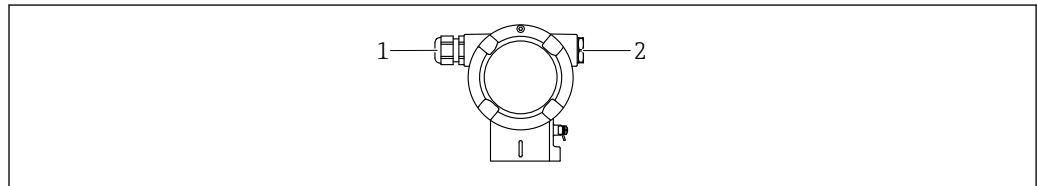

A0045414

- 1 Cable entry
- 2 Dummy plug

A0045413

The type of cable entry depends on the device version ordered.

 Always route connecting cables downwards so that moisture cannot penetrate the connection compartment.

If necessary, create a drip loop or use a weather protection cover.

6.2.9 Available device plugs

 In the case of devices with a plug, the housing does not have to be opened to establish the connection.

Use the enclosed seals to prevent the penetration of moisture into the device.

Measuring devices with M12 plug

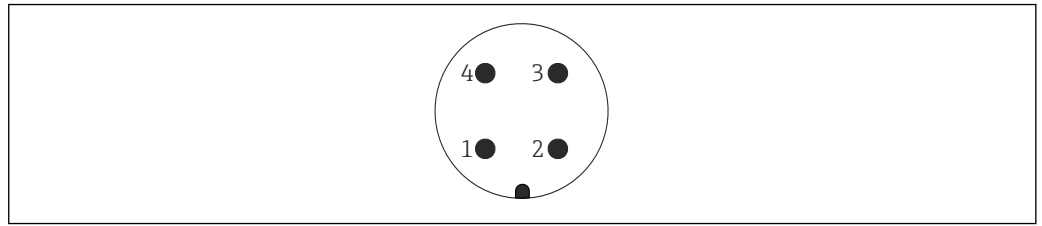

A0011175

- 1 Signal +
- 2 Not assigned
- 3 Signal -
- 4 Ground

Measuring devices with Harting plug Han7D

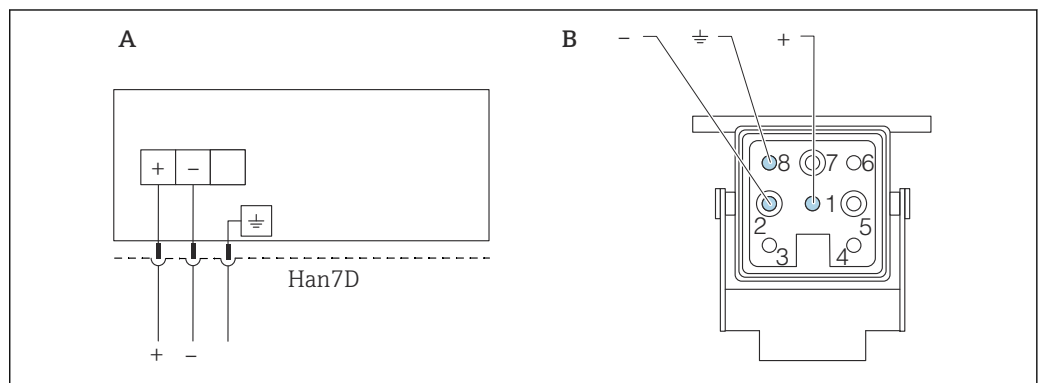

A0041011

- A Electrical connection for devices with Harting plug Han7D
- B View of the plug-in connection on the device

6.3 Ensuring the degree of protection

6.3.1 Cable entries

- Gland M20, plastic, IP66/68 TYPE 4X/6P
- Gland M20, brass nickel plated, IP66/68 TYPE 4X/6P
- Gland M20, 316L, IP66/68 TYPE 4X/6P
- Thread M20, IP66/68 TYPE 4X/6P
- Thread G1/2, IP66/68 TYPE 4X/6P
 - If the G1/2 thread is selected, the device is delivered with an M20 thread as standard and a G1/2 adapter is included with the delivery, along with the corresponding documentation
- Thread NPT1/2, IP66/68 TYPE 4X/6P
- Dummy plug transport protection: IP22, TYPE 2
- Plug HAN7D, 90 deg. IP65 NEMA Type 4X
- Plug M12
 - When housing is closed and connecting cable is plugged in: IP66/67, NEMA Type 4X
 - When housing is open or connecting cable is not plugged in: IP20, NEMA Type 1

NOTICE**Plug M12 and plug HAN7D: incorrect mounting can invalidate the IP protection class!**

- ▶ The degree of protection only applies if the connecting cable used is plugged in and screwed tight.
- ▶ The degree of protection only applies if the connecting cable used is specified according to IP67, NEMA Type 4X.
- ▶ The IP protection classes are only maintained if the dummy cap is used or the cable is connected.

6.4 Post-connection check

After wiring the device, carry out the following checks:

- Is the potential matching line connected?
- Is the terminal assignment correct?
- Are the cable glands and dummy plugs leak-tight?
- Are the fieldbus connectors properly secured?
- Are the covers screwed down correctly?

7 Operation options

7.1 Overview of operation options

- Operation via operating keys and DIP switches on the electronic insert
- Operation via optical operating keys on the device display (optional)
- Operation via Bluetooth® wireless technology (with optional Bluetooth device display) with SmartBlue App or FieldXpert, DeviceCare
- Operation via operating tool (Endress+Hauser FieldCare/DeviceCare or AMS, PDM, etc.)
- Operation via handheld, Fieldcare, DeviceCare, AMS and PDM

7.2 Operating keys and DIP switches on the electronic insert

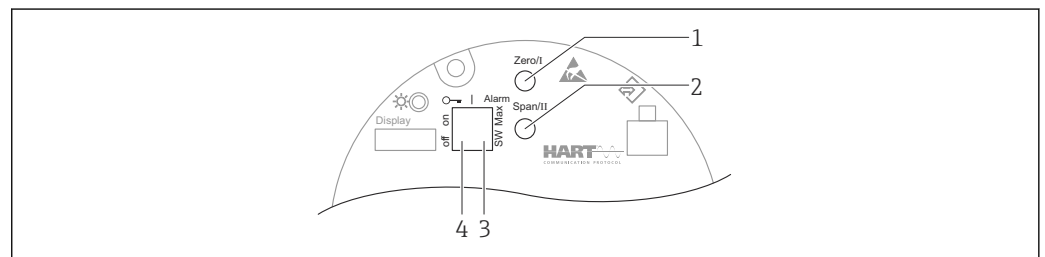

A0039285

- 1 Operating key for lower range value (Zero)
- 2 Operating key for upper range value (Span)
- 3 DIP switch for alarm current
- 4 DIP switch for locking and unlocking the measuring device

7.3 Structure and function of the operating menu

The differences between the structure of the operating menus of the local display and the Endress+Hauser FieldCare or DeviceCare operating tools can be summarized as follows:

The local display is suitable for configuring simple applications.

More elaborate applications can be configured with the Endress+Hauser FieldCare or DeviceCare tools as well as Bluetooth and the SmartBlue App and the device display.

"Wizards" help the user to commission the various applications. The user is guided through the individual configuration steps.

7.3.1 User roles and related access authorization

The two user roles **"Operator" option** and **"Maintenance" option** (as-delivered state) have different write access to the parameters if a device-specific access code has been defined. This access code protects the device configuration from unauthorized access.

If an incorrect access code is entered, the user obtains the access rights of the **"Operator" option** user role.

7.4 Access to the operating menu via the local display

7.4.1 Device display (optional)

Functions:

- Display of measured values and fault and notice messages
- Background lighting, which switches from green to red in the event of an error
- The device display can be removed for easier operation

i Backlighting is switched on or off depending on the supply voltage and the current consumption.

i The device displays are available with the additional option of Bluetooth® wireless technology.

Bluetooth is switched on or off depending on the supply voltage and the current consumption.

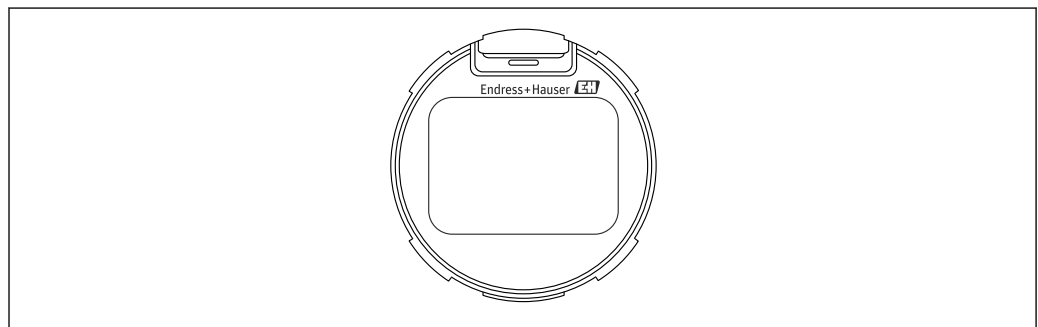





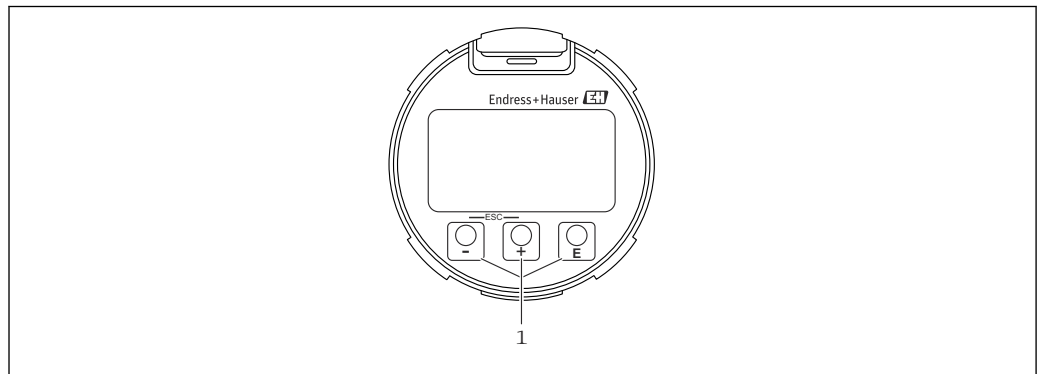

A0043059

5 Segment display



A0039284

6 Graphic display with optical operating keys (1)

- Key 
 - Navigate downwards in the picklist
 - Edit the numerical values or characters within a function
- Key 
 - Navigate upwards in the picklist
 - Edit the numerical values or characters within a function
- Key 
 - Confirm entry
 - Jump to the next item
 - Select a menu item and activate the edit mode
 - Unlock/lock the display operation
 - Press and hold the  key to display a short description of the selected parameter (if available)
-  key and  key (ESC function)
 - Exit edit mode for a parameter without saving the changed value
 - Menu at a selection level: pressing the keys simultaneously takes the user back up a level in the menu
 - Press and hold the keys simultaneously to return to the upper level

7.4.2 Operation via Bluetooth® wireless technology (optional)

Prerequisite

- Measuring device with Bluetooth display
- Smartphone or tablet with Endress+Hauser SmartBlue App or PC with DeviceCare, version 1.07.00 and higher, or FieldXpert SMT70

The connection range is up to 25 m (82 ft). The range can vary depending on ambient conditions such as fixtures, walls or ceilings.

-  The operating keys on the display are locked as soon as the device is connected via Bluetooth.

SmartBlue App

1. Scan the QR code or enter "SmartBlue" in the search field of the App Store or Google Play.

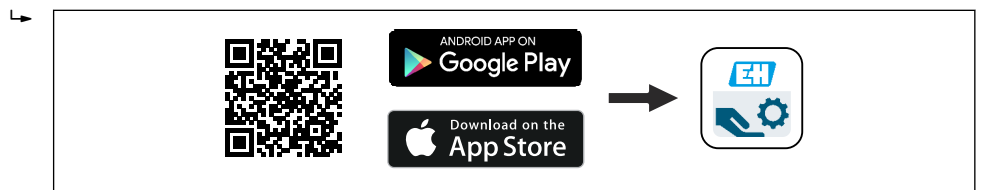

A0039186

2. Start the SmartBlue App.
3. Select the measuring device from the Live list displayed.
4. Login:
 - ↳ Enter the user name: admin
 - Password: serial number of the device.
5. Change the password after logging in for the first time!

Prerequisites

System requirements

The SmartBlue App is available for download on a smartphone or tablet.

- iOS devices: iPhone 5S or higher from iOS11; iPad 5th Generation or higher from iOS11; iPod Touch 6th Generation or higher from iOS11
- Devices with Android: from Android 6.0 and Bluetooth® 4.0

Initial password

The serial number of the device serves as the initial password when the connection is established for the first time.

 It is important to note the following if the Bluetooth module is removed from one device and installed in another device: the password changed by the user is only stored in the Bluetooth module and not in the device.

7.5 Access to the operating menu via the operating tool

Access via the operating tool is possible:

- Via HART communication
- Via Endress+Hauser Commubox FXA291
With the Commubox FXA291, a CDI connection can be established between the measuring device interface and a Windows PC/notebook with a USB port

7.6 HistoROM

If the electronic insert is replaced, the stored data (excluding the event list) are transferred by unplugging the HistoROM module and plugging it into the new electronic insert.

The device serial number is saved in the HistoROM. The electronics serial number is saved in the electronics.

8 System integration

8.1 Overview of device description files

- Manufacturer ID: 17 (0x0011)
- Device type ID: 0x1131
- HART specification: 7.6
- DD files, information and files can be found at:
 - www.endress.com
 - www.fieldcommgroup.org

8.2 Measured variables via HART protocol

The following measured values are assigned to the device variables at the factory:

Device variable	Measured value
Primary variable (PV) ¹⁾	Pressure ²⁾
Secondary variable (SV)	Sensor temperature
Tertiary variable (TV)	Electronics temperature
Quaternary variable (QV)	Sensor pressure ³⁾

- 1) The PV is always applied to the current output.
- 2) The pressure is the calculated signal after damping and position adjustment.
- 3) The sensor pressure is the raw sensor signal before damping and position adjustment.

 The assignment of the measured values to the device variables can be changed in the following submenu:
Application → HART output → HART output

 In a HART Multidrop loop, only one device may use the analog current value for signal transmission. For all other devices in the "**Loop current mode**" parameter, select the **Disable** option.

8.2.1 Device variables and measured values

The following codes are assigned to the device variables at the factory:

Device variable	Device variable code
Pressure	0
Scaled variable	1
Sensor temperature	2
Sensor pressure	3
Electronics temperature	4
Terminal current	5
Terminal voltage	6
Median of pressure signal	7
Noise of pressure signal	8
Percent of range	244

Device variable	Device variable code
Loop current	245
Not used	250

 The device variables can be queried by a HART® master using HART® command 9 or 33.

8.2.2 System units

The following table describes the supported pressure measuring units.

Index number	Description	Hart unit code
0	mbar	8
1	bar	7
2	Pa	11
3	kPa	12
4	MPa	237
5	psi	6
6	torr	13
7	atm	14
8	mmH ₂ O	4
9	mmH ₂ O (4°C)	239
10	mH ₂ O	240
11	mH ₂ O (4°C)	240
10	ftH ₂ O	3
11	inH ₂ O	1
12	inH ₂ O (4°C)	238
13	mmHg	5
14	inHg	2
15	gf/cm ²	9
16	kgf/cm ²	10

9 Commissioning

9.1 Preparatory steps

The measuring range and the unit in which the measured value is transmitted correspond to the data on the nameplate.

WARNING

The settings of the current output are relevant for safety!

This can result in product overflow.

- ▶ The setting for the current output depends on the setting in the **Assign PV** parameter.
- ▶ After changing the setting for the current output, check the setting for the span (LRV and URV) and readjust it if necessary!

WARNING

Process pressure above or below permitted maximum/minimum!

Risk of injury if parts burst! Warning messages are generated if pressure is too high.

- ▶ If a pressure smaller than the minimum permitted pressure or greater than the maximum permitted pressure is present at the device, a message is output.
- ▶ Use the device only within the sensor range limits!

9.1.1 As-delivered state

If no customized settings were ordered:

- **Assign PV** parameter **Pressure** option
- Calibration values defined by defined sensor nominal value
- The alarm current is set to min. (3.6 mA), (only if no other option was selected when ordering)
- DIP switch to Off position
- Bluetooth switched on

9.2 Function check

Perform a function check before putting the measuring point into operation:

- "Post-installation check" checklist (see the "Installation" section)
- "Post-connection check" checklist (see the "Electrical connection" section)

9.3 Switching on the measuring device

i All configuration tools offer a commissioning wizard that helps the user to configure the most important configuration parameters (**Guidance** menu **Commissioning** wizard).

9.4 Establishing a connection via FieldCare and DeviceCare

9.4.1 Via HART protocol

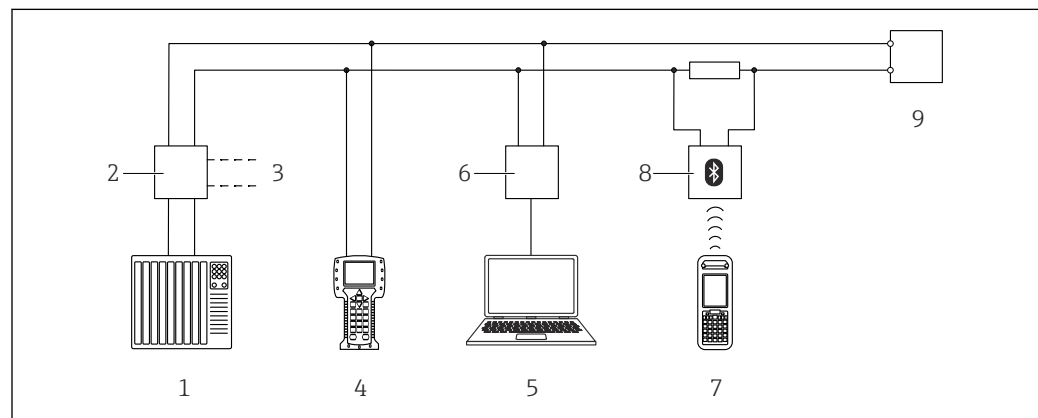

A0036169

7 Options for remote operation via HART protocol

- 1 PLC (programmable logic controller)
- 2 Transmitter power supply unit, e.g. RN221N (with communication resistor)
- 3 Connection for Commubox FXA195 and Field Communicator 375, 475
- 4 Field Communicator 475
- 5 Computer with operating tool (e.g. FieldCare/DeviceCare, AMS Device Manager, SIMATIC PDM)
- 6 Commubox FXA195 (USB)
- 7 Field Xpert SFX350/SFX370
- 8 VIATOR Bluetooth modem with connecting cable
- 9 Measuring device

9.4.2 FieldCare/DeviceCare via service interface (CDI)

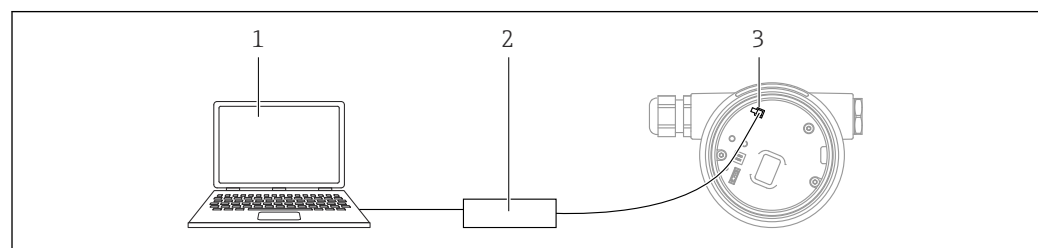

A0039148

- 1 Computer with FieldCare/DeviceCare operating tool
- 2 Commubox FXA291
- 3 Service interface (CDI) of the measuring device (= Endress+Hauser Common Data Interface)

i At least 22 mA is required to update (flash) the device firmware.

9.5 Configuring the device address via software

See the **HART address** parameter.

Menu path: Application → HART output → Configuration → HART address

9.6 Setting the operating language

9.6.1 Local display

- In the main menu, select the **Language** parameter
Press the $\boxed{\text{E}}$ key
- Select the desired language with the $\boxed{+}$ or $\boxed{-}$ key
Press the $\boxed{\text{E}}$ key

Display operation - locking or unlocking

The $\boxed{\text{E}}$ key must be pressed for at least 2 seconds in order to lock or unlock the optical keys. Display operation can be locked or unlocked in the dialog that appears.

Display operation locks automatically (except in the SIL wizard):

- After 1 minute on the main page if no key has been pressed
- After 10 minutes within the operating menu if no key has been pressed

9.6.2 FieldCare

In the "Extras" menu, click "Options".

Set the preferred language for FieldCare in the "Language" section.

Setting the language for the local display via FieldCare

Set the preferred language in the **Language** parameter.

Menu path: System → Display → Language

9.7 Configuring the measuring device

9.7.1 Clean the piping if necessary

Differential pressure measurement

Before the device is adjusted, the pressure piping must be cleaned, where necessary, and filled with fluid.

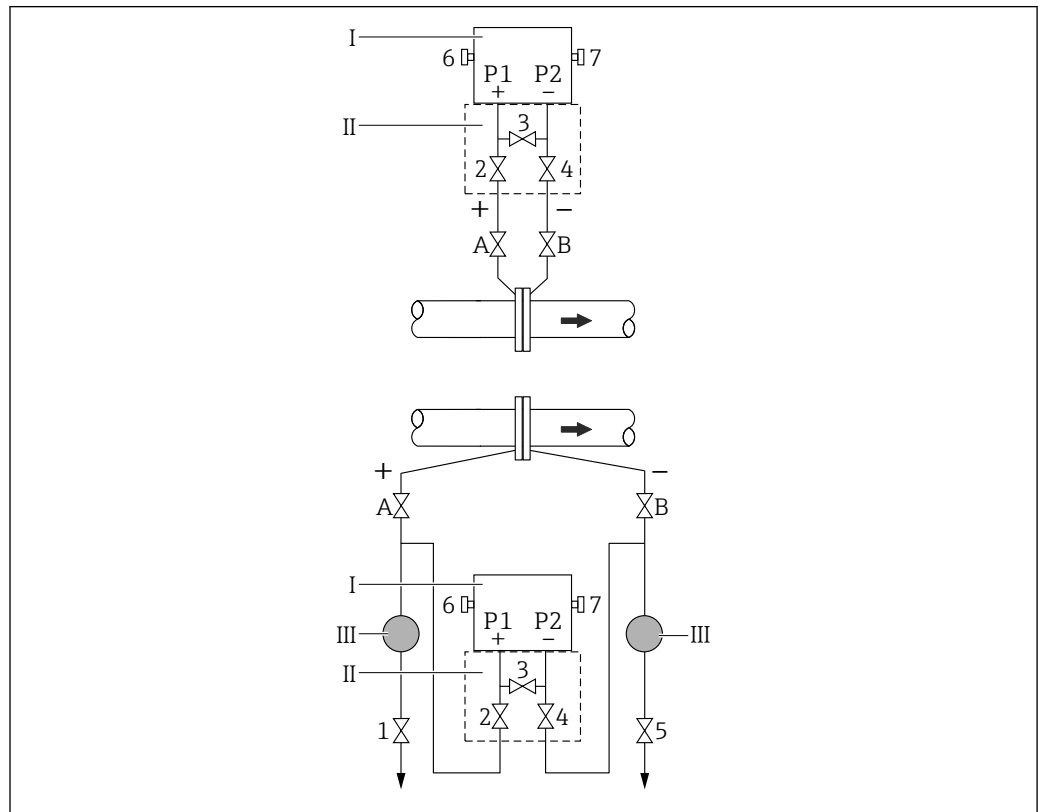

A0030036

- I Measuring device
- II Three-valve manifold
- III Separator
- 1, 5 Drain valves
- 2, 4 Inlet valves
- 3 Equalizing valve
- 6, 7 Vent valves on the measuring device
- A, B Shutoff valve

Top diagram: preferred installation for gases

Bottom diagram: preferred installation for liquids

1. Close 3.
2. Fill measuring system with fluid.
 - ↳ Open A, B, 2, 4. Fluid flows in.
3. Clean the pressure piping if it is blocked (for arrangements with 5 valves).
 - ↳ By blowing out with compressed air in the case of gases. By rinsing out in the case of liquids.
 - Close 2 and 4 (seal off the measuring device).
 - Open 1 and 5 (blow clear/rinse pressure piping (for arrangements with 5 valves)).
 - Close 1 and 5 (close valves after cleaning (for arrangements with 5 valves)).

4. Vent the measuring device.
 - ↳ Open 2 and 4 (introduce fluid).
 - Close 4 (low-pressure side).
 - Open 3 (balance high-pressure and low-pressure side).
 - Open 6 and 7 briefly, then close them again (fill the measuring device completely with fluid and remove air).
5. Set measuring point to operation.
 - ↳ Close 3 (separate high-pressure side and low-pressure side).
 - Open 4 (connect low-pressure side).

Now:

1 (for arrangements with 5 valves), 3, 5 (for arrangements with 5 valves), 6 and 7 are closed.

2 and 4 are open.

A and B are open (if present).

 Check the adjustment and perform it again if necessary.

Flow measurement

Before the device is adjusted, the pressure piping must be cleaned, where necessary, and filled with fluid.

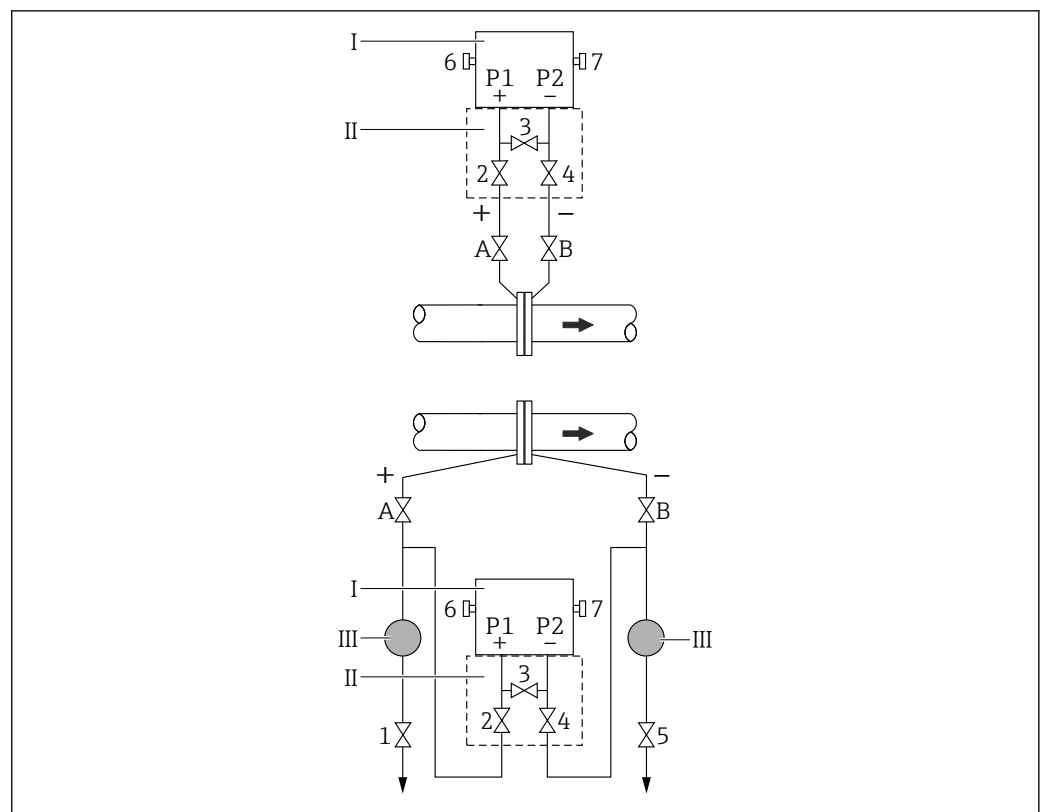

- I Measuring device
 II Three-valve manifold
 III Separator
 1, 5 Drain valves
 2, 4 Inlet valves
 3 Equalizing valve
 6, 7 Vent valves on the measuring device
 A, B Shutoff valve

A0030036

Top diagram: preferred installation for gases

Bottom diagram: preferred installation for liquids

1. Close 3.
2. Fill measuring system with fluid.
 - ↳ Open A, B, 2, 4 (fluid flows in).
3. Clean the pressure piping if it is blocked (for arrangements with 5 valves).
 - ↳ By blowing out with compressed air in the case of gases. By rinsing out in the case of liquids.
Close 2 and 4 (seal off the measuring device).
Open 1 and 5 (blow clear/rinse pressure piping (for arrangements with 5 valves)).
Close 1 and 5 (close valves after cleaning (for arrangements with 5 valves)).
4. Vent the measuring device.
 - ↳ Open 2 and 4 (introduce fluid).
Close 4 (low-pressure side).
Open 3 (balance high-pressure and low-pressure side).
Open 6 and 7 briefly, then close them again (fill the measuring device completely with fluid and remove air).
5. Perform zero adjustment if the following conditions apply. If the conditions are not met, then do not carry out the pos. zero adjustment until after step 6.
 - ↳ Conditions:
The process cannot be blocked off.
The tapping points (A and B) are at the same geodetic height.
6. Set measuring point to operation.
 - ↳ Close 3 (separate high-pressure side and low-pressure side).
Open 4 (connect low-pressure side).

Now:

1 (for arrangements with 5 valves), 3, 5 (for arrangements with 5 valves), 6 and 7 are closed.

2 and 4 are open.

A and B are open (if present).

-  Perform zero adjustment if the flow can be shut off.
Check the adjustment and perform it again if necessary.

Level measurement

Open vessel

Before the device is adjusted, the pressure piping must be cleaned, where necessary, and filled with fluid.

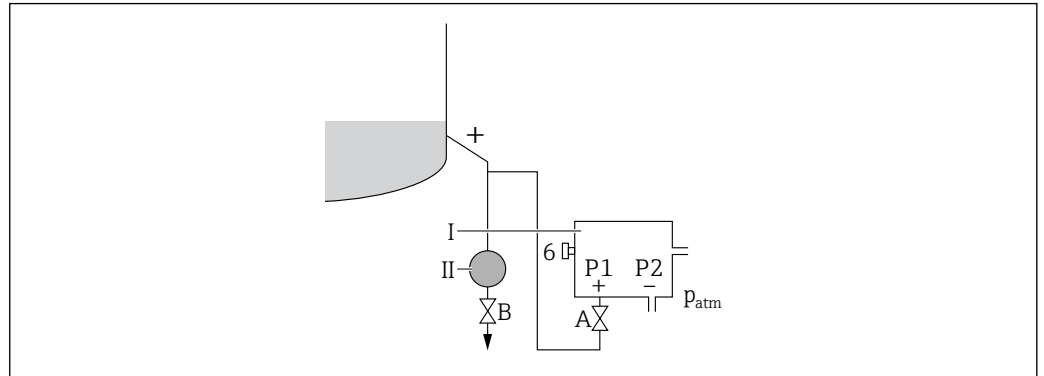

- I Measuring device
- II Separator
- 6 Vent valve on measuring device
- A Shutoff valve
- B Drain valve

1. Fill vessel to a level above the lower tap.
2. Fill measuring system with fluid.
 - ↳ Open A (shutoff valve).
3. Vent the measuring device.
 - ↳ Open 6 briefly, then close it again (fill the measuring device completely with fluid and remove air).
4. Set measuring point to operation.
 - ↳ Now:
 - B and 6 are closed.
 - A is open.

Closed vessel

Before the device is adjusted, the pressure piping must be cleaned, where necessary, and filled with fluid.

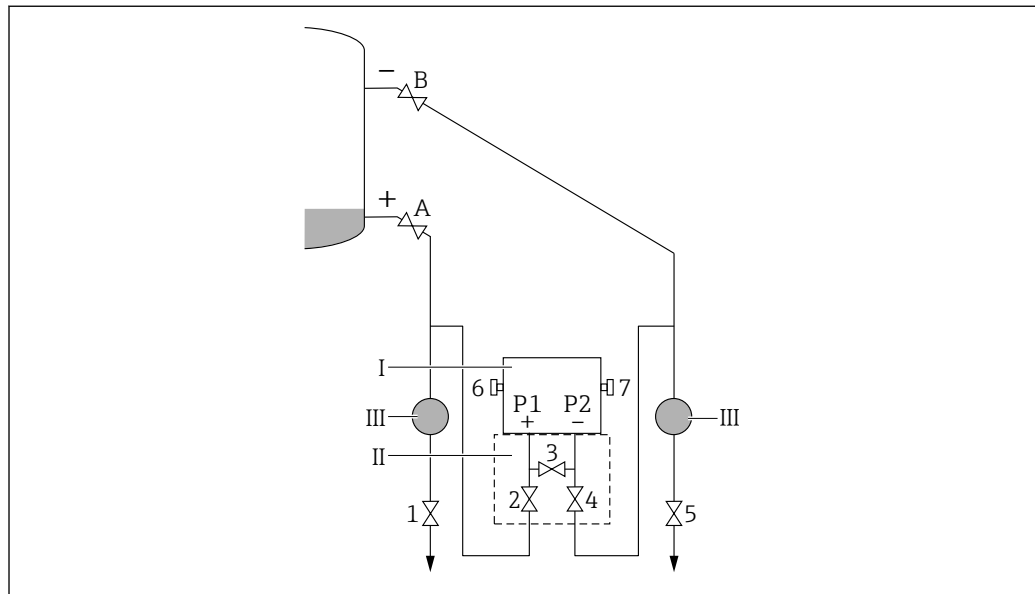

A0030039

- I Measuring device
- II Three-valve manifold
- III Separator
- 1, 5 Drain valves
- 2, 4 Inlet valves
- 3 Equalizing valve
- 6, 7 Vent valves on the measuring device
- A, B Shut-off valves

1. Fill vessel to a level above the lower tap.
2. Fill measuring system with fluid.
 - ↳ Close 3 (separate high-pressure side and low-pressure side).
Open A and B (shutoff valves).
3. Vent high-pressure side (empty low-pressure side if necessary).
 - ↳ Open 2 and 4 (introduce fluid on high-pressure side).
Open 6 and 7 briefly, then close them again (fill the high-pressure side completely with fluid and remove air)
4. Set measuring point to operation.
 - ↳ Now:
3, 6 and 7 are closed.
2, 4, A and B are open.

Closed vessel with superimposed vapor

Before the device is adjusted, the pressure piping must be cleaned, where necessary, and filled with fluid.

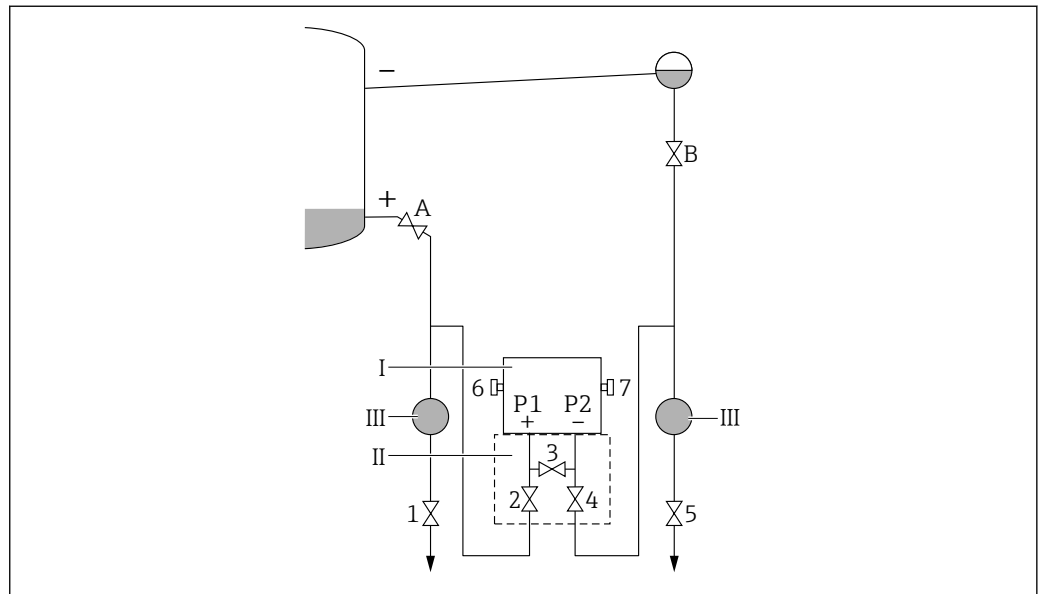

A0030040

- I Measuring device
- II Three-valve manifold
- III Separator
- 1, 5 Drain valves
- 2, 4 Inlet valves
- 3 Equalizing valve
- 6, 7 Vent valves on the measuring device
- A, B Shut-off valves

1. Fill vessel to a level above the lower tap.
2. Fill measuring system with fluid.
 - ↳ Open A and B (shutoff valves).
Fill the negative pressure piping to the level of the condensate trap.
3. Vent the measuring device.
 - ↳ Open 2 and 4 (introduce fluid).
Close 4 (low-pressure side).
Open 3 (balance high-pressure and low-pressure side).
Open 6 briefly, then close it again (fill the measuring device completely with fluid and remove air).
4. Set measuring point to operation.
 - ↳ Close 3 (separate high-pressure side and low-pressure side).
Open 4 (connect low-pressure side).
Now:
B and 6 are closed.
A is open.

9.7.2 Commissioning with keys on the electronic insert

The following functions are possible by means of the keys on the electronic insert:

- Position adjustment (zero point correction)
 - The orientation of the measuring device may cause a pressure shift
 - This pressure shift can be corrected by a position adjustment
- Setting of the lower range value and upper range value
 - The pressure applied must be within the nominal pressure limits of the sensor (see the specifications on the nameplate)
- Resetting the device

Performing position adjustment

1. Pressure is present at the device.
2. Press the "Zero" and "Span" keys simultaneously for at least 3 s.
3. Does the LED on the electronic insert light up briefly?
 - ↳ Applied pressure for position adjustment has been accepted.
4. Does the LED on the electronic insert not light up?
 - ↳ Applied pressure for position adjustment has not been accepted. Pay attention to the entry limits.

Setting the lower range value (pressure or scaled variable)

1. Desired pressure for lower range value is present at the device.
2. Press the "Zero" key for at least 3 s.
3. Does the LED on the electronic insert light up briefly?
 - ↳ Applied pressure for lower range value has been accepted.
4. Does the LED on the electronic insert not light up?
 - ↳ Applied pressure for lower range value has not been accepted. Pay attention to the entry limits.

Setting the upper range value (pressure or scaled variable)

1. Desired pressure for upper range value is present at the device.
2. Press the "Span" key for at least 3 s.
3. Does the LED on the electronic insert light up briefly?
 - ↳ Applied pressure for upper range value has been accepted.
4. Does the LED on the electronic insert not light up?
 - ↳ Applied pressure for upper range value has not been accepted. Pay attention to the entry limits.

If the option selected in the **Assign PV** parameter is the **Scaled variable** option and the option selected in the **Scaled variable transfer function** parameter is the **Table** option, wet calibration is not possible.

Checking the settings (pressure or scaled variable)

1. Press the "Zero" key briefly to display the lower range value.
2. Press the "Span" key briefly to display the upper range value.
3. Briefly press the "Zero" and "Span" keys simultaneously to display the position offset.

Resetting the device

- ▶ Press and hold the "Zero" and "Span" keys simultaneously for at least 12 seconds.

9.7.3 Commissioning with the commissioning wizard

In FieldCare, DeviceCare ¹⁾, SmartBlue and the display, the **Commissioning** wizard is available that guides the user through the initial commissioning process.

1. Connect the device with FieldCare or DeviceCare.
 2. Open the device in FieldCare or DeviceCare.
 - ↳ The dashboard (homepage) of the device is displayed:
 3. In the **Guidance** menu, click the **Commissioning** wizard to launch the wizard.
 4. Enter the appropriate value in each parameter or select the appropriate option. These values are written directly to the device.
 5. Click "Next" to go to the next page.
 6. Once all the pages have been completed, click "Finish" to close the **Commissioning** wizard.
-  If you cancel the **Commissioning** wizard before all the necessary parameters have been entered, the device may be in an undefined state. In such situations, it is advisable to reset the device to the factory default settings.

1) DeviceCare is available for download at www.software-products.endress.com. To download the software, it is necessary to register in the Endress+Hauser software portal.

Example: Outputting of the pressure value at the current output

i Pressure and temperature units are converted automatically. Other units are not converted.

In the following example, the pressure value should be measured in a tank and output on the current output. The maximum pressure of 450 mbar (6.75 psi) corresponds to the 20 mA current. The 4 mA current corresponds to a pressure of 50 mbar (0.75 psi).

Prerequisites:

- Measured variable in direct proportion to the pressure
- Due to the orientation of the measuring device, there may be pressure shifts in the measured value (when the vessel is empty or partly filled, the measured value is not zero)
Perform a position adjustment if necessary
- In the **Assign PV** parameter, the **Pressure** option must be set (factory setting)
Display: In the **Guidance** menu **Commissioning** wizard, keep pressing the **+** key until the **Assign PV** parameter is reached. Confirm with the **↵** key, select the **Pressure** option and press the **↵** key to confirm.

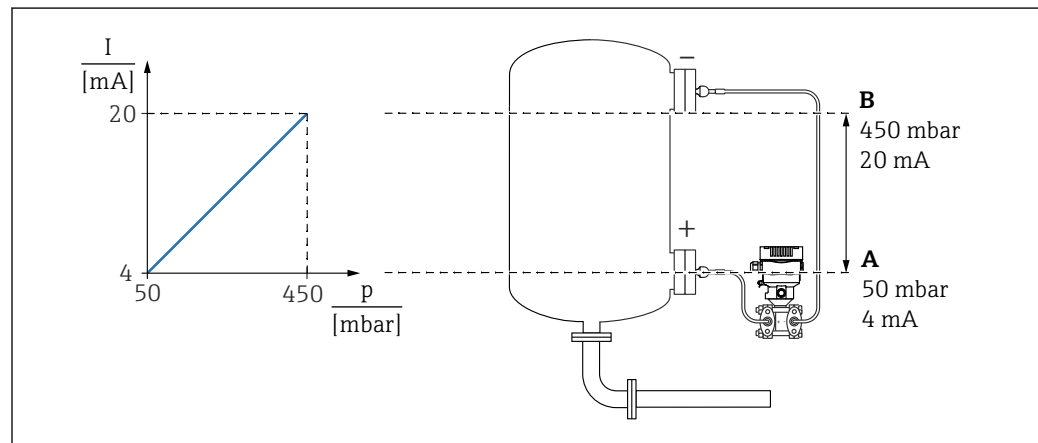

A0039093

- A Lower range value output
B Upper range value output

Adjustment:

1. Enter the pressure value for the 4 mA current via the **Lower range value output** parameter (50 mbar (0.75 psi)).
2. Enter the pressure value for the 20 mA current via the **Upper range value output** parameter (450 mbar (6.75 psi))

Result: The measuring range is set to 4 to 20 mA.

Example: Outputting of the flow value at the current output

In the following example, the flow value should be measured and output at the current output.

- Perform position adjustment if necessary
- Output the flow signal 0 to 100 m³/h as a 4 to 20 mA value
100 m³/h corresponds to 30 mbar (0.435 psi)

Menu path: Guidance → Commissioning

- In the **Assign PV** parameter, select the **Scaled variable** option
- In the **Pressure unit** parameter and **Scaled variable unit** parameter, select the desired unit
- In the **Output current transfer function** parameter, select the **Square** option
- **Pressure value 1** parameter / **Scaled variable value 1** parameter
Enter 0 mbar (0 psi) / 0 m³/h
- **Pressure value 2** parameter / **Scaled variable value 2** parameter
Enter 30 mbar (0.435 psi) / 100 m³/h

Proceed as follows if the flow does not have to be displayed as a measured value and only a square root extraction should be output.

Menu path: Guidance → Commissioning

- In the **Assign PV** parameter, select the **Pressure** option
- In the **Output current transfer function** parameter, select the **Square** option
- In the **Lower range value output** parameter, enter 0 mbar (0 psi)
- In the **Upper range value output** parameter, enter 30 mbar (0.435 psi)

9.7.4 Commissioning without the commissioning wizard

Example: Commissioning a volume measurement in the tank

i Pressure and temperature units are converted automatically. Other units are not converted.

In the following example, the volume in a tank should be measured in liters. The maximum volume of 1 000 l (264 gal) corresponds to a pressure of 450 mbar (6.75 psi).

The minimum volume of 0 liters corresponds to a pressure of 50 mbar (0.75 psi).

Prerequisites:

- Measured variable in direct proportion to the pressure
- Due to the orientation of the measuring device, there may be pressure shifts in the measured value (when the vessel is empty or partly filled, the measured value is not zero)

Perform position adjustment if necessary

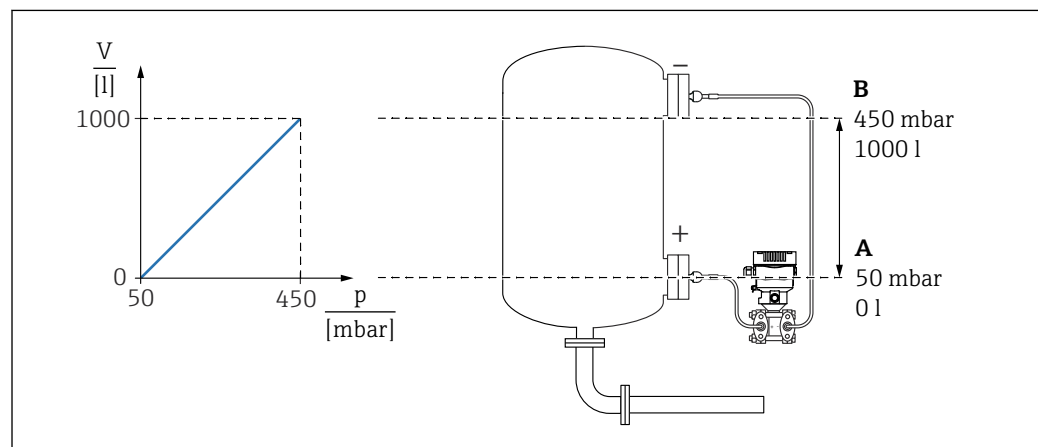

A0039100

A "Pressure value 1" parameter and "Scaled variable value 1" parameter

B "Pressure value 2" parameter and "Scaled variable value 2" parameter

i The pressure present is displayed in the operating tool on the same settings page in the "Pressure" field.

1. Enter the pressure value for the lower calibration point via the **Pressure value 1** parameter: 50 mbar (0.75 psi)
 - ↳ Menu path: Application → Sensor → Scaled variable → Pressure value 1
2. Enter the volume value for the lower calibration point via the **Scaled variable value 1** parameter: 0 l (0 gal)
 - ↳ Menu path: Application → Sensor → Scaled variable → Scaled variable value 1
3. Enter the pressure value for the upper calibration point via the **Pressure value 2** parameter: 450 mbar (6.75 psi)
 - ↳ Menu path: Application → Sensor → Scaled variable → Pressure value 2
4. Enter the volume value for the upper calibration point via the **Scaled variable value 2** parameter: 1 000 l (264 gal)
 - ↳ Menu path: Application → Sensor → Scaled variable → Scaled variable value 2

Result: The measuring range is set for 0 to 1 000 l (0 to 264 gal). Only the **Scaled variable value 1** parameter and **Scaled variable value 2** parameter are set with this setting. This setting has no effect on the current output.

Low flow cut off (square root extraction)

Measured value suppression can be set in the lower measuring range with the **Low cutoff** parameter.

Prerequisites:

- Measured variable with square root extraction in relation to pressure
- In the **Output current transfer function** parameter, set the **Square** option.
Menu path: Application → Sensor → Sensor configuration → Output current transfer function
- Enter the switch-on point for low flow cut off in the **Low cutoff** parameter (default 5 %)
Menu path: Application → Sensor → Sensor configuration → Low cutoff

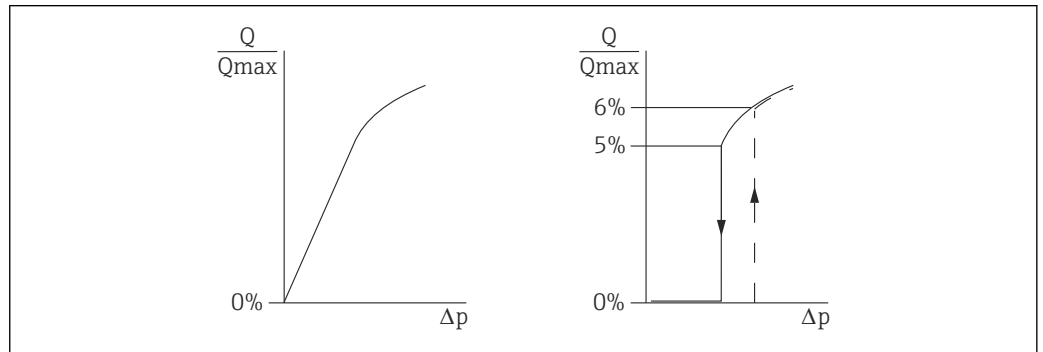

A0025191

- The hysteresis between the switch-on point and the switch-off point is always 1 % of the maximum flow value
- If a switch-on point of 0 % is entered, low flow cut off is deactivated

In the **Assign PV** parameter, the **Pressure** option must be set (factory setting)

Menu path: Application → Sensor → Scaled variable → Assign PV

The set unit is also output on the fieldbus.

9.8 "Simulation" submenu

Pressure, current and alarm/warning can be simulated with the **Simulation** submenu.

Menu path: Diagnostics → Simulation

9.9 Protecting settings from unauthorized access

9.9.1 Hardware locking or unlocking

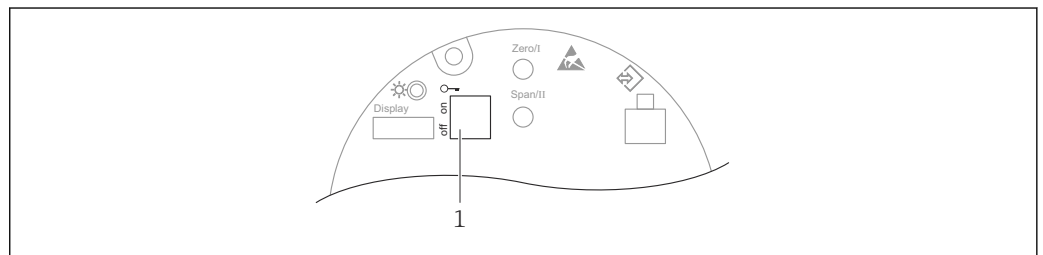

A0043441

DIP switch 1 on the electronic insert is used to lock or unlock operation.

If operation is locked by means of the DIP switch, you can only unlock operation again by means of DIP switch 1.

If operation is locked by means of the operating menu, you can only unlock operation again by means of the operating menu.

If operation is locked via the DIP switch, the key symbol  appears on the local display.

9.9.2 Display operation - locking or unlocking

The  key must be pressed for at least 2 seconds in order to lock or unlock the optical keys. Display operation can be locked or unlocked in the dialog that appears.

Display operation locks automatically (except in the SIL wizard):

- After 1 minute on the main page if no key has been pressed
- After 10 minutes within the operating menu if no key has been pressed

9.9.3 Software locking or unlocking

 If operation is locked by means of the DIP switch, you can only unlock operation again by means of the DIP switch.

Locking via password in FieldCare / DeviceCare / SmartBlue

Access to the configuration of the measuring device can be locked by assigning a password. When the device is delivered from the factory, the user role is set to the **Maintenance** option. The measuring device can be fully configured with the **Maintenance** option user role. Afterwards, access to the configuration can be locked by assigning a password. The **Maintenance** option switches to the **Operator** option as a result of the locking. The configuration can be accessed by entering the password.

The password is defined under:

System menu **User management** submenu

The user role is changed from the **Maintenance** option to the **Operator** option under:

System → User management

Deactivating the lock via FieldCare / DeviceCare / SmartBlue

After entering the password, you can enable the configuration of the measuring device as an **Operator** option with the password. The user role then changes to **Maintenance** option.

If necessary, the password can be deleted in the **User management** submenu: System → User management

10 Operation

10.1 Reading the device locking status

Display of active write protection:

- In the **Locking status** parameter
 - Menu path of local display: at the top operating level
 - Menu path of operating tool: System → Device management
- In the operating tool (FieldCare/DeviceCare) in the DTM header

10.2 Reading measured values

With the **Measured values** submenu, it is possible to read all the measured values.

Navigation

"Application" menu → Measured values

10.3 Adapting the measuring device to the process conditions

The following are available for this purpose:

- Basic settings using the **Guidance** menu
- Advanced settings using the **Diagnostics** menu, **Application** menu and **System** menu

10.3.1 Sensor calibration ²⁾

In the course of their life cycle, pressure sensors **can** deviate, or drift, ³⁾ from the original pressure characteristic curve. This deviation is caused by physical factors and can be corrected with a sensor calibration.

Absolute pressure sensors cannot be recalibrated.

Perform the sensor calibration. Adhere to the sequence indicated!

1. Apply the lower pressure value to the device.
2. Enter the value for the **Lower sensor trim** parameter. Application → Sensor → Sensor calibration → Lower sensor trim
 - ↳ The value entered causes a parallel shift of the pressure characteristic in relation to the current calibration.
3. Apply the upper pressure value to the device.
4. Enter the value for the **Upper sensor trim** parameter. Application → Sensor → Sensor calibration → Upper sensor trim
 - ↳ The value entered causes a change in the slope or a parallel shift of the current calibration curve.

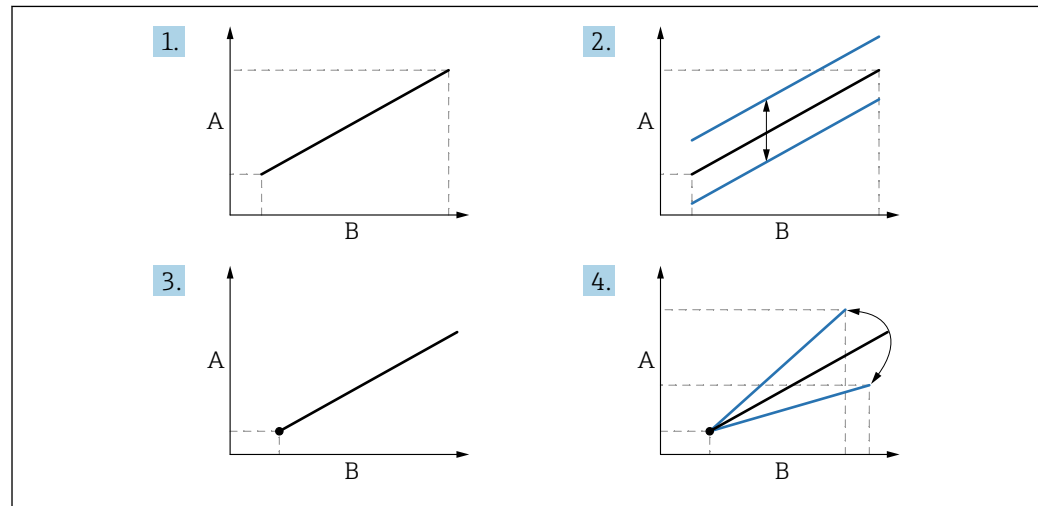

A0045038

A Pressure display
 B Pressure input

2) Not possible with display.

3) Deviations caused by physical factors are also known as "Sensor drift".

11 Diagnostic and troubleshooting

11.1 General troubleshooting

11.1.1 General errors

Device does not respond

- Possible cause: Supply voltage does not match the specification on the nameplate
Remedial action: Apply the correct voltage
- Possible cause: The polarity of the supply voltage is wrong
Remedial action: Correct the polarity
- Possible cause: The cables do not contact the terminals properly
Remedial action: Check the electrical contact between cables and correct if necessary
- Possible cause: Load resistance too high
Remedial action: Increase the supply voltage to reach the minimum terminal voltage

Display is blank

- Possible cause: Graphic display is set too bright or too dark
Remedial action: Increase or reduce the contrast with the **Contrast display** parameter
Navigation path: System → Display → Contrast display
- Possible cause: The plug of the display cable is not connected correctly
Remedial action: Connect the plug correctly
- Possible cause: Display is defective
Remedial action: Replace the display

No background lighting on the graphic display

Possible cause: The electric current and voltage are not correct.

Remedial action: Increase the supply voltage.

"Communication error" is indicated on the display when the device is started or the display is connected

- Possible cause: Electromagnetic interference influence
Remedial action: Check grounding of the device
- Possible cause: Defective cable connection or display plug
Remedial action: Replace the display

HART communication not working

- Possible cause: Communication resistor missing or incorrectly installed
Remedial action: Install the communication resistor (250 Ω) correctly
- Possible cause: Commubox is connected incorrectly
Remedial action: Connect Commubox correctly

Communication via CDI interface not working

Possible cause: Wrong setting of the COM port on the computer

Remedial action: Check the setting of the COM port on the computer and correct it if necessary

Device measures incorrectly

Possible cause: Parametrization error

Remedial action: Check and correct the parameter configuration

No communication with device via SmartBlue

- Possible cause: No Bluetooth connection available
Remedial action: Enable Bluetooth function on smartphone, tablet and measuring device
- Possible cause: The device is already connected with another smartphone/tablet
Remedial action: Disconnect the device from the other smartphone/tablet
- Bluetooth connection disrupted by ambient conditions (e.g. walls/tanks)
Remedial action: Establish direct line-of-sight connection
- Display does not have Bluetooth

Login via SmartBlue not possible

- Possible cause: Device is being put into operation for the first time
Remedial action: Enter the user name ("admin") and the password (device serial number)
- Possible cause: The electric current and voltage are not correct.
Remedial action: Increase the supply voltage.

Device cannot be operated via SmartBlue

- Possible cause: Incorrect password entered
Remedial action: Enter the correct password
- Possible cause: Forgotten password
Remedial action: Contact Endress+Hauser Service (www.addresses.endress.com)
- Possible cause: **Operator** option does not have authorization
Remedial action: Change to **Maintenance** option

11.1.2 Error - SmartBlue operation with Bluetooth®**Device is not visible in the live list**

- Possible cause: No Bluetooth connection available
Remedial action: Enable Bluetooth in the field device via display or software tool and/or in the smartphone/tablet
- Possible cause: Bluetooth signal outside range
Remedial action: Reduce distance between field device and smartphone/tablet
The connection range is up to 25 m (82 ft).
Operating radius with intervisibility 10 m (33 ft)
- Possible cause: Geolocation is not enabled on Android devices or not permitted for the SmartBlue App
Remedial action: Enable/disable geolocation service on Android device for the SmartBlue App

Device appears in the live list but a connection cannot be established

- Possible cause: The device is already connected with another smartphone/tablet via Bluetooth
Only one point-to-point connection is permitted
Remedial action: Disconnect the smartphone/tablet from the device
- Possible cause: Incorrect user name and password
Remedial action: The standard user name is "admin" and the password is the device serial number indicated on the device nameplate (only if the password was not changed by the user beforehand)
If the password has been forgotten, contact Endress+Hauser Service (www.addresses.endress.com)

Connection via SmartBlue not possible

Possible cause: Incorrect password entered

Remedial action: Enter the correct password, paying attention to lower/upper case

Connection via SmartBlue not possible

Possible cause: Forgotten password

Remedial action: Contact Endress+Hauser Service (www.addresses.endress.com)

11.1.3 Additional tests

If no clear cause of the error can be identified or the source of the problem can be both the device and the application, the following additional tests can be performed:

1. Check the digital pressure value (display, HART, etc.).
2. Check that the device concerned is functioning correctly. Replace the device if the digital value does not correspond to the expected pressure value.
3. Switch on simulation and check the current output. Replace the main electronics if the current output does not correspond to the simulated value.

11.1.4 Response of current output to errors

The response of the current output to errors is defined by the **Failure behavior current output** parameter.

Parameter overview with brief description

Parameter	Description	Selection / User entry
Failure behavior current output	Defines which current the output assumes in the case of an error. Min: < 3.6 mA Max: >21.5 mA	<ul style="list-style-type: none">■ Min.■ Max.
Failure current	Enter current output value in alarm condition.	21.5 to 23 mA

11.2 Diagnostic information on local display

11.2.1 Diagnostic message

Measured value display and diagnostic message in alarm condition

Faults detected by the self-monitoring system of the measuring device are displayed as a diagnostic message in alternation with the unit.

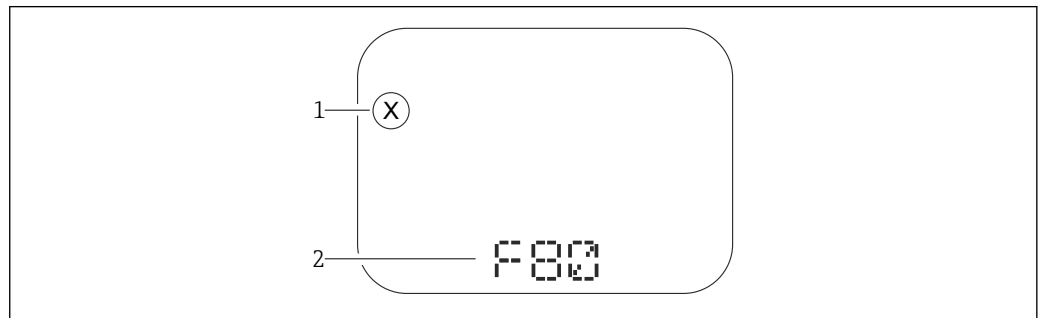

A0043759

- 1 Status signal
- 2 Status symbol with diagnostic event

Faults detected by the self-monitoring system of the measuring device are displayed as a diagnostic message in alternation with the measured value display.

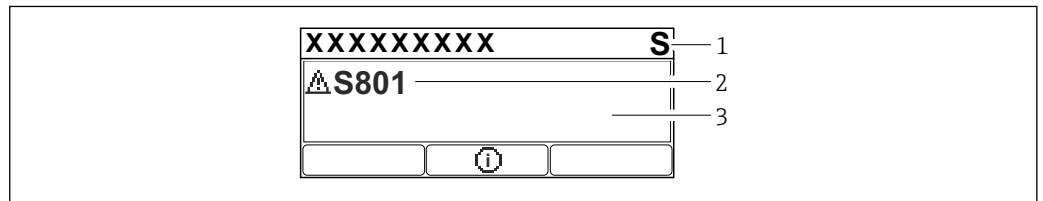

A0043103

- 1 Status signal
- 2 Status symbol with diagnostic event
- 3 Event text

Status signals

F

"Failure (F)" option

A device error has occurred. The measured value is no longer valid.

C

"Function check (C)" option

The device is in the service mode (e.g. during a simulation).

S

"Out of specification (S)" option

The device is being operated:

- Outside its technical specifications (e.g. during warmup or cleaning process)
- Outside the configuration carried out by the user (e.g. level outside configured span)

M

"Maintenance required (M)" option

Maintenance required. The measured value is still valid.

Diagnostic event and event text

The fault can be identified by means of the diagnostic event. The event text helps you by providing information about the fault. In addition, the corresponding status symbol is displayed before the diagnostic event.

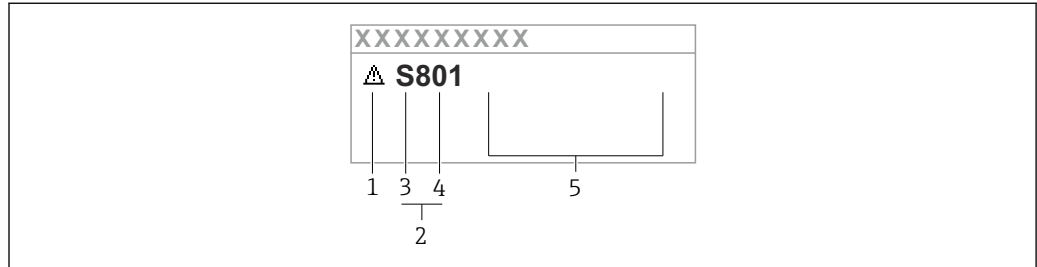

A0038013

- 1 Status symbol
- 2 Diagnostic event
- 3 Status signal
- 4 Event number
- 5 Event text

If two or more diagnostic events are pending simultaneously, only the diagnostic message with the highest priority is shown.

"Active diagnostics" parameter

Key

Opens the message about the remedial measures.

Key

Acknowledge warnings.

Key

Back to operating menu.

11.3 Diagnostic event in the operating tool

If a diagnostic event is present in the device, the status signal appears in the top left status area of the operating tool along with the corresponding symbol for the event level in accordance with NAMUR NE 107:

- Failure (F)
- Function check (C)
- Out of specification (S)
- Maintenance required (M)

Click the status signal to see the detailed status signal.

The diagnostic events and remedial measures can be printed out in the **Diagnostic list** submenu.

11.4 Adapting the diagnostic information

The event level can be configured:

Menu path: Diagnostics → Diagnostic settings → Configuration

11.5 Queued diagnostic messages

The display alternates between the queued diagnostic messages and the measured value.

Queued diagnostic messages can also be displayed in the **Active diagnostics** parameter.

Menu path: Diagnostics → Active diagnostics

11.6 Diagnostic list

All the diagnostic messages currently queued can be displayed in the **Diagnostic list** submenu.

Navigation path

Diagnostics → Diagnostic list

11.6.1 List of diagnostic events

Diagnostic number	Short text	Remedy instructions	Status signal [from the factory]	Diagnostic behavior [from the factory]
Diagnostic of sensor				
062	Sensor connection faulty	Check sensor connection	F	Alarm
081	Sensor initialization faulty	1. Restart device 2. Contact service	F	Alarm
100	Sensor error	1. Restart the device 2. Contact Endress+Hauser Service	F	Alarm
101	Sensor temperature	1. Check process temperature 2. Check ambient temperature	F	Alarm
102	Sensor incompatible error	1. Restart device 2. Contact service	F	Alarm
Diagnostic of electronic				
242	Firmware incompatible	1. Check software 2. Flash or change main electronic module	F	Alarm
252	Module incompatible	1. Check if correct electronic modul is plugged 2. Replace electronic module	F	Alarm
263	Incompatibility detected	Check electronic module type	M	Warning
270	Main electronics defective	Replace main electronics	F	Alarm
272	Main electronics faulty	1. Restart device 2. Contact service	F	Alarm
273	Main electronics defective	1. Transfer data or reset device 2. Contact service	F	Alarm
282	Data storage inconsistent	1. Restart device 2. Contact service	F	Alarm
283	Memory content inconsistent	1. Transfer data or reset device 2. Contact service	F	Alarm
287	Memory content inconsistent	1. Restart device 2. Contact service	M	Warning
311	Electronic failure	Maintenance required! 1. Do not perform reset 2. Contact service	M	Warning
Diagnostic of configuration				
410	Data transfer failed	1. Check connection 2. Retry data transfer	F	Alarm
412	Processing download	Download active, please wait	C	Warning
431	Trim required	Carry out trim	C	Warning
435	Linearization faulty	Check linearization table	F	Alarm
437	Configuration incompatible	1. Restart device 2. Contact service	F	Alarm
438	Dataset different	1. Check data set file 2. Check device configuration 3. Up- and download new configuration	M	Warning
441	Current output out of range	1. Check process 2. Check current output settings	S	Warning

Diagnostic number	Short text	Remedy instructions	Status signal [from the factory]	Diagnostic behavior [from the factory]
484	Failure mode simulation active	Deactivate simulation	C	Alarm
485	Process variable simulation active	Deactivate simulation	C	Warning
491	Current output simulation active	Deactivate simulation	C	Warning
495	Diagnostic event simulation active	Deactivate simulation	C	Warning
500	Process alert pressure	1. Check process pressure 2. Check configuration of process alert	S	Warning ¹⁾
501	Process alert scaled variable	1. Check process conditions 2. Check scaled variable configuration	S	Warning ¹⁾
502	Process alert temperature	1. Check process temperature 2. Check configuration of process alert	S	Warning ¹⁾
503	Zero adjustment	1. Check measuring range 2. Check position adjustment	M	Warning
Diagnostic of process				
801	Supply voltage too low	Increase supply voltage	F	Alarm
802	Supply voltage too high	Decrease supply voltage	S	Warning
805	Loop current faulty	1. Check wiring 2. Replace electronics	F	Alarm
806	Loop diagnostics	1. Check supply voltage 2. Check wiring and terminals	M	Warning ¹⁾
807	No Baseline due to insuf. volt. at 20 mA	Increase supply voltage	M	Warning
822	Sensor temperature out of range	1. Check process temperature 2. Check ambient temperature	S	Warning ¹⁾
825	Operating temperature	1. Check ambient temperature 2. Check process temperature	S	Warning
841	Operating range	1. Check the process pressure 2. Check the sensor range	S	Warning ¹⁾
900	High signal noise detected	1. Check impulse line 2. Check valve position 3. Check process	M	Warning ¹⁾
901	Low signal noise detected	1. Check impulse line 2. Check valve position 3. Check process	M	Warning ¹⁾
902	Min signal noise detected	1. Check impulse line 2. Check valve position 3. Check process	M	Warning ¹⁾
906	Out of range signal detected	1. Process Information. No action 2. Rebuild baseline 3. Adapt signal range thresholds	S	Warning ¹⁾

1) Diagnostic behavior can be changed.

11.7 Event logbook

11.7.1 Event history

The **Event list** submenu provides a chronological overview of the event messages that have occurred ⁴⁾.

Navigation path

Diagnostics → Event logbook

A maximum of 100 event messages can be displayed in chronological order.

The event history includes entries for:

- Diagnostic events
- Information events

In addition to the operation time of the event occurrence, each event is also assigned a symbol that indicates whether the event has occurred or has ended:

- Diagnostic event
 - ☺: Occurrence of the event
 - ☹: End of the event
- Information event
 - ☺: Occurrence of the event

11.7.2 Filtering the event logbook

Using filters, you can define which category of event messages is displayed in the **Event list** submenu.

Navigation path

Diagnostics → Event logbook

Filter categories

- All
- Failure (F)
- Function check (C)
- Out of specification (S)
- Maintenance required (M)
- Information

11.7.3 Overview of information events

Info number	Info name
I1000	----- (Device ok)
I1079	Sensor changed
I1089	Power on
I1090	Configuration reset
I1091	Configuration changed
I11074	Device verification active
I1110	Write protection switch changed
I11104	Loop diagnostics
I1151	History reset
I1154	Reset terminal voltage min/max

4) If operating via FieldCare, the event list can be displayed with the "Event List/HistoROM" FieldCare function.

Info number	Info name
I1155	Reset electronics temperature
I1157	Memory error event list
I1256	Display: access status changed
I1264	Safety sequence aborted
I1335	Firmware changed
I1397	Fieldbus: access status changed
I1398	CDI: access status changed
I1440	Main electronic module changed
I1444	Device verification passed
I1445	Device verification failed
I1461	Sensor verification failed
I1512	Download started
I1513	Download finished
I1514	Upload started
I1515	Upload finished
I1551	Assignment error fixed
I1552	Failed: Main electronic verification
I1554	Safety sequence started
I1555	Safety sequence confirmed
I1556	Safety mode off
I1956	Reset

11.8 Resetting the measuring device

11.8.1 Resetting the measuring device via the operating software or display

The device can be reset with the **Device reset** parameter.

Menu path: System → Device management

For details see the "Description of device parameters" document.

11.8.2 Resetting the measuring device via keys on the electronics insert

Press the "Zero" and "Span" keys simultaneously for at least 12 seconds.

11.9 Device information

All the device information is contained in the **Information** submenu.

Menu path: System → Information

For details see the "Description of device parameters" document.

11.10 Firmware history

 The firmware version can explicitly be ordered via the product structure. This makes it possible to ensure the compatibility of the firmware version with an existing or planned system integration.

11.10.1 Version 01.00.zz

Original software

12 Maintenance

12.1 Maintenance tasks

This chapter describes the maintenance of physical device components.

12.1.1 Flushing rings

 By using flushing rings, the process isolating diaphragm can be cleaned without removing the measuring device from the process.

For more information: contact the Endress+Hauser sales office.

12.1.2 Exterior cleaning

Notes on cleaning

- The cleaning agents used should not corrode the surfaces and the seals
- Mechanical damage to the process isolating diaphragm, e.g. due to pointed objects, must be avoided
- Pay attention to the degree of protection of the measuring device

13 Repair

13.1 General notes

13.1.1 Repair concept

Under the Endress+Hauser repair concept, devices have a modular design and repairs can be carried out by Endress+Hauser Service or by properly trained customers.

Spare parts are grouped into logical kits with the associated replacement instructions.

For more information on service and spare parts contact Endress+Hauser Service.

13.1.2 Repairs to Ex- or SIL-certified devices

WARNING

Limitation of electrical safety due to incorrect repair!

Risk of explosion!

- ▶ Only specialist personnel or Endress+Hauser-Service can carry out repairs to Ex certified devices.
- ▶ Relevant standards and national regulations as well as safety instructions (XA) and certificates must be observed.
- ▶ Only genuine Endress+Hauser spare parts may be used.
- ▶ When ordering spare parts, please check the device designation on the nameplate. Only identical parts may be used as replacements.
- ▶ Carry out repairs according to the instructions. Following a repair, the device must fulfill the requirements of the individual tests specified for that device.
- ▶ A certified device may be converted to another certified device version by Endress +Hauser Service only.
- ▶ All repairs and modifications must be documented.

13.2 Spare parts

- Some replaceable measuring device components are identified by means of a spare part nameplate. This contains information about the spare part.
- All the spare parts for the measuring device, along with the order code, are listed and can be ordered in the *Device Viewer* (www.endress.com/deviceviewer). If available, users can also download the associated Installation Instructions.

 Measuring device serial number:

- Located on the device and spare part nameplate.
- Can be read out via the device software.

13.3 Replacement

CAUTION

Data upload/download is not permitted if the device is used for safety-related applications.

- ▶ After an entire device or an electronics module has been replaced, the parameters can be downloaded to the device again via the communication interface. For this, the data must have been uploaded to the PC beforehand using the "FieldCare/DeviceCare" software.

13.3.1 HistoROM

It is not necessary to perform a new device calibration after replacing the display or transmitter electronics. The parameters are saved in the HistoROM.

 After replacing the transmitter electronics, remove the HistoROM and insert it into the new replacement part.

13.4 Return

The measuring device must be returned in the event of a factory calibration, or if the wrong device has been ordered or delivered.

As an ISO-certified company and due to legal requirements,

Endress+Hauser is required to follow certain procedures when handling returned products that have been in contact with a medium. To ensure swift, safe and professional device returns, please read the return procedures and conditions on the Endress+Hauser website at www.services.endress.com/return-material

- ▶ Select country.
 - ↳ The website of the responsible sales organization opens with all of the relevant information relating to returns.
- 1. If the desired country is not listed:
 - Click on the "Choose your location" link.
 - ↳ An overview of Endress+Hauser sales organizations and representatives opens.
- 2. Contact the Endress+Hauser sales organization responsible for your area.

13.5 Disposal



If required by the Directive 2012/19/EU on waste electrical and electronic equipment (WEEE), the product is marked with the depicted symbol in order to minimize the disposal of WEEE as unsorted municipal waste. Do not dispose of products bearing this marking as unsorted municipal waste. Instead, return them to Endress+Hauser for disposal under the applicable conditions.

14 Accessories

14.1 Device-specific accessories

14.1.1 Mechanical accessories

- Mounting bracket for housing
- Mounting bracket for manifolds
- Manifolds
- Oval flange adapter
- Calibration adapter 5/16"-24 UNF, to screw into vent valves
- Weather protection covers

 For technical data (e.g. materials, dimensions or order numbers), see the accessory document SD01553P.

14.1.2 Plug connectors

- Plug connector M12 90 deg, IP67 5m cable, union nut, Cu Sn/Ni
- Plug connector M12, IP67 union nut, Cu Sn/Ni
- Plug connector M12, 90 deg IP67 union nut, Cu Sn/Ni

 The IP protection classes are only maintained if the dummy cap is used or the cable is connected.

14.1.3 Weld-in accessory

 For details, refer to TI00426F/00/EN "Weld-in adapters, process adapters and flanges".

14.2 Device Viewer

All the accessories for the measuring device, along with the order code, are listed in the *Device Viewer* (www.endress.com/deviceviewer).

15 Technical data

15.1 Output

Output signal	<p>Current output</p> <p>4 to 20 mA with superimposed digital communication protocol HART, 2-wire</p> <p>The current output offers a choice of three different operating modes:</p> <ul style="list-style-type: none"> ■ 4.0 to 20.5 mA ■ NAMUR NE 43: 3.8 to 20.5 mA (factory setting) ■ US mode: 3.9 to 20.8 mA
---------------	---

Signal on alarm	<p>Signal on alarm in accordance with NAMUR recommendation NE 43.</p> <p>Options:</p> <ul style="list-style-type: none"> ■ Max alarm: can be set from 21.5 to 23 mA ■ Min. alarm: < 3.6 mA (factory setting)
-----------------	---

Load	4 to 20 mA HART
------	------------------------

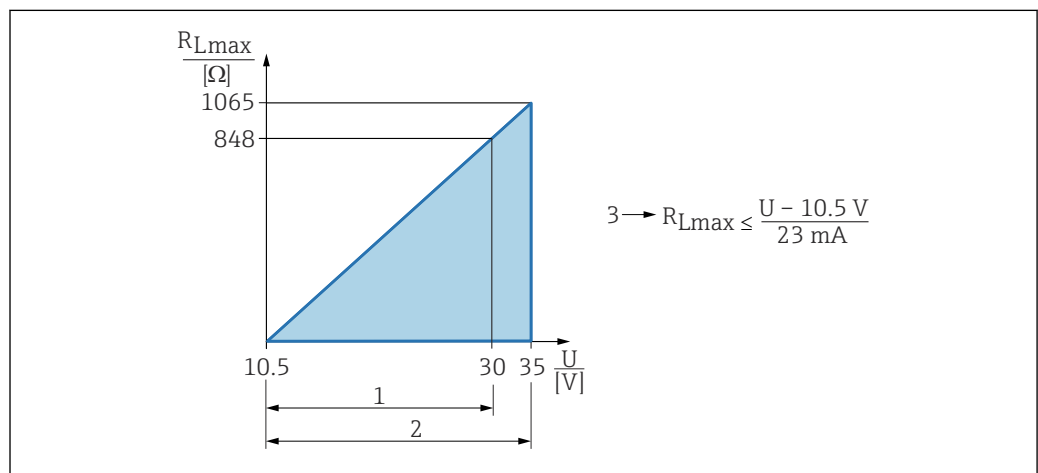

- 1 Power supply 10.5 to 30 VDC Ex i
- 2 Power supply 10.5 to 35 VDC, for other types of protection and for non-certified device versions
- 3 R_{Lmax} maximum load resistance
- U Supply voltage

i Operation via handheld terminal or PC with operating program: take minimum communication resistance of 250 Ω into consideration.

Damping	<p>A damping affects all outputs (output signal, display). Damping can be enabled as follows:</p> <ul style="list-style-type: none"> ■ Via the onsite display, Bluetooth, handheld terminal or PC with operating program, continuous from 0 to 999 seconds ■ Factory setting: 1 s
---------	---

Ex connection data	<p>See the separate technical documentation (Safety Instructions (XA)) on www.endress.com/download.</p>
--------------------	---

Linearization	The device's linearization function allows the user to convert the measured value to any units of height or volume. User-defined linearization tables of up to 32 value pairs can be entered if necessary.
Flow measurement with Deltabar and differential pressure sensor	<p>Low flow cut off parameter: When the Low flow cut off parameter is activated, small flows which can lead to large fluctuations in the measured value are suppressed.</p> <p>The Low flow cut off parameter is set to 5% by default when the Output current transfer function parameter is set to Square root option.</p>

Protocol-specific data

HART

- Manufacturer ID: 17 (0x11{hex})
- Device type ID: 0x1131
- Device revision: 1
- HART specification: 7
- DD revision: 1
- Device description files (DTM, DD) information and files at:
 - www.endress.com
 - www.fieldcommgroup.org
- HART load: min. 250 Ohm

HART device variables (preset at the factory)

The following measured values are assigned to the device variables at the factory:

Device variable	Measured value
Primary variable (PV) ¹⁾	Pressure ²⁾
Secondary variable (SV)	Sensor temperature
Tertiary variable (TV)	Electronics temperature
Quaternary variable (QV)	Sensor pressure ³⁾

- 1) The PV is always applied to the current output.
- 2) The pressure is the calculated signal after damping and position adjustment.
- 3) The sensor pressure is the raw sensor signal before damping and position adjustment.

 The assignment of the measured values to the device variables can be changed in the following submenu:
Application → HART output → HART output

 In a HART Multidrop loop, only one device may use the analog current value for signal transmission. For all other devices in the "**Loop current mode**" parameter, select the **Disable** option.

Choice of HART device variables

- **Pressure** option (after position correction and damping)
- Scaled variable
- Sensor temperature
- **Sensor pressure** option Sensor Pressure is the raw signal from sensor before damping and position adjustment.
- Electronics temperature
- **Terminal current** option The terminal current is the read-back current on terminal block. Visibility depends on order options or device settings
- **Terminal voltage 1** option Visibility depends on order options or device settings
- **Noise of pressure signal** option and **Median of pressure signal** option Visibility depends on order options or device settings
- Percent of range
- **Loop current** option The loop current is the output current set by the applied pressure.

Supported functions

- Burst mode
- Additional transmitter status
- Device locking

Wireless HART data

- Minimum starting voltage: 10.5 V
- Start-up current: >3.6 mA
- Starting time: <5 s
- Minimum operating voltage: 10.5 V
- Multidrop current: 4 mA

15.2 Environment

Ambient temperature range

The following values apply up to a process temperature of +85 °C (+185 °F). At higher process temperatures, the permitted ambient temperature is reduced.

- Without LCD display:
 - Standard: -40 to +85 °C (-40 to +185 °F)
 - Optionally available: -50 to +85 °C (-58 to +185 °F) with restricted operating life and performance
 - Optionally available: -54 to +85 °C (-65 to +185 °F); under -50 °C (-58 °F): Ex d measuring devices can be permanently damaged
- With LCD display: -40 to +85 °C (-40 to +185 °F) with limitations in optical properties such as display speed and contrast. Can be used without limitations up to -20 to +60 °C (-4 to +140 °F)
- Separate housing: -20 to +60 °C (-4 to +140 °F)

Devices with inert oil: minimum process and ambient temperature -20 °C (-4 °F)

Ambient temperature T_a depending on the process temperature T_p

The process connection must be fully insulated for ambient temperatures below -40 °C (-40 °F).

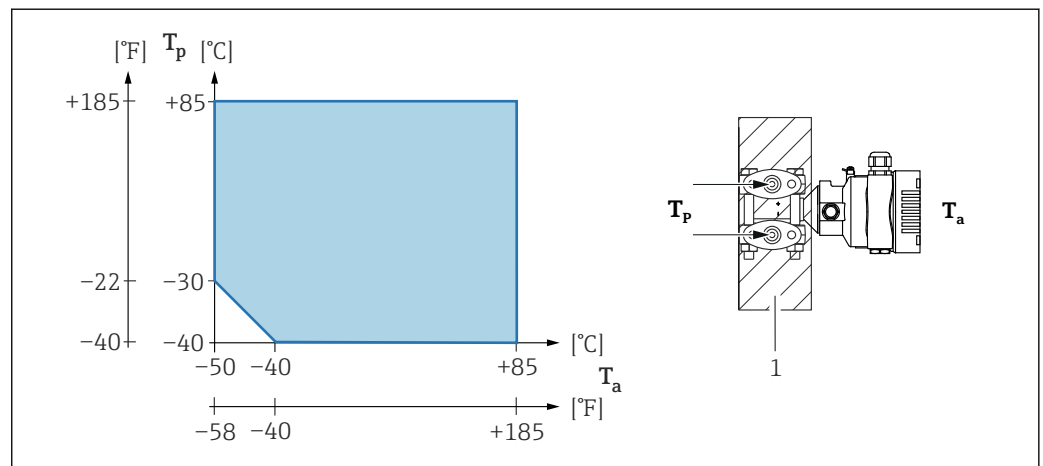

1 Insulation material

Hazardous area

- For measuring devices for use in hazardous areas, see Safety Instructions, Installation or Control Drawing
- Measuring devices with common explosion protection certificates (e.g. ATEX-/ IEC Ex, etc.) can be used in hazardous areas with ambient temperatures from -54 to +85 °C (-65 to +185 °F) (optionally available). The functionality of the explosion protection Ex ia is guaranteed for ambient temperatures to -50 °C (-58 °F) (optionally available).

At temperatures ≤ -50 °C (-58 °F), explosion protection is guaranteed by the housing in the case of flameproof enclosure (Ex d) type of protection. The functionality of the transmitter cannot be fully guaranteed. The Ex ia capability can no longer be guaranteed.

Storage temperature	<ul style="list-style-type: none"> ■ Without LCD display: -40 to +90 °C (-40 to +194 °F) Optional -54 to +85 °C (-65 to +185 °F) ■ Without LCD display: -40 to +90 °C (-40 to +194 °F); optional -50 °C (-58 °F) ■ With LCD display: -40 to +85 °C (-40 to +185 °F) ■ Separate housing: -40 to +60 °C (-40 to +140 °F) <p>With M12 plug, elbowed: -25 to +85 °C (-13 to +185 °F)</p>
Operating altitude	Up to 5 000 m (16 404 ft) above sea level.
Climate class	Class 4K4H (air temperature: -20 to +55 °C (-4 to +131 °F), relative humidity: 4 to 100 %) satisfied as per DIN EN 60721-3-4. Condensation is possible.
Atmosphere	Operation in very corrosive environment Anodic corrosion protection can be ordered as a "mounted accessory".
Degree of protection	Test as per IEC 60529 and NEMA 250-2014

Housing and process connection

IP66/68, TYPE 4X/6P
(IP68: (1.83 mH₂O for 24 h))

Cable entries

- Gland M20, plastic, IP66/68 TYPE 4X/6P
- Gland M20, brass nickel plated, IP66/68 TYPE 4X/6P
- Gland M20, 316L, IP66/68 TYPE 4X/6P
- Thread M20, IP66/68 TYPE 4X/6P
- Thread G1/2, IP66/68 TYPE 4X/6P
If the G1/2 thread is selected, the device is delivered with an M20 thread as standard and a G1/2 adapter is included with the delivery, along with the corresponding documentation
- Thread NPT1/2, IP66/68 TYPE 4X/6P
- Dummy plug transport protection: IP22, TYPE 2
- Plug HAN7D, 90 deg. IP65 NEMA Type 4X
- Plug M12
When housing is closed and connecting cable is plugged in: IP66/67 NEMA Type 4X
When housing is open or connecting cable is not plugged in: IP20, NEMA Type 1

NOTICE

Plug M12 and plug HAN7D: incorrect mounting can invalidate the IP protection class!

- ▶ The degree of protection only applies if the connecting cable used is plugged in and screwed tight.
- ▶ The degree of protection only applies if the connecting cable used is specified according to IP67 NEMA Type 4X.
- ▶ The IP protection classes are only maintained if the dummy cap is used or the cable is connected.

Process connection and process adapter when using the separate housing*FEP cable*

- IP69 (on sensor side)
- IP66 TYPE 4/6P
- IP68 (1.83 mH₂O for 24 h) TYPE 4/6P

PE cable

- IP69 (on sensor side)
- IP66 TYPE 4/6P
- IP68 (1.83 mH₂O for 24 h) TYPE 4/6P

Vibration resistance

Single compartment housing

Measuring range	Sine wave oscillation IEC 61298-3:2008	Shock
10 mbar (0.15 psi) and 30 mbar (0.45 psi) (only up to PN100)	10 Hz to 60 Hz: ±0.21 mm (0.0083 in) 60 Hz to 2000 Hz: 3 g	30 g
0.1 to 250 bar (1.5 to 3 750 psi)	10 Hz to 60 Hz: ±0.35 mm (0.0138 in) 60 Hz to 1000 Hz: 5 g	30 g

Aluminum dual compartment housing

Measuring range	Sine wave oscillation IEC 61298-3:2008	Shock
10 mbar (0.15 psi) and 30 mbar (0.45 psi)	10 Hz to 60 Hz: ±0.21 mm (0.0083 in) 60 Hz to 2000 Hz: 3 g	30 g
0.1 to 250 bar (1.5 to 3 750 psi)	10 Hz to 60 Hz: ±0.35 mm (0.0138 in) 60 Hz to 1000 Hz: 5 g	30 g

Stainless steel dual compartment housing

Measuring range	Sine wave oscillation IEC 61298-3:2008	Shock
10 mbar (0.15 psi) and 30 mbar (0.45 psi) (only up to PN63)	10 Hz to 60 Hz: ±0.15 mm (0.0059 in) 60 Hz to 500 Hz: 1 g	15 g
0.1 to 250 bar (1.5 to 3 750 psi)	10 Hz to 60 Hz: ±0.15 mm (0.0059 in) 60 Hz to 500 Hz: 2 g	15 g

Dual compartment housing, L-shape

Sine wave oscillation IEC 61298-3:2008	Shock
10 Hz to 60 Hz: ±0.21 mm (0.0083 in) 60 Hz to 2000 Hz: 3 g	30 g

Electromagnetic compatibility (EMC)

- Electromagnetic compatibility as per EN 61326 series and NAMUR recommendation EMC (NE21)
- With regard to the safety function (SIL), the requirements of EN 61326-3-x are satisfied
- Maximum deviation with interference influence: < 0.5% of span with full measuring range (TD 1:1)

For more details refer to the EU Declaration of Conformity.

15.3 Process

Process temperature range

NOTICE

The permitted process temperature depends on the process connection, the ambient temperature and the type of approval.

- ▶ All the temperature data in this document must be taken into consideration when selecting the measuring device.

Devices without a manifold

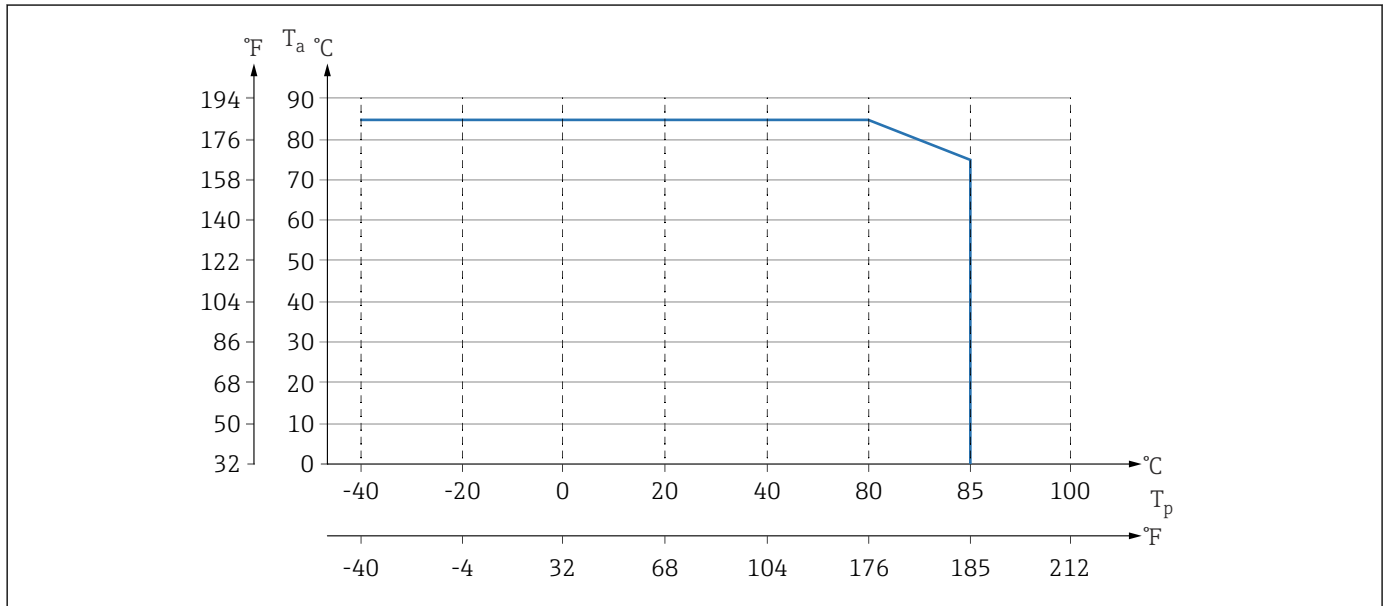

A0043339

8 Values apply for vertical mounting without insulation.

T_p Process temperature

T_a Ambient temperature

Devices with a manifold

The maximum permitted process temperature at the manifold is 110 °C (230 °F).

For process temperatures >85 °C (185 °F)C where non-insulated side flanges are installed horizontally on a valve manifold, a reduced ambient temperature applies (see the following graphic).

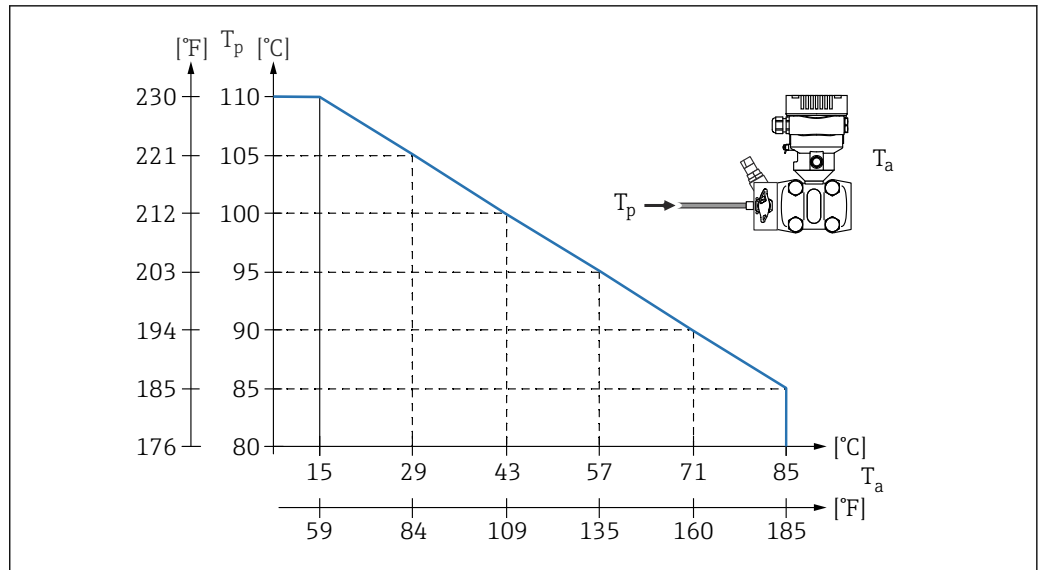

T_a Maximum ambient temperature at the manifold
 T_p Maximum process temperature at the manifold

Oxygen applications (gaseous)

Oxygen and other gases can react explosively to oils, grease and plastics. The following precautions must be taken:

- All components of the plant, such as the measuring devices, must be cleaned according to national requirements.
- Depending on the materials used, a certain maximum temperature and a maximum pressure must not be exceeded for oxygen applications.

Cleaning of the measuring device (not device accessories) is offered as an optional service.

- p_{max}: 80 bar (1 200 psi)
- T_{max} environment: 60 °C (140 °F)

Process temperature range (temperature at transmitter)

Measuring device without a manifold

- -40 to +85 °C (-40 to +185 °F)
 Lower temperatures are optionally available.
- Pay attention to the process temperature range of the seal

Measuring device with a manifold

The maximum permitted process temperature at the manifold is 110 °C (230 °F) (limited by IEC standard).

For process temperatures >85 °C (185 °F) where non-insulated side flanges are installed horizontally on a valve manifold, a reduced ambient temperature applies up to a maximum ambient temperature calculated according to the following formula:

$$T_{\text{Ambient_Temperature_max}} = 85 \text{ °C} - 2.8 \cdot (T_{\text{Process_Temperature}} - 85 \text{ °C})$$

$$T_{\text{Ambient_Temperature_max}} = 185 \text{ °F} - 2.8 \cdot (T_{\text{Process_Temperature}} - 185 \text{ °F})$$

T_{Ambient_Temperature_max} = maximum ambient temperature in °C or °F

T_{Process_Temperature} = process temperature at a manifold in °C or °F

Process temperature range, seals	<ul style="list-style-type: none"> ■ FKM: -20 to +85 °C (-4 to +185 °F) For PN > 160 bar (2 320 psi): T_{\min} -15 °C (+5 °F) ■ PTFE: -40 to +85 °C (-40 to +185 °F) For pressures > 160 bar (2 320 psi): process temperature is limited to -20 °C (-4 °F) ■ FKM, cleaned from oil+grease: -10 to +85 °C (+14 to +185 °F) ■ FKM, cleaned for oxygen service: -10 to +60 °C (+14 to +140 °F) ■ FFKM: <ul style="list-style-type: none"> ■ T -10 to +85 °C (+14 to +185 °F): MWP 87 bar (1 262 psi); OPL 130 bar (1 885 psi) ■ T +25 to +85 °C (+77 to +185 °F): MWP 107 bar (1 552 psi); OPL 160 bar (2 320 psi) ■ EPDM: -40 to +85 °C (-40 to +185 °F) ■ PTFE, cleaned for oxygen applications: -20 to +60 °C (-4 to +140 °F) For pressures > 160 bar (2 320 psi): process temperature is limited to -20 °C (-4 °F)
----------------------------------	---

Process pressure range

Pressure specifications



The maximum pressure for the measuring device depends on the lowest-rated element with regard to pressure (components are: process connection, optional mounted parts or accessories).

- ▶ Only operate the measuring device within the prescribed limits of the components!
- ▶ MWP (maximum working pressure): The MWP is specified on the nameplate. This value refers to a reference temperature of +20 °C (+68 °F) and may be applied to the device for an unlimited time. Note temperature dependence of MWP. For flanges, refer to the following standards for the permitted pressure values at higher temperatures: EN 1092-1 (with regard to their stability/temperature property, the materials 1.4435 and 1.4404 are grouped together under EN 1092-1; the chemical composition of the two materials can be identical.), ASME B 16.5a, JIS B 2220 (the latest version of the standard applies in each case). MWP data that deviate from this are provided in the relevant sections of the Technical Information.
- ▶ The test pressure corresponds to the overpressure limit (OPL) of the overall system. This value refers to a reference temperature of +20 °C (+68 °F).
- ▶ The Pressure Equipment Directive (2014/68/EU) uses the abbreviation "PS". The abbreviation "PS" corresponds to the MWP (maximum working pressure) of the measuring device.
- ▶ In the case of sensor range and process connection combinations where the overpressure limit (OPL) of the process connection is smaller than the nominal value of the sensor, the device is set at the factory, at the very maximum, to the OPL value of the process connection. If the entire sensor range must be used, select a process connection with a higher OPL value (1.5 x PN; MWP = PN).
- ▶ Oxygen applications: do not exceed values for P_{\max} and T_{\max} .

Burst pressure

PN160

- Measuring range: ≤40 bar (580 psi)
- Burst pressure: 690 bar (10 005 psi)
Applies for the process seal materials FKM, PTFE, FFKM, EPDM and for pressure applied on both sides
If the side vent valves option (sv) and the PTFE seal is selected, the burst pressure is 600 bar (8 700 psi)

PN250, PN320, PN420

- Measuring range: ≤40 bar (580 psi)
- Burst pressure: 1 600 bar (23 200 psi)
Applies for the process seal materials FKM, FFKM, EPDM and for pressure applied on both sides
If the side vent valves option (sv) is selected, the burst pressure is 690 bar (10 005 psi)
For the process seal material PTFE (PN250), the burst pressure is 1 250 bar (18 125 psi)

Ultrapure gas applications	Endress+Hauser also offers measuring devices for special applications, such as for ultrapure gas, which are cleaned from oil and grease. No special restrictions regarding the process conditions apply to these measuring devices.
----------------------------	---

Hydrogen applications	A gold-coated metal process membrane offers universal protection against hydrogen diffusion, both in gas applications and in applications with aqueous solutions.
-----------------------	--

Index

A

Access authorization to parameters	
Read access	31
Write access	31
Access code	31
Incorrect input	31

B

Bluetooth® wireless technology	33
--	----

C

CE mark (Declaration of Conformity)	10
Cleaning	67

D

DD	35
Declaration of Conformity	10
Designated use	9
Device description files	35
Device documentation	
Supplementary documentation	8
Device locking, status	53
Device Viewer	68
Diagnostic event	60
In the operating tool	61
Diagnostic events	59
Diagnostic list	61
Diagnostic message	59
Diagnostics	
Symbols	59
Display values	
For locking status	53
Disposal	70

E

Event history	64
Event list	64
Event text	60
Exterior cleaning	67

F

Filtering the event logbook	64
FV (HART variable)	35

H

HART integration	35
HART protocol	38
HART variables	35

L

Local display	
see Diagnostic message	
see In alarm condition	

M

Maintenance	67
-----------------------	----

N

Nameplates	13
----------------------	----

O

Operating elements	
Diagnostic message	60
Operation	53
Operational safety	9

P

Product safety	10
PV (HART variable)	35

R

Read access	31
Reading measured values	53
Repair concept	68
Requirements concerning the staff	9

S

Safety instructions	
Basic	9
Service interface (CDI)	38
Settings	
Adapting the measuring device to the process	
conditions	53
Spare parts	68
Nameplate	68
Status signals	59
Submenu	
Event list	64
Measured values	53
SV (HART variable)	35

T

Troubleshooting	55
Turning the display module	22
TV (HART variable)	35

U

Use of the measuring device	
see Designated use	
Using measuring devices	
Borderline cases	9
Incorrect use	9

W

Workplace safety	9
Write access	31



71521426

www.addresses.endress.com
