

Technical Information

Liquicap M

FMI52

Capacitive



Continuous level measurement for liquids

Application

The device is independent of the dielectric constant (DC) as of a liquid conductivity of 100 $\mu\text{S}/\text{cm}$ and allows measurement of various liquids without the need for recalibration.

- Process connections: Flanges and threads
- Process pressure: Vacuum to +100 bar (+1 450 psi)
- Measuring range: 0.42 to 10 m (1.38 to 33 ft)
- Temperature: -80 to +200 °C (-112 to +392 °F)
- International explosion protection certificates, overfill prevention WHG, SIL, hygienic certificates, marine approvals

Your benefits

- Use also in safety systems requiring functional safety to SIL2 in accordance with IEC 61508
- Reliable and universal application thanks to a wide range of certificates and approvals
- No calibration necessary (factory preconfiguration). No calibration necessary for media with a conductivity of 100 $\mu\text{S}/\text{cm}$ and higher
- Material in contact with the process made of corrosion-resistant material, FDA-listed materials
- Menu-guided local configuration via plain text display (optional)
- Two-stage overvoltage protection

Table of contents

About this document	3	Mechanical construction	26
Document conventions	3	Design dimensions	26
Function and system design	5	Weight	40
Measuring principle	5	Measuring rope specifications	40
Measuring system	6	Materials	40
Input	8	Operability	41
Measured variable	8	Operating concept	41
Measuring range	8	Local operation	41
Measuring condition	8	Local display	42
Output	9	Remote operation	42
Output signal	9	Certificates and approvals	43
Signal on alarm	9	CE mark	43
Linearization	9	RoHS	43
Power supply	10	RCM-Tick marking	43
Terminal assignment	10	Ex approval	43
Connector	11	Hygienic compatibility	43
Supply voltage	11	EAC conformity	44
Power consumption	11	Other standards and guidelines	44
Current consumption	11	CRN approval	44
Cable entries	12	Additional approvals	44
Performance characteristics	12	Pressure Equipment Directive 2014/68/EU	44
Reference operating conditions	12	Ordering information	45
Maximum measured error	12	Accessories	45
Influence of ambient temperature	12	Protective cover	45
Influence of process pressure	12	Commubox FXA195 HART	45
Switch-on behavior	12	Surge arresters	45
Measured value reaction time	13	Weld-in adapter	45
Response time	13	Documentation	46
Accuracy of factory calibration	13	Technical Information	46
Resolution	14	Operating Instructions	46
Installation	15	Certificates	46
Rope probes	15		
Probe with separate housing	17		
Environment	19		
Ambient temperature range	19		
Storage and transport	19		
Climate class	19		
Vibration resistance	19		
Shock resistance	19		
Cleaning	19		
Degree of protection	19		
Electromagnetic compatibility (EMC)	20		
Process	21		
Process temperature range	21		
Process pressure limits	22		
Pressure and temperature derating	23		
Conductivity	25		

About this document

Document conventions

Safety symbols

DANGER

This symbol alerts you to a dangerous situation. Failure to avoid this situation will result in serious or fatal injury.

WARNING

This symbol alerts you to a dangerous situation. Failure to avoid this situation can result in serious or fatal injury.

CAUTION

This symbol alerts you to a dangerous situation. Failure to avoid this situation can result in minor or medium injury.

NOTICE

This symbol contains information on procedures and other facts which do not result in personal injury.

Electrical symbols



Alternating current



Direct current and alternating current



Direct current



Ground connection

A grounded terminal which, as far as the operator is concerned, is grounded via a grounding system.

Protective earth (PE)

Ground terminals that must be connected to ground prior to establishing any other connections.

The ground terminals are located on the interior and exterior of the device:

- Interior ground terminal: protective earth is connected to the mains supply.
- Exterior ground terminal: device is connected to the plant grounding system.

Tool symbols



Phillips head screwdriver



Flat blade screwdriver



Torx screwdriver



Allen key



Open-ended wrench

Symbols for certain types of information and graphics

Permitted

Procedures, processes or actions that are permitted

Preferred

Procedures, processes or actions that are preferred

Forbidden

Procedures, processes or actions that are forbidden

Tip

Indicates additional information



Reference to documentation



Reference to page



Reference to graphic



Notice or individual step to be observed

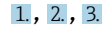

Series of steps



Result of a step



Help in the event of a problem



Visual inspection



Operation via operating tool



Write-protected parameter

1, 2, 3, ...

Item numbers

A, B, C, ...

Views



Hazardous area

Indicates the hazardous area



Safe area (non-hazardous area)

Indicates the non-hazardous area



Safety instructions

Observe the safety instructions contained in the associated Operating Instructions



Temperature resistance of the connection cables

Specifies the minimum value of the temperature resistance of the connection cables

Function and system design

Measuring principle

The principle of capacitance level measurement is based on the change in capacitance of the capacitor due to the change in the level. The probe and container wall made of conductive material form an electric capacitor.

When the probe is in the air, a certain low initial capacitance is measured. When the container is filled, the capacitance increases the more the probe is covered. As of conductivity of $100 \mu\text{S}/\text{cm}$, the measurement is independent of the value for the dielectric constant (DC) of the liquid. As a result, fluctuations in the DC value do not affect the measured value display. Furthermore, the system also prevents the effect of medium buildup or condensate near the process connection for probes with an inactive length.

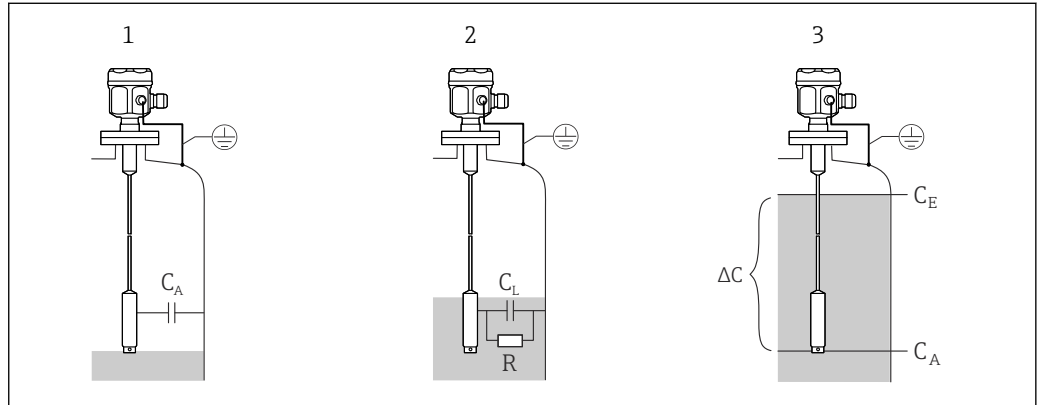

A0040663

- 1 The probe in the air
- 2 The probe covered by the liquid
- 3 The probe fully covered by the liquid
- R Conductivity of the liquid
- C_L Capacitance of the liquid
- C_A Initial capacitance when the probe is not covered
- C_E Final capacitance when the probe is covered
- ΔC Change in capacitance

Function

The selected electronic insert of the probe (e.g. FEI50H HART) converts the measured change in capacitance of the liquid to a signal that is proportional to the level.

Phase-selective measurement

The evaluation of the container capacitance works along the principle of phase-selective measurement. In this process, the amount of alternating current and the phase shift between the voltage and current is measured. With these two characteristic quantities, the capacitance idle current can be calculated by the medium capacitor and the real current by the medium resistance. Conductive buildup stuck to the probe rope acts like additional medium resistance and causes an error in measurement. As the size of the medium resistance can be determined with phase-selective measurement, the system compensates for the buildup on the probe.

Interface

A prior adjustment also ensures a certain and definite measured value even if the emulsion layer is of varying thickness. In this process, the average value of the emulsion film is always measured. The adjustment values for empty and full adjustment can be calculated with the FieldCare operating program from Endress+Hauser.

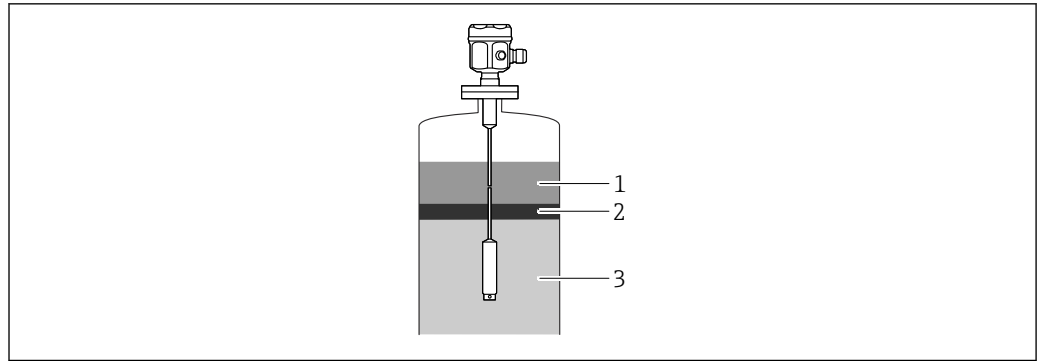

A0040615

- 1 Nonconductive medium $< 1 \mu\text{S}/\text{cm}$, $\text{DC} < 5$
- 2 Emulsion
- 3 Conductive medium $\geq 100 \mu\text{S}/\text{cm}$

Measuring system

4 to 20 mA output with HART protocol (FEI50H)

The complete measuring system consists of:

- the capacitance Liquicap M FMI52 level probe
- the FEI50H electronic insert
- the transmitter power supply unit

i DC voltage must be supplied to the electronic insert. The twin-core feeder is also used for HART protocol signal transmission.

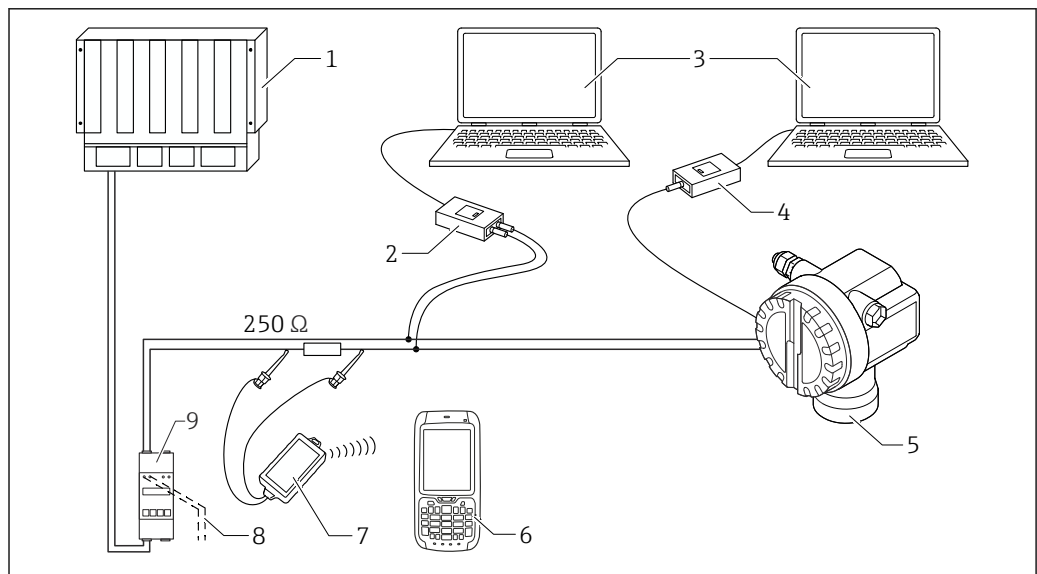

A0038653

- 1 PLC
- 2 Commubox FXA195
- 3 Computer with operating tool FieldCare
- 4 Commubox FXA219
- 5 Probe with FEI50H electronic insert
- 6 Field Xpert
- 7 VIATOR Bluetooth modem with connecting cable
- 8 Output to FXA195
- 9 Transmitter power supply unit RN221N

Local operation:

- Standard
 - using keys and switches on the electronic insert
- Optional
 - using display and operating module

Remote operation:

- with HART
- with a personal computer, Commubox FXA195, and the operating program FieldCare

i FieldCare is a graphic operating program and is used to support commissioning, data backup, signal analysis and documentation of the measuring point.

PFM output (FEI57C)

The complete measuring system consists of:

- the capacitance Liquicap M FMI52 level probe
- the FEI57C electronic insert
- a transmitter power supply unit

i The twin-core feeder is also used for PFM signal transmission.

In combination with a power supply unit, the FEI57C will only run in a 1-channel-mode and without an automatic alignment correction.

For FEI57C a transmitter power supply unit is not available anymore (retrofit device). For new installations FMI52 with FEI50H is recommended.

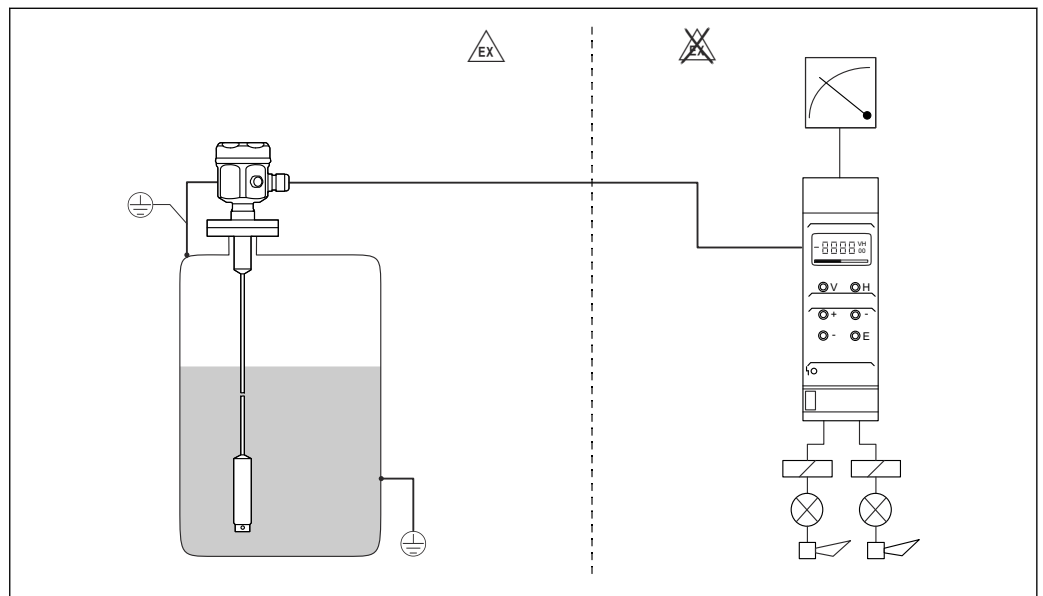

1 Level measurement

A0040754

Input

Measured variable Continuous measurement of change in capacitance between the probe rope and container wall, depending on the level of a liquid.
The probe covered -> high capacitance.
The probe not covered -> low capacitance.

Measuring range

- measuring frequency: 500 kHz
- span ΔC
 - recommended: 25 to 4 000 pF
 - possible: 2 to 4 000 pF
- final capacitance C_E : max. 4 000 pF
- adjustable initial capacitance C_A :
 - < 6 m (20 ft) 0 to 2 000 pF
 - > 6 m (20 ft) 0 to 4 000 pF

Measuring condition Measuring range L1 is possible from the tip of the probe to the process connection.

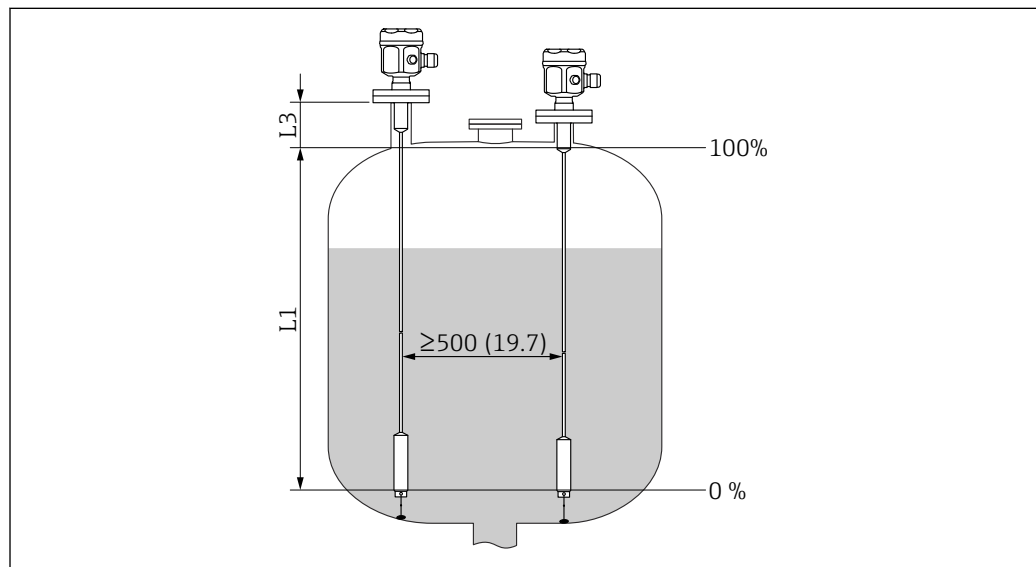

A0040579

Unit of measurement mm (in)

L1 Measuring range

L3 Inactive length

i When installing in a nozzle, use inactive length L3.

The 0 % and 100 % calibration can be inverted.

Output

Output signal

FEI50H (4 to 20 mA / HART version 5)

3.8 to 20.5 mA with HART protocol

FEI57C (PFM output)

The transmitter superimposes current pulses (PFM signal 60 to 2 800 Hz) with a pulse width of approximately 100 μ s and a current strength of approximately 8 mA on the supply current.

Signal on alarm

FEI50H (4 to 20 mA / HART version 5)

Fault diagnosis can be called up via:

- red LED on the local display
- error symbol on the local display
- plain text on the display
- current output 22 mA
- digital interface: HART status error message

FEI57C (PFM output)

Fault diagnosis can be called up via:

- red LED on the local display
- local display at switching units

Linearization

FEI50H (4 to 20 mA / HART version 5)

The Liquicap M linearization function enables the conversion of the measured value into any desired length or volume units. Linearization tables for volume calculation of horizontal cylindrical tanks and spherical tanks are pre-programmed. Any other tables with up to 32 value pairs can be input manually or semi-automatically.

FEI57C (PFM output)

Linearization is performed in the transmitters.

Power supply

Terminal assignment

FEI50H (4 to 20 mA / HART version 5)

The twin-core connecting cable is connected to the screw terminals with conductor cross-section 0.5 to 2.5 mm² (20 to 13 AWG) in the connection compartment at the electronic insert. If the superimposed communication signal (HART) is used, a shielded cable must be used with the shielding connected at the sensor and power supply. Protective circuits against reverse polarity, HF influences, and overvoltage peaks are integrated.



The shielding must be connected to the sensor and power supply. Protective circuits against reverse polarity, HF influences, and overvoltage peaks are integrated.

For more information see document "EMC test procedures" TI00241F.

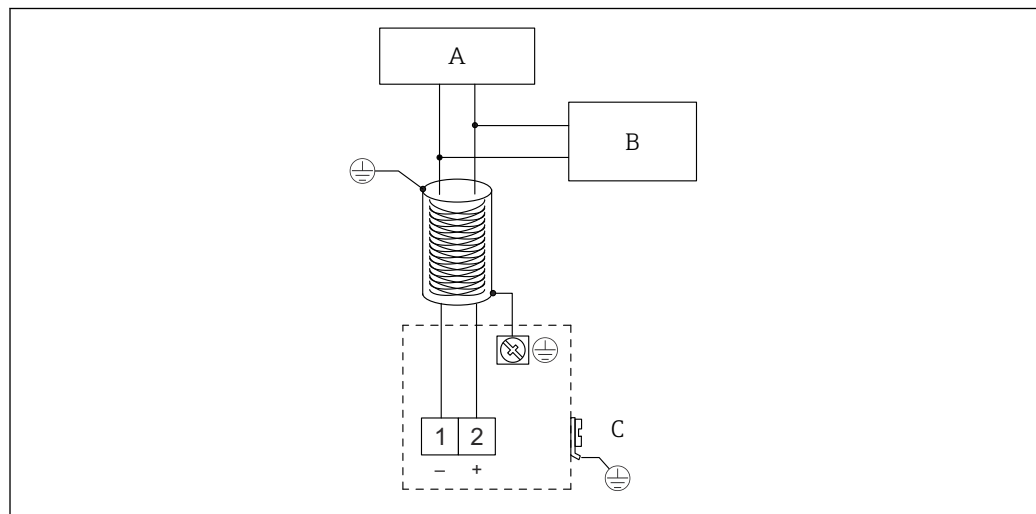

A0040479

- A Supply voltage, communication resistor 250 Ω
 B Commubox FXA195
 C Grounding terminal

FEI57C (PFM output)

The twin-core, shielded connecting cable with a cable resistance of max. 25 Ω per core is connected to the screw terminals (conductor cross-section 0.5 to 2.5 mm (0.02 to 0.1 in)) in the connection compartment.



The shielding must be connected to the sensor and power supply. Protective circuits against reverse polarity, HF influences, and overvoltage peaks are integrated.

For more information see document "EMC test procedures" TI00241F.

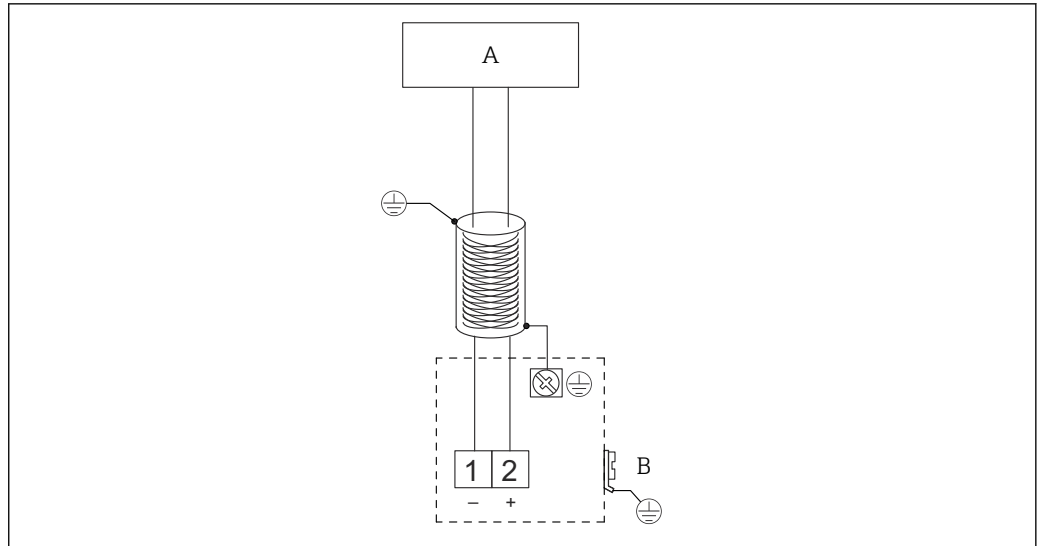

A0040776

- A Switching unit
- B Grounding terminal

Connector

For the version with a connector M12, the housing does not have to be opened for connecting the signal line.

PIN assignment for M12 connector

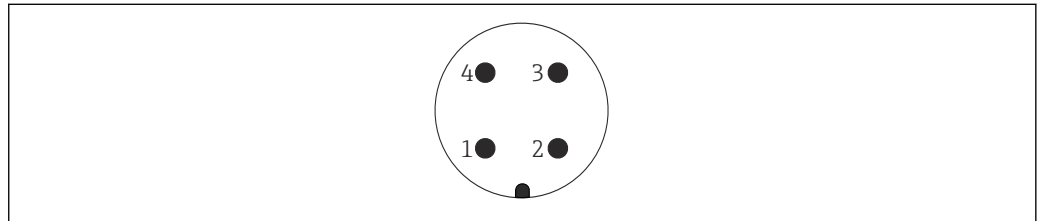

A0011175

- 1 Positive potential
- 2 Not used
- 3 Negative potential
- 4 Ground

Supply voltage

All of the following voltages are terminal voltages directly at the device.

FEI50H (4 to 20 mA / HART version 5)

- 12.0 to 36.0 V_{DC} - a device mounted in the non-hazardous area
- 12.0 to 30.0 V_{DC} - a device mounted in the hazardous areas Ex ia
- 14.4 to 30.0 V_{DC} - a device mounted in the hazardous areas Ex d

FEI57C (PFM output)

14.8 V_{DC} from the associated supply unit

 Both electronic inserts have integrated reverse polarity protection.

Power consumption

FEI50H (4 to 20 mA / HART version 5)

- minimum: 40 mW
- maximum: 800 mW

FEI57C (PFM output)

maximum: 250 mW

Current consumption

FEI50H (4 to 20 mA / HART version 5)

- current consumption: 3.8 to 22 mA
- HART multidrop operation: 4 mA
- residual ripple HART: 47 to 125 Hz U_{SS} = 200 mV with 500 Ω
- noise HART: 0.5 to 10 kHz U_{eff} < 2.2 mV with 500 Ω

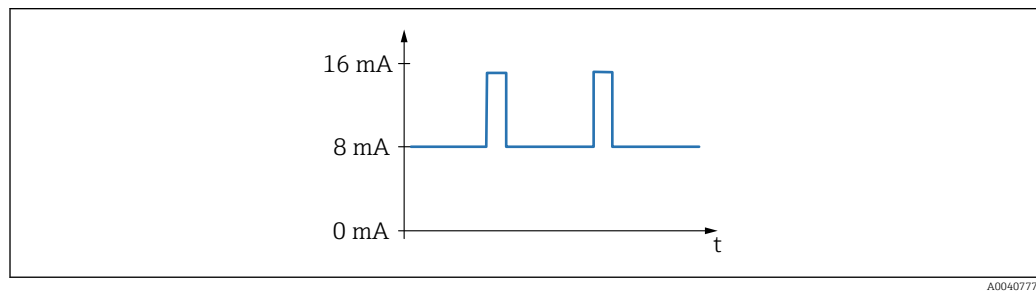
FEI57C (PFM output)

2 Frequency 60 to 2 800 Hz

Cable entries

Cable gland
M20×1.5¹⁾ - for Ex d only cable entry
Two cable glands are included in the scope of delivery.
Cable entry
G½ or ½NPT

Performance characteristics**Reference operating conditions**

Room temperature: +20 °C (+68 °F)±5 °C (±8 °F).
Span: ΔC = 25 to 4 000 pF recommended, 2 to 4 000 pF possible.

Maximum measured error

Non-repeatability (reproducibility) as per DIN 61298-2:
maximum ±0.1 %
Non-linearity for limit point setting (linearity) as per DIN 61298-2:
maximum ±0.5 %

Influence of ambient temperature

Electronic insert
< 0.06 %/10 K related to the full-scale value
Separate housing
change in capacitance of connecting cable 0.015 pF / m per K

Influence of process pressure

In the case of fully insulated probes in conductive liquids:
< 10.0 % related to the full scale value

Switch-on behavior

FEI50H (4 to 20 mA / HART version 5)
14 s, stable measured value after the switch-on procedure, start-up in safe status 22 mA
FEI57C (PFM output)
1.5 s, stable measured value after the switch-on procedure, start-up in safe status 22 mA

1) Metric fine thread.

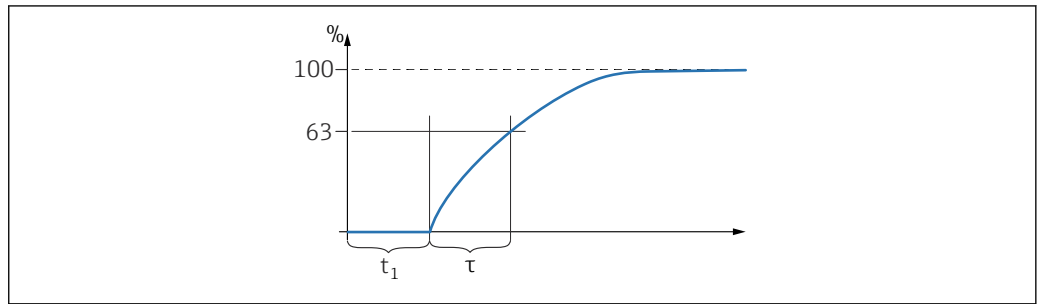
Measured value reaction time

A0040622

τ Time constant
 t_1 Dead time

FEI50H (4 to 20 mA / HART version 5)

Operating mode: $t_1 \leq 0.3$ s

SIL operating mode: $t_1 \leq 0.5$ s

FEI57C (PFM output)

Observe time constant of switching unit.

$t_1 = 0.3$ s

Response time**FEI50H (4 to 20 mA / HART version 5)**

The response time affects the speed at which the display and the current output react to changes in the level.

The factory setting for time constant $\tau = 1$ s; 0 to 60 s can be set.

Accuracy of factory calibration

Empty calibration (0 %) and full calibration (100 %):

- probe length < 2 m (6.6 ft)
 ≤ 5 mm (0.2 in)
- probe length > 2 m (6.6 ft)
 approximately ≤ 2 %

Reference conditions for the factory calibration:

- medium conductivity ≥ 100 $\mu\text{S}/\text{cm}$
- minimum distance to tank wall = 250 mm (9.84 in)

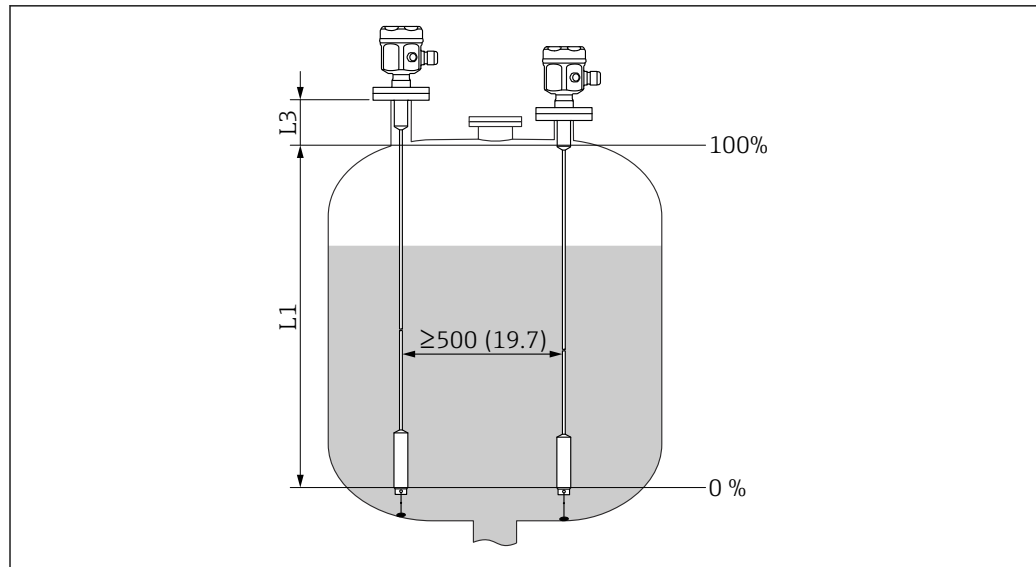

Unit of measurement mm (in)

L1 Measuring range from the tip of the probe to the process connection

L3 The inactive length



In an installed state, recalibration is only necessary when:

- the 0 % or the 100 % values have to be adjusted specifically for the customer
- the liquid is not conductive
- the probe distance to the tank wall is < 250 mm (9.84 in)

Resolution

FEI50H (4 to 20 mA / HART version 5)

Analog in % (4 to 20 mA)

- 11 bit/ 2 048 steps, 8 μ A
- the resolution of the electronics can be directly converted to units of length of the probe e.g. rope
probe length is 1 000 mm, resolution equals 1 000 mm/2048 = 0.48 mm

FEI57C (PFM output)

Zero frequency $f_0 = 60$ Hz

- sensitivity of the electronic insert = 0.685 Hz/pF
- entry in switching unit FMC671 under V3H5 and V3H6 or V7H5 and V7H6

Installation

Rope probes

The probe can be installed from above in conductive tanks made from metal.

If the process connection of the probe is insulated from the metal tank using a seal material, then the ground connection on the probe housing must be connected to the tank using a short line.

- i** The probe may not come into contact with the container wall! Do not install probes in the area of the filling curtain.
 - If multiple probes are mounted next to each other, a minimum distance of 500 mm (19.7 in) between the probes must be observed.
 - When mounting, ensure there is a good electrically conductive connection between the process connection and the tank. Use an electrically conductive sealing band for example.

- i** A fully insulated rope probe may be neither shortened nor extended.
Damaged insulation of the probe rope causes improper measurements.

The following application examples show the vertical installation for continuous level measurement.

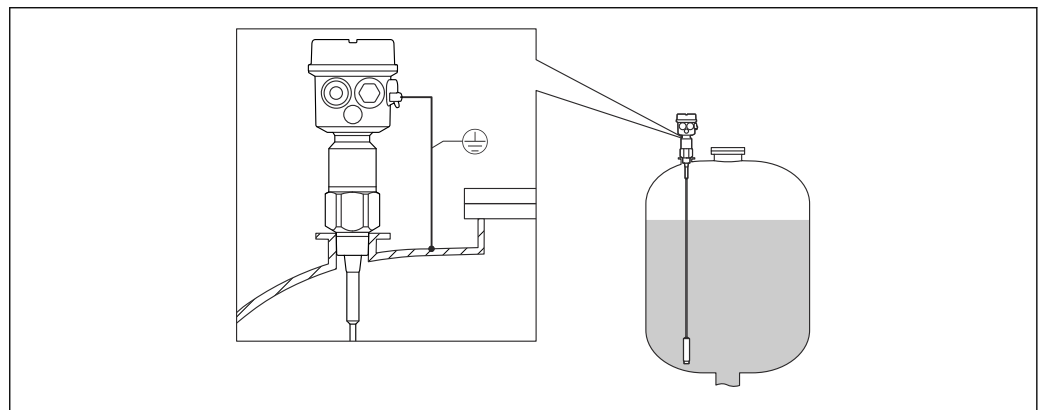

A0040451

3 *Rope probe*

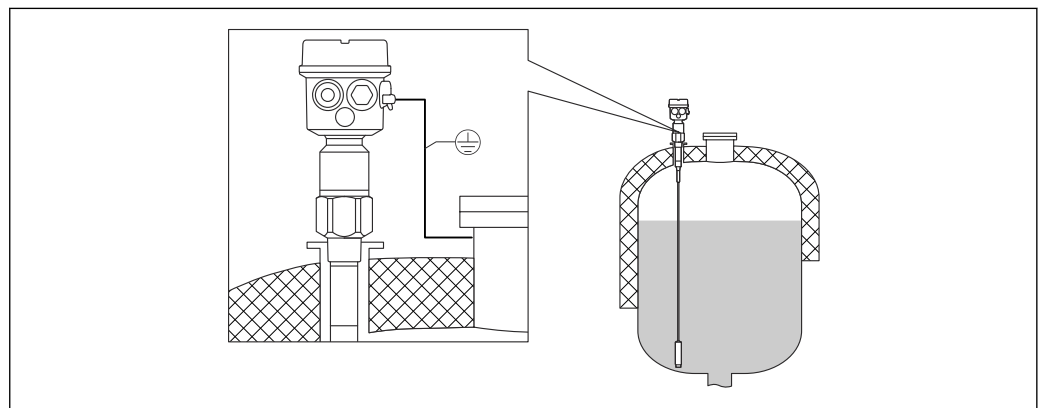

A0040452

4 *A probe with inactive length for the insulated tanks*

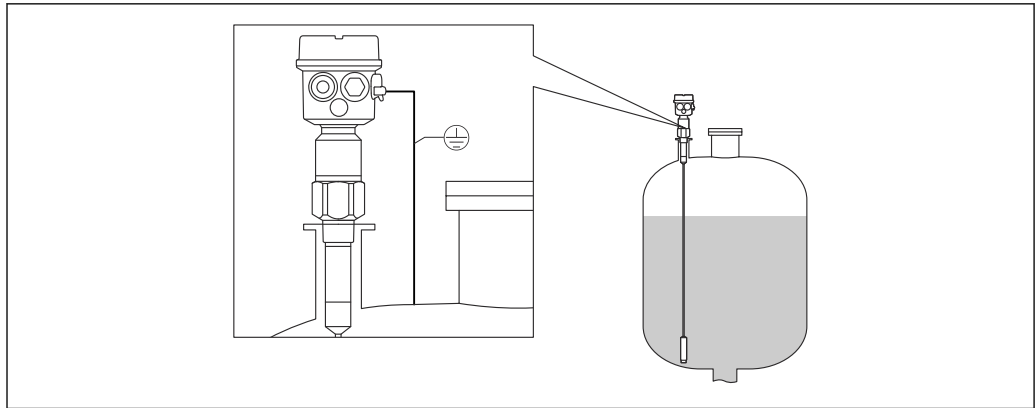

A0040453

5 A probe with fully insulated inactive length for mounting nozzles

Shortening the rope



For information about the shortening kit, see Brief Operating Instructions KA061F/00.

Tensioning weight with tension

The end of the probe needs to be secured if the probe would otherwise touch the silo wall or another part in the tank. This is what the internal thread in the probe weight is intended for. The bracing can be conductive or insulating to the tank wall.

To avoid too high tensile load, the rope should be loose or guyed with a spring. The maximum tensile load may not exceed 200 Nm (147.5 lbf ft).

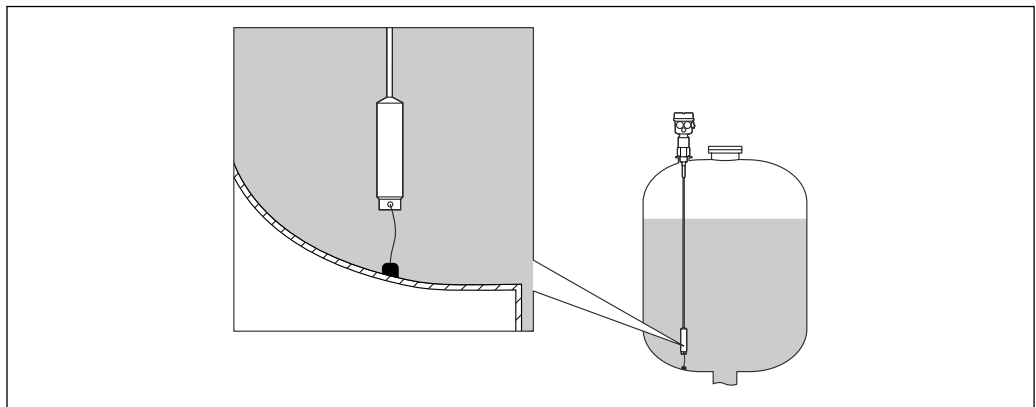

A0040462

Probe with separate housing

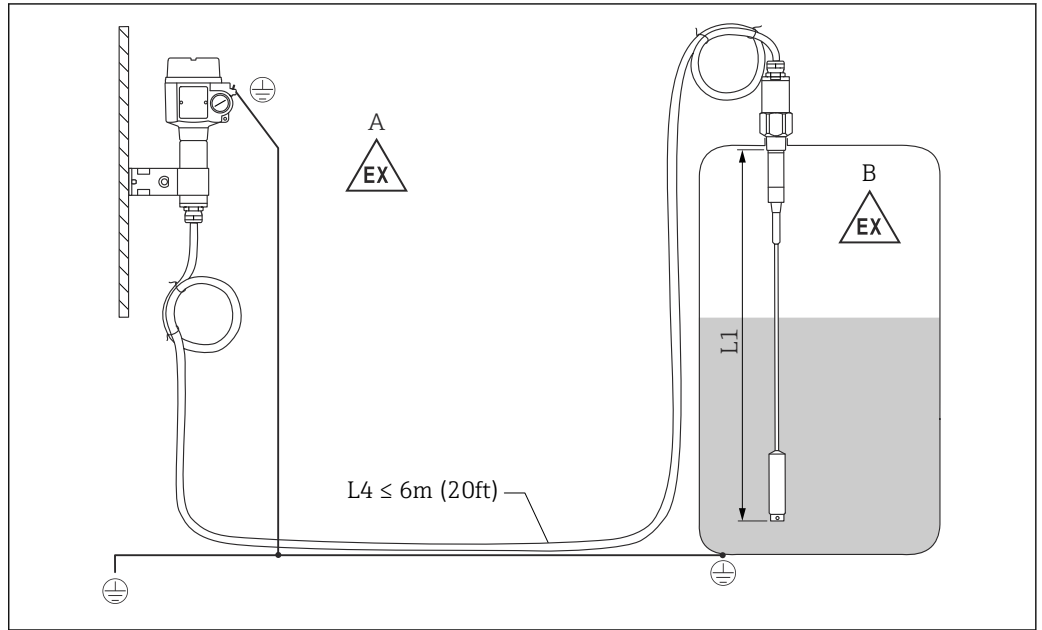

A0040473

6 Connection of the probe and separate housing

- A Explosive zone 1
- B Explosive zone 0
- L1 Rope length: max 9.7 m (32 ft)
- L4 Cable length: max. 6 m (20 ft)

The maximum cable length L4 and rope length L1 cannot exceed 10 m (33 ft).

i The maximum cable length between the probe and separate housing is 6 m (20 ft). The required cable length must be indicated in the ordering process of a Liquicap M with separate housing.

If the cable connection has to be shortened or led through a wall, then it must be separated from the process connection.

Extension heights: separate housing

- i** The cable:
 - has a minimum bending radius of $r \geq 100$ mm (3.94 in)
 - diameter \varnothing 10.5 mm (0.14 in)
 - outer jacket made of silicone, notch resistance

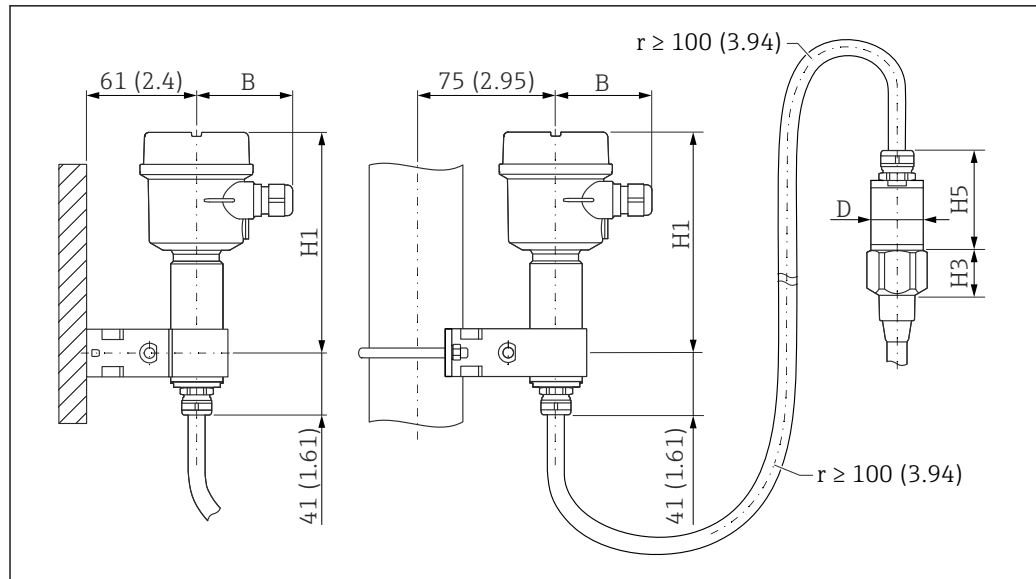

7 Housing side: wall mounting, pipe mounting, and sensor side. Unit of measurement mm (in)

Values of parameters²⁾:

Polyester housing (F16)

- B: 76 mm (2.99 in)
- H1: 172 mm (6.77 in)

Polyester housing (F15)

- B: 64 mm (2.52 in)
- H1: 166 mm (6.54 in)

Aluminum housing (F17)

- B: 65 mm (2.56 in)
- H1: 177 mm (6.97 in)

D and H5 parameter

- rope probe without fully insulated inactive length and threads G $\frac{3}{4}$ ", G1", NPT $\frac{3}{4}$ ", NPT1", Clamp 1", Clamp 1 $\frac{1}{2}$ ", Universal \varnothing 44 mm (1.73 in), flange < DN50, ANSI 2", 10K50:
 - D: 38 mm (1.5 in)
 - H5: 66 mm (2.6 in)
- rope probe without fully insulated inactive length and threads G1 $\frac{1}{2}$ ", NPT1 $\frac{1}{2}$ ", Clamp 2", DIN 11851, flange \geq DN50, ANSI 2", 10K50
 - D: 50 mm (1.97 in)
 - H5: 89 mm (3.5 in)
- rope probe with fully insulated inactive length:
 - D: 38 mm (1.5 in)
 - H5: 89 mm (3.5 in)

Wall bracket

-  The wall bracket is a part of the scope of delivery.
- To use the wall bracket as a drill template, the wall bracket must be first screwed to the separate housing.
- The distance between the holes is reduced by screwing it to the separate housing.

2) See parameters on the drawings.

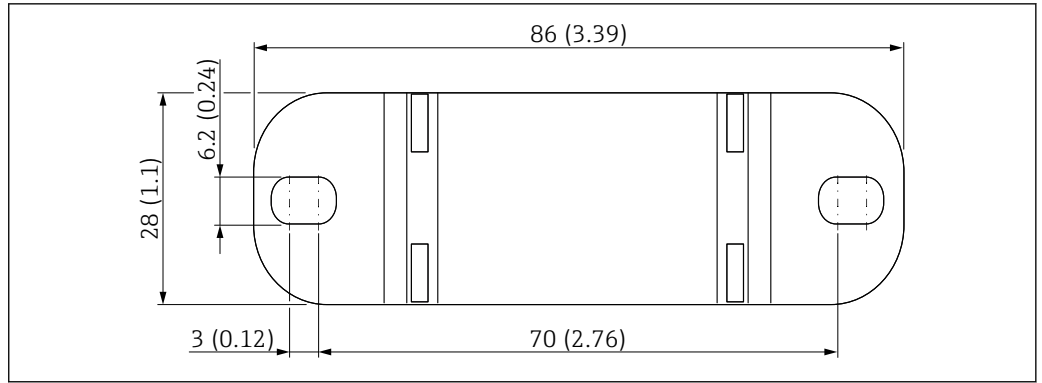

A0033881

Unit of measurement mm (in)

Environment

Ambient temperature range	<ul style="list-style-type: none"> ■ F16 housing: -40 to +70 °C (-40 to +158 °F) ■ remaining housing: -50 to +70 °C (-58 to +158 °F) ■ observe derating ■ use a protective cover, when operating outdoors
Storage and transport	For storage and transportation, pack the device to protect it against impact. The original packing offers the best protection for this. The permitted storage temperature is -50 to +85 °C (-58 to +185 °F).
Climate class	DIN EN 60068-2-38/IEC 68-2-38: Z/AD check
Vibration resistance	DIN EN 60068-2-64/IEC 68-2-64: 20 to 2 000 Hz, 0.01 g ² /Hz
Shock resistance	DIN EN 60068-2-27/IEC 68-2-27: 30 g acceleration
Cleaning	<p>Housing: Make sure that the housing surface and seals are resistant to cleaning agents.</p> <p>Probe: Depending on the application, buildup of contamination or soiling can form on the rope. A high level of material buildup can affect the measurement result. The regular cleaning of the rope is recommended if the medium tends to create a high level of buildup. Make sure that the insulation of the rope is not damaged if hosing down or during mechanical cleaning.</p>
Degree of protection	<p> All protection degree regarding EN60529. NEMA4X protection degree regarding NEMA250.</p> <p>Polyester housing F16 Protection degree:</p> <ul style="list-style-type: none"> ■ IP66 ■ IP67 ■ NEMA 4X <p>Stainless steel housing F15 Protection degree:</p> <ul style="list-style-type: none"> ■ IP66 ■ IP67 ■ NEMA 4X

Aluminum housing F17

Protection degree:

- IP66
- IP67
- NEMA 4X

Aluminum housing F13 with gas-tight process seal

Protection degree:

- IP66
- IP68 ³⁾
- NEMA 4X

Stainless steel housing F27 with gas-tight process seal

Protection degree:

- IP66
- IP67
- IP68 ³⁾
- NEMA 4X

Aluminum housing T13 with gas-tight process seal and separate connection compartment (Ex d)

Protection degree:

- IP66
- IP68 ³⁾
- NEMA 4X

Separate housing

Protection degree:

- IP66
- IP68 ³⁾
- NEMA 4X

Electromagnetic compatibility (EMC)

Interference emission to EN 61326, Electrical Equipment Class B. Interference immunity to EN 61326, Annex A (Industrial) and NAMUR Recommendation NE 21 (EMC).

Failure current is in accordance with NAMUR NE43: FEI50H = 22 mA.

A standard commercial instrument cable can be used.



Information on connecting shielded cables is provided in Technical Information TI00241F "EMC test procedures".

3) Only with M20 cable entry or G½ thread.

Process

Process temperature range

The following diagrams apply for:

- insulation
 - PTFE
 - PFA
 - FEP
- standard applications outside hazardous areas

i The temperature is restricted to $T_a -40\text{ °C}$ (-40 °F) when the polyester housing F16 is used or if additional option B is selected: free from paint-wetting impairment substances, only FMI51.

Probe with compact housing

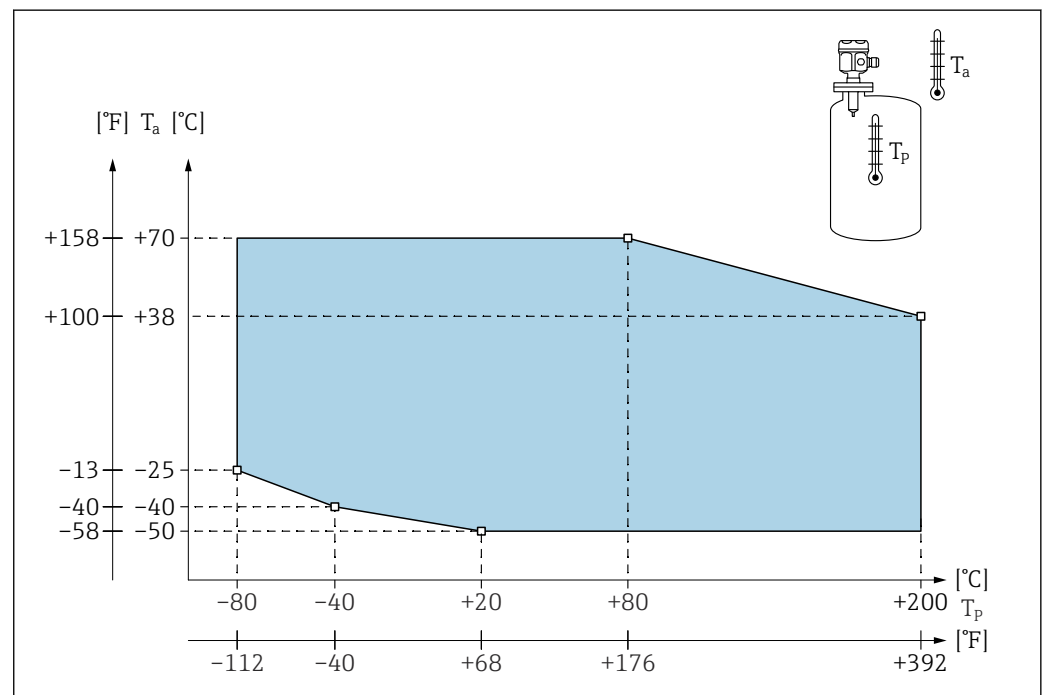

T_a Ambient temperature

T_p Process temperature

A0043638

Probe with separate housing

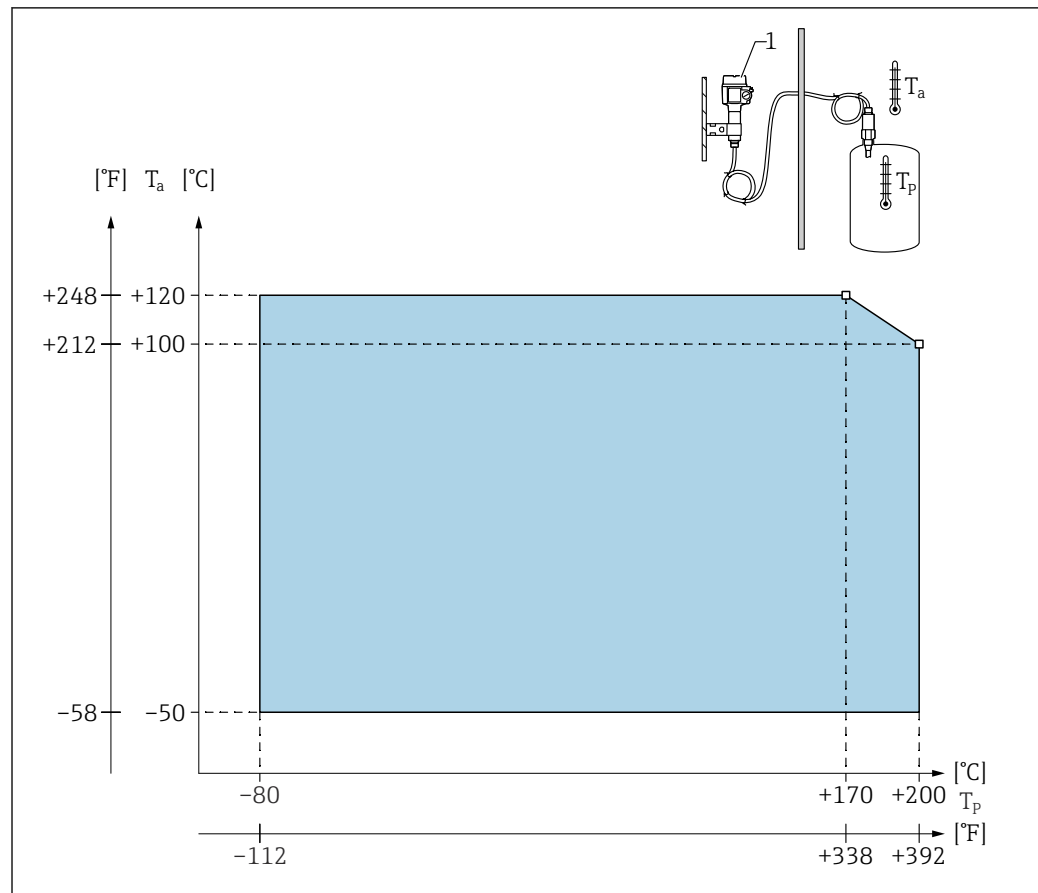

A0043639

T_a Ambient temperature

T_p Process temperature

1 The permitted ambient temperature at the separate housing is the same as indicated for the compact housing.

Influence of process temperature

Error in case of fully insulated probes typically 0.13 %/K related to the full-scale value.

Process pressure limits



The process pressure limits depends on process connections.

See also chapter "Process connections" → 29.

Rope probe without inactive length or with inactive length in 316L



E+H Configurator settings:

- Feature: 20
- Options: 1, 2, 5
- -1 to 25 bar (-14.5 to 362.5 psi)
- -1 to 100 bar (-14.5 to 1 450 psi)
- in regards to an inactive length, the maximum permitted process pressure is 63 bar (913.5 psi)
- for CRN approval and inactive length: the maximum permitted process pressure is 32 bar (464 psi)

Rope probe with fully insulated inactive length



E+H Configurator settings:

- Feature: 20
- Options: 3, 6
- 1 to 50 bar (-14.5 to 725 psi)

Refer to the following standards for the pressure values permitted at higher temperatures:

- EN 1092-1: 2005 Table, Appendix G2
With regard to its resistance and temperature property, the material 1.4435 is identical to 1.4404 (AISI 316L) which is grouped under 13E0 in EN 1092-1 Tab. 18. The chemical composition of the two materials can be identical.
- ASME B 16.5a - 1998 Tab. 2-2.2 F316
- ASME B 16.5a - 1998 Tab. 2.3.8 N10276
- JIS B 2220

The lowest value from the derating curves of the device and the selected flange applies.

Pressure and temperature derating

 See also chapter "Process connections" →  29

For rope probes without inactive length or with inactive length in 316L, process connections 3/4", 1", flanges <DN50, <ANSI 2", <JIS 10K and process connections 3/4", 1", flanges <DN50, <ANSI 2", <JIS 10K

Rope insulation: FEP, PFA

 **E+H Configurator settings:**

- Feature: 20
- Options: 1, 2, 5

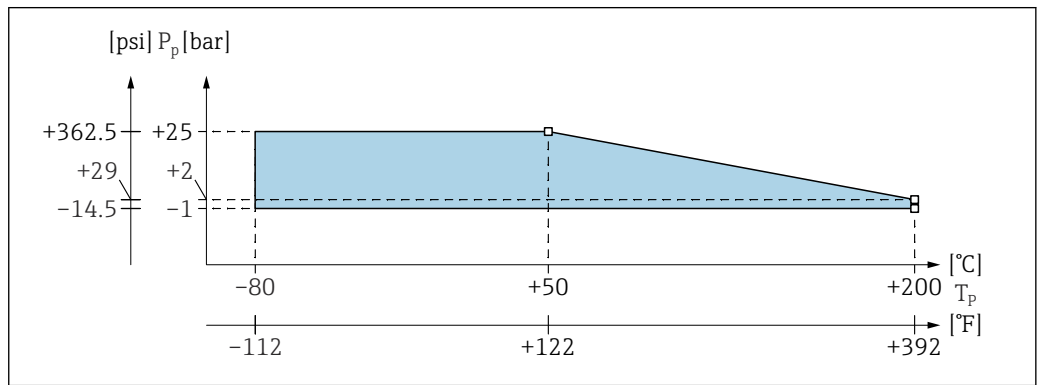

P_p Process pressure
 T_p Process temperature

A0043640

For rope probes without inactive length or with inactive length in 316L, process connections 1½", flanges ≥DN50, ≥ANSI 2", ≥JIS 50A

Rope insulation: FEP, PFA

i E+H Configurator settings:

- Feature: 20
- Options: 1, 2, 5

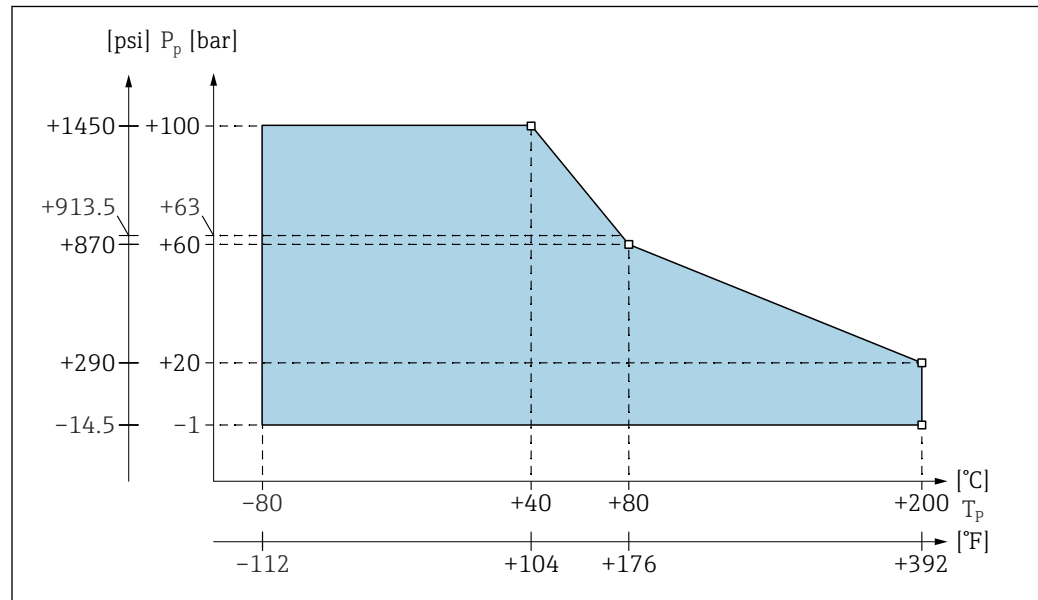

A0043641

P_p Process pressure

T_p Process temperature

63 Process pressure for probes with an inactive length

For rope probe with a fully insulated inactive length

Rope insulation: FEP, PFA

i E+H Configurator settings:

- Feature: 20
- Options: 3, 6

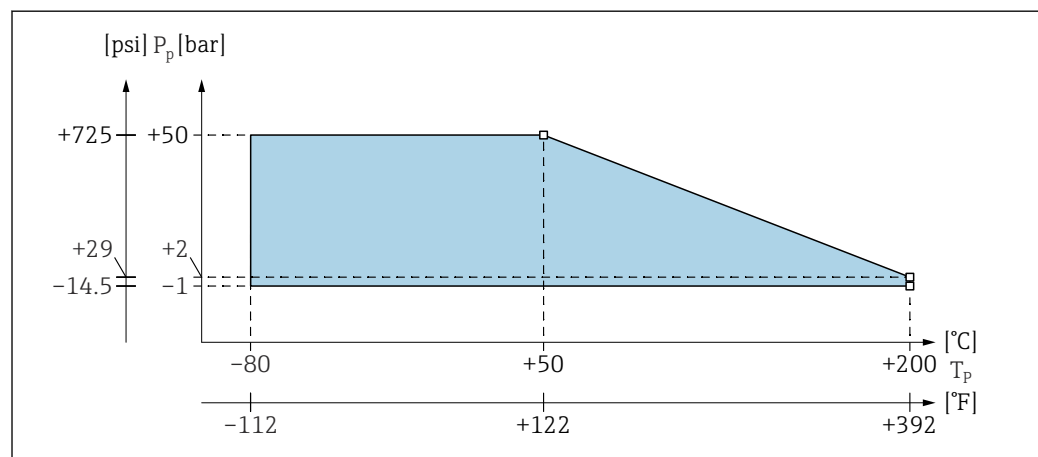

A0043642

P_p Process pressure

T_p Process temperature

Conductivity

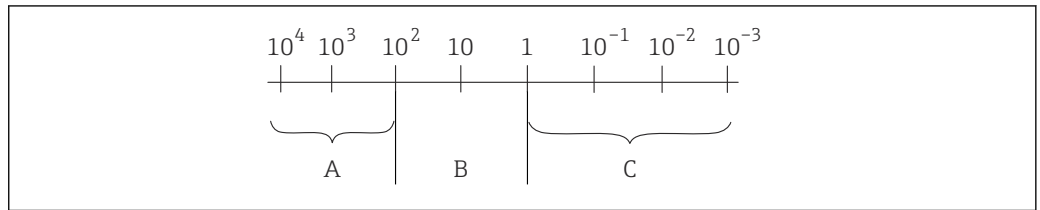

8 Unit of measurement: $\mu\text{S}/\text{cm}$

- A The measuring accuracy is independent of the conductivity and dielectric constant value. The factory calibration is valid in this range.
- B The measuring accuracy depends on the dielectric constant value and the conductivity of the medium. Measurement not recommendable, select therefore a different measurement principle.
- C The measuring accuracy depends on the dielectric constant value.

Typical dielectric constant (DC) values:

- air: $1 \mu\text{S}/\text{cm}$
- vacuum: $1 \mu\text{S}/\text{cm}$
- general liquified gases: 1.2 to $1.7 \mu\text{S}/\text{cm}$
- gasoline: $1.9 \mu\text{S}/\text{cm}$
- diesel fuel: $2.1 \mu\text{S}/\text{cm}$
- general oils: 2 to $4 \mu\text{S}/\text{cm}$
- methyl ether: $5 \mu\text{S}/\text{cm}$
- butanol: $11 \mu\text{S}/\text{cm}$
- ammonia: $21 \mu\text{S}/\text{cm}$
- latex: $24 \mu\text{S}/\text{cm}$
- ethanol: $25 \mu\text{S}/\text{cm}$
- caustic soda: 22 to $26 \mu\text{S}/\text{cm}$
- acetone: $20 \mu\text{S}/\text{cm}$
- glycerine: $37 \mu\text{S}/\text{cm}$
- water: $81 \mu\text{S}/\text{cm}$



Further information and dielectric constants (DC values) in the Download Area of the Endress+Hauser web site:

- Endress+Hauser DC manual (CP01076F)
- Endress+Hauser "DC Values App" on Android and iOS

Mechanical construction

Design dimensions

Housing

Polyester housing F16

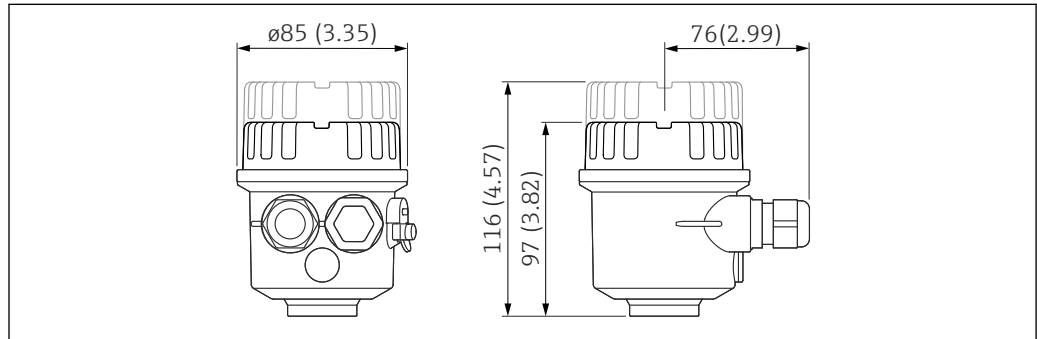

A0040691

Unit of measurement mm (in)

Stainless steel housing F15

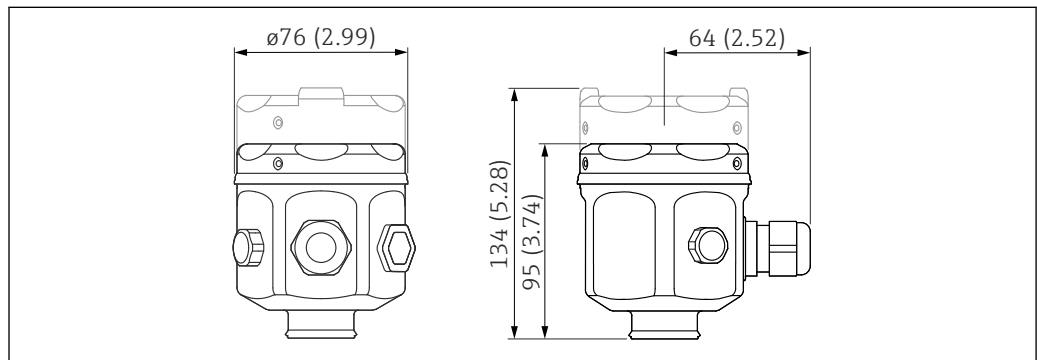

A0040692

Unit of measurement mm (in)

Stainless steel housing F17

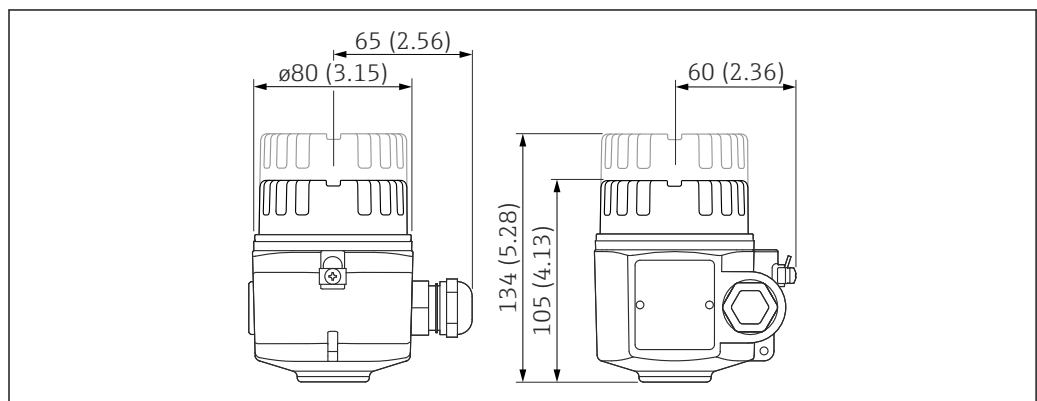

A0040693

Unit of measurement mm (in)

Aluminum housing F13

With the gas-tight process seal.

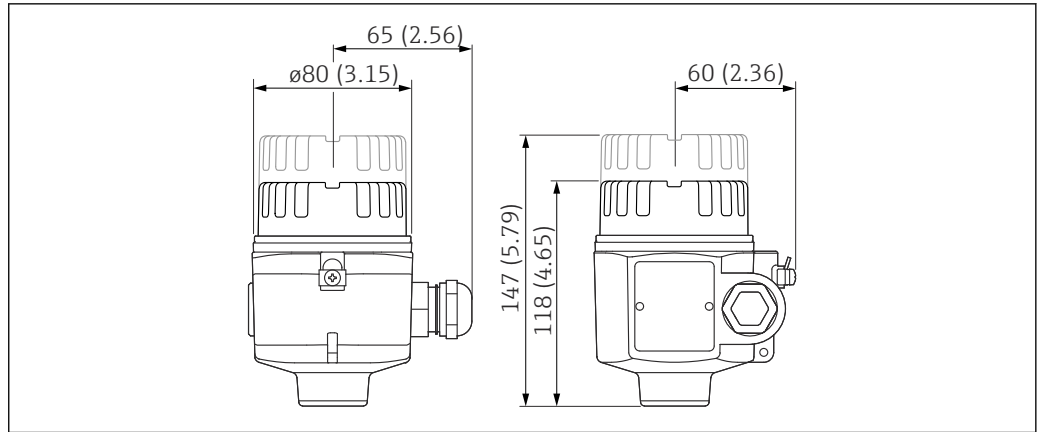

A0040694

Unit of measurement mm (in)

Stainless steel housing F27

With the gas-tight process seal.

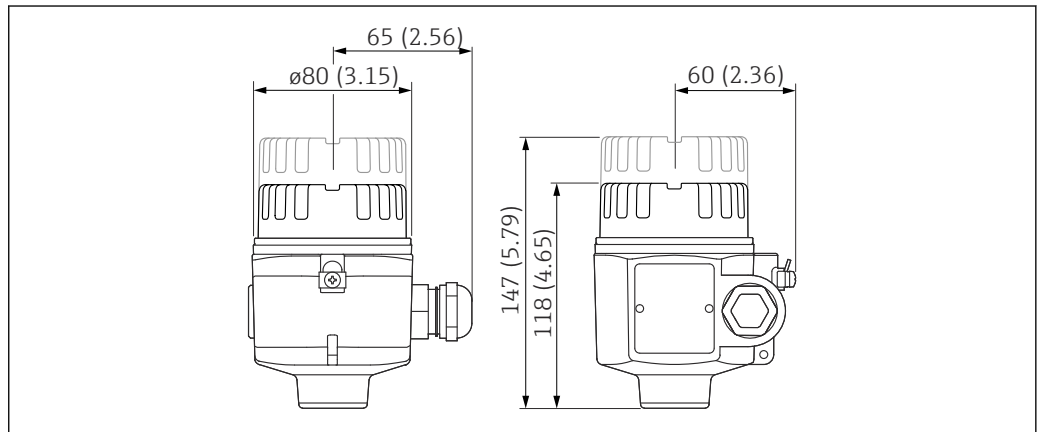

A0040694

Unit of measurement mm (in)

Aluminum housing T13

With separate connection compartment and gas-tight process seal.

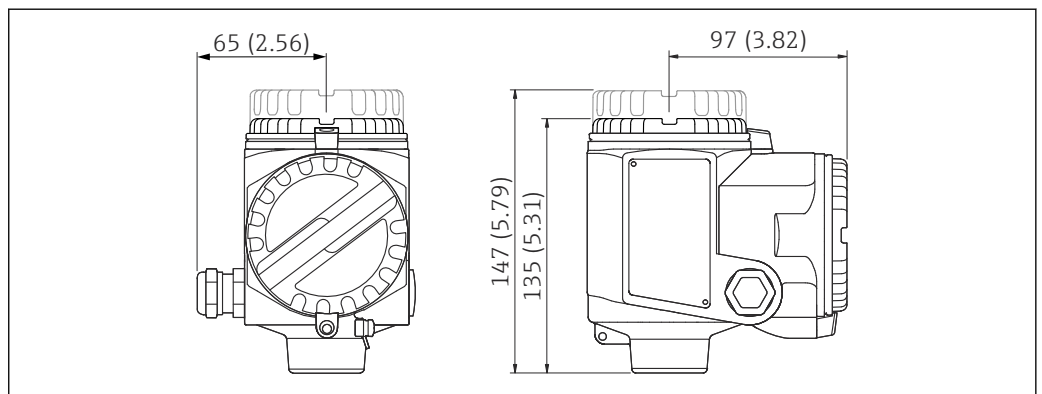

A0040695

Unit of measurement mm (in)

The extension height of housing with adapter

List of abbreviations:

- G - order code
- H1 - height without display
- H2 - height with display

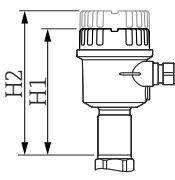
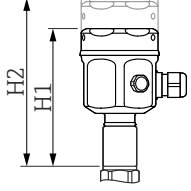
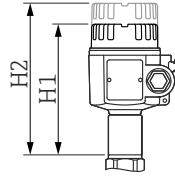
	A ¹⁾	B ²⁾	C ³⁾
	 <p style="text-align: right; font-size: small;">A0040696</p>	 <p style="text-align: right; font-size: small;">A0040697</p>	 <p style="text-align: right; font-size: small;">A0040698</p>
G	2	1	3
H1	143 mm (5.63 in)	141 mm (5.55 in)	150 mm (5.91 in)
H2	162 mm (6.38 in)	179 mm (7.05 in)	179 mm (7.05 in)

- 1) Polyester housing F16
 2) Stainless steel housing F15
 3) Stainless steel housing F17

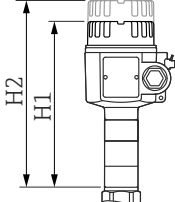
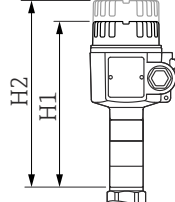
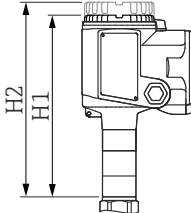
	D ¹⁾	E ²⁾	F ³⁾
	 <p style="text-align: right; font-size: small;">A0040699</p>	 <p style="text-align: right; font-size: small;">A0040699</p>	 <p style="text-align: right; font-size: small;">A0040700</p>
G	4	6	5
H1	194 mm (7.64 in)	194 mm (7.64 in)	210 mm (8.27 in)
H2	223 mm (8.78 in)	223 mm (8.78 in)	223 mm (8.78 in)

- 1) Aluminum housing F13
 2) Stainless steel housing F27
 3) Aluminum housing T13

Process connections

Thread G - DIN EN ISO 228-1

Seal material: elastomer

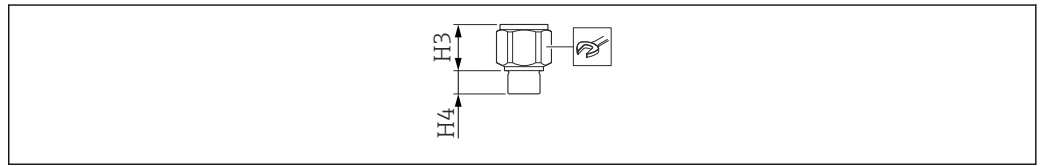

A0042280

List of abbreviations:

- p_{max} - maximum pressure value
- H3 - cone heights
- H4 - thread heights

A ¹⁾			B ²⁾
E+H Configurator settings:			
Feature: 20 Option: 1, 2, 5			Feature: 20 Option: 3, 6
Version			
G ^{3/4}	G1	G1 ^{1/2}	G1 ^{1/2}
Order code			
GDJ	GEJ	GGJ	GGJ
p_{max}			
25 bar (362.5 psi)	25 bar (362.5 psi)	100 bar (1450 psi)	50 bar (725 psi)
H3			
38 mm (1.5 in)	38 mm (1.5 in)	41 mm (1.61 in)	85 mm (3.35 in)
H4			
19 mm (0.75 in)	19 mm (0.75 in)	25 mm (0.98 in)	25 mm (0.98 in)
			
A0011222			
41	41	55	55

- 1) Rope probe without inactive length or with inactive length in 316L
- 2) Rope probe with fully insulated inactive length

Thread NPT - ANSI B 1.20.1

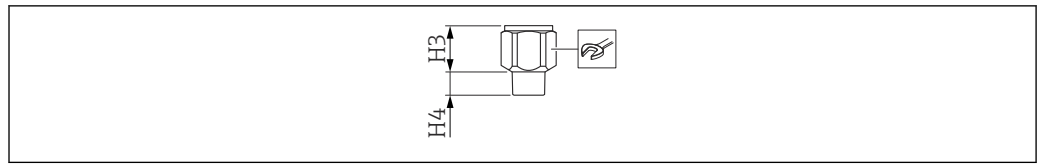

A0040702

List of abbreviations:

- p_{max} - maximum pressure value
- H3 - cone heights
- H4 - thread heights

A ¹⁾						B ²⁾
E+H Cofigurator settings:						
Feature: 20 Option: 1, 2, 5					Feature: 20 Option: 3, 6	
Version						
NPT½	NPT¾	NPT1	NPT¾	NPT1	NPT1½	NPT1½
Order code						
RCJ	RDJ	REJ	RDJ	REJ	RGJ	RGJ
p_{max}						
25 bar (362.5 psi)	25 bar (362.5 psi)	25 bar (362.5 psi)	25 bar (362.5 psi)	25 bar (362.5 psi)	100 bar (1450 psi)	50 bar (725 psi)
H3						
38 mm (1.5 in)	38 mm (1.5 in)	38 mm (1.5 in)	38 mm (1.5 in)	38 mm (1.5 in)	41 mm (1.61 in)	85 mm (3.35 in)
H4						
19 mm (0.75 in)	19 mm (0.75 in)	19 mm (0.75 in)	19 mm (0.75 in)	19 mm (0.75 in)	25 mm (0.98 in)	25 mm (0.98 in)
						
A0011222						
41	41	41	41	41	55	55

- 1) Rope probe without inactive length or with inactive length in 316L
 2) Rope probe with fully insulated inactive length

Threaded pipe joint - DIN11851

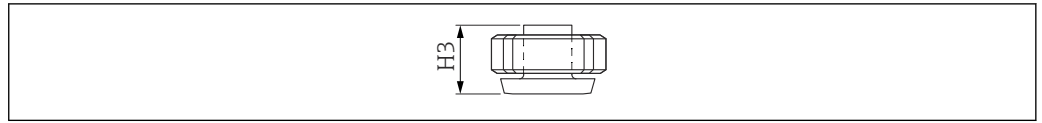

A0040703

List of abbreviations:

- P_{max} - maximum pressure value
- H3 - cone heights

A¹⁾	
E+H Configurator settings:	
Feature: 20	
Option: 1, 2, 5	
Version	
DN50 PN40	
Order code	
MRJ	
P_{max}	
40 bar (580 psi)	
H3	
66 mm (2.6 in)	
Surface roughness²⁾	
$\leq 0.8 \mu\text{m}$ (31.5 μin)	

- 1) Rope probe without inactive length or with inactive length in 316L
 2) Not in conjunction with inactive length

Tri-Clamp - ISO2852

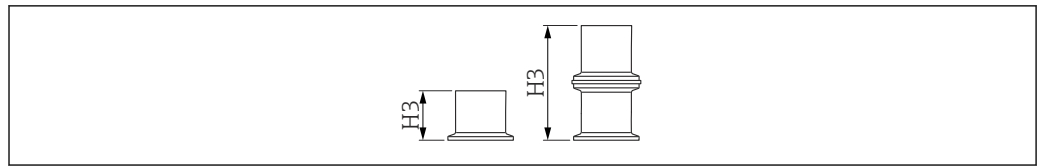

A0040704

List of abbreviations:

- p_{\max} - maximum pressure value
- H3 - cone heights

A ¹⁾		
E+H Configurator settings:		
Feature: 20		
Option: 1, 2, 5		
Version		
DN25 1 in	DN38 1.5 in	DN40-51 2 in
Order code		
TCJ	TJJ	TDJ
p_{\max}²⁾		
25 bar (362.5 psi)	25 bar (362.5 psi)	40 bar (580 psi)
H3		
57 mm (2.24 in)	57 mm (2.24 in)	66 mm (2.6 in)
Surface roughness³⁾		
$\leq 0.8 \mu\text{m}$ (31.5 μin)	$\leq 0.8 \mu\text{m}$ (31.5 μin)	$\leq 0.8 \mu\text{m}$ (31.5 μin)

- 1) Rope probe without inactive length or with inactive length in 316L
- 2) In the event of CRN approval, the maximum permitted process pressure is 11 bar (159.5 psi).
- 3) Not in conjunction with inactive length

Tri-Clamp clad - ISO2852

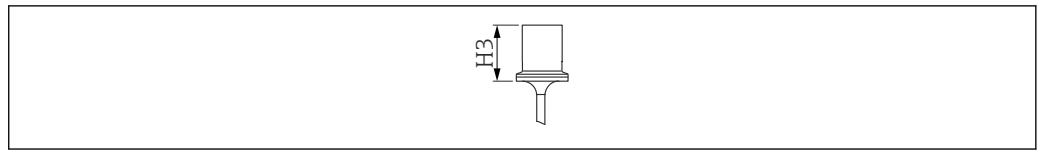

A0040705

List of abbreviations:

- p_{max} - maximum pressure value
- H3 - cone heights

A ¹⁾	
E+H Configurator settings:	
Feature: 20	
Option: 1	
Version	
DN38 1.5 in	DN40-51 2 in
Order code	
TJK	TDK
p_{max}²⁾	
16 bar (232 psi)	16 bar (232 psi)
H3	
66 mm (2.6 in)	66 mm (2.6 in)
Surface roughness³⁾	
$\leq 0.8 \mu\text{m}$ (31.5 μin)	$\leq 0.8 \mu\text{m}$ (31.5 μin)

- 1) Rope probe without inactive length
- 2) In the event of CRN approval, the maximum permitted process pressure is 11 bar (159.5 psi).
- 3) Not in conjunction with inactive length

Flanges



The process pressure depends on the chosen feature and the flange.

EN1092-1

ANSI B 16.5

JIS B2220

Version and order code:

- EN / B##
- ANSI / A##
- JIS / K##

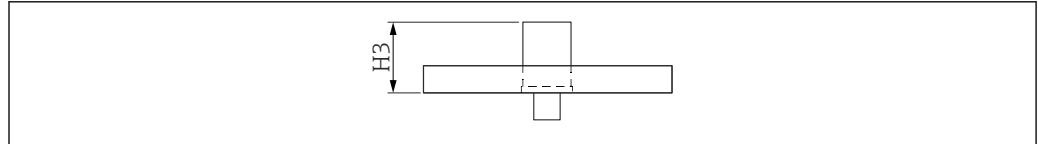

A0040706

A ¹⁾		B ²⁾
< DN50, < ANSI 2", < JIS 50A	≥ DN50, ≥ ANSI 2", ≥ JIS 50A	
E+H Configurator settings:		
Feature: 20 Option: 1, 2, 5		Feature: 20 Option: 3, 6
P_{max} ³⁾		
25 bar (362.5 psi)	100 bar (1450 psi)	50 bar (725 psi)
H3		
57 mm (2.24 in)	66 mm (2.6 in)	111 mm (4.37 in)
Dimensions with inactive length		
-	56 mm (2.2 in)	-
Additional information		
1 ⁴⁾	1 ⁴⁾	2 ⁵⁾

1) Rope probe without inactive length or with inactive length in 316L

2) Rope probe with fully insulated inactive length

3) Depends on flange

4) Also clad (PTFE)

5) Only clad (PTFE)

Hygiene connections for rope probes without inactive length

Thread G1 with flush-mounted seal

For weld-in adapter, see chapter "Accessories" →  45.

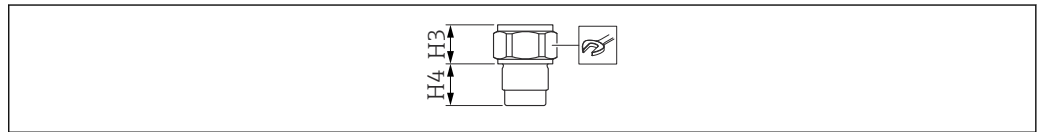

A0040708

List of abbreviations:

- p_{max} - maximum pressure value
- H3 - cone heights
- H4 - thread heights

A¹⁾	
E+H Configurator settings:	
Feature: 20	
Option: 1	
Version	
G1	
Order code	
GWJ	
P_{max}	
25 bar (362.5 psi)	
H3	
30 mm (1.18 in)	
H4	
27 mm (1.06 in)	
	
<small>A0011222</small>	
41	

1) Rope probe without inactive length

Adapter 44 mm (1.73 in) with flush-mounted seal

Version

Universal adapter

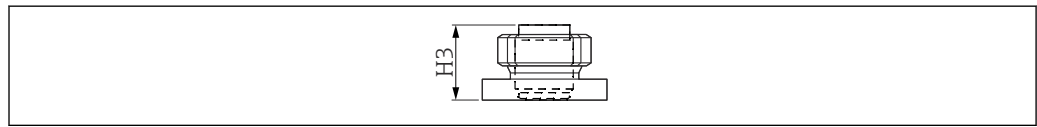

A0040709

A ¹⁾	
E+H Configurator settings:	
Feature: 20	
Option: 1	
Order code	
UPJ	
p_{max} ²⁾	
16 bar (232 psi)	
H3	
57 mm (2.24 in)	

- 1) Rope probe without inactive length
- 2) Tightening torque 10 Nm (7.37 lbf ft)

Rope probes



Remember that:

- the rope probe is not suitable for agitator tanks, high-viscosity liquids and plastic tanks
- the active probe rod (L1) is always fully insulated
- the total length of the probe from the sealing surface equals: $L = L1 + L3$
- the thickness of insulation for probe rope is 0.75 mm (0.03 in)
- for conductive liquids $> 100 \mu\text{S/cm}$, the probe is adjusted at the factory to the probe length ordered 0 to 100 %
- for nonconductive liquids $< 1 \mu\text{S/cm}$ the 0 % adjustment is performed at the factory and the 100 % adjustment has to be carried out on site
- in the range of the anchor weight the measurement is not linear
- all rope probes are prepared for tensioning in containers - tensioning weight or anchor hole
 - in case of media $< 1 \mu\text{S/cm}$, appropriate measures must be taken, e.g. a metallic reference point or a metallic tank
 - back-and-forth swinging of the rope directly influences the switch point. The probe must therefore be tightened
- the length tolerances L1, L3 equals:
 - $< 1 \text{ m}$ (3.3 ft) = 0 to -10 mm (0 to -0.39 in)
 - 1 to 3 m (3.3 to 9.8 ft) = 0 to -20 mm (0 to -0.79 in)
 - 3 to 6 m (9.8 to 20 ft) = 0 to -30 mm (0 to -1.18 in)
 - 6 to 12 m (20 to 39 ft) = 0 to -40 mm (0 to -1.57 in)

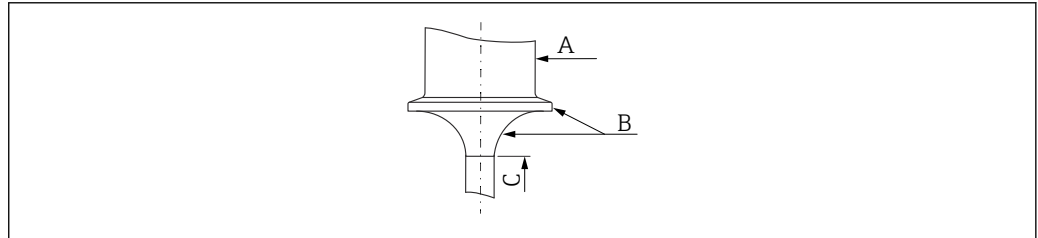

A0040742

- A 316L
- B PTFE
- C PFA

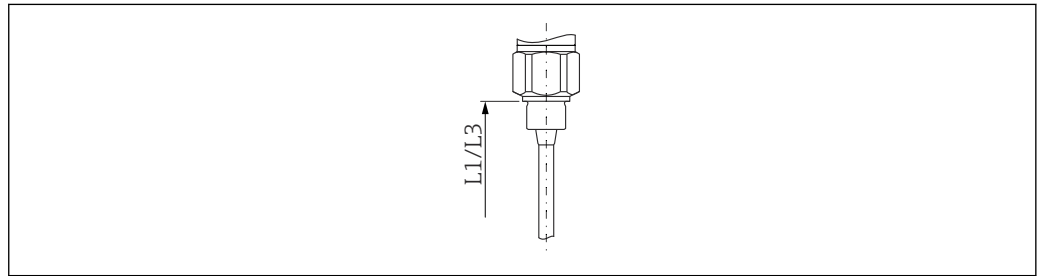

A0040755

9 The probe with G thread

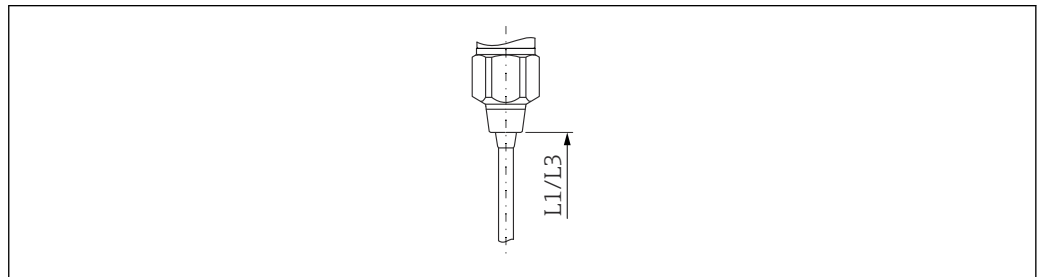

A0044665

10 The probe with the conical thread NPT

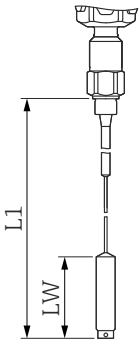
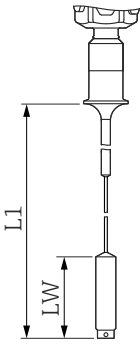
A ¹⁾	B ²⁾
 <p style="text-align: right; font-size: small;">A0040756</p>	 <p style="text-align: right; font-size: small;">A0040757</p>
Total length L	
420 to 10000 mm (1.4 to 33 ft)	420 to 10000 mm (1.4 to 33 ft)
Active rope length L1	
420 to 10000 mm (1.4 to 33 ft)	420 to 10000 mm (1.4 to 33 ft)
Inactive length L3	
-	-
Rope diameter	
4 mm (0.16 in)	4 mm (0.16 in)
Inactive length diameter	
-	-
Anchor weight length (LW)	
120 mm (4.72 in)	120 mm (4.72 in)
Anchor weight diameter	
22 mm (0.87 in)	22 mm (0.87 in)
Anchor hole diameter	
5 mm (0.2 in)	5 mm (0.2 in)
Tensile loading capacity of the rope at 20 °C (68 °F)	
200 N (44.96 lbf)	200 N (44.96 lbf)
For conductive liquids > 100 µS/cm	
✓	✓
Nonconductive liquids < 1 µS/cm	
-	-
For aggressive liquids	
✓	✓
For high-viscosity liquids	
-	-
For use in mounting nozzles	
-	-
The probe can be used in the event of condensate on tank ceiling	
-	-

1) Rope probe

2) Rope probe with Tri-Clamp clad

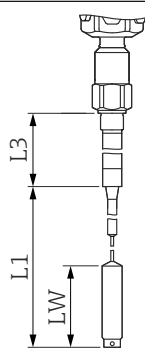
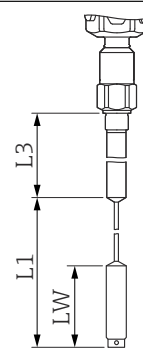
C ¹⁾		D ²⁾	
			
<small>A0040758</small>		<small>A0040759</small>	
Total length L			
570 to 10 000 mm (1.9 to 33 ft)		570 to 10 000 mm (1.9 to 33 ft)	
Active rope length L1			
420 to 9 850 mm (1.4 to 32 ft)		420 to 9 850 mm (1.4 to 32 ft)	
Inactive length L3			
150 to 2 000 mm (0.5 to 6.6 ft)		150 to 1 000 mm (0.5 to 39.4 in)	
Rope diameter			
4 mm (0.16 in)		4 mm (0.16 in)	
Inactive length diameter			
22 mm (0.87 in) ³⁾	43 mm (1.69 in) ⁴⁾	22 mm (0.87 in) ⁵⁾	
Anchor weight length (LW)			
120 mm (4.72 in)		120 mm (4.72 in)	
Anchor weight diameter			
22 mm (0.87 in)		22 mm (0.87 in)	
Anchor hole diameter			
5 mm (0.2 in)		5 mm (0.2 in)	
Tensile loading capacity of the rope at 20 °C (68 °F)			
200 N (44.96 lbf)		200 N (44.96 lbf)	
For conductive liquids > 100 µS/cm			
✓		✓	
Nonconductive liquids < 1 µS/cm			
✓		✓	
For aggressive liquids			
-		✓	
For high-viscosity liquids			
-		-	
For use in mounting nozzles			
✓		✓	

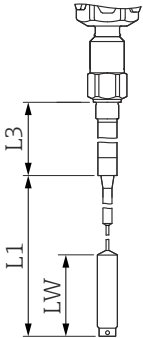
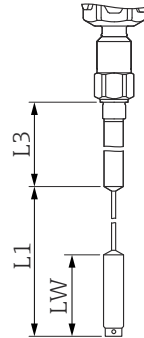
C ¹⁾	D ²⁾
 <p style="text-align: right; font-size: small;">A0040758</p>	 <p style="text-align: right; font-size: small;">A0040759</p>
The probe can be used in the event of condensate on tank ceiling	
✓	✓

- 1) Rope probe with inactive length
- 2) Rope probe with fully insulated inactive length
- 3) The diameter value of the inactive length depends on the process connection selected: Ø22: GDJ, GEJ, RDJ, REJ, TCJ, TJJ; Flange: ASME B16.5: NPS ≤ 1½", EN1092-1: ≤ DN40, JIS: ≤ 10K40;
- 4) The diameter value of the inactive length depends on the process connection selected: Ø43: GGJ, RGJ, TDJ, MRJ; Flange: ASME B16.5: NPS ≥ 2", EN1092-1: ≥ DN50, JIS: ≥ 10K50
- 5) Probe tube

Weight

Housing with process connection:

- F15, F16, F17, F13 approximately 4.00 kg (8.82 lb)
- T13 approximately 4.50 kg (9.92 lb)
- F27 approximately 5.50 kg (10.1 lb)

Flange weight

Probe rope: 0.04 kg/m (0.03 lb/ft)

Measuring rope specifications**Capacitance values of the probe**

The basic capacitance of the probe is approximately 18 pF.

Additional capacitance

Mount the probe at a minimum distance of 50 mm (1.97 in) from a conductive container wall: approximately 1.0 pF/100 mm (3.94 in) in the air for a rope probe

Insulated probe rope in water:

approximately 19 pF/100 mm (3.94 in) in air

Materials

Material specifications as per AISI and DIN-EN.

In contact with the process

- Probe rope: 316L (1.4401)
- Probe rope insulation:
 - if FEP selected: FEP, PTFE and PFA (FDA 21 CFR 177.1550)
 - if PFA selected: PTFE and PFA (FDA 21 CFR 177.1550)
- Process connection: 316L (1.4435 or 1.4404)
- Flat seal for process connection G¾ or G1: elastomer fiber, asbestos-free
- Sealing ring for process connection G½, G¾, G1, G1½: elastomer fiber, asbestos-free, resistant to lubricants, solvents, steam, weak acids, and alkalis to 300 °C (572 °F) and to 100 bar (1450 psi)

Not in contact with the process

- ground terminals on housing (exterior): 304 (1.4301)
- the nameplate on housing (exterior): 304 (1.4301)
- cable glands:
 - housing F13, F15, F16, F17, F27: polyamide (PA) with C, D, E, F, H, M, J, P, S, 1, 4, 5 approval: nickel-plated brass
 - housing T13: nickel-plated brass

- polyester housing F16: PBT-FR with a cover made of PBT-FR or with sight glass made of PA12
 - cover seal: EPDM
 - adhesive nameplate: polyester foil (PET)
 - pressure compensation filter: PBT-GF20
- stainless steel housing F15: 316L (1.4404)
 - cover seal: silicone
 - cover clamp: 304 (1.4301)
 - pressure compensation filter: PBT-GF20, PA
- aluminum housing F17/F13/T13: EN-AC-ALSi10Mg, plastic-coated
 - cover seal: EPDM
 - cover clamp: nickel-plated brass
 - pressure compensation filter: silicone (not T13)
- stainless steel housing F27: 316L (1.4435)
 - cover seal: FVMQ, optional: EPDM seal available as a spare part
 - cover clamp: 316L (1.4435)

Operability

Operating concept

This device can operate with:

- the operating elements at the FEI50H or FEI57C electronic insert
- the display and operating module
- the HART protocol with Commubox FXA195 and FieldCare operating program
- the HART handheld terminal

Local operation

Electronic inserts

FEI50H (4 to 20 mA / HART version 5)

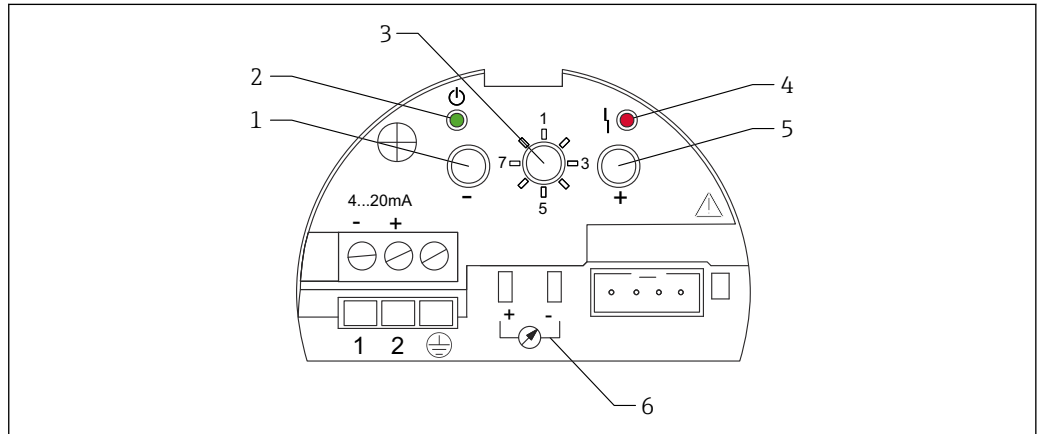

- 1 Key
- 2 Green LED - operational status
- 3 Mode switch
- 4 Red LED - fault
- 5 Key
- 6 Current pick-off 4 to 20 mA

Mode switch positions:

- 1: Operation
- 2: Empty adjustment
- 3: Full adjustment
- 4: Measuring modes - buildup
- 5: Measuring range
- 6: Self-test

7: Reset

8: Upload sensor EEPROM

FEI57C (PFM output)

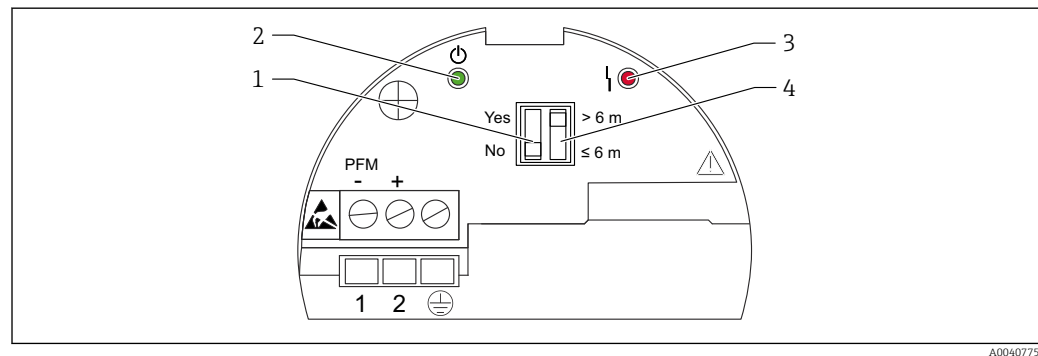

- 1 Two-position DIP switch "Build up"
 2 Green LED - operational status
 3 Red LED - fault
 4 Two-position DIP switch "Probe length"

Elements description

- Two-position DIP switch "Build up" (1):
 - YES: setting is recommended for media that cause heavy buildup, e.g. honey
 - NO: setting is recommended for media that do not cause buildup, e.g. water
- Green LED - operational status (2):
 - indicates that the device is ready for operation when flashes every 5 s
- Red LED - fault (3):
 - flashes 5x a second - Alarm.

The PFM output signalized an error current signal and sets the output of the connected switching unit to 3.6 mA or 22 mA. The switching unit outputs an alarm itself.

 - flashes 1x a second - Warning

The temperature in the electronic insert is outside the permitted temperature range.
- Two-position DIP switch "Probe length" (4):
 - probe length > 6 m (20 ft)
 - probe length ≤ 6 m (20 ft)

Local display

The optional display can be used to configure via 3 keys directly at the device. All device functions can be set via menu operation. The menu consists of function groups and functions. Application parameters can be read or set in the functions.

The menu guidance with integrated help texts ensures quick and safe commissioning. For accessing the display, the cover of the electronics compartment can also be opened in hazardous areas (Ex ia).

Remote operation

FieldCare Device Setup - the operating program

FieldCare is a graphic operating program for Endress+Hauser measuring devices based on the time-of-flight principle. It is used to support commissioning, data backup, signal analysis and documentation of the devices.

The following operating systems are supported:

- Windows 7 Professional SP1 (x32+x64)
- Windows 7 Ultimate SP1 (x32+x64)
- Windows 7 Enterprise SP1 (x32+x64)
- Windows Server 2008 R2 SP2
- Windows 8.1
- Windows 8.1 Professional
- Windows 8.1 Enterprise
- Windows 10 Professional
- Windows 10 Enterprise

FieldCare supports the following functions:

- configuration of transmitters in online operation
- tank linearization
- loading and saving device data (upload or download)
- documentation of the measuring point



Further information on FieldCare is provided on the CD-ROM which is supplied with the device.

FieldCare

Function scope

FDT-based plant asset management tool from Endress+Hauser. It can configure all smart field devices in a system and helps you manage them. By using the status information, it is also a simple but effective way of checking their status and condition.



For additional information about FieldCare, see Operating Instructions BA00027S and BA00059S





Connection options: HART via Commubox FXA195 and the USB port of a computer

Source for device description files

- www.endress.com → Downloads
- CD-ROM (contact Endress+Hauser)
- DVD (contact Endress+Hauser)

Certificates and approvals

CE mark	The measuring system meets the legal requirements of the applicable EC guidelines. These are listed in the corresponding EC Declaration of Conformity together with the standards applied. Endress+Hauser confirms successful testing of the device by affixing to it the CE mark.
RoHS	The measuring system complies with the substance restrictions of the Restriction on Hazardous Substances Directive 2011/65/EU (RoHS 2).
RCM-Tick marking	The supplied product or measuring system meets the ACMA (Australian Communications and Media Authority) requirements for network integrity, interoperability, performance characteristics as well as health and safety regulations. Here, especially the regulatory arrangements for electromagnetic compatibility are met. The products are labelled with the RCM- Tick marking on the name plate.
Ex approval	<ul style="list-style-type: none"> ■ ATEX ■ IECEX ■ CSA ■ FM ■ NEPSI ■ INMETRO ■ EAC <p>See "Ordering information" → 45.</p>
Hygienic compatibility	<p>Information regarding device versions that meet the requirements of 3A Sanitary Standard No. 74 and/or are certified by the EHEDG:</p> <p> SD02503F</p> <p> Suitable fittings and seals must be used to ensure hygiene-compliant design according to 3A and EHEDG specifications.</p> <p>Comply with the maximum permitted temperature of the process seal.</p> <p>The gap-free connections can be cleaned of all residue using the typical cleaning methods within this industry (CIP and SIP).</p>

EAC conformity	The measuring system meets the legal requirements of the applicable EAC guidelines. These are listed in the corresponding EAC Declaration of Conformity together with the standards applied. Endress+Hauser confirms successful testing of the device by affixing to it the EAC mark.
Other standards and guidelines	<p>EN 60529 Degrees of protection by housing (IP code)</p> <p>EN 61010 Protection measures for electrical equipment for measurement, control, regulation and laboratory procedures</p> <p>EN 61326 Interference emission (Class B equipment), interference immunity (Annex A - Industrial).</p> <p>NAMUR Association for Standards for Control and Regulation in the Chemical Industry</p> <p>IEC 61508 Functional safety</p>
CRN approval	Versions with a CRN approval (Canadian Registration Number) are listed in the corresponding registration documents. CRN-approved devices are labeled with registration number CRN OF1988.7C on the nameplate. You can find further details on the maximum pressure values in the "Download Area" of the Endress+Hauser website: www.endress.com .
Additional approvals	<p> The wetted device components are listed in:</p> <ul style="list-style-type: none"> ▪ "Mechanical construction" →  26 ▪ "Ordering information" →  45 <p>To find a list of all certificates go into the chapter "Certificates" →  46.</p> <p>AD2000 The wetted material (316L) corresponds to AD2000 – W0/W2.</p>
Pressure Equipment Directive 2014/68/EU	<p>Pressure equipment with allowable pressure ≤200 bar (2 900 psi)</p> <p>Pressure instruments with a flange and threaded boss that do not have a pressurized housing do not fall within the scope of the Pressure Equipment Directive, irrespective of the maximum allowable pressure.</p> <p>Reasons:</p> <p>According to Article 2, point 5 of EU Directive 2014/68/EU, pressure accessories are defined as "devices with an operational function and having pressure-bearing housings". If a pressure instrument does not have a pressure-bearing housing (no identifiable pressure chamber of its own), there is no pressure accessory present within the meaning of the Directive.</p>

Ordering information

Detailed ordering information is available from the following sources:

- In the *Product Configurator* on the Endress+Hauser website: www.endress.com -> click *Corporate* -> Select your country -> Click *Products* -> Select the product using the filter and search mask -> Open product page -> The *Configuration* button to the right of the product picture opens the Product Configurator.
- From your Endress+Hauser Sales Center: www.addresses.endress.com.



Product Configurator - the tool for individual product configuration

- Up-to-the-minute configuration data
- Depending on the device: Direct input of measuring point-specific information such as measuring range or operating language
- Automatic verification of exclusion criteria
- Automatic creation of the order code and its breakdown in PDF or Excel output format
- Ability to order directly in the Endress+Hauser Online Shop

Accessories

Protective cover

Protective cover for F13, F17 and F27 housing

order number: 71040497

Protective cover for F16 housing

order number: 71127760

Commubox FXA195 HART

For intrinsically safe HART communication with FieldCare via the RS232C interface or USB.

Surge arresters

HAW562



- For supply lines: BA00302K.
- For signal lines: BA00303K.

HAW569



- For signal lines in field housing: BA00304K.
 - For signal or supply lines in field housing: BA00305K.
-

Weld-in adapter

All available weld-in adapters are described in the document TI00426F.

The documentation is available in the Download section on Endress+Hauser web site: www.endress.com

Documentation

Technical Information	Fieldgate FXA320, FXA520 TI00025S
Operating Instructions	Liquicap M FMI52 HART BA02021F Liquicap M FMI52 PFM BA01986F
Certificates	<p>ATEX safety instructions Liquicap M FMI52</p> <ul style="list-style-type: none"> ▪ II 1/2 G Ex ia IIC T3...T6 Ga/Gb II 1/2 G Ex ia IIB T3...T6 Ga/Gb II 1/2 D Ex ia IIIC T90 °C Da/Db XA00327F ▪ II 1/2 Ex ia/db IIC T6...T3 Ga/Gb II 1/2 Ex ia/db eb IIC T6...T3 Ga/Gb II 1/2 D Ex ia /tb IIIC T90 °C Da/Db XA00328F ▪ Ga/Gb Ex ia IIC T3...T6 Zone 20/21 Ex iaD 20/Ex tD A21 IP65 T 90 °C IECEx BVS 08.0027X XA00423F ▪ II 3 G Ex nA IIC T6 Gc II 3 G Ex nA nC IIC T5 Gc II 3C D Ex tc IIIC T100 °C Dc XA00346F <p>INMETRO safety instructions Liquicap M FMI52</p> <ul style="list-style-type: none"> ▪ Ex d [ia Ga] IIB T3...T6 Ga/Gb Ex d [ia Ga] IIC T3...T6 Ga/Gb Ex de [ia Ga] IIC T3...T6 Ga/Gb XA01171F ▪ Ex ia IIC T* Ga/Gb Ex ia IIB T* Ga/Gb Ex ia IIIC T90 °C Da/Db IP66 XA01172F <p>NEPSI safety instructions</p> <ul style="list-style-type: none"> ▪ Liquicap M FMI52 Ex ia IIC/IIB T3...T6 Ga/Gb XA00417F ▪ Liquicap M FMI52 Ex d ia IIC/IIB T3/T4/T6 Ga/Gb Ex d e ia IIC/IIB T3/T4/T6 Ga/Gb XA00418F ▪ Liquicap M FMI52 Ex nA IIC T3...T6 Gc Ex nA nC IIC T3...T6 Gc XA00430F <p>Overfill protection DIBt (WHG) Liquicap M FMI52 ZE00265F</p> <p>Functional safety (SIL2) Liquicap M FMI52 SD00198F</p>

Control Drawings (CSA and FM)

- Liquicap M FMI52
FM IS
ZD00220F
- Liquicap M FMI52
CSA IS
ZD00221F
- Liquicap M FMI52
CSA XP
ZD00233F



71510164

www.addresses.endress.com
