



User Manual

EE160

Humidity and Temperature Sensor for Building Automation



YOUR PARTNER IN SENSOR TECHNOLOGY



ELEKTRONIK[®]
Ges.m.b.H.

E+E Elektronik Ges.m.b.H. does not accept warranty and liability claims neither upon this publication nor in case of improper treatment of the described products.

The document may contain technical inaccuracies and typographical errors. The content will be revised on a regular basis. These changes will be implemented in later versions. The described products can be improved and changed at any time without prior notice.

© Copyright E+E Elektronik Ges.m.b.H. All rights reserved.

EMC note USA (FCC):

This equipment has been tested and found to comply with the limits for a Class A digital device, pursuant to part 15 of the FCC Rules. These limits are designed to provide reasonable protection against harmful interference when the equipment is operated in a commercial environment. This equipment generates, uses, and can radiate radio frequency energy and, if not installed and used in accordance with the instruction manual, may cause harmful interference to radio communications. Operation of this equipment in a residential area is likely to cause harmful interference in which case the user will be required to correct the interference at his own expense.

EMC note Canada (ICES-003):

CAN ICES-3 (A) / NMB-3 (A)

CONTENT

1	General	4
1.1	Explanation of Symbols	4
1.2	Safety Instructions	4
1.2.1	General Safety Instructions	4
1.2.2	Intended Use	4
1.2.3	Mounting, Start-up and Operation	5
1.3	Environmental Aspects	5
2	Scope of Supply	5
3	Product Description	6
3.1	General	6
3.2	Dimensions	6
3.3	Electrical Connection	6
4	Setup and Adjustment	8
4.1	Product Configuration Adapter and Software for EE160 with legacy Sensing Element	8
4.2	Product Configuration Adapter and Software for EE160 with new Sensing Element	10
4.3	PCS10 Product Configuration Software	12
4.4	Address Setting	12
4.5	BACnet Setup	13
4.6	Digital Interface RS485 with Modbus RTU Protocol	13
4.7	Modbus Register Map	14
4.8	Modbus Message Example	14
5	RH / T Adjustment and Calibration	15
6	Accessories	15
7	Technical Data	16

1 General

This user manual serves for ensuring proper handling and optimal functioning of the device. The user manual shall be read before commissioning the equipment and it shall be provided to all staff involved in transport, installation, operation, maintenance and repair. The user manual may not be used for the purposes of competition without the written consent of E+E Elektronik® and may not be forwarded to third parties. Copies may be made for internal purposes. All information, technical data and diagrams included in these instructions are based on the information available at the time of writing.

Disclaimer

The manufacturer or his authorized agent can be only be held liable in case of willful or gross negligence. In any case, the scope of liability is limited to the corresponding amount of the order issued to the manufacturer. The manufacturer assumes no liability for damages incurred due to failure to comply with the applicable regulations, operating instructions or the specified operating conditions. Consequential damages are excluded from the liability.



Please find this document and further product information on our website at www.epluse.com/ee160.

1.1 Explanation of Symbols



This symbol indicates safety information.

It is essential that all safety information is strictly observed. Failure to comply with this information can lead to personal injuries or damage to property. E+E Elektronik® assumes no liability if this happens.



This symbol indicates instructions.

The instructions shall be observed in order to reach optimal performance of the device.

1.2 Safety Instructions

1.2.1 General Safety Instructions



- The device and mainly the filter cap shall not be exposed to unnecessary mechanical stress.
- When replacing the filter cap make sure not to touch the sensing elements.
- The device must be operated with the filter cap on at all times.
- Installation, electrical connection, maintenance and commissioning shall be performed by qualified personnel only.
- Use the EE160 only as intended and observe all technical specifications.
- Do not use EE160 in explosive atmosphere or for measurement of aggressive gases.
- Do not apply the nominal voltage to the RS485 data lines.
- This device is not appropriate for safety, emergency stop or other critical applications where device malfunction or failure could cause injury to human beings.

1.2.2 Intended Use

The EE160 is intended for the humidity (RH) and temperature (T) measurement in building automation.

The use of the EE160 in any other way than described in this manual bears a safety risk for people and the entire measurement installation and is therefore not allowed. The manufacturer cannot be held responsible for damages as a result of incorrect handling, installation, and maintenance of the equipment.



Please note:

For accurate measurement it is essential that the temperature of the sensing probe and mainly of the sensing head is same as the temperature of the air to measure. Avoid mounting the EE160 sensor in a way which creates temperature gradients along the probe.

In order to avoid damage to the instrument or health hazards, the measuring equipment must never be manipulated with tools that are not specifically described in this manual.

The sensor may only be utilized in accordance with the conditions defined in the technical data. Otherwise, measurement inaccuracies will occur and equipment failures cannot be ruled out.

The steps recommended by the manufacturer for installation, inspections and maintenance work must be observed and carried out for the safety of the user and for the functionality of the equipment.

Unauthorized product modification leads to loss of all warranty claims. This may be accomplished only with an explicit permission of E+E Elektronik®!

1.2.3 Mounting, Start-up and Operation

The EE160 humidity and temperature sensor has been produced under state of the art manufacturing conditions, has been thoroughly tested and has left the factory after fulfilling all safety criteria. The manufacturer has taken all precautions to ensure safe operation of the device. The user must ensure that the device is set up and installed in a manner that does not have a negative effect on its safe use. The user is responsible for observing all applicable safety guidelines, local and international, with respect to safe installation and operation on the device. This user manual contains information and warnings that must be observed by the user in order to ensure safe operation.



- Mounting, start-up, operation and maintenance of the device may be performed by qualified staff only. Such staff must be authorized by the operator of the facility to carry out the mentioned activities.
- The qualified staff must have read and understood this user manual and must follow the instructions contained within.
- All process and electrical connections shall be thoroughly checked by authorized staff before putting the device into operation.
- Do not install or start-up a device supposed to be faulty. Make sure that such devices are not accidentally used by marking them clearly as faulty.
- A faulty device may only be investigated and possibly repaired by qualified, trained and authorized staff. If the fault cannot be fixed, the device shall be removed from the process.
- Service operations other than described in this user manual may only be performed by the manufacturer.

1.3 Environmental Aspects



Products from E+E Elektronik® are developed and manufactured in compliance with all relevant environmental protection requirements. Please observe local regulations for the device disposal.



For disposal, the individual components of the device must be separated according to local recycling regulations. The electronics shall be disposed of correctly as electronics waste.

2 Scope of Supply

Model	EE160 Wall mount (Type T1)	EE160 Duct mount (Type T2)	Additionally for all EE160 with RS485 interface
EE160 Humidity and Temperature Sensor according to order code	✓	✓	
Cable gland	✓	✓	✓
Mounting kit	✓	✓	
Mounting flange		✓	
Inspection certificate according to DIN EN 10204-3.1	✓	✓	
Quick Guide - EE160 RS485 Setup			✓

3 Product Description

3.1 General

The EE160 sensor is optimized for cost effective, accurate measurement of relative humidity (RH) and temperature (T) in building automation.

The measured data is available on

- two voltage or current (2-wire) outputs
- the RS485 interface with BACnet MS/TP or Modbus RTU protocol
- a passive T output

Both, the wall mount and the duct mount model come with an IP65 / NEMA 4X enclosure which provides minimal installation costs and reliable protection against contamination and condensation. The encapsulated electronics in the probe and the E+E sensor coating ensure long-term stable and accurate measurements.

The user can set the RS485 interface parameters, the output scaling and perform 1- or 2-point adjustment for RH and T with an optional configuration adapter and the free PCS10 Product Configuration Software.

3.2 Dimensions

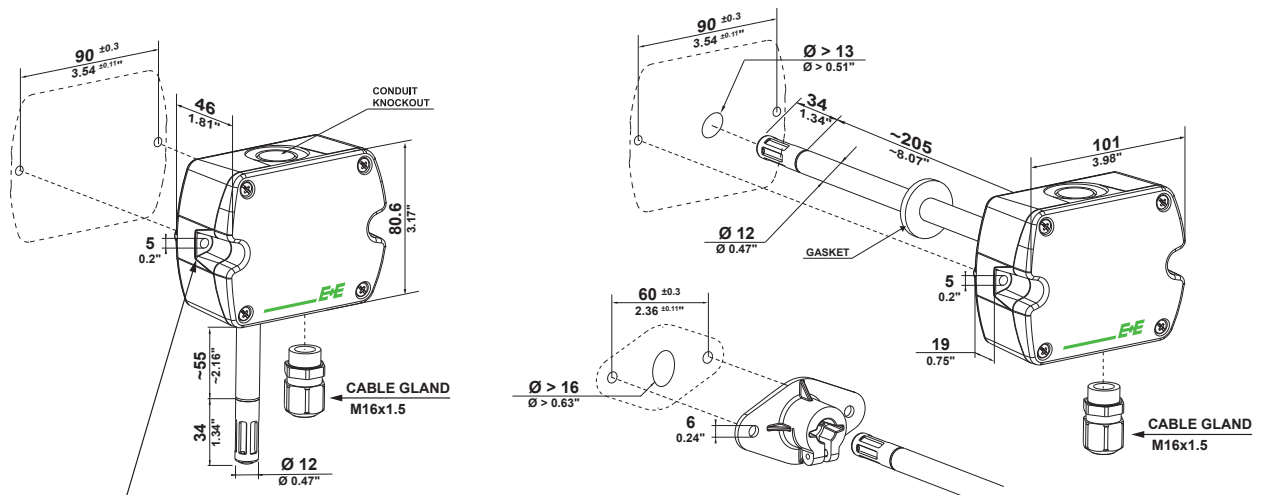

Recommended mounting screws:
ST4.2x50 DIN7981C

Fig. 1 Dimensions of EE160 in mm and inch

3.3 Electrical Connection



Important note:

The manufacturer cannot be held responsible for personal injuries or damage to property as a result of incorrect handling, installation, wiring, power supply and maintenance of the device.

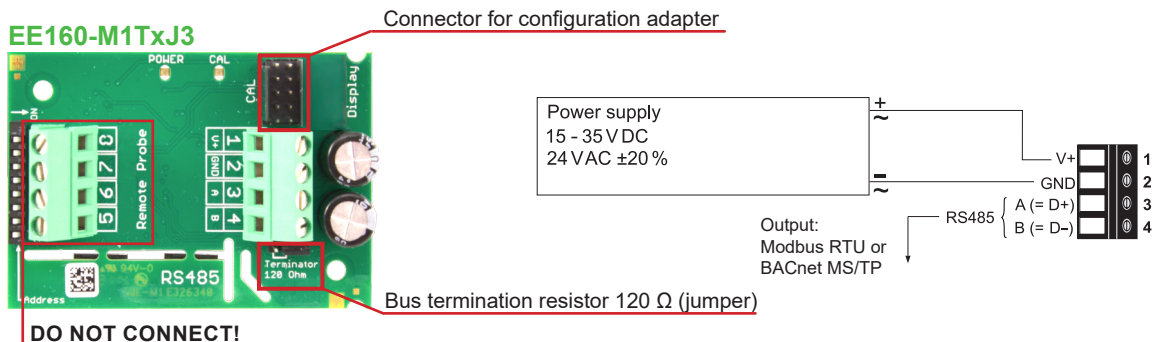



Bus Termination:

If required, the RS485 bus termination can be realized with 120 Ω resistor, jumper on the board.

EE160-MxTxA3

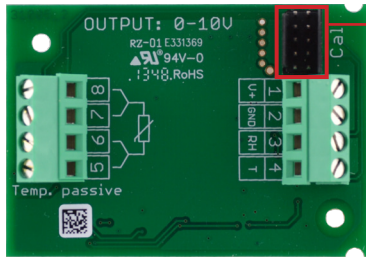

Connector for configuration adapter

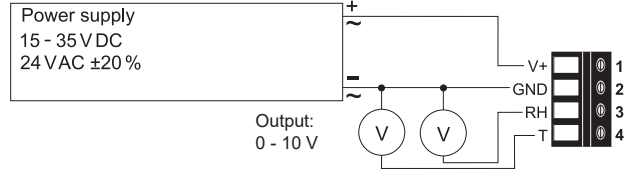

T-passive connection for M8TxA3/M8TxA6

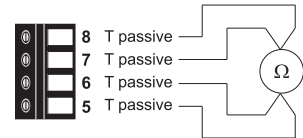

EE160-MxTxA6

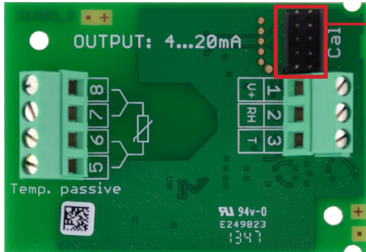

Connector for configuration adapter

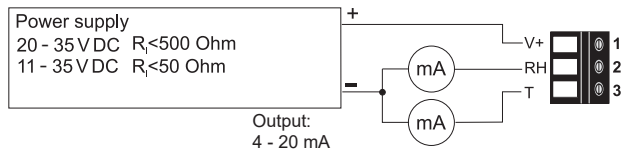

LED indication for EE160-M1TxJ3:

Green LED - information on normal operation mode:

- on = everything OK
- flashing = the main board does not recognize the measurement electronics inside the sensing probe
- off = no power supply or main board failure

Blue LED - information during setup with PCS10 Product Configuration Software and the configuration adapter:

- on = adapter connected to EE160 and PC, no communication with PCS10
- flashing = communication in progress with PCS10
- off = adapter not connected to EE160 and PC

4 Setup and Adjustment

The EE160 is ready to use and does not require any configuration by the user. The factory setup of EE160 corresponds to the type number ordered. Please refer to the data sheet at www.epluse.com/ee160. The user can change the factory setup with the help of the Product Configuration Software and the USB configuration adapter.

Besides the output scaling the user can change the communication settings for digital interface and perform one or two point adjustment for humidity and temperature.

4.1 Product Configuration Adapter and Software for EE160 with legacy Sensing Element

Remove the filter cap and check the sensing element of your EE160.



If the EE160 is equipped with a legacy sensing element according to the picture above, it must only be configured or adjusted using the EE-PCS Product Configuration Software (free download from www.epluse.com/configurator) and the adapters according to the following table:

Version	EE160 legacy sensing element	
	Configuration adapter	Configuration software
EE160-MxTxA3 Analogue voltage 0...10 V	EE-PCA + HA011059	EE-PCS
EE160-MxTxA6 Analogue current 4...20 mA	EE-PCA + HA011059	EE-PCS
EE160-M1TxJ3 Digital RS485 Modbus/BACnet	HA011066	EE-PCS

EE160-MxTxAx (analogue output)

Using the EE-PCA Product Configuration Adapter with cable and the EE-PCS Product Configuration Software.

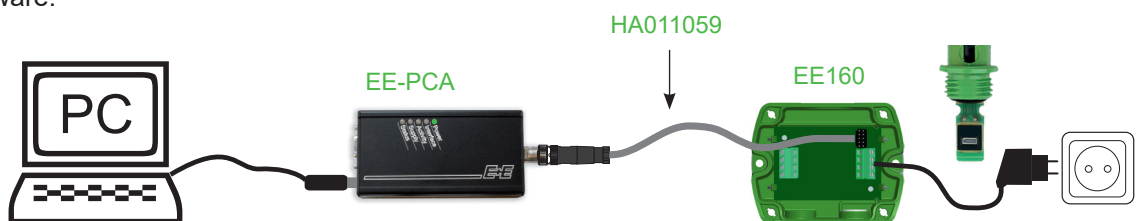

Please note: The EE160 must be powered when using the EE-PCA kit.

EE-PCS Product Configuration Software for analogue version.



EE160-M1TxJ3 (digital interface)

Using the USB configuration adapter HA011066 and the EE-PCS Product Configuration Software.

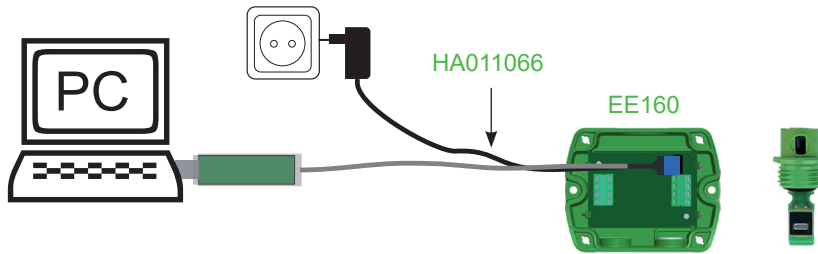

Please note: The EE160 may not be connected to any additional power supply when using the USB configuration adapter.

EE-PCS Product Configuration Software for digital version.



4.2 Product Configuration Adapter and Software for EE160 with new Sensing Element

Remove the filter cap and check the sensing element of your EE160.



If the EE160 is equipped with a new sensing element according to the picture above it must only be configured or adjusted using the PCS10 Product Configuration Software (free download from www.epluse.com/PCS10) and the adapters according to the following table:

Version	EE160 new sensing element	
	Configuration adapter	Configuration software
EE160-MxTxA3 Analogue voltage 0...10 V	HA011069 (connector voltage)	PCS10
EE160-MxTxA6 Analogue current 4...20 mA	HA011069 (connector current)	PCS10
EE160-M1TxJ3 Digital RS485 Modbus/BACnet	HA011066	PCS10

The USB configuration adapter HA011069 features two connectors for configuring either an EE160-MxTxA6 (current version) or an EE160-MxTxA3 (voltage version). See the picture below:

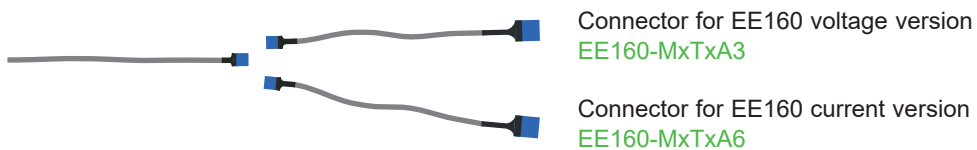

EE160-MxTxAx (analogue output)

Using the USB configuration adapter HA011069 and the PCS10 Product Configuration Software.

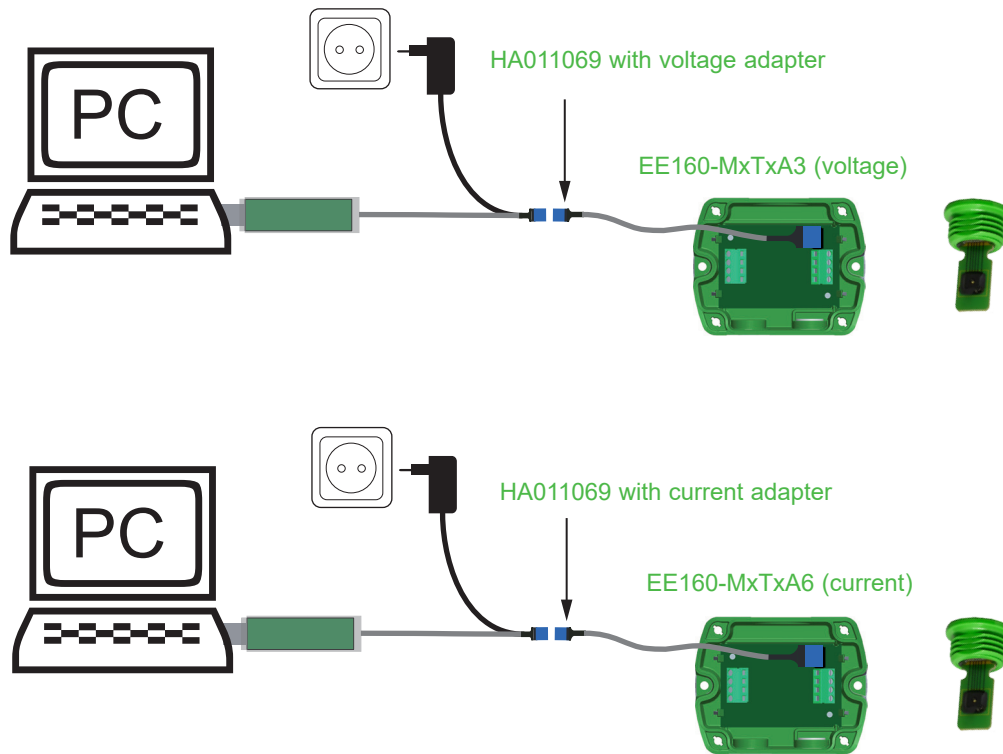

Please note: The EE160 may not be connected to any additional power supply when using the USB configuration adapter.

PCS10 Product Configuration Software for analogue version

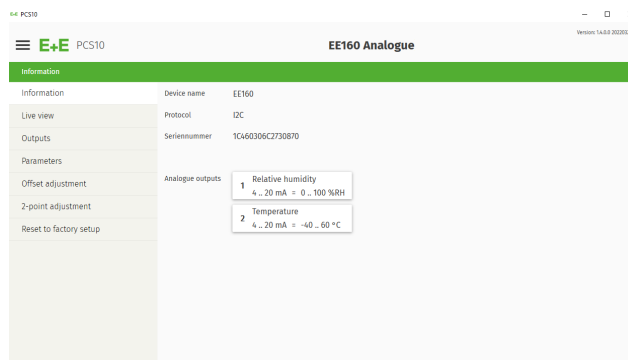

EE160-M1TxJ3 (digital interface)

Using the USB configuration adapter HA011066 and the PCS10 Product Configuration Software.

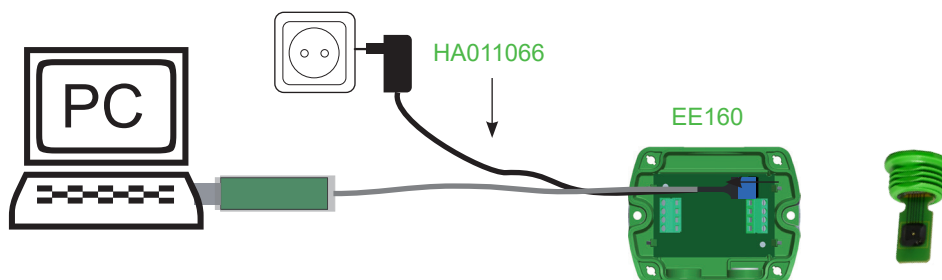



Please note: The EE160 may not be connected to any additional power supply when using the USB configuration adapter.

PCS10 Product Configuration Software for digital version

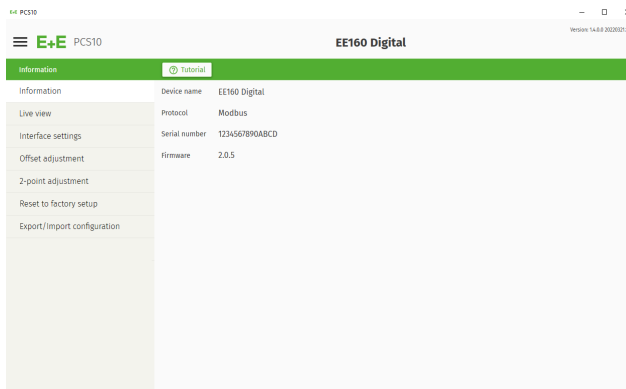

4.3 PCS10 Product Configuration Software

To use the software for performing adjustments and changes in settings, please proceed as follows:

1. Download the PCS10 Product Configuration Software from www.epluse.com/pcs10 and install it on the PC.
2. Connect the EE160 to the PC using the USB configuration adapter:
3. Start the PCS10 software.
4. Follow the instructions on the PCS10 opening page for scanning the ports and identifying the connected device.
5. Click on the desired setup or adjustment mode from the main PCS10 menu on the left and follow the online instructions of the PCS10.

4.4 Address Setting

Address Switch

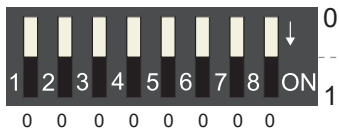

Address setting via PCS10 Product Configuration Software:

All DIP switches at position 0 → address has to be set via PCS10

Modbus (Slave device): factory setting EE160: 245 (permitted values: 1...247).

BACnet (Master device): factory setting EE160: 2 (permitted values: 0...127).

Example: Address is set via configuration software.

Address Switch

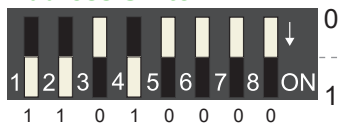

Address setting via DIP switch:

Modbus (Slave device): Setting the DIP switch to any other address than 0, overrules the Modbus address set via configuration software (permitted values: 1...247).

BACnet (Master device): Setting the DIP switch to any other address than 0, overrules the BACnet address set via configuration software.

BACnet Note: permitted values are 0...127. The 8th bit of the DIP switch is ignored (ID 127 = 0111 1111).

To set address 0 via DIP switch, the 8th bit shall be set to 1 (ID 0 = 1000 0000).

Example: Address set to 11 (= 0000 1011 binary).

4.5 BACnet Setup

BACnet PICS is available for download at www.epluse.com/ee160.

4.6 Digital Interface RS485 with Modbus RTU Protocol

Item	Factory settings	Selectable values (via PCS10)
Baud rate	9 600	9 600, 19 200, 38 400, 57 600, 76 800, 115 200
Data bits	8	8
Parity	Even	None, odd, even
Stop bits	1	1, 2
Modbus address	245	1...247

Tab. 1 Digital interface default settings

The recommended settings for multiple devices in a Modbus RTU network are 9600, 8, even, 1. The EE160 represents 1 unit load on an RS485 network.

Device address, baud rate, parity and stop bits can be set via:

1. PCS10 Product Configuration Software, the USB configuration adapter HA011066.
The PCS10 can be downloaded free of charge from www.epluse.com/pcs10
2. Modbus protocol in the register 60001 (0x00) and 60002 (0x01).
See Modbus Application Note AN0103 (available at www.epluse.com/ee160)

The serial number as ASCII-code is located in the register addresses 0x00...0x07 (16 bits per address). The firmware version is located in the register address 0x08 (bits 15...8 = major release; bits 7...0 = minor release). The sensor name is located in register address 0x09. The beforementioned registers can be read out with function code 0x03 or 0x04.



Please note: When reading the serial number or the sensor name, it is always necessary to read all 8 registers, even if the desired information requires less.



Please note: For obtaining the correct floating point values, both registers have to be read within the same reading cycle. The measured value can change between two Modbus requests, therefore, exponent and mantissa may get inconsistent.

Communication settings (INT16)		
Parameter	Register number ¹⁾ [DEC]	Protocol address ²⁾ [HEX]
Write register: function code 0x06		
Modbus address	1	0x00
Modbus protocol settings ³⁾	2	0x01

1) Register number starts from 1.

2) Protocol address starts from 0.

3) For Modbus protocol settings see Application Note Modbus AN0103 (available at www.epluse.com/ee160).

INFO (read register)		
Parameter	Register number ¹⁾ [DEC]	Protocol address ²⁾ [HEX]
Read register: function code 0x03 / 0x04		
Serial number (as ASCII)	1	0x00
Firmware version	9	0x08
Sensor Name	10	0x09

1) Register number starts from 1.

2) Protocol address starts from 0.

4.7 Modbus Register Map

The measured data is saved as a 32 bit floating point values (data type FLOAT) and as 16 bit signed integer values (data type INTEGER).

FLOAT32:			
Parameter	Unit	Register number ¹⁾ [Dec]	Register address ²⁾ [HEX]
<i>Read register: function code 0x03</i>			
Temperature T	°C, °F ³⁾	26	0x19
Relative humidity RH, Uw	% RH	28	0x1B

1) Register number starts from 1.

2) Register address starts from 0.

3) The choice of measurement units (metric or non-metric) is done at the time of ordering, see the ordering guide in the EE160 data sheet. It is not possible to switch from metric to non-metric or vice versa by means of the PCS10.

INT16:				
Parameter	Unit	Scale ¹⁾	Register number ²⁾ [Dec]	Register address ³⁾ [HEX]
<i>Read register: function code 0x03</i>				
Temperature T	°C, °F ⁴⁾	100	301	0x12C
Relative humidity RH, Uw	% RH	100	302	0x12D

1) Example: For scale 100, the reading of 2550 means a value of 25.5.

2) Register number starts from 1.

3) Register address starts from 0.

4) The choice of measurement units (metric or non-metric) is done at the time of ordering, see the ordering guide in the EE160 data sheet. It is not possible to switch from metric to non-metric or vice versa by means of the PCS10.

4.8 Modbus Message Example

Example of Modbus RTU command for reading the temperature (float value) T = 23,290008 °C from the register 0x19.

Device EE160; Modbus address 245 [0xF5]

Reference document, chapter 6.3: www.modbus.org/docs/Modbus_Application_Protocol_V1_1b3.pdf

See Application Note Modbus AN0103 (available at www.epluse.com/ee160)

	Modbus address	Function code	Starting address Hi	Starting address Lo	No. of register Hi	No. of register Lo	CRC	
Request [Hex]:	F5	03	00	19	00	02	01	0F

	Modbus address	Function code	Byte count	Register 1 value Hi	Register 1 value Lo	Register 2 value Hi	Register 2 value Lo	CRC	
Response Hex]:	F5	03	04	51	F0	41	BA	98	10

Decoding of floating point values:

Floating point values are stored according to IEEE754. The byte pairs 1, 2 and 3, 4 are transformed as follows (numbers taken from T reading Modbus request/response example above):

Modbus response [Hex]			
Byte 3	Byte 4	Byte 1	Byte 2
51	F0	41	BA
MMMMMMMM	MMMMMMMM	SEEEEEEE	EMMMMMMM

IEEE754			
Byte 1	Byte 2	Byte 3	Byte 4
41	BA	51	F0
0100 0001	1011 1010	0101 0001	1111 0000
SEEE EEEE	EMMM MMMM	MMMM MMMM	MMMM MMMM
Decimal value: 23.290008			

5 RH / T Adjustment and Calibration

Definitions

- **Calibration** documents the accuracy of a measurement device. The device under test (specimen) is compared with the reference and the deviations are documented in a calibration certificate. During the calibration, the specimen is not changed or improved in any way.
- **Adjustment** improves the measurement accuracy of a device. The specimen is compared with the reference and brought in line with it. An adjustment can be followed by a calibration which documents the accuracy of the adjusted specimen.

Depending on the application and the requirements of certain industries, there might arise the need for periodical humidity calibration (comparison with a reference) or adjustment (bringing the device in line with a reference).

- Calibration and adjustment at E+E Elektronik
Calibration and/or adjustment can be performed in the E+E Elektronik calibration laboratory. For information on the E+E capabilities in ISO or accredited calibration refer to www.eplusecal.com.
- Calibration and adjustment by the user
Depending on the level of accuracy required, the humidity reference can be:
 - Humor 20 Humidity Calibrator, refer to www.epluse.com.
 - Omniport30 handheld device, refer to www.epluse.com/omniport30.
 - Certified salt solutions, refer to www.epluse.com/ee160.

Cleaning of the sensing head:

Use in polluted environment might rise the need for cleaning the sensing head and replacing the filter cap. In such a case refer to “Cleaning Instructions” at www.epluse.com/ee160.

When employed in dusty, polluted environment:

- The filter cap shall be replaced once in a while with an E+E original one. A polluted filter cap causes longer response time of the device.
- If needed, the sensing head can be cleaned. For cleaning instructions refer to www.epluse.com/ee160.



Please note: While replacing the filter cap take very good care to not touch or rub the sensing element.

6 Accessories

Please also refer to the “[Accessories](#)“ data sheet.

Description	Order code
E+E Product Configuration Software (Free download: www.epluse.com/pcs10)	PCS10
Power supply adapter	V03
Protection cap for 12 mm probe	HA010783
USB configuration adapter for EE160-M1TxJ3 (digital)	HA011066
USB configuration adapter for EE160-MxTxAx (analogue)	HA011069

EE160 configuration with legacy sensing element (see chapter 4.1)	Order code
E+E Product Configuration Software (Free download: www.epluse.com/configurator)	EE-PCS
USB configuration adapter for EE160-M1TxJ3 (digital)	HA011066
Product configuration adapter for EE160-MxTxAx (analogue)	see datasheet EE-PCA

7 Technical Data

Measurands

Relative Humidity (RH)

Measuring range	0...100 %RH, non-condensing		
Accuracy ¹⁾	23 °C (0...100 %RH)	±2.5 %RH	
	0...+40 °C (0...100 %RH)	±3 %RH	
	-20...+60 °C (0...100 %RH)	±4 %RH	
	-40...-20 °C (0...100 %RH)	±5 %RH	

1) Traceable to international standards, administrated by NIST, PTB, BEV,...

The accuracy statement includes the uncertainty of the factory calibration with an enhancement factor k=2 (2-times standard deviation). The accuracy was calculated in accordance with EA-4/02 and with regard to GUM (Guide to the Expression of Uncertainty in Measurement).

Temperature (T)

Measuring range	-40...+60 °C (-40...+140 °F)
Accuracy	<p>The graph plots accuracy (±ΔT [°C]) on the y-axis (0 to 0.6) against temperature (T [°C]) on the x-axis (-40 to 60). The accuracy curve starts at 0.6°C at -40°C, decreases to 0.3°C at 23°C, and then increases to 0.5°C at 60°C.</p>

Outputs

Analogue

RH: 0...100 %, T: see ordering guide	4 - 20 mA (2-wire) 0 - 10 V	$R_L \leq 500 \Omega$ $0 \text{ mA} < I_L < 1 \text{ mA}$	$R_L = \text{load resistance}$ $I_L = \text{load current}$
--------------------------------------	--------------------------------	--	---



T Sensor Passive

Type acc. to ordering code	4-wire connection
----------------------------	-------------------

Digital

Digital interface	RS485 (EE160 = 1 unit load)
Protocol	Modbus RTU
Factory settings	Baud rate acc. to ordering code, parity even, 1 stop bit, Modbus address 245
Supported baud rates	9 600, 19 200 and 38 400
Data types for measured values	FLOAT32 and INT16
Protocol	BACnet MS/TP
Factory settings	Baud rate acc. to ordering code, parity none, 1 stop bit, BACnet address 2
Supported baud rates	9 600, 19 200, 38 400, 57 600, 76 800 and 115 200

General

Power supply class III  USA & Canada: Class 2 supply necessary, max. voltage 30 V DC	4 - 20 mA (2-wire)	$(10\text{ V} + R_L * 20\text{ mA}) < V+ < 35\text{ V DC}$		
	0 - 10 V RS485	15 - 35 V DC or 24 V AC $\pm 20\%$		
Current consumption, typ.		4 - 20 mA output	0 - 10 V output	RS485
	24 V DC supply	max. 40 mA	5 mA	5 mA
	24 V AC supply	-	13 mA _{rms}	15 mA _{rms}
Electrical connection	Screw terminals max. 1.5 mm ² (AWG 16)			
Cable gland	M16x1.5			
Storage conditions	-40...+60 °C (-40...+140 °F)			
Enclosure	Material Protection rating	Polycarbonate (PC), UL94 V-0 approved IP65/NEMA 4X		
Electromagnetic compatibility	EN 61326-1 FCC Part15 ClassA	EN 61326-2-3 ICES-003 ClassA	Industrial environment	
Conformity	EN 45545-2 (HL3)			



HEADQUARTERS

E+E Elektronik Ges.m.b.H.

Langwiesen 7
4209 Engerwitzdorf
Austria
Tel.: +43 7235 605-0
E-mail: info@epluse.com
Web: www.epluse.com

SUBSIDIARIES

E+E Elektronik China

18F, Kaidi Financial Building,
No.1088 XiangYin Road
200433 Shanghai
Tel.: +86 21 6117 6129
E-mail: info@epluse.cn

E+E Elektronik France

47 Avenue de l'Europe
92310 Sèvres
Tel.: +33 4 74 72 35 82
E-mail: info@epluse.fr

E+E Elektronik Germany

Obere Zeil 2
61440 Oberursel
Tel.: +49 6171 69411-0
E-mail: info@epluse.de

E+E Elektronik India

801, Sakhi Vihar Road
400072 Mumbai
Tel.: +91 990 440 5400
E-mail: info.in@epluse.com

E+E Elektronik Italy

Via Alghero 17/19
20128 Milano (MI)
Tel.: +39 02 2707 86 36
E-mail: info@epluse.it

E+E Elektronik Korea

Suite 2001, Heungdeok IT
Valley Towerdong, 13,
Heungdeok 1-ro, Giheung-gu
16954 Yongin-si, Gyeonggi-do
Tel.: +82 31 732 6050
E-mail: info@epluse.co.kr

E+E Elektronik USA

333 East State Parkway
Schaumburg, IL 60173
Tel.: +1 847 490 0520
E-mail: office@epluse.com