

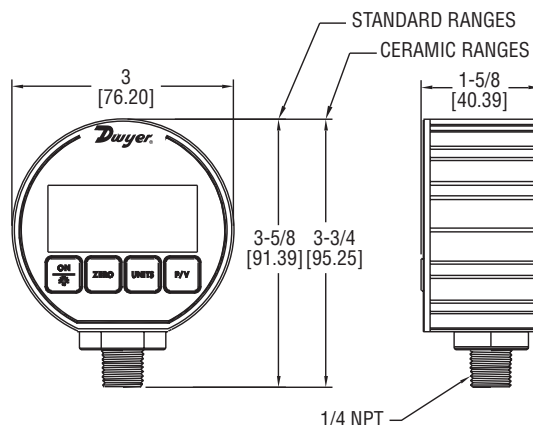

Series DPG-100 Digital Pressure Gauge

Specifications - Installation and Operating Instructions



The Series DPG-100 Digital Pressure Gauge has a precise +/- 0.25% full scale accuracy. The 4 digit digital display will reduce the potential for errors in readings by eliminating parallax error commonly produced with analog gauges.

The DPG-100 is packaged in a durable extruded aluminum case designed to meet NEMA 4/4X. The unit is battery powered and has an auto-shut off to conserve battery life. A four button key pad allows easy access to features without the need to work through complex menus or difficult key combinations. These features include backlight, peak and valley, auto zero and conversion of the pressure units. Readings may be converted to various engineering units. See reverse page for available units.

DPG Quick Start Button Operation

For complete detailed instructions on the four button operation see the Operation Chart provided on back.



On/Backlight: Push to turn on; Press again for backlight. Press and hold for 5 seconds to turn unit off.



Zero: Zeros the display - Push & hold for 2 seconds to zero the display. If after pressing zero the display does not re-zero, the unit is no longer meeting specified accuracy and should be sent back to the factory for calibration. **Do not use the zero button when pressure is applied.**



Units: Scroll (see next page for Model/Range Chart).



P/V: Peak recorded reading retrieved by initial push of button; push again retrieves the valley or lowest value recorded.

INSTALLATION

When installing gauge always use 1" hex at the base of the housing to tighten the gauge to a mating fitting. **Do not apply wrench to housing.**

MAINTENANCE

A "LOW BAT" descriptor indication will appear on the display when batteries need to be replaced.

Battery Replacement: Remove the three screws on backplate. Lift backplate off by hand. Replace batteries per polarity indicators. To reassemble, ensure O-Ring seats into housing evenly and press until seated completely. Replace screws.

WARNING: Substitution of components may impair intrinsic safety. Batteries must be changed in a non-hazardous location only. **DO NOT** mix batteries from different manufacturers. **DO NOT** mix old batteries with new batteries.

Service: Liquids and combustible compatible gases (for FM listings see agency approvals below).

Wetted Materials: Type 316L SS.

Housing Materials: Black polycarbonate front & back cover, anodized aluminum extruded housing with recessed grooves, polycarbonate overlay, Buna-N O-Rings, 316L SS sensor construction.

Accuracy: 0.25% full scale; Ceramic Ranges: 0.5% full scale; ± 1 least significant digit @ 70°F (21°C). (Includes linearity, hysteresis, repeatability).

Pressure Limit: 2x pressure range for models ≤1000 psi; 5000 psi for 3000 psi range; 7500 psi for 5000 psi range.

Enclosure Rating: Designed to meet NEMA 4/4X (IP65).

Temperature Limits: 0 to 130°F

(-18 to 55°C).

Thermal Effect: Between 70 to 130°F is 0.016%/F; Between 32 to 70°F is 0.026%/F; Between 10 to 32°F is 0.09%/F; Between 0 to 10°F is 0.50%/F.

Size: 3.00" OD x 1.90 deep (max).

Process Connection: 1/4" male NPT.

Weight: 8.84 oz (275 g).

Display: 4 digit (.425 H x .234W digits).

Sample Rate: 2 sec.

Power Requirements: (2) AAA alkaline batteries, included, user replaceable.

Battery Life: 2000 hours typi-cal; low battery indicator.

Auto Shut-Off: Gauge: 60 minute auto shut-off. Auto shut-off may be disengaged; Backlight: 2 minute auto shut-off.

Agency Approvals: FM approved to be intrinsically safe for Class I, Division I, Groups A,B, C and D, for ranges 0-15 to 0-3000 psi. CE EMC Directive:

EN 61000-4-2

EN 61000-4-3 & ENV50204

EN 61000-6-2

EN 61000-6-4

EN 55011.

*Note: Gauges with ceramic sensor are not CE and FM approved.

WARNING: DO NOT pressurize DPG over maximum allowable pressure limits. Extreme damage can occur if limits are exceeded (see Pressure Limit under Specifications). An overflow "OFL" designator will flash to acknowledge that the gauge's pressure range has been exceeded.

PANEL MOUNT OPTION

Drill a 3-1/4" (82.55) diameter hole in a panel, locate three mounting holes for a #6 screw 120° apart on a 3-5/8" (92.08) bolt circle.

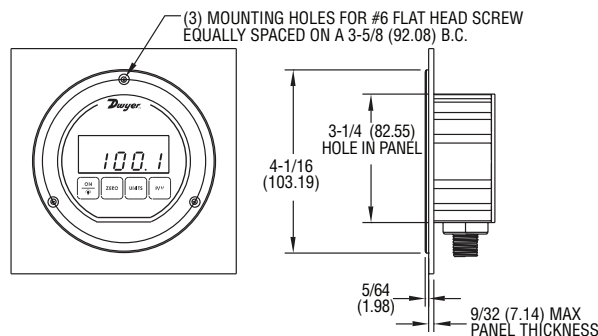

DPG-100 DISPLAY

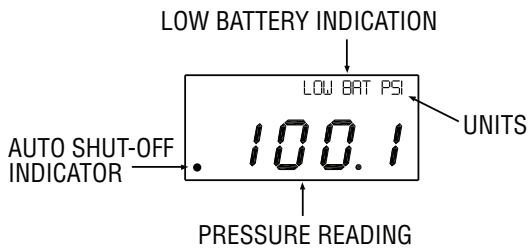

DPG Button Operation

Button	Operation	Action
	Turn Unit On	Press and hold ON button
	Turn Backlight On (Auto Shut-Off: 2 Min)	While gage is on press ON button
	Turn Backlight Off	While backlight is on press ON button
	Turn Unit Off	While gage is on, press and hold ON button 5 seconds for unit to turn off.
	Zero Gage	With no pressure applied to the gage, press and hold ZERO button until display flashes If gage will not zero, then gage is no longer meeting specified accuracy and should be sent back to the factory for recalibration Note: Gage is not to be zeroed while pressure is applied
	Unit Selection	Press UNIT button to change units on gage (Not all units are available for each range, please refer to model/range chart located below for available units)
	View Peak	Press P/V button to read peak (highest pressure) measurement
	View Valley	Press P/V button again to read valley (lowest pressure) measurement
	Reset Peak & Valley	Press and hold P/V button to reset peak and valley
	Exit Peak & Valley	Press ON button to exit peak/valley
plus	Disengage Auto Shut-Off	Auto shut-off will turn off an idle gage after 60 minutes. To disengage auto shut-off, press and hold ON button, then press and hold P/V button. A decimal will blink in the lower left hand corner of the display to indicate the auto-shut off is turned off. To turn on auto shut-off, repeat above procedure until decimal point stops blinking

Model/Range Chart

Model	Range psi	Pressure Ranges									
		kg/cm ²	bar	in Hg	ft wc	kPa	oz/in ²	in wc	mbar	cm wc	mm Hg
DPG-100*	-14.70-0	-1.033	-1.013	-29.93	-33.94	-101.4	-235.2	-407.3	-1013	-1034	-760.7
DPG-102	15.00	1.055	1.034	30.54	34.61	103.4	240	415.2	1034	1055	775.7
DPG-103	30.00	2.109	2.069	61.08	69.21	206.9	480	830.4	2069	2109	1551
DPG-104	50.00	3.515	3.448	101.8	115.4	344.8	800	1384	3448	3515	2586
DPG-105	100.0	7.03	6.895	203.6	230.7	689.5	1600	2768	6895	7031	5172
DPG-106	200.0	14.06	13.79	407.2	461.4	1379	3200	5536			
DPG-107	300.0	21.09	20.69	610.8	692.1	2069	4800	8304			
DPG-108	500.0	35.15	34.48	1018	1154	3448	8000				
DPG-109	1000	70.3	68.98	2036	2307	6895					
DPG-110	3000	210.9	206.9	6108	6921						
DPG-111*	5000	351.5	344.8								

Compound Ranges available: DPG-120* Range: 30" Hg-0-15 psi; DPG-121* Range: 30" Hg-0-30 psi; DPG-122* Range: 30" Hg-0-45 psi; DPG-123*: Range 30" Hg-0-60 psi; DPG-124*: 30" Hg-0-100 psi.

*Optional ceramic sensor available. Add "C" to the range (Ex. DPG-100C).